

22

WURLITZER®

CE

## *ONE MORE TIME CD*



**OPERATING INSTRUCTIONS  
FIELD SERVICE MANUAL**



**WARNING!** Although the beam emitted by the laser diodes is nearly invisible, it may cause severe damage to the human eye. Use an infrared indicator to check the laser beam.



**ATTENTION!**

The CD mechanism and many ICs are extremely susceptible to electrostatic discharges. The photo diodes and the laser diode are more sensitive to discharges than MOS ICs. Careless handling may immediately destroy components or can drastically reduce life expectancy of these components so that it will lead to failure after several weeks or even months of use.

Before you touch the player, discharge your hands and tools by touching a grounded metal part of the jukebox, such as the amplifier or the mechanism chassis. Make sure that you are connected via a wrist wrap with resistance to the same potential as the chassis of the jukebox. Keep parts and tools at the same potential.

If you remove the player in case of repair or for transport, short the harness with a short circuit plug.

When repairing, observe all valid safety rules. Do not change the original condition of the jukebox. Use original spare parts only.



This manual belongs to machines equipped with program versions 4.09 (or higher).

**Subject to alterations.**

<b>1</b>	<b>Unpacking</b> .....	<b>5</b>
1.1	Unlocking .....	5
1.2	Removal of mechanism shipping guards .....	5
1.3	Removal of motor book shipping guards .....	6
1.4	Power on.....	6
<b>2</b>	<b>Loading compact discs</b> .....	<b>7</b>
2.1	CD handling precautions - CD and player cleaning .....	7
2.2	Inserting CDs .....	8
2.3	Programming number of CDs in the carrier .....	9
<b>3</b>	<b>Coin operation or free play?</b> .....	<b>10</b>
3.1	Coin operation and coin return .....	10
3.2	Price settings .....	10
3.3	Examples .....	11
3.4	Color codes of coin input .....	11
3.5	Free play .....	12
3.6	Test credit.....	12
<b>4</b>	<b>Track selection</b> .....	<b>14</b>
4.1	How to select a track.....	14
4.2	The button R.....	14
4.3	The display flashes .....	14
4.4	I do not like this track - the button CANCEL.....	15
<b>5</b>	<b>Volume, sound and balance control</b> .....	<b>16</b>
5.1	Volume, sound and balance control - amplifier K99 .....	16
5.1.1	The infrared remote control .....	17
5.2	Volume, sound and balance control - amplifier F91.....	18
5.2.1	The infrared remote control .....	19
5.3	Pre-settings for volume.....	20
5.3.1	Pre-settings for bass and treble.....	20
<b>6</b>	<b>Programming short view</b> .....	<b>21</b>
<b>7</b>	<b>Jukebox programming</b> .....	<b>22</b>
7.1	Call up service programs .....	22
7.2	How to leave service programs .....	22
7.3	Programming of time functions .....	23
7.3.1	Clock setting, level 2 button 0 .....	23
7.3.2	Set date, level 2 button 1 .....	23
7.3.3	Set year and weekday, level 2 button 2 .....	23
7.4	Automatic random select (Playstimulator) .....	24
7.4.1	Programming start and stop time.....	25
7.5	Back Ground Music (BGM) .....	26
7.5.1	Number of BGM CDs and repeat time .....	27
7.5.2	Start position for BGM CDs and configuration .....	28
7.5.3	BGM time zones at different weekdays .....	28
7.6	HappyHour pricing (additional bonus plays) .....	30
7.6.1	Programming of the HappyHour start and stop time, level 2 button 6.....	30

7.6.2	Programming of the additional bonus plays, level 2 button 7 . . . . .	30
7.7	Number of tracks played successively on the same disc, level 2 button 3. . . . .	31
7.8	Album selection and memory reset by power off, level 2 button 9 . . . . .	32
7.9	Disabling single tracks . . . . .	33
<b>8</b>	<b>Data retrieval . . . . .</b>	<b>34</b>
8.1	Retrieval of least popular discs (flops), level 1 button 0 . . . . .	34
8.2	Top Tunes, level 1 button 1 . . . . .	34
8.3	Cash box contents, level 1 button 2 . . . . .	35
8.4	Total number of plays, level 1 button 3. . . . .	35
8.5	CLEAR ALL counters (reset to 0 0 0 0), level 1 button 3 + reset. . . . .	35
8.6	Memory of not playable CDs, level 1 button 6 . . . . .	35
<b>9</b>	<b>Amplifier K99 . . . . .</b>	<b>36</b>
9.1	Device description of the amplifier K99 . . . . .	36
9.2	Technical data . . . . .	36
9.3	Verification of power voltage . . . . .	37
9.4	Position of fuses and plug connectors . . . . .	38
9.5	The first power ON . . . . .	39
9.6	Volume control . . . . .	39
9.7	The infrared remote control . . . . .	40
9.8	Treble and bass control . . . . .	41
9.9	Automatic volume correction. . . . .	41
9.10	Background Music - volume attenuation . . . . .	41
9.11	External speaker connection . . . . .	42
9.12	External amplifier connection . . . . .	43
9.13	Disabling the internal mute circuit . . . . .	43
9.14	Input selector. . . . .	43
<b>10</b>	<b>Amplifier F91 . . . . .</b>	<b>44</b>
10.1	Verification of power voltage . . . . .	44
10.2	Position of fuses and plug connectors on the power amp board . . . . .	45
10.3	The first power ON . . . . .	46
10.4	Pre-settings for volume, bass, treble . . . . .	46
10.4.1	Pre-settings for volume . . . . .	47
10.4.2	Pre-settings for bass and treble . . . . .	47
10.5	Speaker connections . . . . .	48
10.5.1	The operating mode STEREO . . . . .	49
10.6	Connecting external speakers in operating mode 2-CHANNEL . . . . .	50
10.7	BGM mode - volume attenuation . . . . .	51
10.8	Automatic volume control (AVC) and clipping stage. . . . .	51
10.9	Overdrive protection. . . . .	51
10.10	Overload protection . . . . .	52
10.11	Tape input . . . . .	52
<b>11</b>	<b>70v output transformer (0043157) . . . . .</b>	<b>53</b>
11.1	Hints of connectable speaker loads . . . . .	53

11.2	Determination of the connectable speaker power .....	54
11.3	Hints for speaker connection .....	54
11.4	Connection of 70v systems .....	55
<b>12</b>	<b>Amplifier I84 .....</b>	<b>56</b>
12.1	Fuses .....	56
12.2	Volume control .....	57
12.3	Automatic loudness controller .....	57
12.4	Treble and bass control .....	57
12.5	Slide switch 'Stereo/2-Kanal' .....	57
12.6	Maximum amplifier load and external speakers .....	58
12.7	Connection of external speakers .....	58
12.8	Infrared remote control .....	59
12.9	Infrared remote control with selection buttons .....	60
<b>13</b>	<b>Function tests .....</b>	<b>61</b>
13.1	Digital display test / EPROM-version, level 1 button 4 .....	61
13.2	CD carrier control check, level 1, button 8 .....	61
13.3	Gripper arm motor test, level 1, button 7 .....	61
13.4	CD player check (START), level 1, button 6 .....	62
13.5	Jump to NEXT track, level 1, button 0 .....	62
13.6	Jump to PREVIOUS track, level 1, button 9 .....	62
13.7	STOP playing, level 1, button 5 .....	63
<b>14</b>	<b>Description of S&amp;CC price setting .....</b>	<b>64</b>
<b>15</b>	<b>Integrated test program of the CD-PRO player .....</b>	<b>65</b>
15.1	Access to the player functions without S&CC unit .....	65
15.2	Test functions CD-PRO .....	66
15.3	Special test functions of the CD-PRO player .....	67
<b>16</b>	<b>Functional description of the mechanism .....</b>	<b>68</b>
16.1	Abbreviations .....	68
16.2	Functional description .....	68
16.2.1	Power supply .....	68
16.2.2	S&CC supply .....	68
16.2.3	CD-PRO supply .....	68
16.2.4	Digital display .....	68
16.2.5	Number of plays and cash counter .....	69
16.2.6	Selection and CD carrier .....	69
16.2.7	Start / counting process .....	69
16.2.8	CD transfer .....	69
16.2.9	Mute off .....	69
16.2.10	Play .....	69
16.2.11	Cancel .....	69
16.2.12	CD return .....	70
16.2.13	New selection .....	70
<b>17</b>	<b>Error messages and remedy .....</b>	<b>70</b>
17.1	Failures with illumination, display and power system generally .....	71

17.2	Faults with the coin system .....	72
17.3	Faults by selection entry .....	73
17.4	Repetitive apply of selected or non-selected CDs to turntable .....	75
17.5	Failures in the system carrier - gripper arm .....	75
17.6	Failures with sound reproduction .....	77
17.7	CD not properly returned to carrier .....	77
<b>18</b>	<b>Accessories .....</b>	<b>78</b>
18.1	Microfone kit (part no. 0006953) .....	78
18.2	BGM-Connector .....	78
<b>19</b>	<b>Wiring and connection diagrams .....</b>	<b>79</b>
19.1	Wiring diagram door - illumination .....	79
19.2	Connection diagram OMT CD .....	80
19.3	Board layout Selection & Credit Computer .....	81
19.4	Wiring diagram Selection & Credit Computer .....	82
19.5	Board layout CDM12 SC .....	83
19.6	Wiring diagram CDM12 SC .....	84
19.7	Wiring diagram 24V distributor interface .....	85
19.8	Wiring diagram motor page system .....	86
19.9	Wiring diagram bubble tubes .....	87
19.10	Wiring diagram K99 - power supply .....	88
19.11	Wiring diagram K99 - output transformer .....	89
19.12	Wiring diagram K99 - pre-amplifier .....	90
19.13	Wiring diagram K99 - sound control .....	91
19.14	Wiring diagram K99 - port A .....	92
19.15	Wiring diagram K99 - Mute .....	93
19.16	Wiring diagram K99 - power supply Euro 230V .....	94
19.17	Wiring diagram K99 - power supply UL/USA 117V .....	95
<b>20</b>	<b>Declaration of Conformity .....</b>	<b>96</b>

# 1 Unpacking

## 1.1 Unlocking

The key is stored in the coin return cup in the RH cabinet wall. The key WUA 1 unlocks the cabinet by turning the key clockwise. The lock is spring loaded, press slightly against the door, this allows the key to turn easily. The two other keys with 5 digit number codes unlock the cash box at the bottom of the RH cabinet wall. In this box the hand transmitter is located if an infrared remote control has been installed.

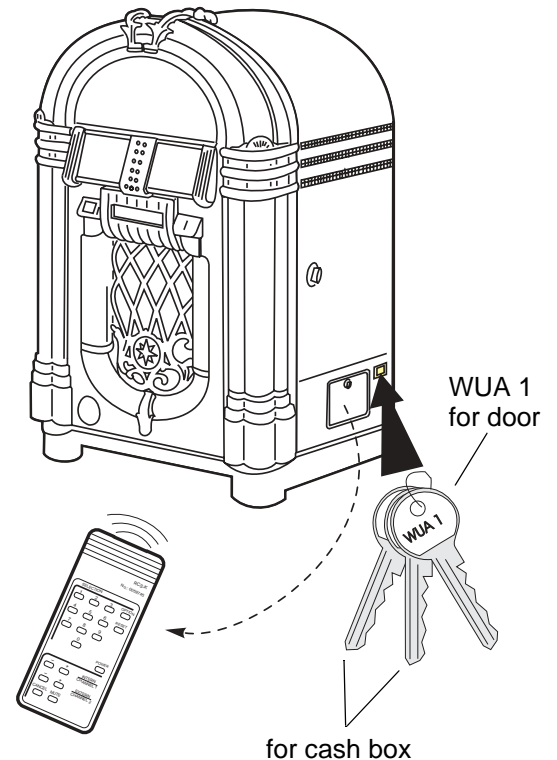

## 1.2 Removal of mechanism shipping guards

1. The mechanism platform is fixed to cabinet with one bolt in front LH side (1) and one bolt back RH side (1). Remove both completely using a 13mm spanner or a large screw driver. Possibly you can use the tool fixed to the lid of the gear box (2).
2. Remove plastic string at the pivot point of the pressure arm (3).
3. Remove plastic holder securing CD player chassis (4).
4. Remove foam (5), laser cover (6) securing laser head in CD player and instruction plate (7).
5. Remove foam between magnetic pressure disc and black plastic cover (8).

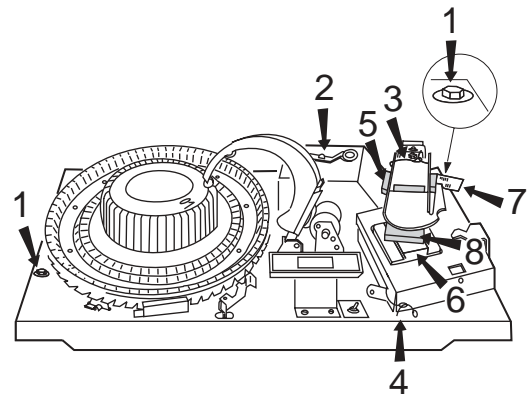

### 1.3 Removal of motor book shipping guards

Cut both plastic strings on both sides of the book (1).

Press push buttons (2) inside and turn down the book (3).

Remove elastic band from the motor book systems (4).



**NOTE:** Save the removed shipping guards. You may need them if you decide to move your machine to another location.

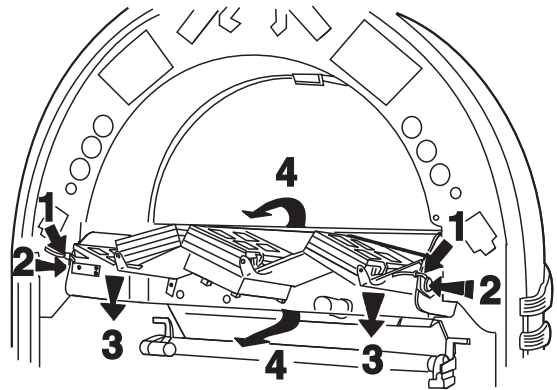

### 1.4 Power on



**NOTE:** Make sure that wall socket is grounded properly.

The CD-jukebox operates on normal household power outlet. Set mains switch at rear wall of cabinet to on position. If the selection and credit memory is empty the basket turns once and the left two digits show alternately a "0". After a short time the display counts up to the carrier size in the two RH digits (50 or 00 for 100 discs). After this the basket stops in position "01". The digital display shows "0 0 0 0", then "0 0 0 1" when a basket with 100 CDs is used "0 1 0 1" for a 50 CD carrier.

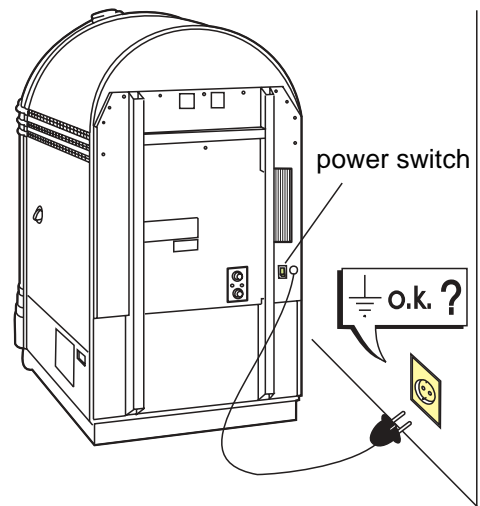



## 2 Loading compact discs

### 2.1 CD handling precautions - CD and player cleaning

Dust, fingerprints or other dirt on the disc surface can cause skipping, jumping or sticking problems.

Because of this never touch the surface of a disc! However it is rather easy to remove nicotine, dust or fingerprints.

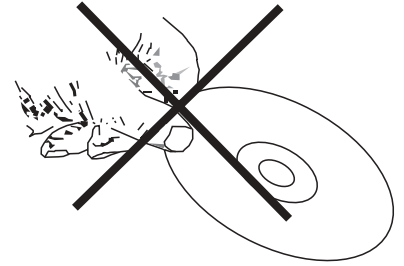

#### Nicotine, dust, fingerprints:

Dust can be removed with a lintfree soft cloth. If necessary, remove heavy dirt or fingerprints with a moistened soft cloth soaked in a solution of water and a detergent. Never use record cleaning sprays or anti static sprays! Furthermore, do not use other types of cleaners containing benzene, thinner or other solvents. These liquids will cause damage to the surface of discs. Move the cloth from the inside towards the outside and not in circular motion.

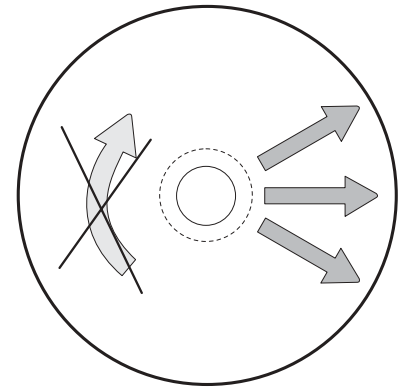

#### Removing scratches:

Use a soft cloth and a soft polish.

#### Laser lens cleaning:

Smoke and dust soils the lens. It can be cleaned with a cue-tip soaked in a detergent (i.e. Kodak Lens Cleaner, part no. 0051735). Place the tip on the lens and press down carefully.

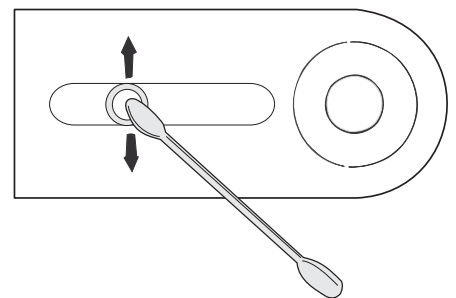

**ATTENTION!** The whole laser unit is very sensitive!

- Move the cue-tip only in the direction shown in the picture (perp. to the sledge direction).
- Do not scratch the special treated surface of the lense.
- Take care that the cleaning solution will not run into the focus unit.
- Keep away metal parts from the lens unit. A strong magnet is located underneath the lens. It attracts also smallest metal parts and so can block the complete unit.

## 2.2 Inserting CDs

Insert up to 50 or 100 CDs, depending on the compartments in the carrier. Start with 01. The "Label" must show always to the left, towards the next lower number. To achieve the optimum position for loading, press in steps the lever "rotate carrier". If less than 50 (100) discs are used, the number of discs used has to be programmed in the service program level 1, button 5 (see chapter "Programming number of CDs in the carrier", see page 9).



**ATTENTION!** For carriers with 100 CDs the position '00' is the 100th CD.

It is recommended to insert the Compact Disc and then the title page into the appropriate numerical slot position of the motor page system. The pages can be turned manually by hand without any damage to the motor drive. In some models the transparent dust cover of the record carrier has to be lifted up at the front, it will rest in this position.



**NOTE:** After unpacking or if you turned the pages manually sometimes it seems that the motorbook does not turn properly. In this case turn the whole motorbook once forward and backward using the buttons.

It is necessary to reprogramme the number of CDs in the carrier if a number less than 50 or 100 discs are inserted to avoid the changer mechanism operating with empty compartments.

If the number of CDs is programmed correctly the display will flash when you select an empty compartment. A flashing display always indicates a wrong selection or not enough credit.

The number of CDs in the carrier has to be programmed in service level 1, selection button 5, described as follows.

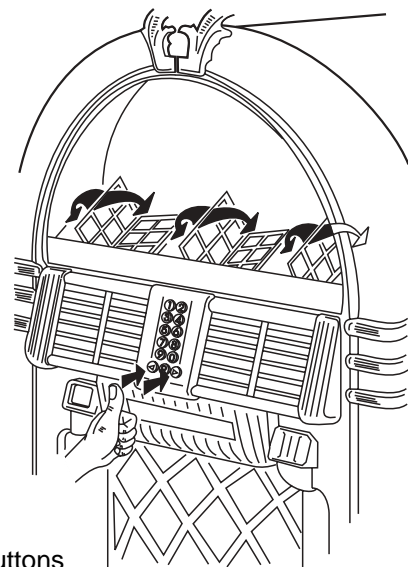
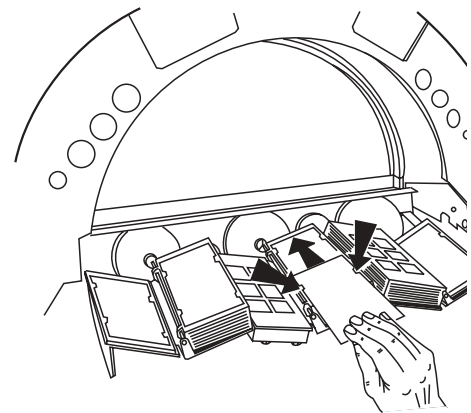
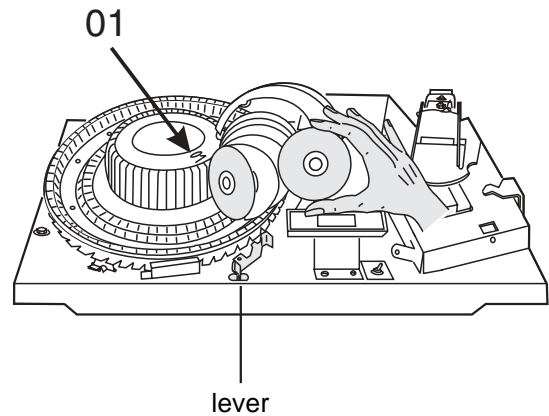

buttons to turn the motor book

### 2.3 Programming number of CDs in the carrier

At the rear wall inside the jukebox cabinet the Selection & Credit Computer is situated. Some units are equipped with a metal cover. In this case the slide switch "SERVICE" and the button "LT" are accessible through holes.

To programme the number of inserted CDs (service program, level 1):

1. Set the slide switch 'service' at the SCC-unit to ON.
2. Press 'LT' button.
3. Press selection button 5 -hold down- and press selection button R than release both buttons.
4. Enter the number of inserted CDs (without BGM CDs) with two digits followed by 00, example: 50 for 50 discs (exception: 100. CDs = 00).

To check the new settings, press selection button 5 again.

#### Exit the service program:

1. Set the slide switch 'service' at the SCC unit to OFF.
  2. Press 'LT' button.
- The changer starts an initialisation run. After this the jukebox is ready to operate.

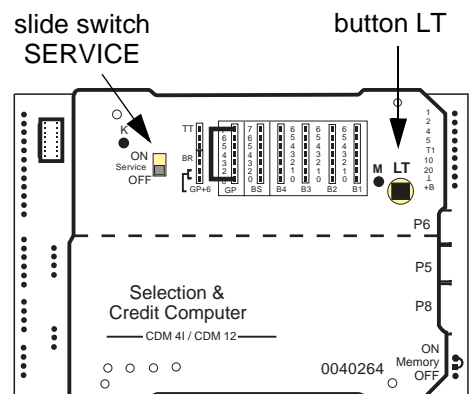
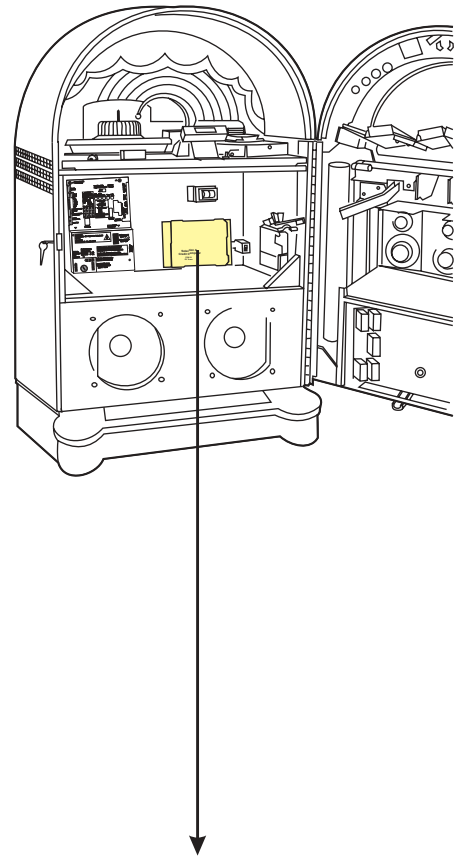

### 3 Coin operation or free play?

Both coin operation or free play are adjustable at the "Selection & Credit Computer" unit. It is located at the rear wall inside the cabinet underneath the CD-player. Special jumpers (short wires, located in the accessory pack of the manual ) are used to be set on the SCC-unit. As long as no jumper is set in row GP from 0 to F (free play) the jukebox works with coins only.

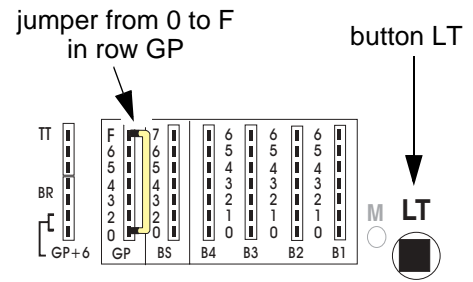

#### 3.1 Coin operation and coin return

From factory the jukebox is set to coin operation. If you insert a certain number of coins according to the denomination label, the jukebox gives the credits or plays it is adjusted for.

You will get your change by turning the rotary switch at the RH side of the jukebox.

If you want to change the play prices you have to change the jumper settings on the SCC-unit. See examples in the accessory pack.

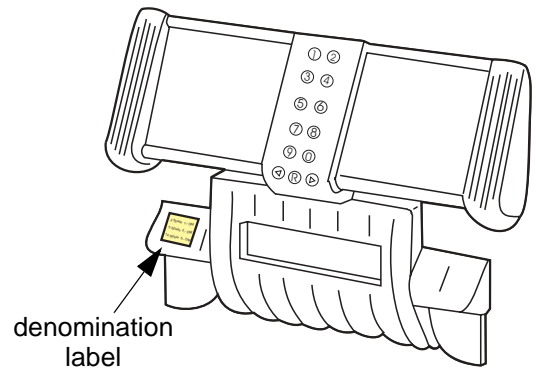

#### 3.2 Price settings

In the 'EURO' version no play prices are pre-set. Usually the prices are preset by the factory according to the denomination label in the accessories. If other combinations are required, refer to the following examples. For price setting proceed as follows:

1. Switch on the jukebox.
2. Coin output plugs (1) should be set according an separate attached instruction by connecting to the pin row (2) on the SCC unit. Pay attention to wiring colors (refer to [chapt. 3.4 on page 11](#)).
3. Set the attached jumpers in B1 to B4 according to the number of the desired additional bonus plays. (3).
4. Press „LT“ button once (4) to accept the new price/bonus setting.

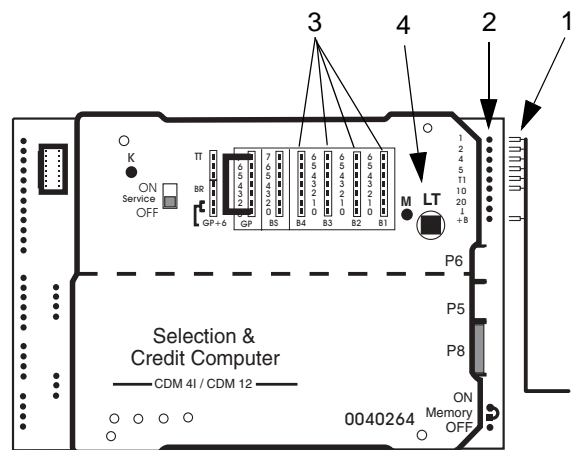

### 3.3 Examples

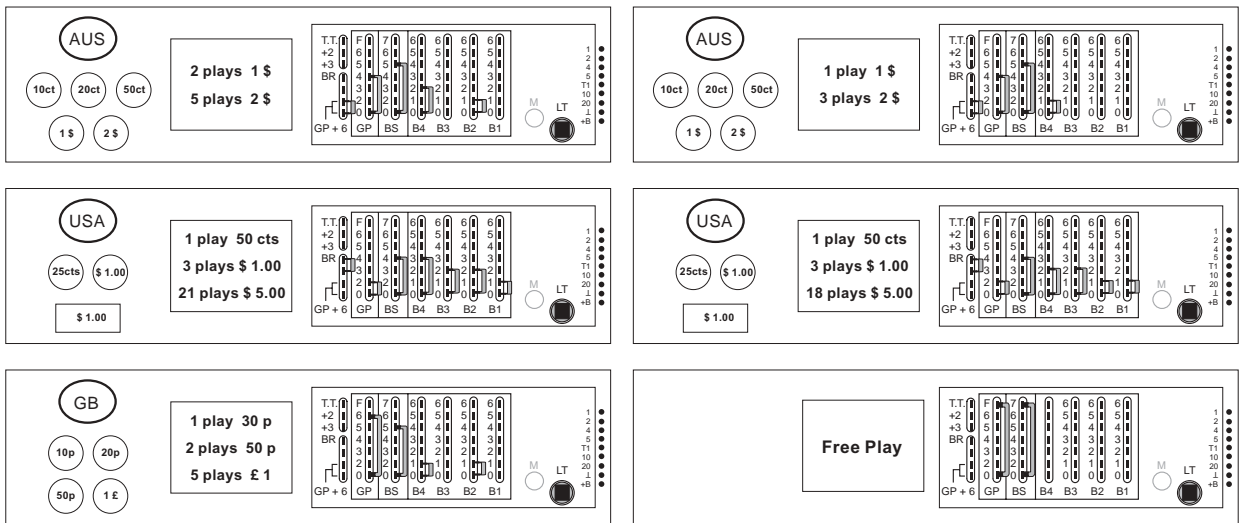

### 3.4 Color codes of coin input

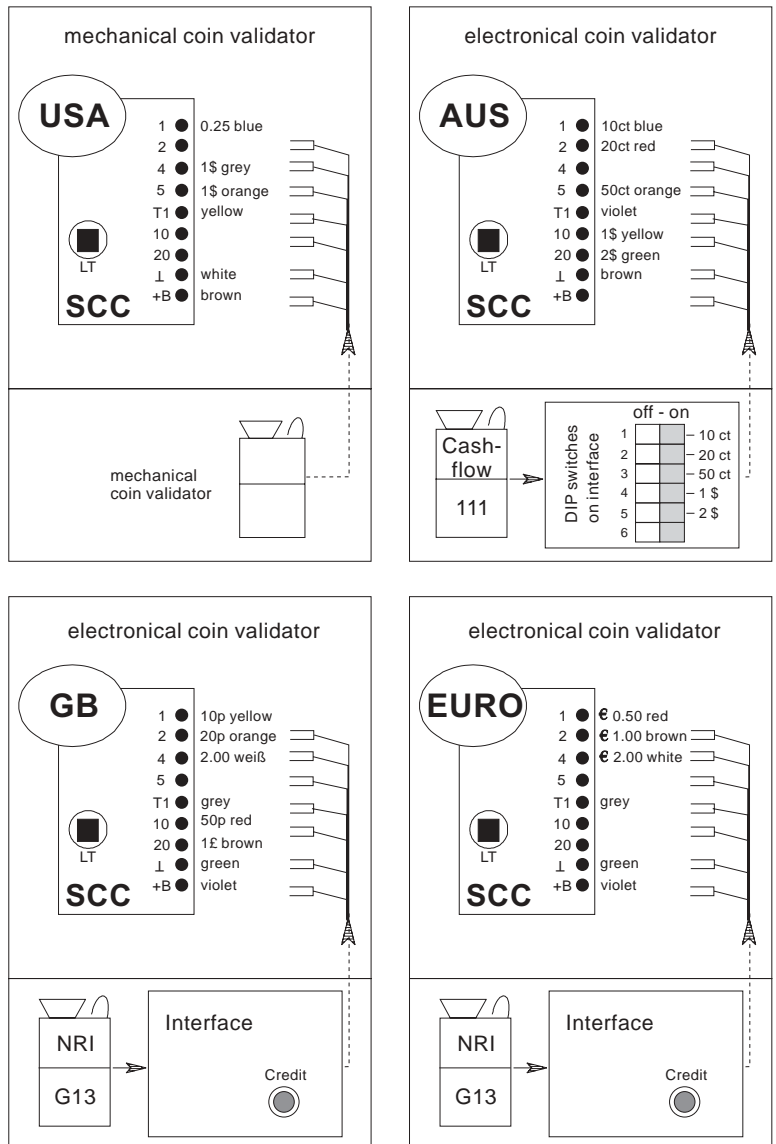

### 3.5 Free play

To set the jukebox to free play:

1. In case there are already jumpers in the rows GP and BS, notice their position (for later resetting to coin operation) and remove them.
2. Set a jumper from 0 to F (free play) in the row GP on the SCC unit.
3. Press 'LT' button.
4. Now one track is selectable without coin insertion.
5. In between two to six plays are selectable by setting an additional jumper in the row 'BS' (Bonus Step) from 0 to 2 or from 0 to 6.
6. Up to 47 tracks are pre-selectable by setting a jumper in the row 'BS' from 0 to 7.

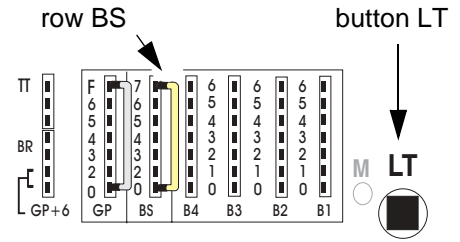

### 3.6 Test credit

For repair and test purposes it is possible to give test credits. By touching the test credit button you get one credit also shown in the digital display. You can terminate un-used credits by pressing the LT button.

In jukeboxes with an electrical coin validator you can find the test credit button on the coin validator interface board.

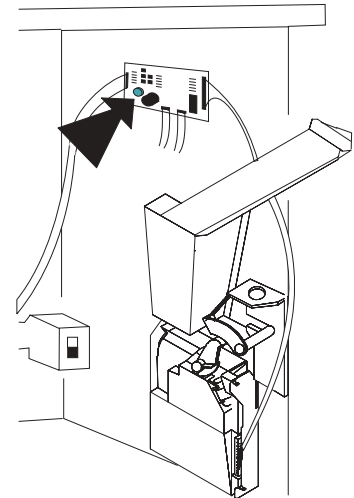

In jukeboxes with mechanical coin validator the test credit button is mounted over the return lever inside.

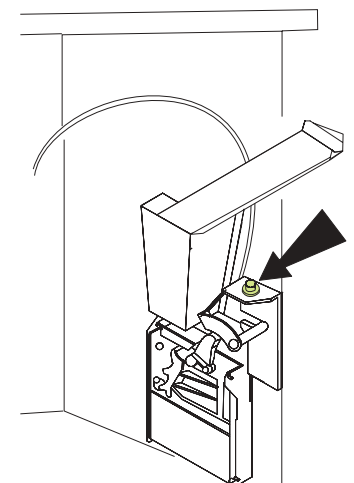

Price settings:

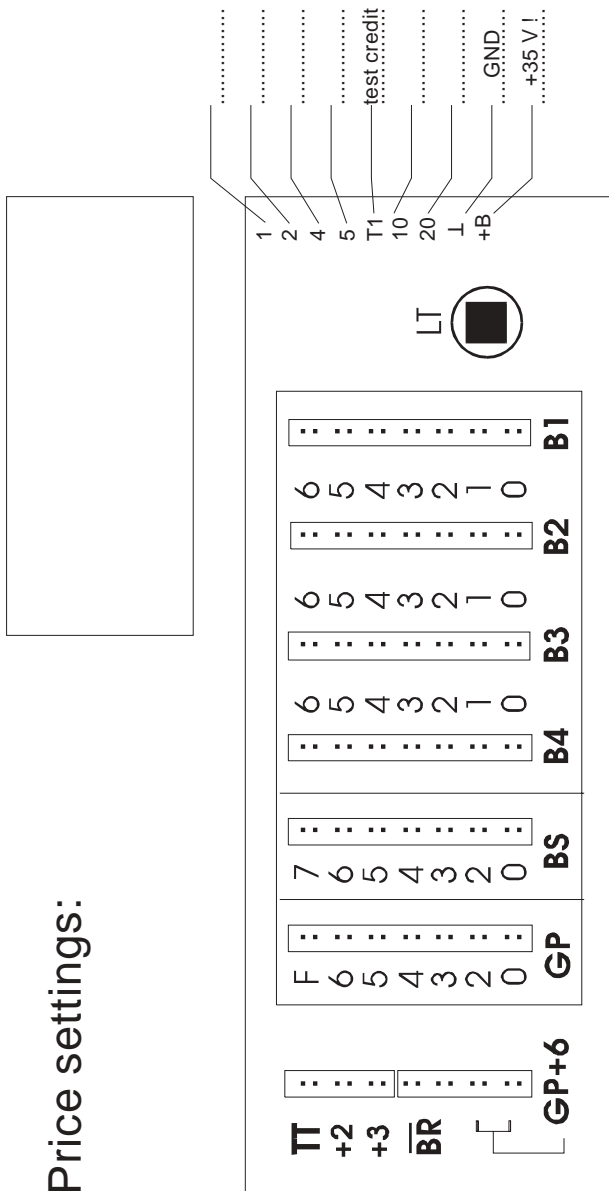

	1.	2.	3.	4.	5.	6.	7.	8.	9.	10.	11.	12.	13.	14.	15.	16.	17.	18.	19.	20.	21.	22.	23.	24.	25.
pulse																									
inserted money																									
plays from GP:																									
from bonus step																									
plays B1...B4																									
total plays																									

## 4 Track selection

### 4.1 How to select a track

If credit exists or free play is set you can select tracks by means of the buttons 0 - 9 on the keyboard. First enter the number of the CD with two digits, then the track with two digits too. Example: CD 2, track 9: Enter 0 - 2 - 0 - 9 (Exception: CD 100 = 00.)

### 4.2 The button R

You can delete wrongly entered numbers up to the third digit by means of the button R (Reset). But after having entered the fourth digit the jukebox stores and executes a selection. By pressing the button R the available credit will be displayed for a few seconds.

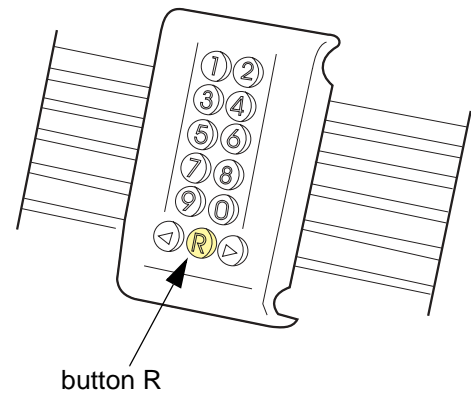

### 4.3 The display flashes

After entering the fourth digit of a selection the jukebox starts to search and play the selected CD immediately. If the display flashes the entered selection was not valid. Check:

- if credit is available or
- if the selection is higher than the programmed number of CDs in the carrier



If you select a higher track number than available on a CD the jukebox overcounts the tracks and starts at the beginning.

Example: CD 03 contains 17 tracks. But selected track is 0 - 3 - 1 - 9. The jukebox plays track 02 of CD 03.

**A maximum of 25 tracks per CD can be selected!**



#### 4.4 I do not like this track - the button CANCEL

If you do not like a track you can cancel it by pressing the button 'CANCEL' at the rear side of the jukebox or at the remote control. The jukebox stops playing or plays the next track if a selection has already been made.

You can terminate all selections only by pressing the button LT on the SCC unit .

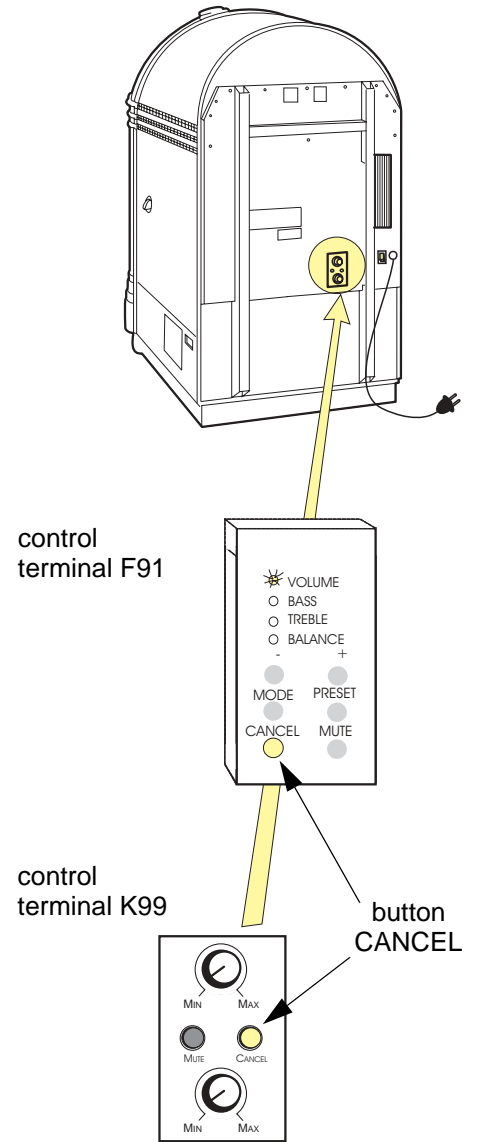

## 5 Volume, sound and balance control

### 5.1 Volume, sound and balance control - amplifier K99

#### Volume control

You can control the volume of the jukebox from different points at the same time:

1. With the pots Vol.1 and Vol.2 on the amplifier.
2. With an optional connectable IR remote control.
3. With the pots of the control box at the rear side of the jukebox.

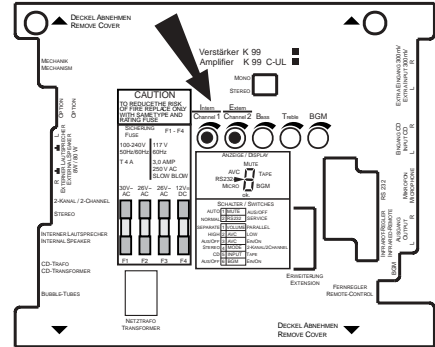

The device from which the volume is altered last determines it.

The volume control unit can be taken out and may be mounted at another place as a remote control. Its cable may be extended as required with any kind of wire. The voltages of the control wires are 5V DC.

The control box has two volume knobs (Intern / Channel 1 and Extern / Channel 2). In position "Stereo" the knob "Intern / Channel 1" is effective for the internal speakers. The knob Extern / Channel 2 is controlling the volume of the RCA outputs for an optional external amplifier. In position "2 Channel" of the DIP switch the channels 1 (RH) and 2 (LH) are controllable separately.

**The pots Vol. 1 and Vol. 2 on the amplifier are not effective if the wire control box is connected**

### 5.1.1 The infrared remote control

As desired an infrared remote control will be installed from factory or can be delivered as conversion kit (part no. 0058809). If it has been installed the hand transmitter is located in the cashbox.

If credit is given or free play is programmed a CD can be selected with the buttons 0 to 9 and R.

Double button functions as required in the service programs (i.e. press button 5 -hold down- and press button R), are impossible. For this you only can use the keyboard of the jukebox.

You can control the volume by means of the buttons + and -. In stereo mode the internal +/- buttons control the volume of the internal speakers. The external +/- buttons control the volume of the K99 RCA jacks for an optional external amplifier. In 2-channel mode you can control the external speakers by the buttons + and - of the external channel.

Beam the jukebox directly if possible.

You can connect the wire remote control box as well.

The power-on volume level is always set by the channel 1 and 2 pots on the amplifier or on the control box (if connected).

Batteries will be delivered. To open the battery compartment move the cover like shown in the picture.

Needed battery type and position of the batteries in the hand transmitter are shown on the casing.

Part no. of the hand transmitter: 0059745.

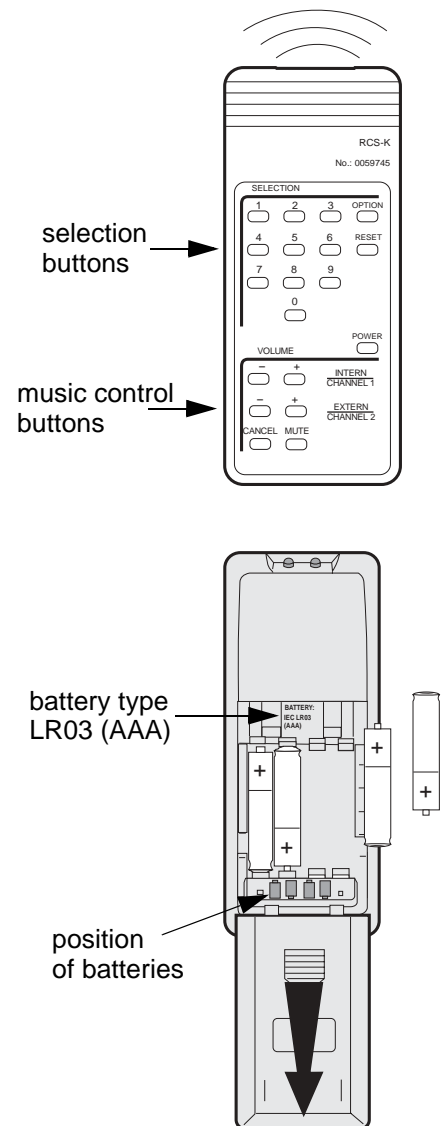

## 5.2 Volume, sound and balance control - amplifier F91

### The control terminal at the rear

With the control terminal at the rear side of the jukebox the volume, treble, bass and balance can be controlled individually.

After power up or if no button has been pressed for approx. 5 sec or after the button PRESET has been pressed, the terminal stays in the mode "VOLUME". The LED "VOLUME" lights. In this mode you can control the volume by means of the buttons '+' and '-'.

One LED corresponds to each mode. All modes are accessible by pressing the 'mode' button. With the buttons '+' and '-' treble, bass or balance can be controlled.

The control terminal can be taken out and be used as a wired remote control.



**ATTENTION!** Depending on adjusted volume of the jukebox noise levels of more than 70 dB can be reached.

### The meanings of the buttons...

- **MODE:** Switches to the next operating mode. After about 5 seconds without operating any buttons, 'volume' mode is resumed.
- **PRESET:** Volume, bass, treble, and balance are set to the pre-set according to DIP switch setting. Actual mode is set to 'Volume'.
- **CANCEL:** Rejects a playing track. If album play is selected the next track will be played.
- **MUTE:** As long as this button is activated, the amplifier output is muted.

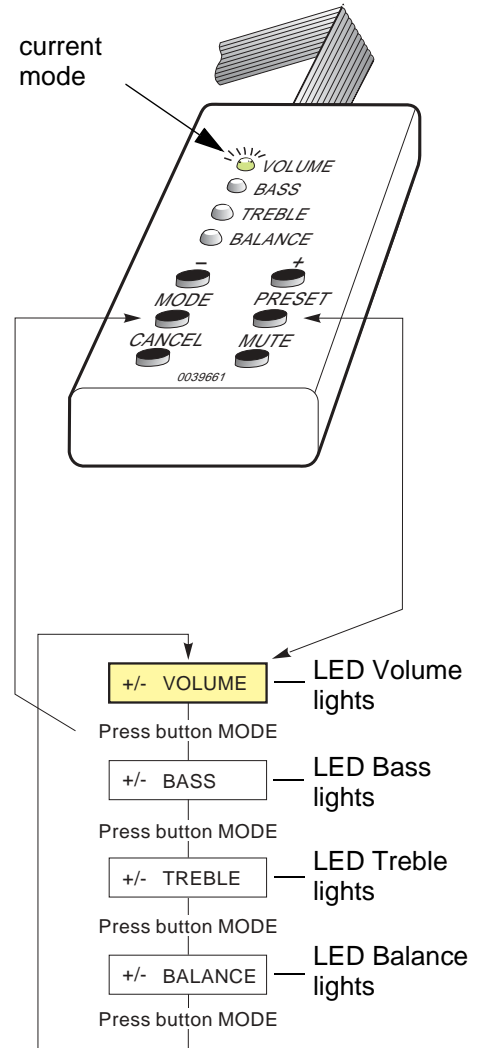

### 5.2.1 The infrared remote control

As desired an infrared remote control will be installed from factory or can be delivered as conversion kit (part no. 0040435). If it has been installed the hand transmitter is located in the cashbox.

If credit is given or free play is programmed a CD can be selected with the buttons 0 to 9 and R.

Double button functions as required in the service programs (i.e. press button 5 -hold down- and press button R), are impossible. For this you can use the keyboard of the jukebox only.

The meanings of the music control buttons are according to the buttons on the control terminal on the rear side of the jukebox (ref. to the prev. chapter).

The receiver eye of the infrared remote control is located behind the hole between the design elements on top of the front door. Beam this point directly if possible.

The common control terminal can be connected besides. It can be mounted outside to display the actual mode.

Batteries will be delivered. To open the battery compartment move the cover as shown in the picture.

The required battery type and position of the batteries in the hand transmitter are shown on the casing.

Part no. of the hand transmitter: 0040443.

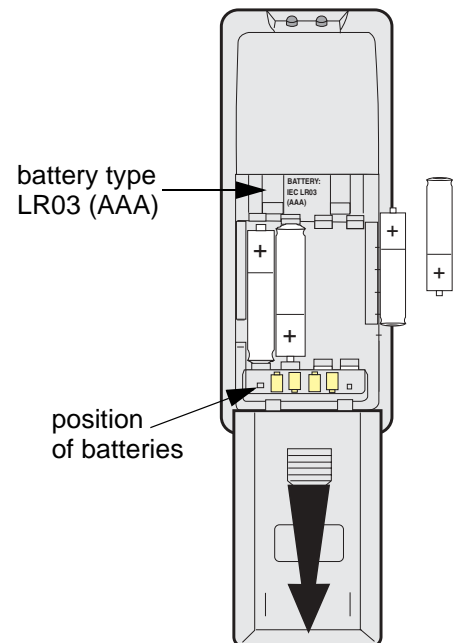
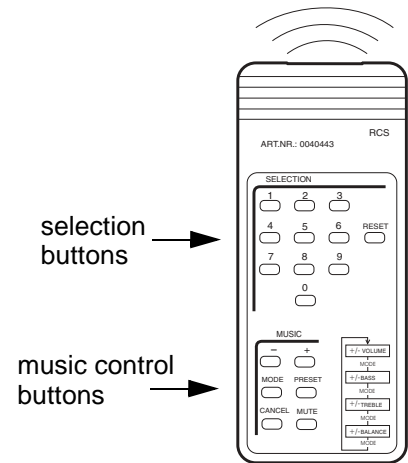

### 5.3 Pre-settings for volume

After power on of the jukebox or after pressing the button 'preset' the values of volume, bass and treble reach the values set by the DIP switches.

You can set the basic values for volume in 63 steps from zero up to maximum volume.

At the amplifier front side, opening "Volume", there are 6 DIP-switches for each channel. These switches have different values (1, 2 ... to 32). If you add all the values of the switches in position "ON" you will get the value for the set volume.

Consequently the switches 32 and 16 give a coarse adjustment whilst the lower numbers may be used for fine adjustment.

You can find the recommended settings on the amplifier cover.

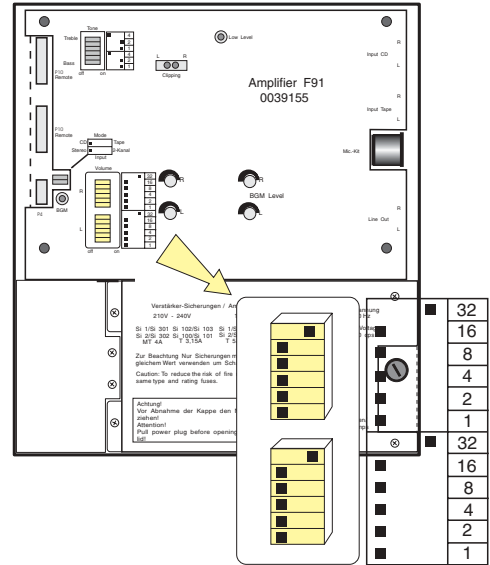

**NOTE:** If all switches are in position OFF no volume, if all switches are in position ON, the maximum volume appears at power on !

#### 5.3.1 Pre-settings for bass and treble

Similarly the values for bass and treble can be set. Both channels should be adjusted the same.

Three DIP-switches with the values 1, 2, 4 are provided for each bass and treble. You can choose 7 different steps from minimum to maximum. Adding all switches set to "ON" gets the set value.

The recommended factory settings are printed on the amplifier cover.

**If you change the DIP-switch settings while the jukebox operates remember that the new settings will only take effect after having pressed the button 'PRESET' at the control terminal.**

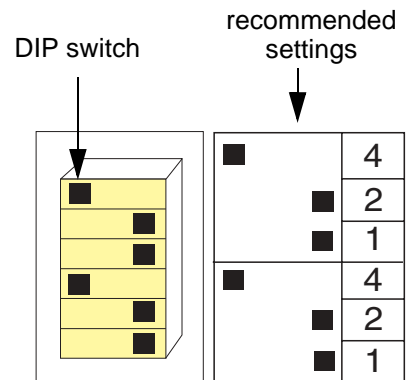

# 6 Programming short view

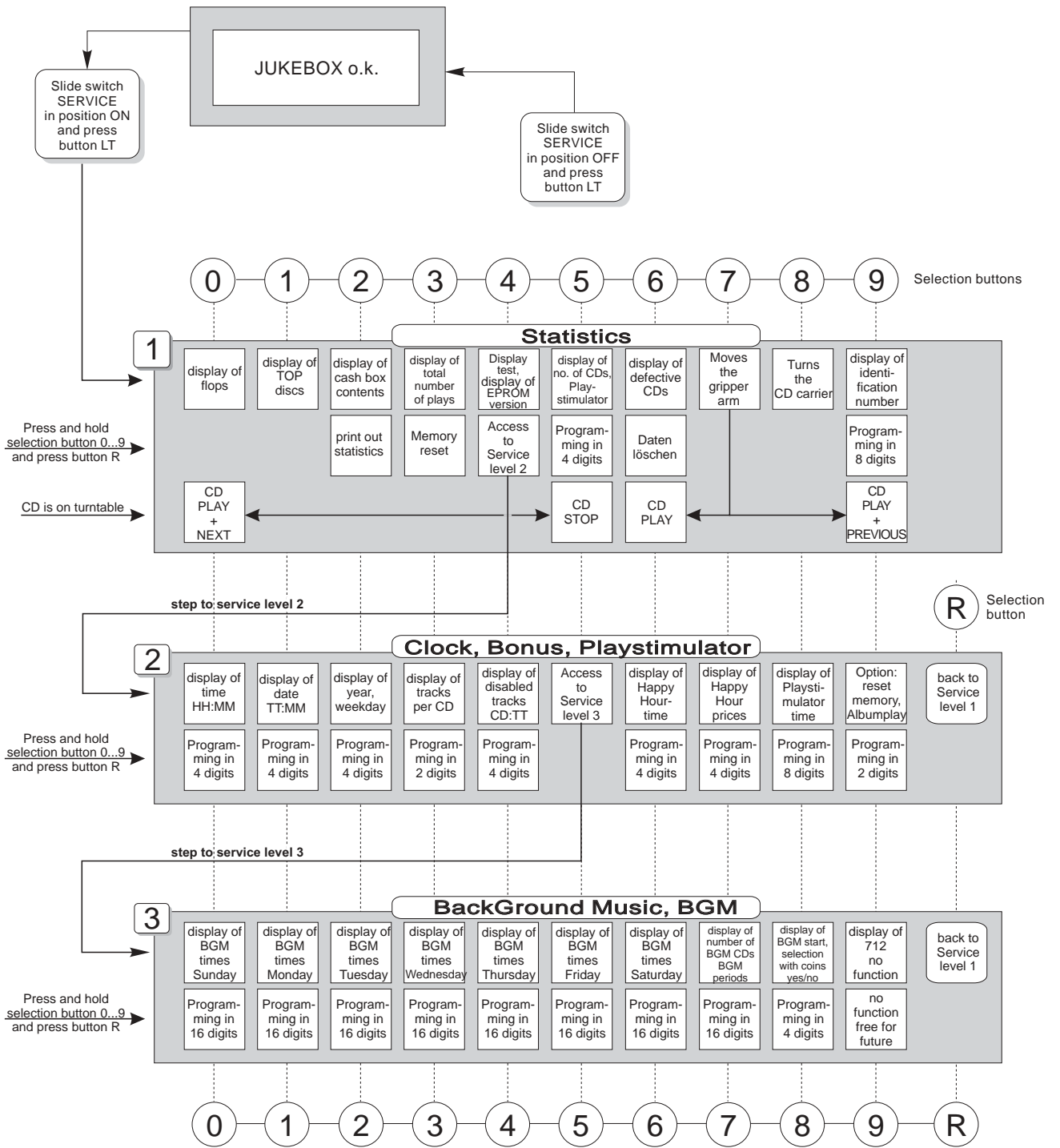

OPERATING INSTRUCTIONS

## 7 Jukebox programming

Additional features like Playstimulator, BGM time and Happy Hour time are programmable. These features are programmable in the service mode of the SCC unit.

### 7.1 Call up service programs



**NOTE:** To keep the data stored when power is off the plug “Memory” must be set to “ON” position on the SCC unit, otherwise all programmed data in service levels are reset when power is interrupted.

#### Call up service programs:

1. Set slide switch “Service” from position OFF to ON, then press the LT button. Service level 1 is reached, display shows '0 0'.
2. Press button 4 - hold it - and press button R, display is dark, service level 2 is reached.
3. Press button 5, display is dark, service level 3 is reached.



**NOTE:** If button R is pressed first in service levels 2 or 3, the S&CC will jump back to service level 1 automatically.

### 7.2 How to leave service programs

1. Set the slide switch SERVICE in position off.
2. Press button LT.
- The changer starts an initialisation run. After this the jukebox is ready to operate.

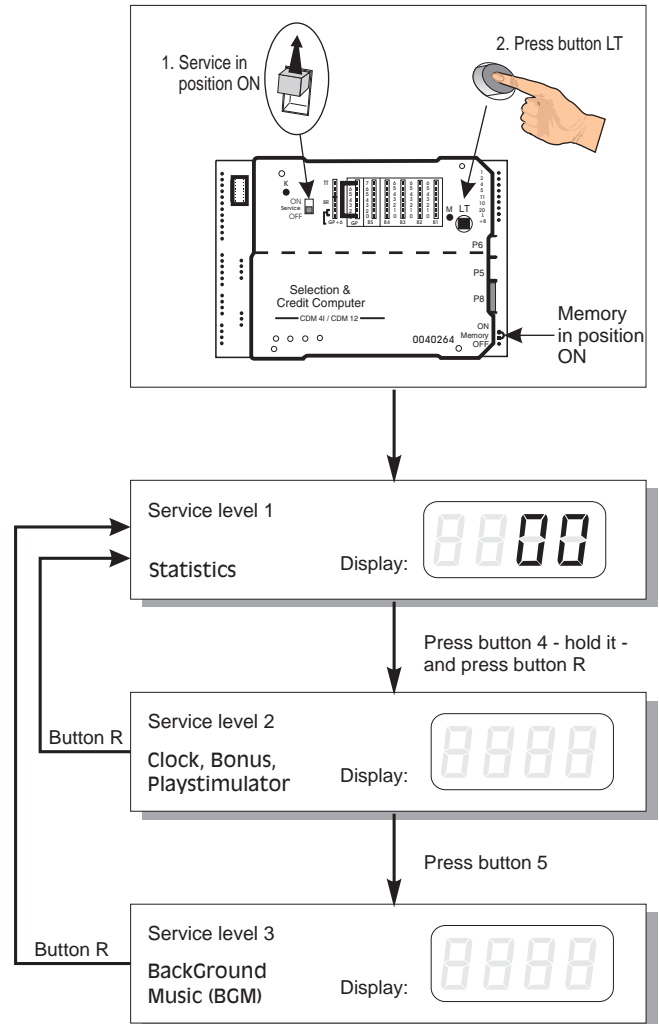



## 7.3 Programming of time functions

### Service level 2

It is necessary to program the time, date and weekday once or at least to control these settings. Only then the jukebox can switch on and off the playstimulator or the Back Ground Music at the desired time. It is useful to program time, date and weekday in a single pass.

To program the time (and also the date):

1. Set the slide switch 'service' at the SCC-unit to ON.
2. Press 'LT' button.
3. Press selection button 4 -hold down- and press selection button R than release both buttons.
4. Service level 2 is reached.

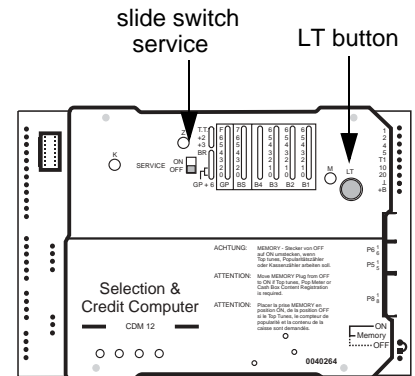

### 7.3.1 Clock setting, level 2 button 0

5. Press selection button 0. The display shows the current time. If the displayed time is not correct:
6. Press selection button 0 -hold down- and press selection button R. Release both buttons.
7. Enter the correct time with four digits.

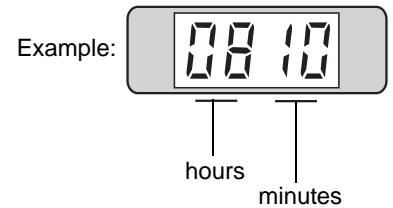

### 7.3.2 Set date, level 2 button 1

8. Press selection button 1. The display shows the current date. If the displayed date is not correct:
9. Press selection button 1 -hold down- and press selection button R. Release both buttons.
10. Enter the correct date with four digits.

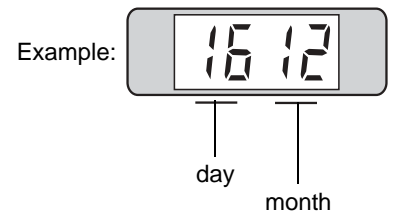

### 7.3.3 Set year and weekday, level 2 button 2

11. To display the year and the weekday press selection button 2:  
The weekdays are assigned to numbers as shown.  
0 = Sunday                      4 = Thursday  
1 = Monday                      5 = Friday  
2 = Tuesday                      6 = Saturday  
3 = Wednesday

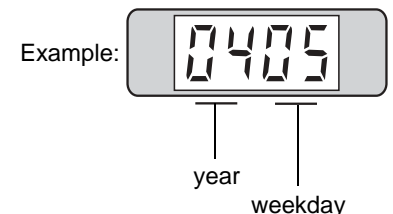

12. To program press selection button 2 -hold down- and press selection button R. Release both buttons.
13. Enter the correct year with two digits, then enter a 0 followed by the number of the weekday.

**Exit the service program:**

1. Set the slide switch 'service' at the SCC unit to OFF.
  2. Press 'LT' button.
- The changer starts an initialisation run. After this the jukebox is ready to use.

**7.4 Automatic random select (Playstimulator)**

If the Playstimulator is programmed the jukebox plays random tracks of the CDs in carrier registered in the service program level 1, button 5. CDs declared as BGM CDs (ref. to the next chapter) will not be used! The time between the last track played by inserted money and the first random track of the Playstimulator is programmable from 1 up to 98 min. This time is also the repeat time between two random plays. The volume is the same as in normal operation. The Playstimulator will be interrupted immediately when a selection is made and restarts after having played the selected track(s).

By means of an optional switch you can also switch the box to CONTINUOUS PLAY MODE without any need to enter the service program. Part number of this switch is 0034410. It has to be connected to P8 of the SCC unit. (This switch is standard for all One More Time CD).

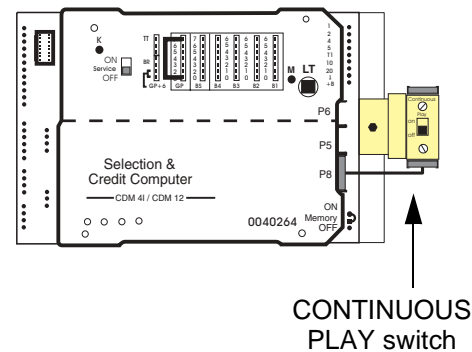
**The Playstimulator only works:**

- if Back Ground Music is not activated at the same time
- if time is programmed correctly
- if no credit left

**Repeat time programming**

To programme the repeat time for the Playstimulator (service program level 1):

1. Set the slide switch 'service' at the SCC-unit to ON.
2. Press 'LT' button.
3. Make sure that all time details are programmed properly otherwise you have to reprogramme (see chapter 'The internal clock')
4. Press selection button 5. Display shows four digits.
5. Both LH digits show the number of CDs in the carrier, this number has to be identical with the real number. Both RH digits show whether Playstimulator is enabled (01-99) or disabled (00). The numbers 01 up to 98 show repeat time between two random tracks in minutes, 99 means continuous play without any break.

A = number of CDs in the carrier (00 = 100)

B = repeat time programmed to 10 minutes

Example:

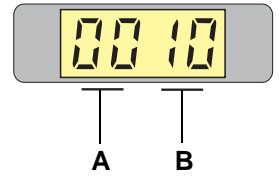

A = 50 CDs in carrier

B = no random plays

Example:

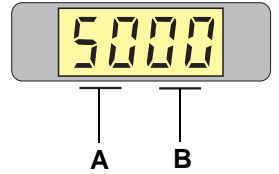

A = 63 CDs in carrier

B = Playstimulator on, continuousplay

Example:

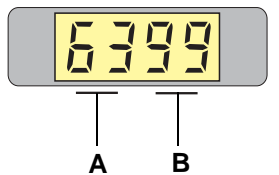

6. Note the number of CDs in carrier.

7. Press selection button 5 -hold it- and press selection button R. Display goes dark. Enter the noted number of CDs in carrier and Playstimulator interval time (or '00' for Playstimulator OFF or '99' for continuous play) with four digits.

#### 7.4.1 Programming start and stop time

If start and stop time is programmed the jukebox only plays random tracks in this time period.

**You can not programme the Playstimulator over 24.00 o'clock (e.g. 23.00 to 2.00 o'clock) !**

Call up service program 2 by pressing the slide switch on SCC unit to position ON, press button LT, then press button 4 -hold it- and press selection button R. Then

press selection button 8. The display shows at first a flashing '1'. This means 'start time'.

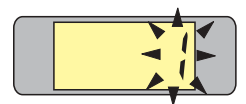

Then the time will be displayed, here 14.05 o'clock (2.05 p.m.).



Press selection button 8 once again. Now the display shows a flashing '2'. This means 'stop time'.

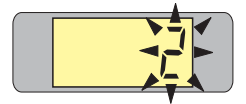

Then the time will be displayed, here 18.30 o'clock (6.30 p.m.).

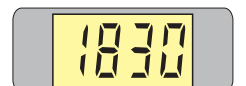

To reprogramme press selection button 8 - hold - and press selection button R. Release both buttons. The digital display goes dark. Enter the start and stop time with eight digits.

**Example:** The jukebox should play random tracks from 09.00 in the morning to 17.00 in the afternoon..

Enter:     0 - 9 - 0 - 0 - 1 - 7 - 0 - 0  
           start time     stop time

To check the start time: press selection button 8. To check the stop time: press selection button 8 again.

If the Playstimulator does not work. Check if:

- the clock is set correctly ?
- start and stop time is programmed?
- repeat time is set correctly (not 0)?
- BGM play mode is disabled (ref. to next chapter).
- credits are still in memory. Display the remaining credits by pressing button R. If so, delete with button LT.

**Exit the service program:**

1. Set the slide switch 'service' at the SCC unit to OFF.
  2. Press 'LT' button.
- The changer starts an initialisation run. After this the jukebox is ready to operate.

**7.5 Back Ground Music (BGM)**

If BGM is programmed and activated a random track from the CDs declared for BGM will be played. The time between the last selected played track and the first BGM track is programmable between 1 and 98 minutes. This time is also the repeat time between two BGM tracks.

For the **K99** amplifier the reproduction loudness will be reduced by a certain factor in the BGM (Back Ground Music) mode.

You also can switch "BGM" on by means of the DIP switch "BGM" for test purposes. The RH bottom segment of the status display on the amplifier indicates "BGM active". You can adjust the volume attenuation with the pot "BGM", as long it is active.

**amplifier K99**

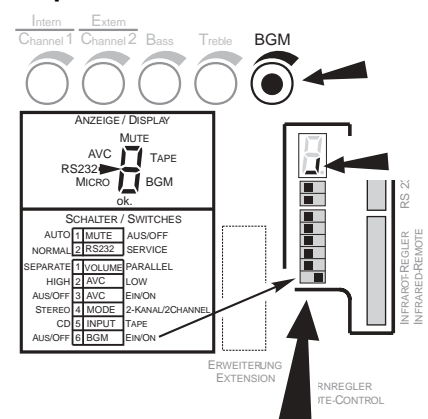

**F91:** The volume for BGM reproduction is reduced compared to the normal volume. It is adjustable with the two BGM pots (RH channel / LH channel) on the amplifier. BGM mode is active when the LED on the amplifiers lights. The source of the BGM control signal is the SCC unit plug brown (X6), pin 1. Once the BGM mode is activated, it is not possible to operate the Playstimulator.

If a selection is made by means of coin insertion the track being played will be interrupted immediately. Two intervals can be programmed for each weekday.

**amplifier F91**

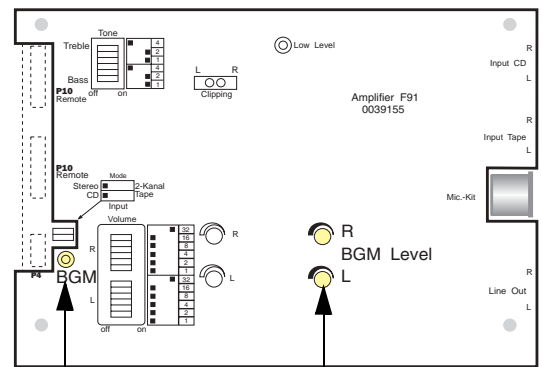

BGM light emitting diode (yellow), indicates whether BGM is active

BGM trim pots

**To enable BGM (service program, level 3) :**

1. Set the slide switch 'service' at the SCC-unit to ON.
2. Press 'LT' button.
3. Press selection button 4 -hold down- and press selection button R then release both buttons.
4. Press selection button 5. Service level 3 is reached. The display is dark. At this level all BGM options can be checked and/or programmed.

For the K99 amplifier the reproduction loudness will be reduced by a certain factor in the BGM (Back Ground Music) mode.

You also can switch "BGM" on by means of the DIP switch "BGM" for test purposes. The RH bottom segment of the status display on the amplifier indicates "BGM active". You can adjust the volume at-tenuation with the pot "BGM", as long it is active.

**7.5.1 Number of BGM CDs and repeat time**

Press selection button 7, the display shows e.g.:

A = number of BGM CDs; disabled for Playstimulator  
BGM OFF = 00.

B = Repeat time between the single BGM tracks (10 min.)  
BGM-continuous play = 00

**To programme** press selection button 7 -hold down- and press selection button R. Release both buttons. The display goes dark. Enter the number of CDs and the repeat time with 4 digits.

Example:  
5 CDs reserved for BGM,  
repeat time 10 min.

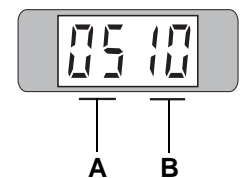

### 7.5.2 Start position for BGM CDs and configuration

Press button 8. The start position of the BGM CDs is displayed in the left two digits. The RH digits indicate whether BGM CDs can be selected over coin insertion or not.

A = start position of BGM CDs (01 = factory pre-setting)

B = 00 - BGM CDs can be selected

B = 01 - BGM CDs can NOT be selected

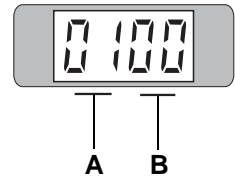

After entering this data the SCC unit calculates the BGM end position itself. For loading of BGM discs the end position can be calculated as follows:

$$\text{end position} = \text{start position} + \text{number of BGM CDs} - 1$$

**To reprogramme** press selection button 8 - hold - and press selection button R. The digital display goes dark. Enter start position and the selection option with 4 digits!

### 7.5.3 BGM time zones at different weekdays

You can programme each weekday differently with two intervals per day. The following steps are the same for the buttons 1 to 6 in service level 3 according to the table for weekdays..

- |               |              |
|---------------|--------------|
| 0 = Sunday    | 4 = Thursday |
| 1 = Monday    | 5 = Friday   |
| 2 = Tuesday   | 6 = Saturday |
| 3 = Wednesday |              |

1. Press button 0, the display shows flashing:

- ⇒ 0 (LH) = Sunday
- ⇒ 1 means start time one,

then the time will be displayed, here 9.00 o'clock.

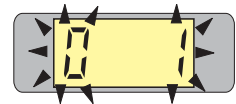

2. Press selection button 0 again, the display shows flashing:

- ⇒ 0 (LH) = Sunday
- ⇒ 2 means stop time one,

then the time will be displayed, here 12.30 o'clock.

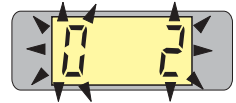

3. Press selection button 0 again, the display shows flashing:

- ⇒ 0 (LH) = Sunday
- ⇒ 3 means start time two,

then the time will be displayed, here 20.00 o'clock.

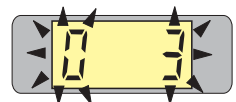

4. Press selection button 0 again, the display shows flashing:
  - ⇒ 0 (LH) = Sunday
  - ⇒ 4 means stop time two,

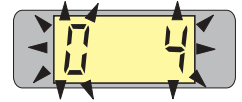

then the time will be displayed, here 23.45 o'clock.

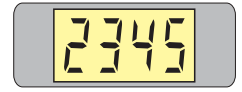

**To programme** press selection button 0 (or button 1 - 6 depending on the weekday to be programmed), hold it and press selection button R. The digital display goes dark. Enter the two time zones in four blocks containing four digits per block one after the other (16 digits).

Examples:

The jukebox should play BGM on Tuesday from 9.30 to 11.45 and from 17.00 to 19.55. To programme press selection button 2 - hold - and press selection button R. The digital display goes dark.

Then enter 0-9-3-0-1-1-4-5-1-7-0-0-1-9-5-5.

If the jukebox should play BGM on Wednesday from 17.00 to 19.55 only, then programme selection button 3 as described: 1-7-0-0-1-9-5-5-0-0-0-0-0-0-0-0. The second time zone has to be filled with zeros. Also this programming is possible:

0-0-0-0-0-0-0-0-1-7-0-0-1-9-5-5.

Meaning of the digits to be entered in the example

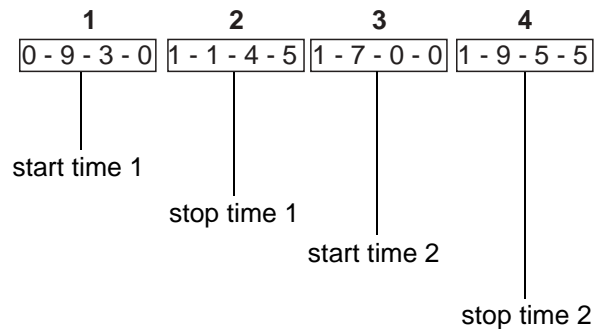

**Repeat this procedure until all weekdays are programmed (selection buttons 0 to 6).**

**Exit the service program:**

1. Set the slide switch 'service' at the SCC unit to OFF.
2. Press 'LT' button.
- The changer starts an initialisation run. After this the jukebox is ready to operate.

## 7.6 HappyHour pricing (additional bonus plays)

During the HappyHour time additional bonus plays can be given. HappyHour time zone and number of additional bonus plays have to be programmed as follows.

### 7.6.1 Programming of the HappyHour start and stop time, level 2 button 6

1. Set the slide switch 'service' at the SCC unit to ON.
2. Press 'LT' button.
3. Press selection button 4 -hold down- and press selection button R, then release both buttons. The display is dark. Service level 2 is reached.
4. Press selection button 6. The display shows flashing:
  - ⇒ 1 means start time
  - ⇒ then the start time will be displayed with four digits e.g.: 9.00 o' clock
5. Press selection button 6 again. The display shows flashing:
  - ⇒ 2 means stop time
  - ⇒ then the stop time will be displayed with four digits e.g.: 12.30 o' clock
6. To reprogram press selection button 6 - hold - and press selection button R. The digital display goes dark.
7. Enter the HappyHour start and stop time with 8 digits. After complete entry the digital display is dark.
  - ⇒ Example: HappyHour should operate from 09.05 to 11.00 o'clock.
  - Enter 8 figures: 0 - 9 - 0 - 5 - 1 - 1 - 0 - 0 .
8. To check the settings: Repeat the steps 4 and 5.

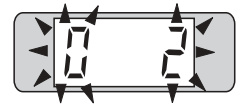

### 7.6.2 Programming of the additional bonus plays, level 2 button 7

1. Press selection button 7. The display shows additional bonus plays during Happy hour, e.g.:
  - ⇒ 1 additional play at bonus level 4 (B4)
  - ⇒ 3 additional plays at bonus level 3 (B3)
  - ⇒ 5 additional plays at bonus level 2 (B2)
  - ⇒ 7 additional plays at bonus level 1 (B1)
2. To reprogram press selection button 7 - hold - and press selection button R. The digital display goes dark.
3. Enter the new HappyHour pricing with 4 digits.
4. To check the new setting, press selection button 7 again.
5. To exit the service program set the slide switch 'SERVICE' to OFF and press button LT.

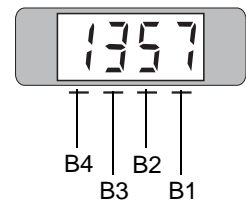



## 7.7 Number of tracks played successively on the same disc, level 2 button 3

The display shows the maximum number of tracks played successively from the same disc. Preset value = 04 tracks, i.e. after four tracks from this CD have been played it will be taken back to the magazine, and the next CD stored in the selection memory will be played. If selections still exist for the previous CD they will be played later. This option to limit the tracks played from one CD is more useful for operators. For individual use this value can be set up to 99.

To call the service program (level 2):

1. Set the slide switch 'service' at the SCC unit to ON.
2. Press LT button.
3. Press selection button 4 -hold down- and press selection button R, then release both buttons. The display is dark.
4. Press selection button 3 the display shows e.g.:  
04 = factory setting for number of tracks played successively on the same disc.
5. To reprogramme press selection button 3 - hold - and press selection button R. The digital display goes dark.
6. Enter the desired setting by means of the selection buttons with two digits, possible entries are 01 - 25.



**NOTE: If you set this value to 01 all selections will be played in selection order.**

7. To check the settings: Press selection button 3 again.
8. To exit the service program set the slide switch 'service' at the SCC unit to OFF and press the 'LT' button once.

The changer starts an initialisation run. After this the jukebox is ready to operate.

## 7.8 Album selection and memory reset by power off, level 2 button 9

By setting the corresponding digit these options are available.

**Album selection** is possible by entering the disc number followed by 0 0 (track 0 0). All tracks on the CD are played, starting with the first track. An album is only selectable by coin insertion, if credits of the 4th bonus level have been obtained or in free play modus (link in row GP from 0 to F on the SCC unit) of the jukebox.

**Memory reset** feature will cancel remaining credits and selections by power off of the jukebox. This option prevents the jukebox playing preselected tracks from the day before (the jukebox was switched off in the night.).

To change the settings (Service program, level 1):

1. Set the slide switch 'service' at the SCC-unit to ON.
2. Press 'LT' button.
3. Press selection button 4 -hold down- and press selection button R, then release both buttons.
4. Press selection button 9, the display shows e.g.:
  - ⇒ A = digit for memory reset by power off; 1 = ON, 0 = OFF
  - ⇒ B = digit for albumplay; 1 = ON, 0 = OFF
5. To change the settings press selection button 9 -hold down- and press selection button R. The digital display goes dark.
6. Enter the desired setting with two digits.
7. To check the settings: Press selection button 9 again.
8. To exit the service program set the slide switch 'service' at the SCC unit to OFF and press the LT button.

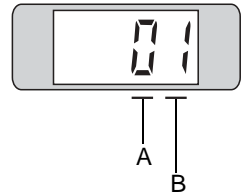

## 7.9 Disabling single tracks

You can disable up to maximum 25 different tracks of different CDs. If somebody selects a disabled track the digital display flashes. This shows that this track is not selectable. Note a special peculiarity at playstimulator or BGM operation. The random procedure always selects tracks out of a number of 25 per CD. If the random selected track exceeds the number of tracks on the CD the procedure starts to count from the beginning of the CD. Result is, if you want to disable e.g. track 8 on a CD with 17 tracks you also have to disable track 23 on this disc although it does not really exist.

To disable tracks (service program level 2):

1. Set the slide switch 'Service' at the SCC-unit to ON.
2. Press 'LT' button.
3. Press selection button 4 -hold down- and press selection button R, then release both buttons.
4. Press selection button 4 the display shows e.g.:
  - ⇒ On CD no. 15 track 08 is disabled.
  - ⇒ Each operation of selection button 4 indicates the next disabled track, maximum 25 tracks.
  - ⇒ After having reached the last disabled track, the first one is indicated again. If the display shows 0000 after the first button operation no track is disabled.
5. To programme: Press selection button 4 -hold down- and press selection button R. The digital display goes dark.
6. Enter at first the CD number to be disabled followed by the track number (total four digits).
7. To disable the next CD/track, press selection button 4 several times until display shows 0 0 0 0.
8. Press selection button 4 again -hold down- and press selection button R. The digital display goes dark.
9. Then enter CD and track to be disabled. Continue programming for the next track to be disabled with step 7.
10. To check the disabled tracks: Press selection button 4 again (up to 25 times, for 25 disabled tracks).

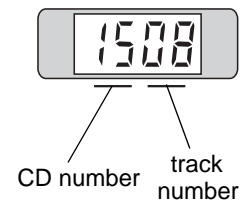

### To enable a disabled track:

When a track is indicated, press button 4 -hold down- and press selection button R and enter first the number of the CD followed by 0 0.

### To enable all disabled tracks:

Press selection button 4 -hold down- and press selection button R. Then enter 0 0 0 0 (4 times 0).

- To exit the service program set the slide switch 'service' at the SCC unit to OFF and press the LT button.

## 8 Data retrieval

The data retrieval memory stores data only if the plug 'MEMORY' is always in the position ON (on the RH side of the SCC unit).

You can read out statistical data in the service program level 1 over the display.

1. Set the slide switch 'Service' at the SCC-unit to ON.
2. Press 'LT' button.

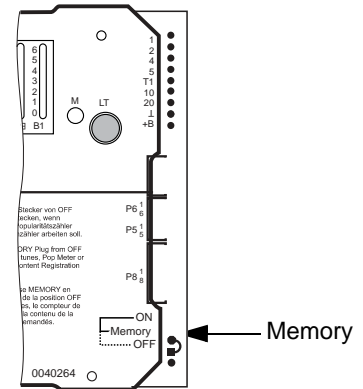

### 8.1 Retrieval of least popular discs (flops), level 1 button 0

1. Press selection button 0 once.
  - ⇒ At first the least played CD is shown. The last two digits are simply a code confirming the least played status. The display shows alternately the disc number and the number of plays e.g.:



- ⇒ If the counter shows 0 0 0 0, this means the disc has not been played. Press selection button 0 to continue the process for the second least played disc, and so on. At first the CD with the lowest number of plays will be displayed. Press button 0 again, the display shows the CD with the second lowest number of plays etc. If the calculation needs a little longer a '1' scrolls starting from RH. digit over the display.

2. To cancel the procedure press selection button R.

### 8.2 Top Tunes, level 1 button 1

1. Press selection button 1 once.
  - ⇒ The display shows alternately the number of the most played CD and the number of plays. For example:

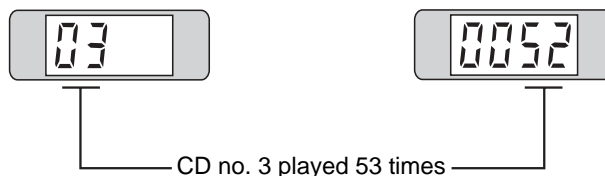

Only 60 selections per CD can be stored in the memory. If a CD has been played more than 60 times all the other values will be decreased by 1. The displayed values are only relative.

Press selection button 1 to continue the process for the second most played CD, and so on.

The most frequently played track will also be displayed as HIT OF THE HOUSE in normal operating mode.

### 8.3 Cash box contents, level 1 button 2

1. Press selection button 2 once. Digital display shows the cash box contents in basic units; basic units being the value of the lowest coin.
2. To cancel the procedure press selection button R.

### 8.4 Total number of plays, level 1 button 3

1. Press selection button 3 once. Display shows the total number of plays since last reset (maximum 9999).
2. To cancel the procedure press selection button R.

### 8.5 CLEAR ALL counters (reset to 0 0 0 0), level 1 button 3 + reset

1. Press selection button 3 -hold down- and press selection button R (reset).
  - ⇒ The counters belonging to the buttons 0 to 3 (least popular disc, most popular disc, cash box and total plays) are cleared and reset to 0 0 0 0.
  - ⇒ The sequence of top discs is for the time being 01, 02, 03, 04 etc.
  - ⇒ After leaving the service program the jukebox initializes itself, during this procedure the compartments in the magazines will be counted. At the end of the initialization the display should show either 0 0 0 0 for 100 CD carrier or 0 0 5 0 for 50 CD carrier.
2. To exit the service program first set service switch to OFF and then press the LT button.

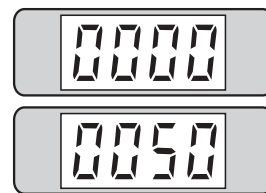

### 8.6 Memory of not playable CDs, level 1 button 6

Careful handling of the CDs does not completely exclude that CDs may be damaged in different ways. Possibly the player would interrupt this CD at each selection. The S&CC provides a watch dog function which finds and memorizes these difficulties to play. The S&CC unit can store the numbers of up to six not playable CDs. Once a CD is registered every new try will be counted. So it is possible to find out defective discs and exchange these for new ones.

1. Press selection button 6, the display shows flashing:
  - ⇒ 1 means first defective CD

then e.g.

  - ⇒ A = CD number
  - ⇒ B = NUMBER of times the CD was not playable or interrupted
2. Press selection button 6 to display the next not playable CD, etc. After displaying the 6th not playable CD and pressing selection button 6 again the display starts with the first one again.
3. To CLEAR this memory press selection button 6 -hold down- and press selection button R.
4. To exit the service program, first set service switch to OFF and then press LT button.

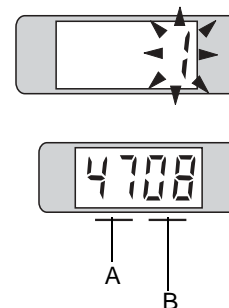

## 9 Amplifier K99

### 9.1 Device description of the amplifier K99

The amplifier K99 is optimised for universal use in Deutsche Wurlitzer GmbH music machines. Great importance had been attached for an easy handling and stand alone function without the S&CC unit. The output power is designed for the typical used internal speakers at Deutsche Wurlitzer GmbH machines, under normal circumstances reaching an impeccable volume level.

#### Standard equipment:

- Hybrid power stage technology, short circuit and over temperature protected
- 2 inputs (stereo): CD and tape
- 1 mono input for optional micro kit
- Volume control with 2 pots onboard
- Volume control possible with pots and / or IR at the same time. The pot used at last determines the volume.
- Bass and treble control with pots
- BGM volume reduction, controllable with pot
- Automatic volume correction (AVC), switchable
- 2 channel operation switchable, RH = internal speakers, LH = external speakers
- Status display with 7segment display
- Independent controllable RCA output to connect external amplifiers
- For use with the old and the new changer mechanism.

#### Optional:

- Remote control with large distance range. Functions: track selection / volume chan. 1 / volume chan. 2 / mute (toggle) / cancel
- Volume control with two pots in the wired remote box accessible from the machine rear wall, or external. Cancel button and mute button (with toggle function).
- Output transformer
- Microphone kit

### 9.2 Technical data

	General	USA / Canada
Supply	100v - 240v	117v
Mains frequency	50cps - 60cps	60cps
Input voltage CD	typ. 1.2v	typ. 1.2v
Input voltage tape	300mv	300mv
Output voltage pre amplifier	<=1veff	<=1veff
Output power	2 x 55w (rms)	2 x 55w (rms)
Output impedance	min. 4ohm	min. 4ohm
Transmission range	20cps - 20,000cps	20cps - 20,000cps
Distorsion factor	< 1%	< 1%
Noise level	depending on the adjusted volume of the jukebox loudness levels of more than 70 dB(A) can be reached.	

### 9.3 Verification of power voltage

The voltage settings are marked on the cover plate of the mains transformer. Machines for USA are set to 117V. They have a special transformer according to UL standard which is not adjustable. Jukeboxes "UNI-Pack" are shipped in 230V setting. This is marked on the machine label inside of the door. If the voltage setting is not clear the transformer cover plate has to be removed. The mains fuse (T3.15A) is located on the left bottom side inbetween the three terminals for the bill acceptor, the external mains switch and the fluorescent lamps.

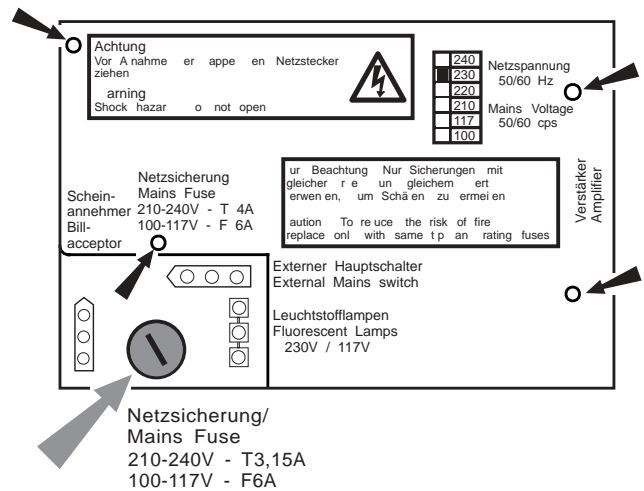

Loosen the four screws to remove the cover plate (small arrows).



**ATTENTION!** Always remove power plug before opening transformer cover plate. Never attempt any intervention to these parts unless qualified!

The position of the two plug connectors on the transformer terminals 1 to 9 (primary side) indicates the current voltage setting. The following combinations are possible:

- 240V = 1 - 9
- 230V = 1 - 8
- 220V = 2 - 9
- 210V = 2 - 8
- 117V = 1 - 6
- 100V = 2 - 6

Notice that these settings cannot be made on machines produced according to UL standard.



**NOTE:** Never connect the fluorescent supply to other contact.

If you intend to change the power voltage for a higher voltage (e.g. from 117V to 230V) it is better to use a subtransformer for the fluorescent lamps or change the ballast according to the used voltage (e.g. for 230V).

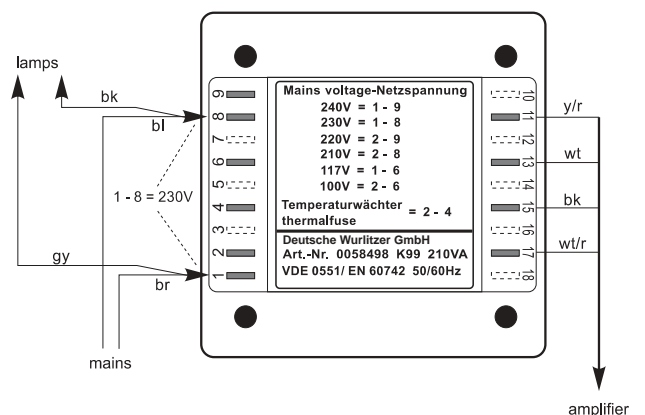

## 9.4 Position of fuses and plug connectors

Usually the jukeboxes are fitted with fuses of DIN 41571 (5x20 mm) slow blow or medium blow. Slow blow fuses of DIN standard bear the letter T (T = "Träge") e.g. T 4/250 means T = slow blow, 4 amps, 250 V maximum operating voltage. Which fuses have to fit in is printed on the power transformer cover. Fast blow fuses (F = Flink) are unsuitable for the jukebox.

The fuse holders on the amplifier P.C.B. are also capable to hold fuses of 6x32 mm size.

You will find the fuses behind the amplifier cover plate. To remove the plate first unplug the cable coming from the mains transformer. Next lose slightly both nuts on top of the amplifier accessible through the holes in the cover plate (arrows). To remove the plate first take the bottom side out of its hinges and then the top side.

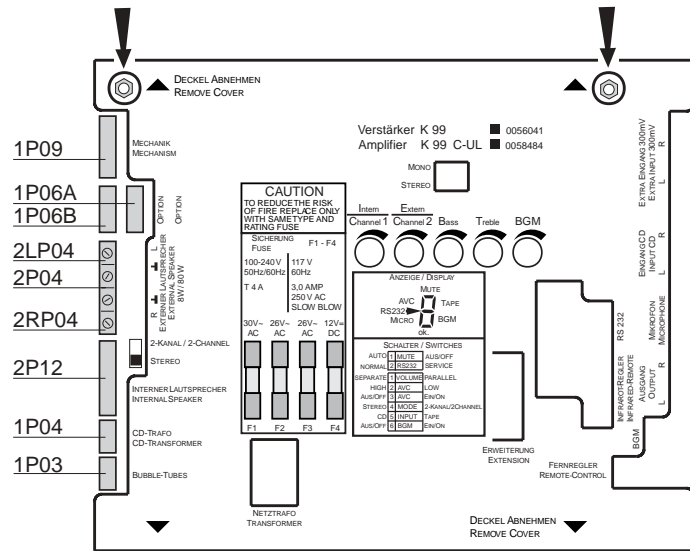

### Connection plan of the plug terminals:

- 1P09 - mechanism, SCC unit
- 1P06A - option
- 1P06B - option
- 2LP04 - external speakers, LH
- 2P04 - external speakers, ground
- 2RP04 - external speakers, RH
- 2P12 - Internal speakers
- 1P04 - CD sub transformer, CD player
- 1P03 - bubble tubes

### Fuse

Main fuse T 3,15, res. F6 A for 110/117 V.

Fuse F1: T4A supply 30V ~

Fuse F2: T4A supply 26V ~

Fuse F3: T4A supply 26V ~

Fuse F4: T4A supply +12 V=

### Failure

No illumination, machine completely dead.

The digital digit on the CD-control is dark. Power supply for CD player and control unit is interrupted. Credit circuit via LED M is interrupted. If credits are still in memory or free play is programmed; a CD will be placed on turntable but is not spinning.

The colour tubes of the One More Time do not rotate, the heating of the bubble tubes is off - no bubbles will appear. Possibly defect of the power stage of the amplifier.

SCC unit dead - digital display dark (except red LED M still lighting up on coin insertion). The LEDs K and Z on the SCC unit are dark. No initialisations run after power ON. The status display on the amplifier is dark.



## 9.5 The first power ON

The mains switch is located at the rear side of the amplifier and thus it is on the rear side of the jukebox. For wall-boxes it is possible to connect an external mains switch to the amplifier accessible then from the side. In position 'I' jukebox and amplifier are switched on.

Up to approx. 1 sec. after power on random segments of the status display will light. Followed by displaying the version number of the amplifier software (1.0 or higher). Then the bottom segment for "ok." and the upper segment for MUTE will light. The amplifier is now in STANDBY MODE. Depending on other enabled options more segments may light as well (e.g. AVC).

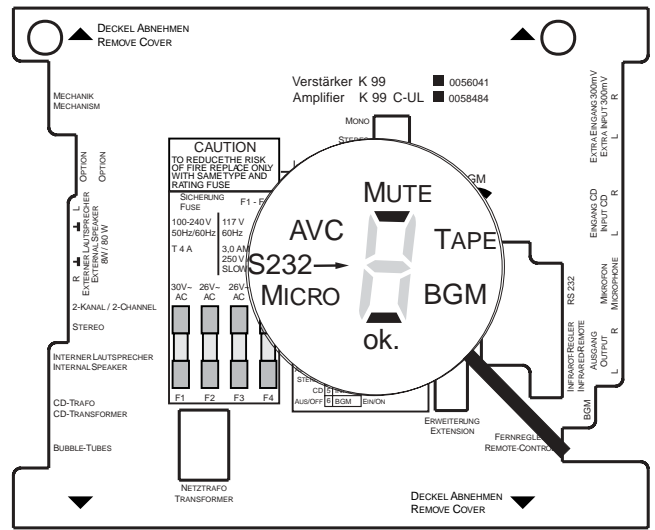

## 9.6 Volume control

You can control the volume of the jukebox from different points at the same time:

- With the pots Vol. 1 and Vol. 2 on the amplifier.
- With an optional connectable IR remote control.
- With the pots of the control box at the rear side of the jukebox.

The device from which the volume is changed determines it.

The volume control unit can be taken out and may be mounted at another place as a remote control. Its cable may be extended as required with any kind of wire. The voltages of the control wires are 5V DC.

The control box has two volume knobs (Intern / Channel 1 and Extern / Channel 2). In position "Stereo" the knob "Intern / Channel 1" is effective for the internal speakers. The knob Extern / Channel 2 is controlling the volume of the RCA outputs for an optional external amplifier. In DIP switch position "2 Channel" the channels 1 (RH) and 2 (LH) are controlled separately.



**ATTENTION!** The pots Vol. 1 and Vol. 2 on the amplifier are not effective if the wire control box is connected.

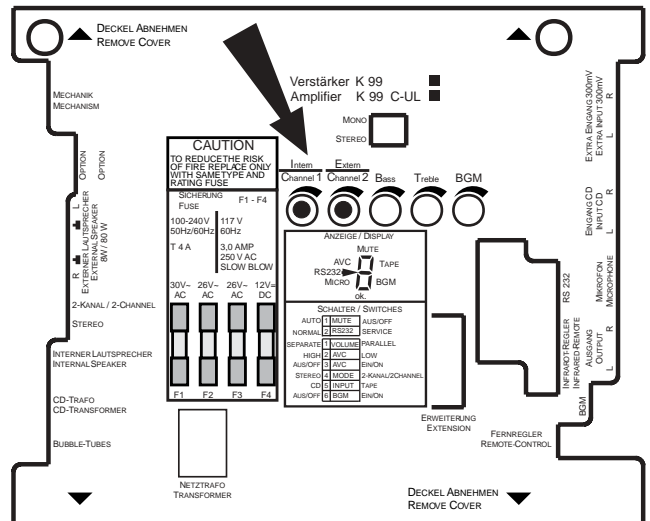

## 9.7 The infrared remote control

As desired an infrared remote control will be installed from factory or can be delivered as conversion kit (part no. 0058809). If it has been installed the hand transmitter is located in the cashbox.

If credit is given or free play is programmed a CD can be selected with the buttons 0 to 9 and R.

Double button functions as required in the service programs (i.e. press button 5 -hold down- and press button R), are impossible. For this you only can use the keyboard of the jukebox.

You can control the volume by means of the buttons + and -. In stereo mode the internal +/- buttons control the volume of the internal speakers. The external +/- buttons control the volume of the K99 RCA jacks for an optional external amplifier. In 2-channel mode you can control the external speakers by the buttons + and - of the external channel.

Beam the jukebox directly if possible.

You can connect the wire remote control box as well.

The power-on volume level is always set by the channel 1 and 2 pots on the amplifier or on the control box (if connected).

Batteries will be delivered. Necessary are 4 micro cells type LR03 (AAA).

To open the battery compartment move the cover like shown in the picture.

Needed battery type and position of the batteries in the hand transmitter are shown on the casing.

Part no. of the hand transmitter: 0059745.

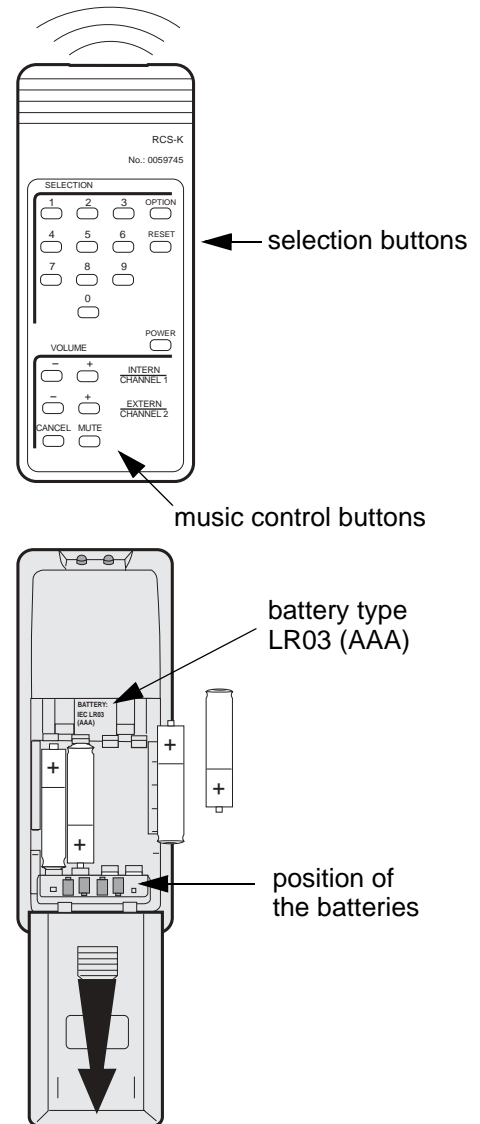

## 9.8 Treble and bass control

You can control the sound with the knobs bass and treble on the amplifier.

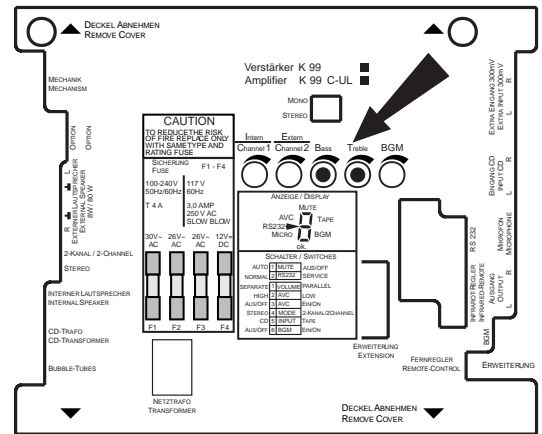

## 9.9 Automatic volume correction

The AVC sets CDs with different volume levels to an equal level. The level of CDs with a high level will be reduced; the level of low-levelled CDs will be increased. This control works rather slow to save the dynamic range of the track.

You can enable the correction with the DIP switch "AVC" (the 3rd switch of the 6 sw. group). Default is AVC disabled.

With the second DIP switch of the 6 sw. group you can reduce the intensity of the volume correction.

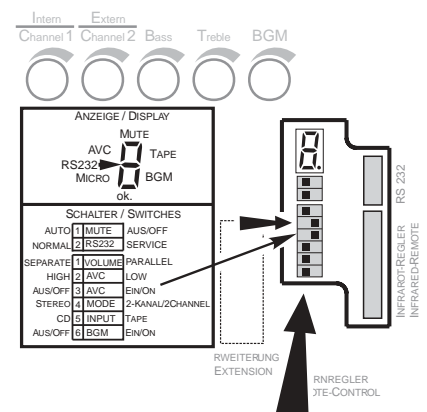

## 9.10 Background Music - volume attenuation

In the BGM (Back Ground Music) mode the reproduction volume will be reduced by a certain factor.

The signal "BGM" pin 1 plug brown of the SCC unit controls this function. You also can switch on "BGM" by means of the DIP switch "BGM" for test purposes. The RH bottom segment of the status display on the amplifier indicates "BGM active". You can adjust the volume attenuation with the pot "BGM", as long as it is active.

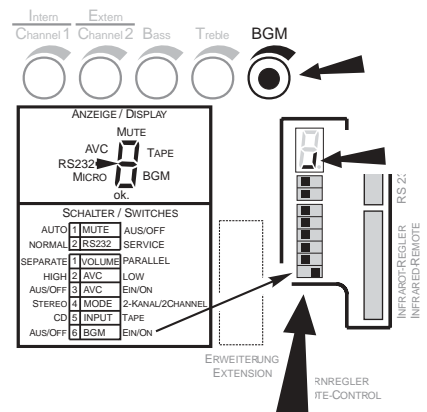

## 9.11 External speaker connection

The amplifier can operate in two different modes. The normal operation mode reproduces the music in normal stereo sound. So external speakers can be added to each channel.

The so-called 2-Channel mode uses both stereo channels like separate mono amplifiers so that the sound can be reproduced in different rooms but then in mono only.

The amplifier may not be loaded with more than 4 ohms per channel (less ohms means more load!). On an overload it switches itself off. After a certain cool down time it switches itself on. So if you do not eliminate the reason for the overload the amplifier produces continuously volume dropouts. The impedance of all external speakers per channel in "Stereo" mode should not be less than 4 ohms.

The amplifier applies approx. 55 watts (rms on max. 1% dist.) on a 4 ohms speaker per channel, 18 watts to a 12 ohms speaker and approx. 9 watts to a 24 ohms speaker. That means, that e.g., a 12 ohms speaker connected to the external channel at Dual Channel operation must be a type of at least 18 Watts, otherwise the speaker is in danger of destruction at higher volumes. Note that speaker groups like in hi-fi boxes may have, at certain frequencies, impedance much lower than their rating. Make sure that all speakers are connected in correct polarity.

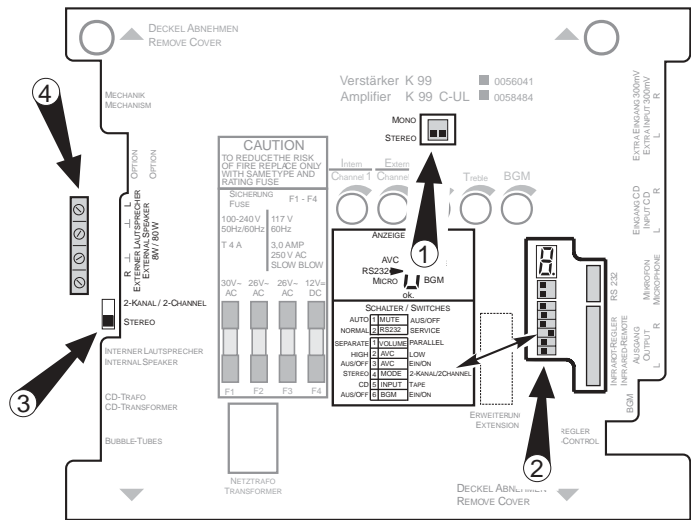

Position of the Stereo - Mono DIP switch (1), the mode switch in the 6 sw.group (2), the stereo - 2 channel switch (3) and the external speaker terminals (4).

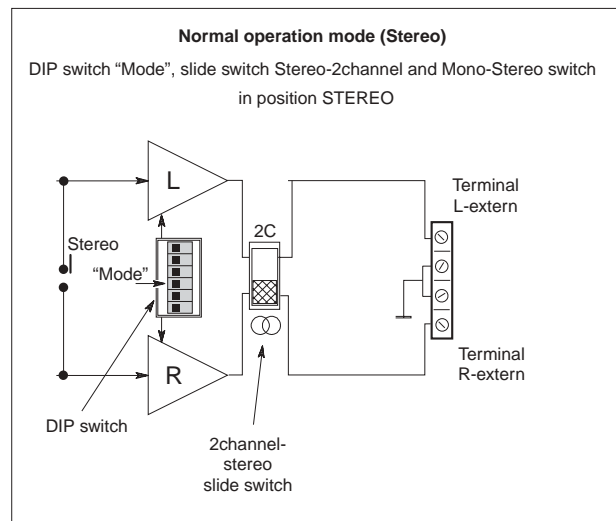

Connect external speakers to the screw terminals on the LH amplifier side.

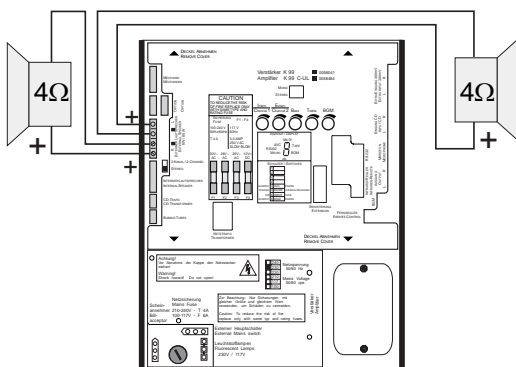

Two speakers of 4ohm also represent total impedance of 8ohm.

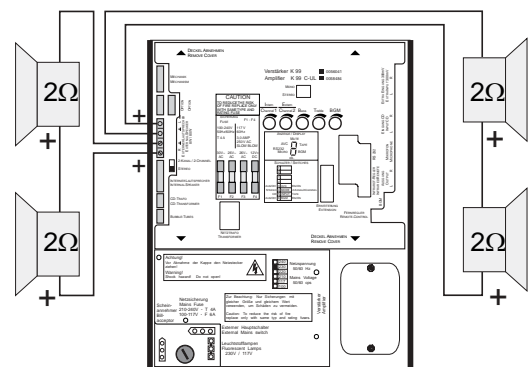

## 9.12 External amplifier connection

On the RCA terminals “Ausgang - Output” you can connect an external amplifier with any power rate. In Stereo mode the output level is normally controlled by means of the pot for the 2nd channel. Alternatively you can set the first DIP switch of the 6 sw. group to ON to couple this output to the normal volume control knobs (1st channel), so that both amplifiers can be controlled together.

Connecting an external amplifier in 2-channel mode is not useful.

To avoid hum- (earth-) loops try to use an external amplifier with ground insulation; it has no earth contacts. If it is impossible (e.g. receivers with cable supply) you can separate both amps by means of the ground isolator part no. 0053300.

The signal of the RCA terminals is also controlled by the settings of bass, treble, BGM, AVC and Mute.

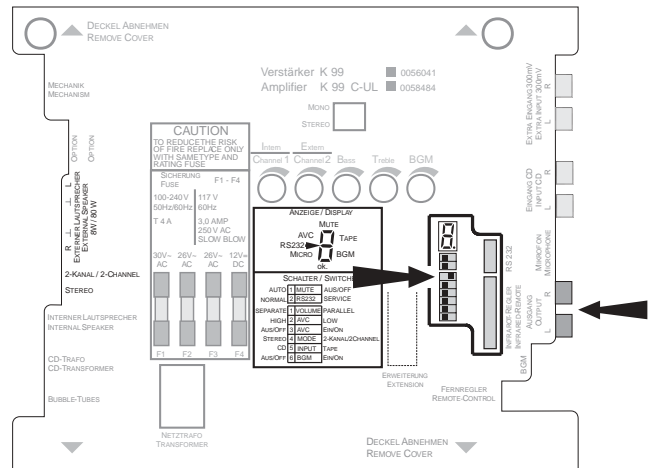

## 9.13 Disabling the internal mute circuit

With the optional BGM-Connector (part no. 0048133) you can connect an external source to the jukebox. In this case the amplifier should not be muted during standby of the jukebox.

Please switch off the internal mute circuit by setting the first DIP switch of the 2 sw. group “Mute” to OFF.

For more information order the Deutsche Wurlitzer GmbH technical information leaflets TI-MA-116.

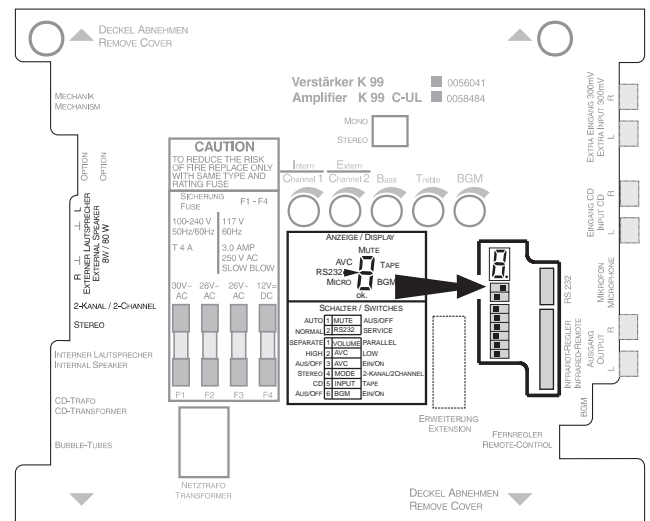

FIELD SERVICE MANUAL

## 9.14 Input selector

With the 5th DIP switch of the 6 sw. group you can set either CD or tape input as active.

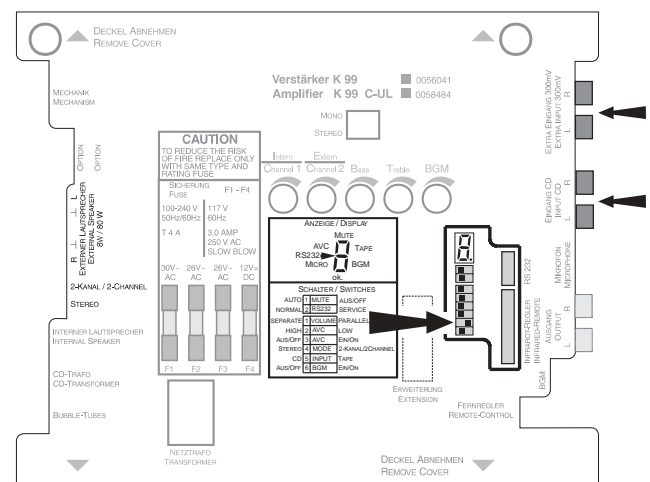

# 10 Amplifier F91

The amplifier F91 is the version with higher power output (2 x 170 W rms.). Equipped with protection and watch dog functions described below. The BGM adapter (to attenuate the volume in BGM mode) is integrated. The amplifier is equipped with an automatic volume control (AVC) to level out different recording levels.

In 2-channel mode it is possible to control both channels separately with the IR-remote control.

You can also make selections with the optional infrared remote control.

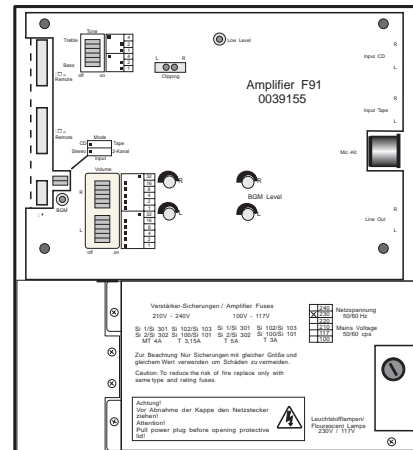

## 10.1 Verification of power voltage



**ATTENTION!** Always remove power plug before opening transformer cover plate. Never attempt any intervention to these parts unless qualified.

The power voltage setting is on the cover plate of the F91 transformer. Machines for USA are set to 117 V. Jukeboxes „UNI-Pack“ are shipped in 230 V setting. This is marked on the machine label inside of the door. If the voltage setting is not clear the transformer cover plate has to be removed.

The mains fuse (T3,15 A, res. T8 A for 117V) is located near the RH side of the cover plate.

The position of the two plug connectors on the transformer terminals 1 to 9 (primary side) indicates the current voltage setting. The following combinations are possible:

240V = 1 - 9

230V = 1 - 8

220V = 2 - 9

210V = 2 - 8

117V = 1 - 6

100V = 2 - 6

**Never connect the fluorescent supply to other contacts.**

If you intend to change the power voltage to a higher voltage (e.g. from 117V to 230V) it is recommended to use a subtransformer for the fluorescent lamps or change the ballast according to the used voltage (e.g. for 230V).

The power consumption in standby is approx. 146W. With max. volume it is approx. 540W.

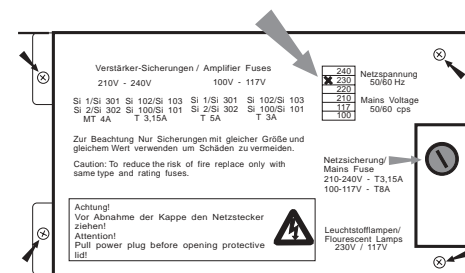

Loosen the 4 screws to remove cover plate (small arrows)

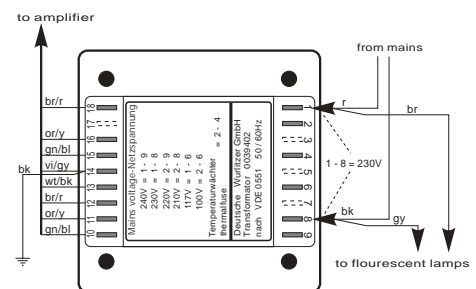

## 10.2 Position of fuses and plug connectors on the power amp board



**WARNING!** A voltage of approx. +60V res. - 60V applies to the fuse terminals also a certain time after power off. Change the fuses with caution !

Usually the jukeboxes are fitted with fuses of DIN 41571 (5x20 mm) slow blow or medium blow. Slow blow fuses of DIN standard bear the letter T (T = "Träge") e.g. T 4/250 means T = slow blow, 4 amps, 250 V maximum operating voltage. Which fuses have to be used is printed on the power transformer cover. Fast blow fuses (F = Flink) are unsuitable for the jukebox.

The fuse holders on the amplifier P.C.B. are capable to hold also fuses of 6x32 mm size.

### Position of the plug connectors

P12 - jukebox speakers

P 3 - bubble tubes

P16 - power transformer

P 4 - CD sub transformer, CD player

P 9 - mechanism, Selection and Credit Computer

P 6 - option, coin interface

P6A - option

P 7 - service

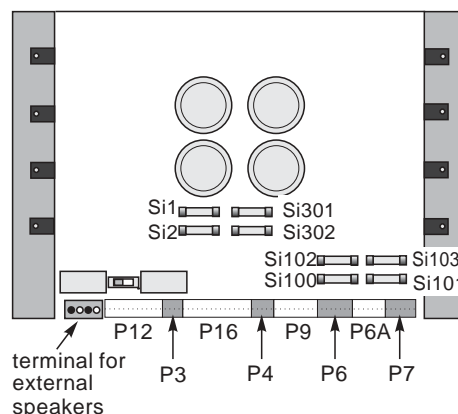

### Fuse

Main fuse T 3,15, res. T8 A for 110/117 V.

Fuse Si1: T4A (T5A) +70V= L.H. channel power stage

Fuse Si2: T4A (T5A) -70V= L.H. channel power stage

Fuse Si301: T4A (T5A) +70V= R.H. ch. power stage

Fuse Si302: T4A (T5A) -70V= R.H. ch. power stage

Fuse Si100: T3,15A (T3A) supply -30 V=

Fuse Si101: T3,15A (T3A) supply +30 V=

Fuse Si102: T3,15A (T3A) supply +12 V=

Fuse Si103: T3,15A (T3A) supply 30V ~

### Failure

No illumination, machine completely dead.

No sound in the L.H. channel. Speaker relay is not activated, green LED does not light.

No sound in the R.H. channel. Speaker relay is not activated, green LED does not light.

The jukebox operates normal. The CD2 mechanism does not use this voltage.

No initialisation run after power ON. Display working. No function.

SCC unit dead - digital display dark (except red LED M still lighting up on coin insertion).

The LEDs K and Z on the SCC unit are dark. No initialisation run after power ON.

The digital digit on the CD-control is dark. Power supply for CD player and control unit is interrupted. Credit circuit via LED M is interrupted. If credits are still in memory or free play is programmed, a CD will be placed on turntable but is not spinning. After about one minute the CD is taken back.

If no credits in memory, no CD will be taken to turntable, the display is flashing.



### 10.3 The first power ON

The mains switch is located at the bottom left hand rear side of the jukebox. In position 'I' jukebox and amplifier are switched on. The amplifier is now in STANDBY MODE:

The yellow 'Low Level LED' lights.

The 'Low Level' circuit detects low music parts and pauses. It effects the AVC circuit not to raise the audio level in music pauses. So disturbing noises will not be heard. This LED may light for short times during play.

The yellow 'Mute LED' lights (on the power amp board, only visible after lifting up the pre amp board). It indicates that the amplifier is muted.

To avoid power on and other noises, the amplifier output will be switched on only during play.

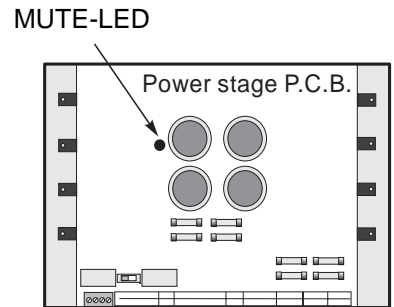
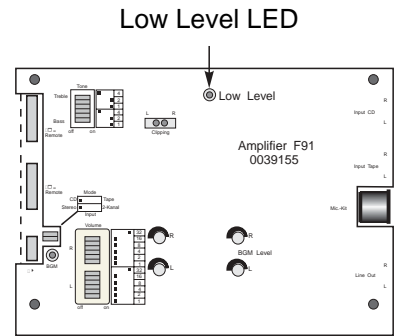

### 10.4 Pre-settings for volume, bass, treble

After power on of the jukebox or after pressing the button 'preset' the levels of volume, bass and treble will be set to basic values. These values can be set with different binary DIP switch combinations. The switches are located on the amplifier pre amp board. You can find the recommended settings on the amplifier cover.

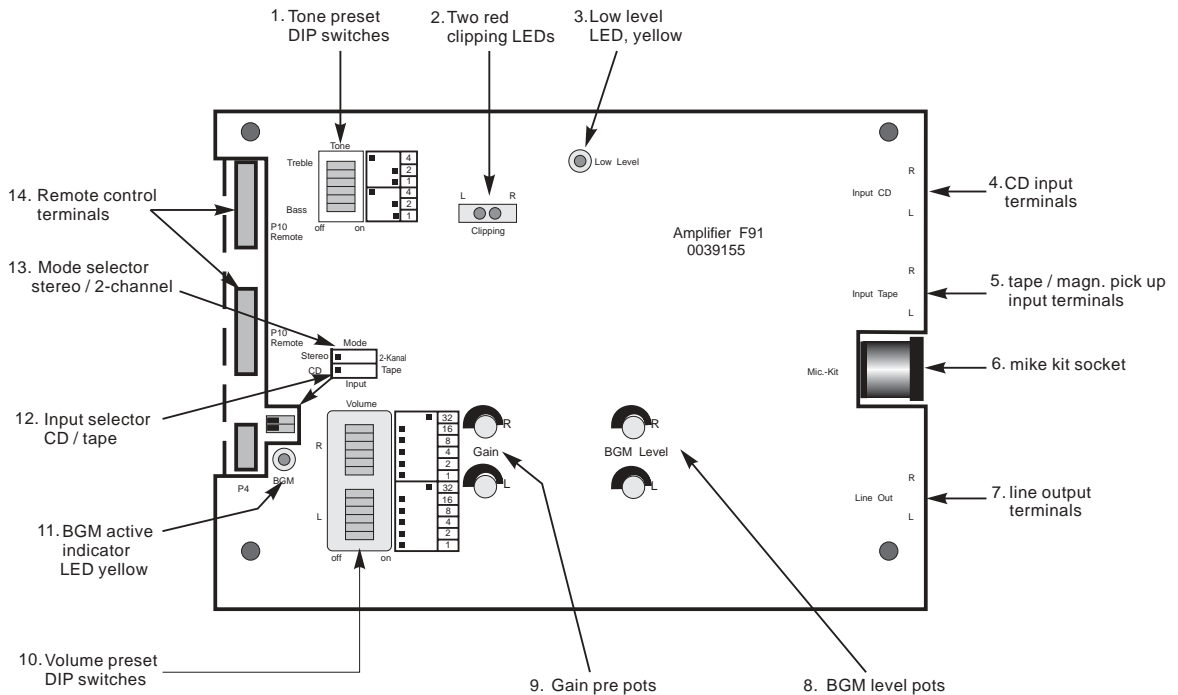





Speaker connections

Three DIP-switches with the values 1, 2, 4 are provided for each bass and treble. You can choose 7 different steps of 3dB from minimum (-9dB) to maximum (+12dB). Adding value of all switches set to "ON" gets the total value.

The 0dB - 'linear' position of these switches is printed as recommended factory setting on the amplifier cover.



**NOTE:** If you change the DIP-switch settings while the jukebox operates, new settings will be taken over after having pressed the button 'PRESET' at the control terminal or after a power off and on of the box.

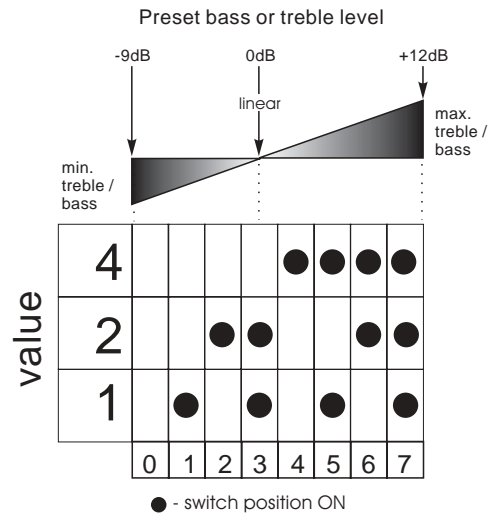

### 10.5 Speaker connections

The speaker connector terminals are situated inside and on the back side of the jukebox.

To attain a good sound of the jukebox, take care when connecting the speakers. Pay attention to the following requirements:

The minimum impedance is 4Ω per channel!

The power output of each channel at a load of 4Ω is 170 W rms, i.e. the min. power consumption of a 4Ω speaker set should be 200 Watts.

All speakers must be connected with the correct polarity.

The speakers may be operated as desired in the mode STEREO or 2-CHANNEL .

In STEREO mode the sound reproduction is always stereo.

In 2-CHANNEL mode it is possible to control the volume of both channels independent to each other. It allows to reproduce the sound in a second room with different volume. The sound reproduction in this mode is only mono.

In 2-CHANNEL mode the volume of the speakers connected to the normal terminals (R.H. channel) can be controlled with the mode 'VOLUME' and the volume of speakers connected to the screwing terminals on the amplifier (LH channel) with the mode 'BALANCE'. The preset volume can be set separately.

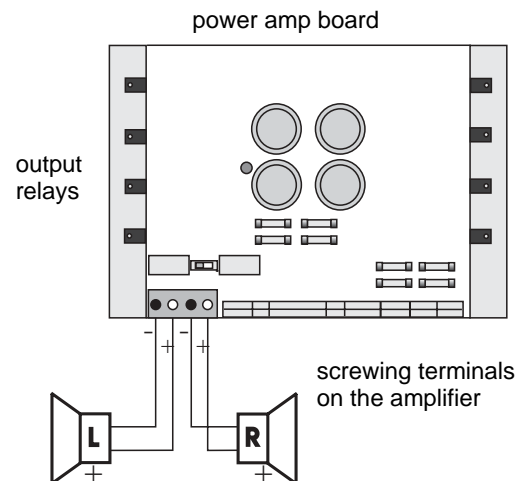
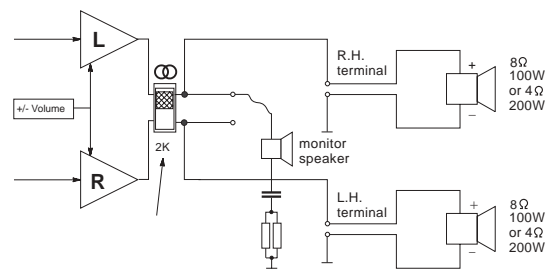

### 10.5.1 The operating mode STEREO

For normal operation the jukebox is set to the STEREO mode. Both amplifier switches, the mode switch and the slide switch S1 on the power amplifier board are set to position STEREO.

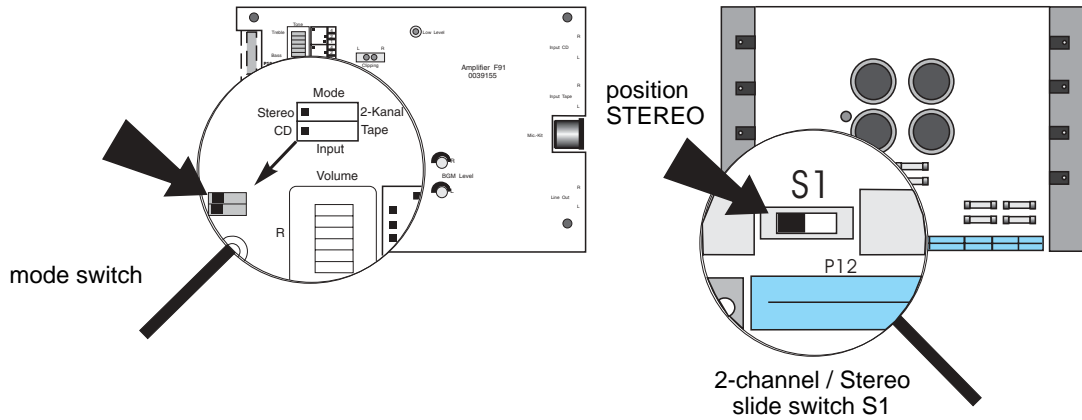

#### Example 1:

Two 8Ω speaker connected in parallel per channel

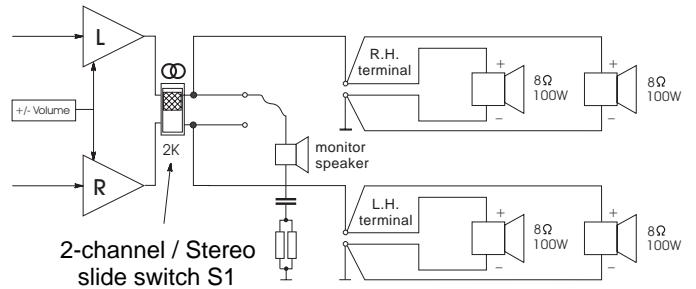

#### Example 2:

2 times 4 Ω speaker connected in series and in parallel with one 8 Ω speaker

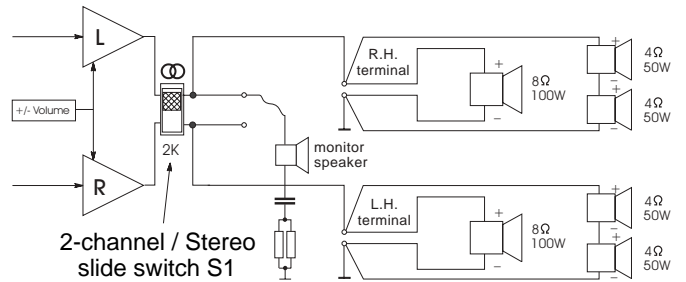

## 10.6 Connecting external speakers in operating mode 2-CHANNEL

For 2-CHANNEL operation both amplifier switches, the mode switch and the slide switch S1 on the power amplifier board are set to position 2-CHANNEL.

As the following examples show, in the 2-CHANNEL mode it is possible to connect different loads to each amplifier output. Take care that the min. impedance is  $4\Omega$  per channel.

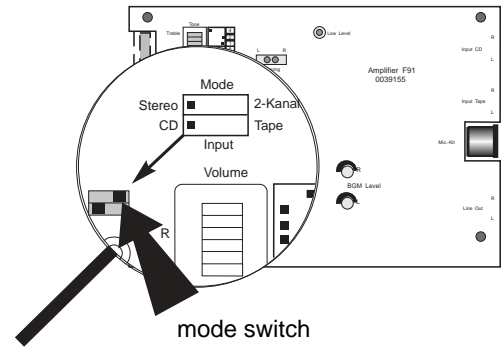

mode switch

2-channel / stereo  
slide switch S1  
in position 2-channel

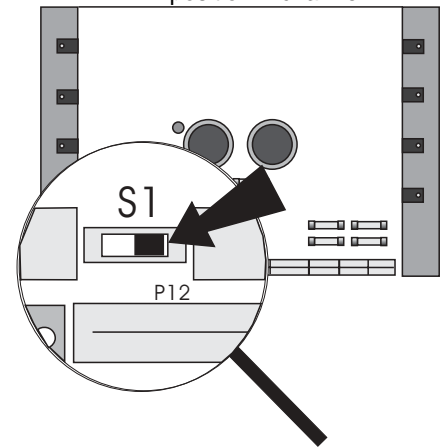

### Example 1:

1st room a speaker of  $4\Omega$  200W, 2nd room 4speaker of  $2\Omega$  30W connected in series

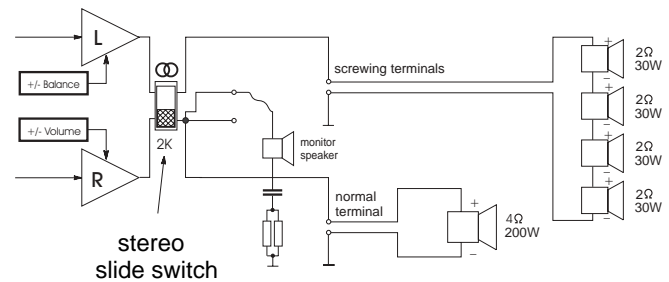

### Example 2:

1st room a speaker of  $4\Omega$  200W, 2nd room 4speaker of  $16\Omega$  50W connected in parallel

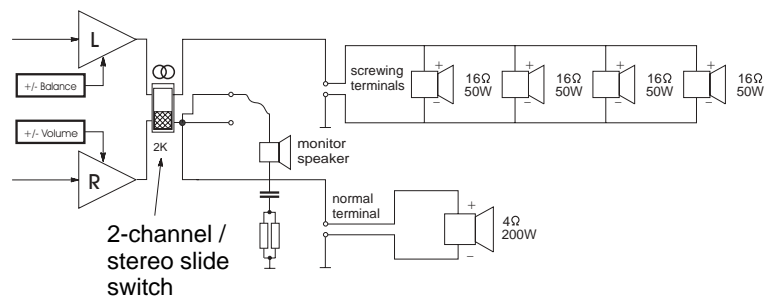

### 10.7 BGM mode - volume attenuation

In the BGM (BackGround Music) mode the volume will be reduced by a certain factor.

This function is controlled by the signal „BGM“ pin 1 plug brown from the SCC unit. The active BGM mode is displayed with a yellow LED near plug P4. In this mode the volume of the normal sound is adjustable by two BGM trim pots in the center of the pre-amplifier board.

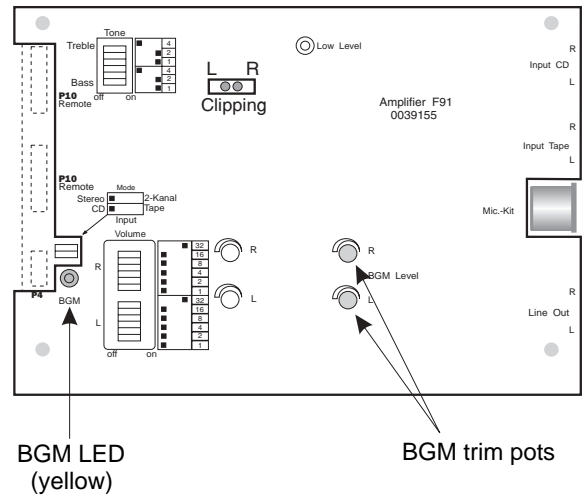

### 10.8 Automatic volume control (AVC) and clipping stage

The AVC sets CDs with different volume levels to an equal level. The level of CDs with a high level will be reduced, the level of low leveled CDs will be increased. This control works rather slow to save the dynamic range of the track.

The pre amp gain pots are situated between the volume pre-set switches and the BGM level trim pots. These two pots are factory pre set should **not** be adjusted.

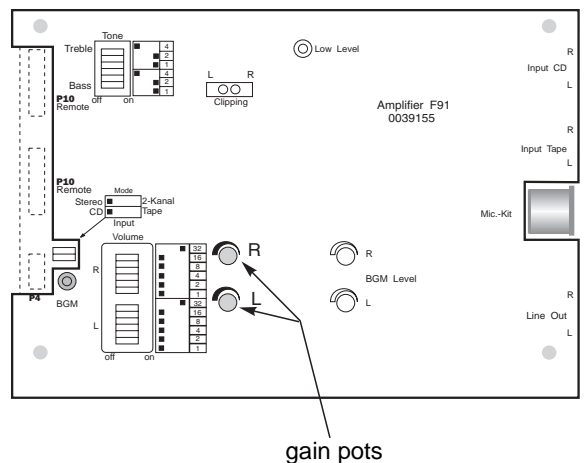

### 10.9 Overdrive protection

In case of an overdriven power amp one or both red clipping LEDs will light. The clipping circuit will have an effect on the AVC circuit and the volume will be reduced. Occasional lightning of the clipping LEDs during a loud performance is normal. Continuously lightning of one or both LEDs indicates an overdriven channel and distortion can be heard. It is recommended to reduce the volume.

Also speakers with an impedance lower than 4Ω (in STEREO mode) may cause an overload and the LEDs will light.

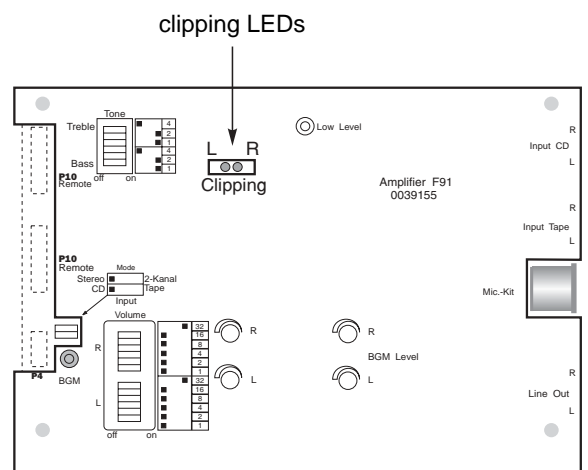

### 10.10 Overload protection

The power amplifier is provided with an overload protection circuit.

While the CD is playing two green LEDs indicate that the speaker output relays are activated. If one of these LEDs is dark during play and no sound appears an overload of the power amp stage has occurred, which is for example caused by a short circuit in the connection wires to the external speakers.

An additional internal watch dog circuit checks that the audio signal contains no DC Voltages and no high sublow frequencies. It also indicates that the load limitation cut off has been reached. If only one test is not successful the relays will be switched off.

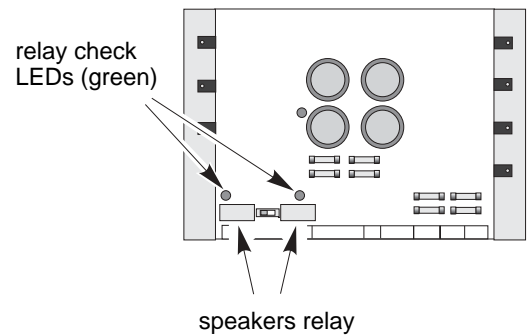

### 10.11 Tape input

Additional to the CD input a tape input with a higher input sensitivity is provided. As an option this input stage may be wired as a correcting network to work with a magnetic pick up (RIAA). Set the 'input' DIP switch to tape position to select the tape input.

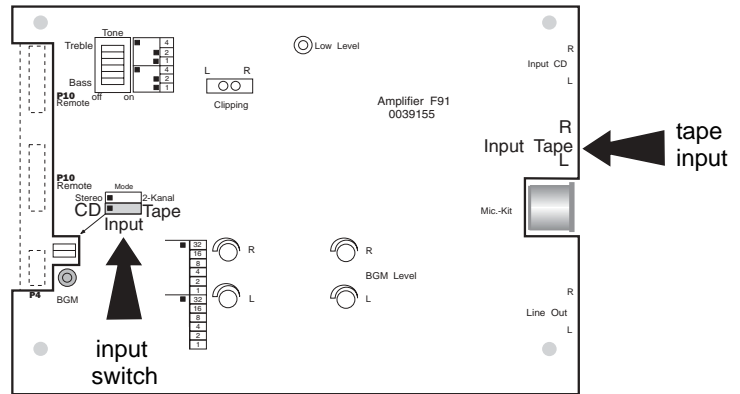

## 11 70v output transformer (0043157)

If you want to work with different speakers with any other impedances or with 70V systems, we recommend to use the output transformer. You can then connect speakers between 2Ω and 16Ω together but complete independent to each other.

If you want to connect several speakers by means of an output transformer pay attention to the following hints:

1. To avoid an interruption of all speakers by the overload protection circuit or a decrease of volume by the clipping stage, the total power outlet of the amplifier should not be exceeded.
2. All speakers must be connected with the correct polarity.
3. To operate each external speaker with the desired volume level, pay attention to the respective efficiency, impedance and load limit.
4. To avoid cable losses on long speaker lines (more than 60 feet) and low impedance, 70Volt-systems should be used as much as possible.
5. If speakers with low impedance (2Ω, 4Ω) are used, each speaker should have its own line with sufficient cross-section.
6. When an output transformer is used no speakers should be connected to the screwing terminals on the power amplifier board P4A.
7. Note: The 2-channel option can not be used in connection with an output transformer without modifying the pre-amp board.

The internal speakers can be operated with lower volume (switches on the connecting board). In position HIGH power consumption of the internal speakers is approx. 32W, in position LOW approx. 10W.

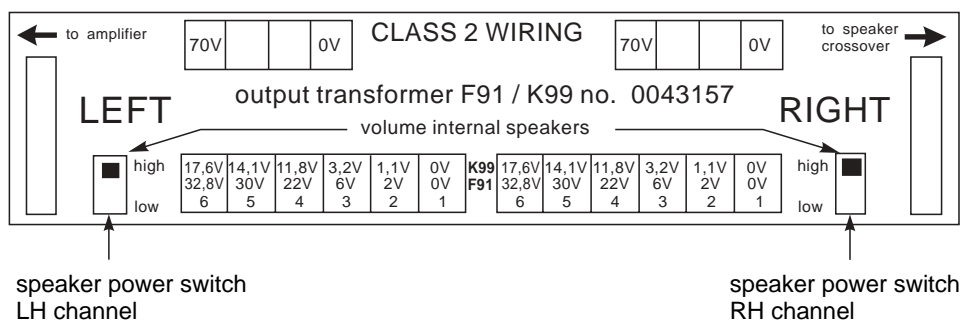

### 11.1 Hints of connectable speaker loads

The maximum power output per channel is 170 Watts (rms) for F91 and 55 Watts (rms) for K99. The power consumption of the connected speakers can be higher (i.e. 200 W) than the maximum remaining power outlet of the amplifier. If the power consumption is lower (i.e. 10 W) than the maximum remaining power outlet of the amplifier, it can be adapted by means of the output transformer.

## 11.2 Determination of the connectable speaker power

The real power consumption of a speaker equals the square of the voltage applied to the speaker terminals divided through the speaker impedance ( $P = U^2 / R$ ). The power values calculated in this way are shown in the following table. The volume level really delivered depends also on the speaker sensitivity and varies from type to type, but it is possible to level out these differences in certain limits.

## 11.3 Hints for speaker connection

- How much amplifier output will be used for the additional speakers, high or low.
  - 140W (F91) / 45W (K99) are available, if the speaker power switch is in position LOW.
  - 70W (F91) / 23W (K99) are available, if the speaker power switch is in position HIGH.
- The load of all speakers has to be added.
  - If the total load of all speakers per channel is higher than the delivered amplifier outlet power, not all speakers may work with the maximum power.
  - If the total load of all speakers per channel is lower than the delivered amplifier outlet power, all speakers may work with the maximum power, a power reserve additionally.
- For an efficient use of the speaker power the optimum impedance in conjunction with the output transformer connection possibilities has to be determined.

		Delivered maximum power in Watt if speakers with an impedance of xx Ohm are connected (F91/K99).						Voltage applied to the terminals in Volt <sub>rms</sub> F91/K99	Terminal number and polarity		
		16Ohm	12 Ohm	8 Ohm	6 Ohm	4 Ohm	2 Ohm		pos	neg	
LOW				0.5 F91	0.7/0.2	1/0.3	2/0.6	2/1.1	2	1	
				0.7 F91	1 F91	1.3/0.4	2/0.6	3.9/1.1	2.8/1.5	6	5
		1 F91	1.3/0.4	2/0.5	2.7/0.7	4/1.1	8/2.2	4/2.1	3	2	
		2.3/0.6	3/0.85	4.5/1.3	6/1.7	9/2.6	18/5.1	6/3.2	3	1	
		4/1.2	5.3/1.5	8/2.3	10.7/3.1	16/4.6	32/9.3	8/4.3	5	4	
		7.3/2.1	9.7/2.8	15/4.2	19/5.6	29/8.4	58/16.8	10.8/5.8	6	4	
HIGH		16/4.6	21/6.2	32/9.3	43/12.3	64/18.5	128/37	16/8.6	4	3	
		25/7.2	33/9.5	50/14.3	67/19.1	100/28.6	200/57.2	20/10.7	4	2	
		30/8.7	40/11.6	61/17.4	81/23.2	121/34.8	*	22/11.8	4	1	
		36/10.4	48/13.9	72/20.8	96/27.7	144/41.6	*	24/12.9	5	3	
		49/14.1	65/18.8	98/28.1	131/37.5	196/56.25	*	28/15	5	2	
		56/16.2	75/21.6	113/32.4	150/43.2	*	*	30/16.1	5	1	
	59/17.4	79/23.2	119/34.9	158/46.5	*	*	30.8/16.7	6	2		
	67/19.4	90/25.8	134/38.7	179/51.6	*	*	32.8/17.6	6	1		



## 11.4 Connection of 70v systems

70V systems are intended for transmissions over long distances. They also have their own transformer in front of the speakers. The primary (input-)side of this transformer has to be connected in correct polarity with the 70V terminals of the Deutsche Wurlitzer GmbH output transformer. It is not allowed to consume more power than the amplifier is able to supply (23W or 45W), minus the additional speakers eventually connected to the output transformer. At some 70V-systems the load is capable of variation.

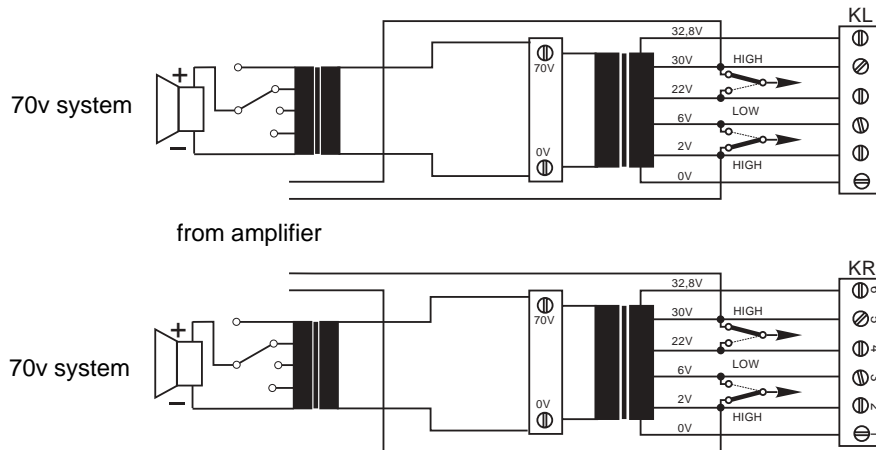

## 12 Amplifier I84

### 12.1 Fuses

Usually the machine is fitted with fuses of DIN 41571 (5x20mm) slow blow. Slow blow fuses of DIN standard bear the letter T (T = 'Träge'), hence T 3.15 is the proper type to be used. All fuses in the amplifier are rated T 3.15 250v.

The open holders of the LT fuses are capable to either 5x20mm fuses of DIN 41571 standard or fuses of 6x30mm size. Fast and medium blow fuses are unsuitable for the machine.

Only exceptions are countries with 110/117v supply where a fast blow fuse of 6.3amps (F6.3 of 6x30mm size) is used for the primary fuse.

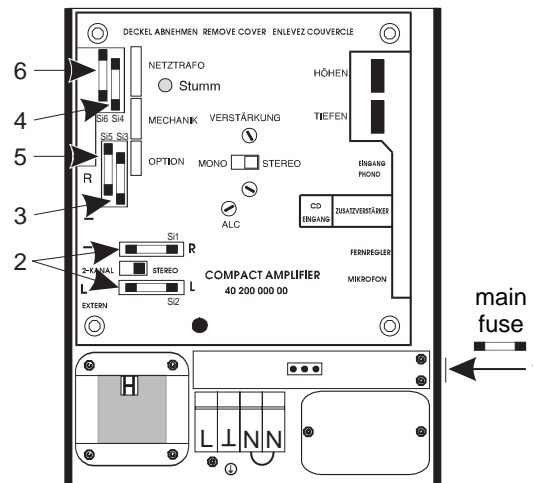

Fuse (number)	Failure
1 Main fuse T 3.15 At 110/117v supply F6.3	No illumination, jukebox completely dead.
2 Suses Si1 and Si2: speaker fuses	No sound on LH channel (Si1) or RH channel. the reason for a blown fuses here might be a shorted power transistor.
3 Fuse Si3: 30v negative supply	Amplifier distorting on both channels, green LED 1 not lit. Gripper arm is still moving. Digital display shows a <b>flashing 8</b> on the RH digit.
4 Fuse Si4: 30v positive supply	Amplifier silent though the red LED (mute) is dark. <b>Gear motor not working.</b> After power on disc carrier moves on and stops, relay M3 picks up, after that no further function.
5 Fuse Si5: 12v positive supply	S&CC unit dead - digital <b>display is dark</b> (except red LED M still lightning up on coin insertion).
6 Fuse Si6: 30v AC supply	Disc <b>carrier motor KM not working</b> , power supply for CD control unit ( <b>one digit display dark</b> ) and CD player interrupted. Break in credit circuit (LED M). After power on carrier latch solenoid picks up, digital display shows 0000 and then no further function.

## 12.2 Volume control

The control box, accessible from the rear side of the jukebox, is a separate unit and has two knobs (L and R). In „stereo mode“ (switch S in position stereo) only the left knob is effective. In position „2 Kanal“ (two channel) of the slide switch both channels are controllable separately.



**NOTE:** The volume control unit can be screwed off and may be mounted at another place as a remote control.



**ATTENTION!** Depending on the adjusted volume of the jukebox noise levels of more than 70 dB can be reached.

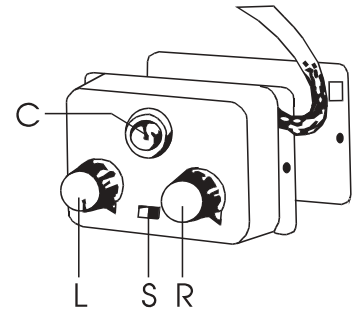

## 12.3 Automatic loudness controller

An internal automatic volume controller decreases the volume level of CDs recorded too loud to an output level defined by the ALC pot. So an equal volume level is reached. The ALC pot is pre-set from the factory. In left position of the adjustment pot the ALC does not operate.

## 12.4 Treble and bass control

The treble and the bass controls at the top RH-side of the amplifier may be set to any position to suit local acoustic requirements. The Mono-Stereo switch may also be be set to either position, however, it must be set to 'Stereo' if a stereophonic reproduction is desired.

## 12.5 Slide switch 'Stereo/2-Kanal'

In standard operating mode the slide switch „Stereo/2-Kanal“ is in position „Stereo“. In Position „2-Kanal“ the cabinet speakers of the jukebox are switched to the left amplifier channel. Both sockets for the external speakers L and R are switched to the right amplifier channel.

If the slide switch of the volume control unit is switched to „2-Kanal“ a separate control of both cabinet speakers and external speakers (e.g. in another room) is possible (left knob for inside, right one for outside). The slide switch „Mono-Stereo“ has to be set to mode „Mono“.

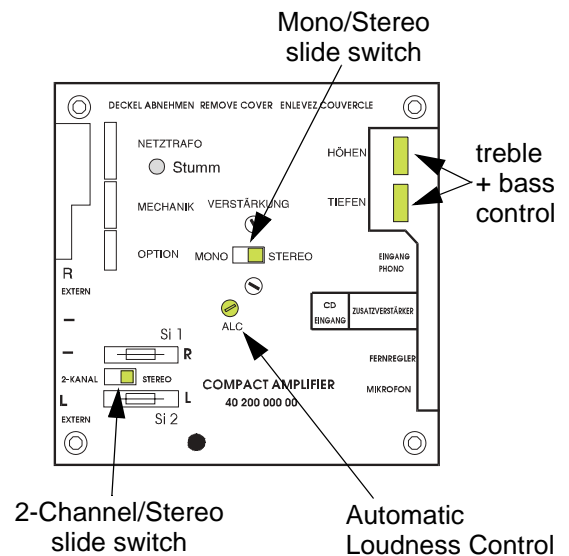

## 12.6 Maximum amplifier load and external speakers

The amplifier may not be loaded with more than 4ohms per channel (less ohms means more load!). If the amplifier is operating in 2-channel mode, the speakers are all loaded to the LH channel. The impedance of all external speakers per channel in Stereo mode should not be less than 8ohms, because the cabinet speakers represent a load of already 8ohms per channel. If the amplifier is working in 2-channel mode, the speakers are all loaded to the LH channel. The RH channel (now switched to the sockets 'R-Extern' and 'L-Extern') now may be loaded with a minimum of 4ohms.

The output to a 4ohms load is 70watts sinus power at 1% distorsion, to 12ohms it is about 24watts, to 24ohms it is about 12watts. That means, that e.g. a 12ohms speaker connected to the external channel at Dual channel operation must be a type of at least 24watts, otherwise the speaker is in danger of destruction at higher volumes. Speaker groups, so-called HiFi boxes, may have, at certain frequencies, impedances much lower than their rating.

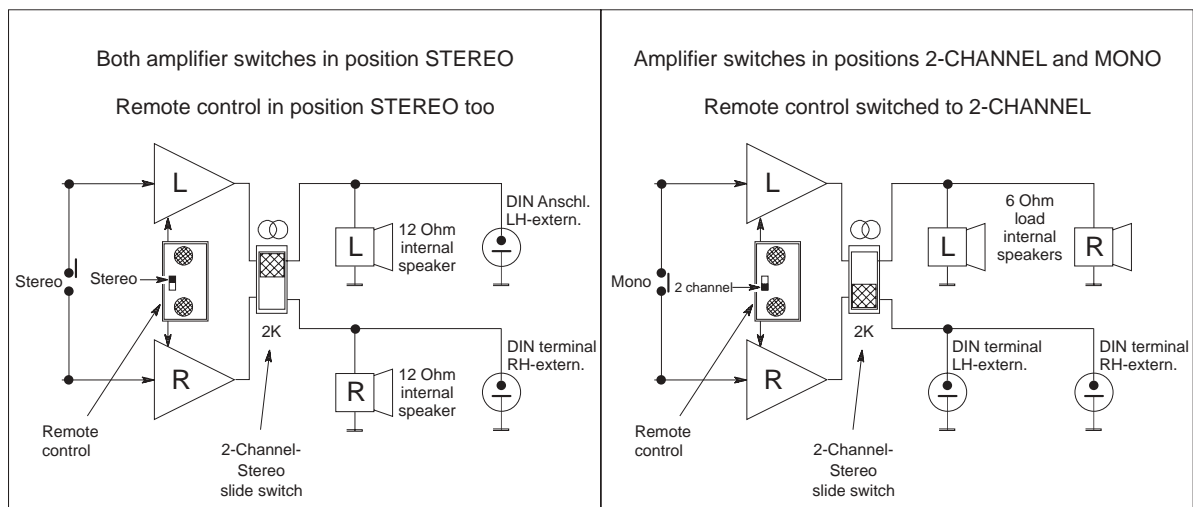

## 12.7 Connection of external speakers

Additional speakers may be connected via two speaker DIN plugs to the amplifier.



**ATTENTION!** In Stereo mode, do not connect a single speaker with less than 8ohms to the amplifier!

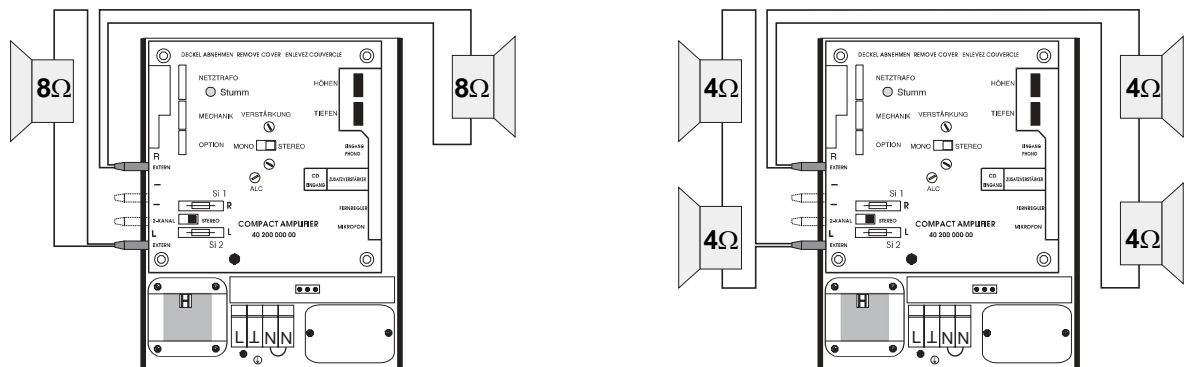

Connection of 2 speakers of 4ohms in series representing a total impedance of 8ohms

## 12.8 Infrared remote control

If required an infrared remote control will be installed at the factory or can be delivered as a conversion kit (part no. 0050917; amplifier I84).

If it is already installed you will find the hand transmitter in the cashbox.

By pressing the buttons 'high' and 'low' at the same time this hand transmitter can be re-programmed. It is then set to work with jukeboxes which have an infrared remote control with selection buttons.

Batteries: 2 micro cells type LR03 (AAA) (will be delivered).

### The meanings of the buttons...

- HIGH
  - Increases the volume. Press the button rapidly to increase the volume quickly.
- LOW
  - Decreases the volume. Press the button rapidly to decrease the volume quickly.
- MUTE
  - As long as this button is pressed the jukebox is muted.
- CANCEL
  - Cancels the playing track. If 'albumplay' is enabled the next track will be played.



**NOTE:** The infrared receiving unit memorizes the last volume value before switch off the jukebox and starts with the same level when switched on again.

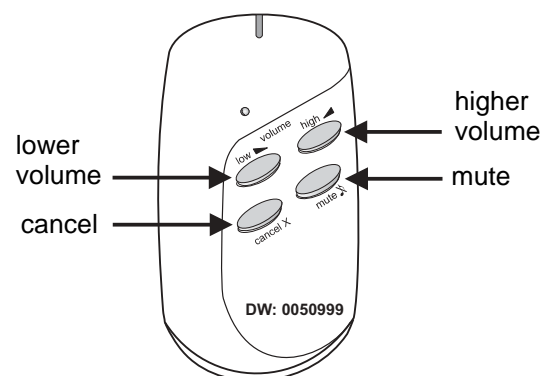
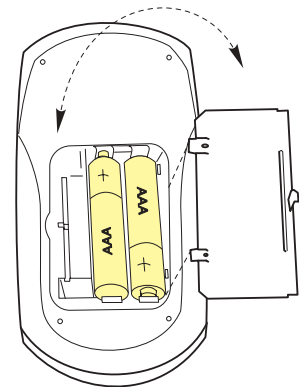

## 12.9 Infrared remote control with selection buttons

If requested an infrared remote control will be installed at the factory or can be delivered as a conversion kit (part no. 0047522; amplifier I84). If it is already installed you can find the remote control in the cashbox. The receiver eye of the infrared remote control is located underneath the keyboard. Beam it directly if possible.

Batteries will be delivered. Two micro cells Typ LR03 (AAA) are needed.

### The meanings of the buttons:

- **BUTTONS 0 - 9 and RESET**
  - If credit is given or free play is programmed a CD can be selected with the buttons 0 to 9 and R.



**NOTE:** Double button functions as required in the service programs (i.e. press button 5 -hold down- and press button R), are not possible. For this you only can use the keypad of the jukebox.

- **OPTION button**
  - This button can be used either as credit button or to switch on and off the continuous play function.
- **HIGH**
  - Increases the volume.
- **LOW**
  - Decreases the volume.

The jukebox saves the actual volume if it is switched off.

- **MUTE**
  - The first button operation switches the sound off. The next operation switches it on ('Toggle-function').
- **CANCEL**
  - Cancels the playing track. If 'albumplay' is enabled the next track will be played.

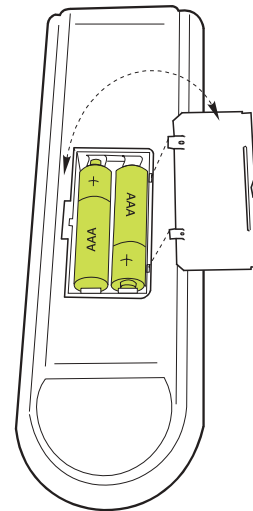
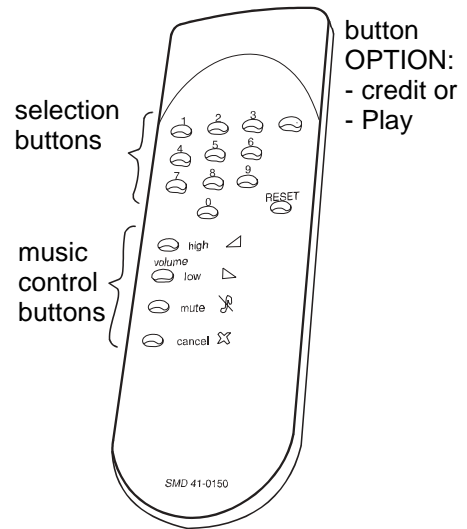

## 13 Function tests

Following checks can be done in service level 1.  
Therefore set ...

1. ... slide switch Service in position ON and ...
2. ... press LT button.  
⇒ Display shows '0 0'.

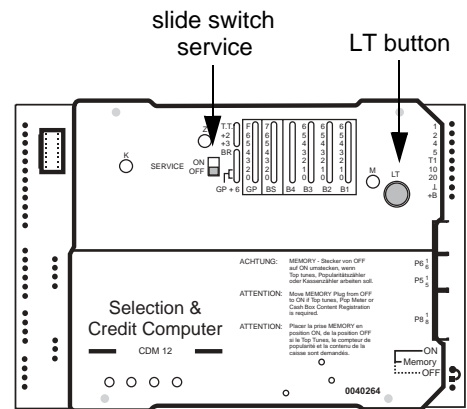

### 13.1 Digital display test / EPROM-version, level 1 button 4

1. Press selection button 4.  
⇒ All segments counting 0 to 9 are displayed, then the program version number (EPROM version), e.g.  
⇒ A = type: 03 - CD1 mechanism, player: CD-PRO  
⇒ B = version number
2. To cancel the procedure press selection button R.

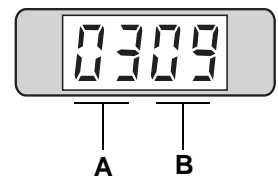

### 13.2 CD carrier control check, level 1, button 8

1. Press selection button 8.  
⇒ Relay M3 on the S&CC pulls in and CD basket turns provided that the gripper arm is in carrier position. The carrier turns as long as selection button 8 is pressed.

### 13.3 Gripper arm motor test, level 1, button 7

1. Press selecton button 7.  
⇒ Relay M operates and a CD under the gripper arm position will be transferred to the CD player. If selection button 7 is pressed during play, the CD will be returned into the carrier after one second.



**ATTENTION!** The gripper arm only moves ewhen the gear switch 'Gripper Motor' is in position ON.

### 13.4 CD player check (START), level 1, button 6

1. Press selection button 7 to place one CD onto the turntable.
2. Press selection button 6.
  - ⇒ The CD will start to play beginning with the first track.
  - ⇒ Display shows first....



TRACK number

3. ... and then the current play time in seconds, e.g. 8sec.
4. If no track is pre-selected with selection button 0 or 9, the complete CD will be played starting track 1.



PLAY TIME of the actual track

### 13.5 Jump to NEXT track, level 1, button 0

1. Press selection button 7 to place one CD onto the turntable.
2. Press selection button 0 (several times).
  - ⇒ The CD starts and the track number according to the number of key actuation will be played. Only this track will be played.
  - ⇒ Display shows first e.g. ...



TRACK number

3. ... then the current play time in seconds 8e.g. 8 sec.)
4. If selection button 0 is pressed again once the next track will be played or...
5. ... if selection button 6 is pressed the remaining tracks of the CD will be played.



PLAY TIME of the actual track

### 13.6 Jump to PREVIOUS track, level 1, button 9

1. Press selection button 7 to place one CD onto the turntable.
2. Press selection button 0 (several times).
3. Press selection button 9, the player jumps to the previous track with each actuation. Reaching track 1, this track will be played continuously.
4. If button 6 is pressed in between after this the remaining tracks of the CD will be played.
5. If track 1 is reached this track will be played continuously.



## 13.7 STOP playing, level 1, button 5

1. Press selection button 5.  
⇒ CD play will be interrupted and display shows:

- To terminate all the tests to return to normal operation, set slide switch Service to OFF and press LT button.



initial position  
service level 1  
mechanism type: CD1  
player type: CD-PRO

# 14 Description of S&CC price setting

**Statement:**

At the RH side of the S&CC unit so-called coin inputs are located designated by the numbers 1, 2 ... 10, 20. These inputs are used to set a memory value to the 'basic unit' the computer uses to figure credits. If no bonus jumpers are inserted and input 1 is shorted to ground by a coin validator, the S&CC unit gives one credit. This corresponds to a basic unit and will be called as one input in the following description. In most applications one input pulse agrees to the lowest coin value. The terminals 2 to 20 give corresponding to their number 2 to 20 input pulses per coin insertion.

If no jumpers are inserted, each input pulse switches the S&CC unit to the next bonus step B1 - B4. This is first of all without result because no jumpers are set in the rows B1 to B4.

If there are jumpers set in B1 to B4 additional credits will be given according to the reached bonus step and the jumper setting in this step.

**Example:**

B1 is set from 0 to 3: By reaching the first bonus step (after one input pulse) one basic credit is given + 3 credits from the bonus step B1 = 4 credits will be displayed.

If the same jumper is set in B2 and the next input pulse reaches the S&CC unit, it will switch to the next bonus step B2 and the credits given before the basic credit from the input pulse and the three credits from B2 will be added 4 + 1 + 3 = 8 credits. This is repeated until B4 is reached.

If the jumper BR is set, the S&CC unit will stay in step B4 until the next selection is made. At each input pulse the basic credit of this pulse and the bonus credits from step B4 will be given. If BR is not set, the S&CC unit will jump back to step B1 when B4 is overflowed.

A jumper in BS causes the computer not stepping at each input pulse to a new bonus step, but moreover when two or up to seven input pulses have reached it. For example, if a jumper in BS is set from 0 to 4, the bonus step B1 will first be reached after 4 input pulses. B2 will be reached after the next 4 pulses.

A jumper in GP means that the computer will not give a basic credit at each input pulse, but will only give a basic credit after the programmed number of credits in GP.

Example: GP: 0 -> 4 = 4 input pulses give one credit. This system is needed to enable the machine to deal with smaller coins as a nickel and to be able to interface with foreign coin systems.

The table below gives an example for the following jumper setting:

BR = bonus reset

BS = bonus step

GP = basic price

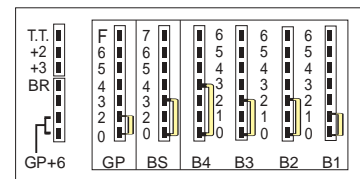

pulse	1.	2.	3.	4.	5.	6.	7.	8.	9.	10.	11.
credits GP	-	1	-	1	-	1	-	1	-	1	-
bonus step			B1			B2			B3		
credits BS			1			2			2		
sum	-	1	2	3	3	6	6	7	9	10	10

pulse	12.	13.	14.	15.	16.	17.	18.	19.	20.	21.	22.
credits GP	1	-	1	-	1	-	1	-	1	-	1
bonus step	B4			B1			B2			B3	
credits BS	3			1			2			2	
sum	14	14	15	16	17	17	20	20	21	23	24

# 15 Integrated test program of the CD-PRO player

## 15.1 Access to the player functions without S&CC unit

For a test the complete player unit CD-PRO can be operated without S&CC unit.

The power supply from the installed amplifier, the sub-transformer and an amplifier with CD input for the audio signal is required.

A one digit digital display indicates the current operation mode and three command buttons are located on the player chassis.

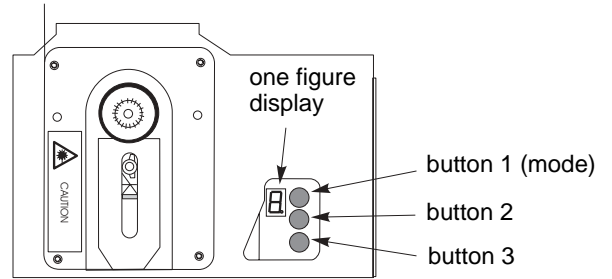

The one digit display is able to display more information.

To display two or more digits the information starts with a dark phase of approx. 1 sec. followed by the digits shown one after another with dark phase of 100 msec. between each digit. The most significant digit will be displayed at first.

After power on and after a general reset command (display shows "8"), the program version number of the Deutsche Wurlitzer GmbH CD control unit will be displayed with four digits followed by the version number of the CD-PRO servo processor with two digits.

If the player is in stand by and the three buttons on the player are pressed at the same time the above mentioned sequence will be displayed but without showing "8" for "reset active".

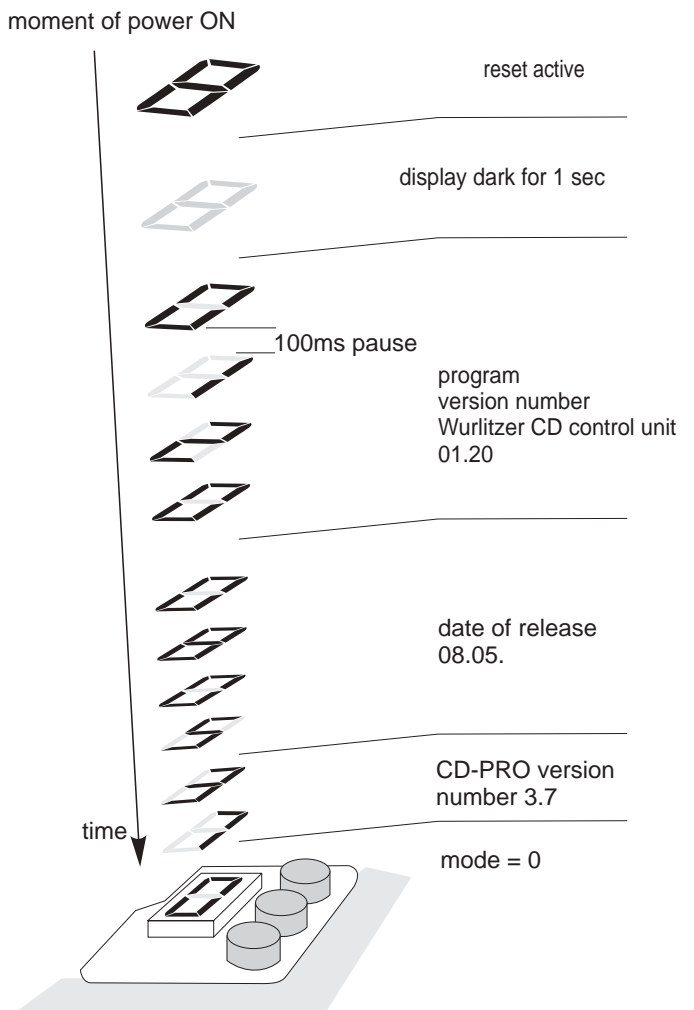

## 15.2 Test functions CD-PRO

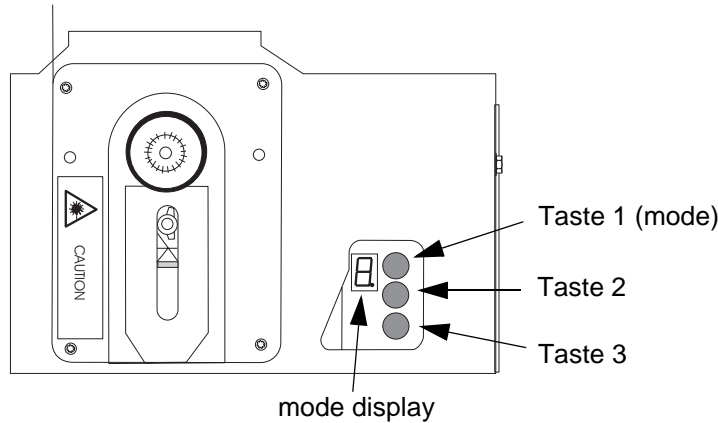

mode display	button 1 (mode)	button 2	button 3	buttons 2 + 3 together
0	mode 1	start	stop	repeat CD
1	mode 2	next track	previous track	repeat track
2	mode 3	search forward	search backward	single, double speed
3	mode 4	pause ON	pause OFF	
4	mode 5	volume +	volume -	mute
5	mode 0	track + 1	track - 1	play selected track (read TOC, if necessary)

If “repeat CD” had been selected with the buttons 2 + 3 in mode 0 the display will be “99”. At each beginning of a new track it will be displayed with two digits.

If “repeat track” had been selected with the buttons 2 + 3 in mode 1 the actual played track will be displayed.

By pressing of two buttons at the same time additional values will be displayed:

- Buttons 1+2:
  - The last occurred error code will be displayed (ref. to error code table). This error code will be reset after this retrieval or after a CD-PRO reset (e.g. the next power on).
- Buttons 1+3:
  - The actual playing track will be displayed.
- Buttons 1+2+3:
  - No CD is playing: Program version and date of release.
  - CD is playing: Max. / min. track number will be displayed.

Error code	Meaning
0	No error
2	Focus error or no disc
7	Subcode error, no valid subcode
8	TOC error
10	Radial error
12	Fatal sledge error
13	Turntable motor error
31	Search time out
32	Search binary error
33	Search index error
34	Search time error
40	Illegal command
41	Illegal value
42	Illegal time value
43	Communication error
44	Reserved
45	HF detector error
48	Emergency stop



**NOTE:** If commands will be sent to the CD-PRO player, the display will flash. During this time no commands given by the buttons will be accepted. While the table of contents (TOC) is read an 8 flashes in the display. In this way, the necessary time to read the TOC can be prolonged. So bad CDs can be recognised and taken out.

### 15.3 Special test functions of the CD-PRO player

Service program of CD-PRO (mode 9). With this service program different functions of the CD-PRO player can be tested.

**How to call:**

Switch main power OFF. Press button 1 - hold down - and switch main power on. (Remark: "Power ON - OFF" can also be done by disconnecting the wire bk./gy. from pin 6 of the sub transformer.)

**Function:**

The CD control unit steps into mode 9 and runs the tests 90 up to 99. Mode 9 will be displayed continuously. While changing the test step it will be displayed with two digits

**Remarks:**

For starting test step 94 a CD has to be placed on turntable.

- The button 1... has no function during this test.
- The button 2... switches to the next test step.
- The button 3... switches to the previous test step.

**Quit:**

Press button 2 while test 98 is running. Control unit steps over test 99 to mode 0 automatically.

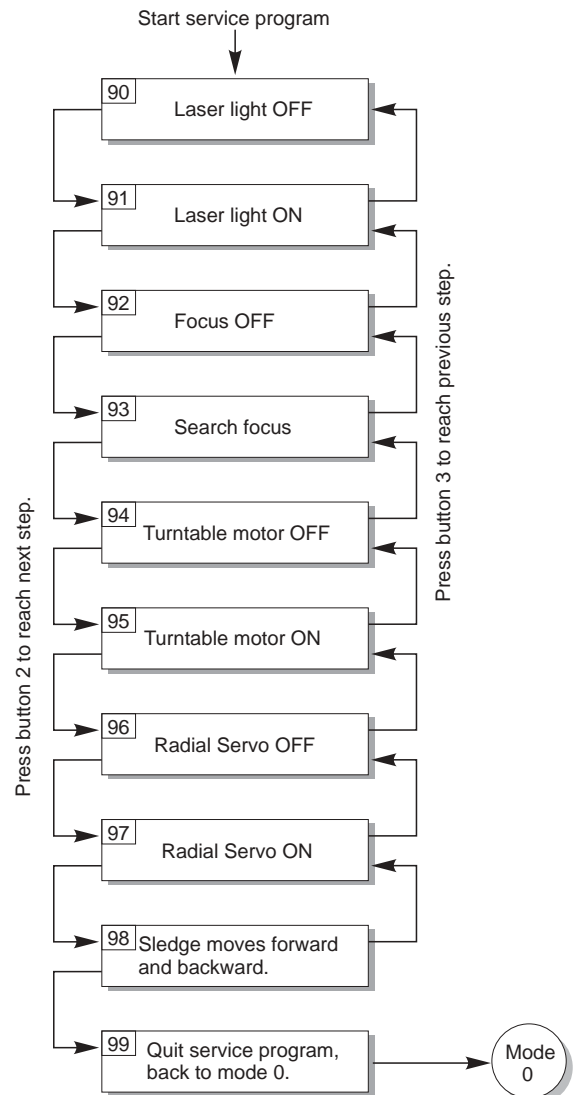

FIELD SERVICE MANUAL

**Test 91:** You can check the laserlight with an infrared indicator.

**Test 93:** Without a CD: laser lense moves up and down. If you put a CD on the turntable while the test runs the lens stops moving if it finds the focus point.

**Test 95:** The turntable motor must spin.

**Test 98:** The sledge moves itself from inside to outside and back again. If this test is successful the speed of the disc must change to lower speed at the outside of the disc.

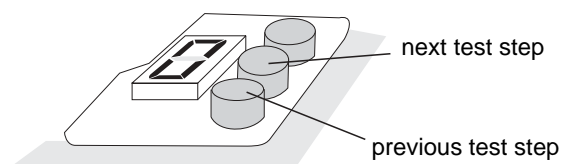

## 16 Functional description of the mechanism

### 16.1 Abbreviations

<b>CD sub transformer</b>	Insulating transformer with primary 30v AC / secondary 9v AC and 14v AC for laser control board.
<b>CD-PRO SC control board</b>	The CD-PRO SC is controlled by the S&CC and commands the operating sequence of the CD player. All commands are verified and carried out by the on-board micro processor. CD-PRO SC also supplies the voltages for the laser control board.
<b>Laser control board</b>	Control board and interface for CD player. This assembly is controlled by a serial data connection, the easy-line bus. Supply voltages are also provided by this bus.

### 16.2 Functional description

#### 16.2.1 Power supply

Power is supplied from the amplifier to the mechanism chassis over plug 'mechanism'. The CD carrier latch solenoid M3 is connected to -30v DC. The gripper motor MM operates with +30v DC and the CD carrier motor KM with 30v AC.

#### 16.2.2 S&CC supply

Looped over the mechanism chassis the S&CC unit is supplied by the amplifier with 30v AC and 12v DC over plug red. 12v DC are protected by fuse Si5 and the 30v AC are protected by fuse Si6 on the amplifier board.

#### 16.2.3 CD-PRO supply

The CD-PRO SC board, the laser control board and connected CD player are supplied by the CD sub transformer. The sub transformer is supplied with 30v AC. A thermostatic switch inside the transformer protects this circuit.

Secondary supply is 9v AC (for the digital part of the CD-PRO SC) and 14v AC for the supply of the laser control board. All voltages are rectified and stabilised on the CD-PRO SC.

The power supply for the RS232 level adaptor (MAX232) is isolated from the other circuitry. It belongs to machine ground.

The CPU and the laser control board are connected to the audio ground. The player is connected with a serial data link from the S&CC plug ST5 to the CD-PRO SC board running the 'DW-Protokoll-CD' and from there via optocouplers over the DSA bus (blue cable).

#### 16.2.4 Digital display

The digital display consists of four 7-segments digits multiplex from the S&CC. The 2 LH digits show the CD and the RH digits the title.

Example: CD 18, track 01

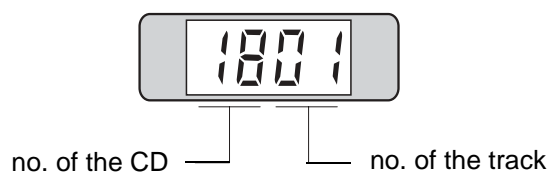

**16.2.5 Number of plays and cash counter**

The S&CC unit acknowledges coin insertion by indicating the number of selectable plays and a series of relay pulses (relay C). The plays are established depending on the setting of the bonus jumpers in the rows B1 to B4 on the S&CC. A mechanical counter connected to plug green pin 3 (connects to ground) and +30v registers the coins inserted in basic units. The mechanical counter is optional.

**16.2.6 Selection and CD carrier**

After a valid selection the S&CC operates the M3 relay, connecting plug blue pin 4 to ground. CD carrier latch solenoid M3 pulls in and starts carrier motor KM by microswitch m3. The CD carrier turns to the selected position.

**16.2.7 Start / counting process**

The CD carrier is provided with tooth slots at each CD compartment. By means of a light gate in front of the carrier the exact slot position is controlled. The tooth slots of each compartment are registered by the S&CC and visible by the flashing Z-LED when the carrier rotates. Just before passing the 01 position the K-LED will flash indicating CD 1. Slot 01 is found by passing of a special bracket mounted underneath the carrier base plate. The teeth (Z-LED) are counted after the K pulse has been sent.

**16.2.8 CD transfer**

If the desired CD has reached the gripper arm position, M3 is de-energized and the CD carrier stops. To transfer the CD the S&CC starts the gripper arm motor MM over plug blue pin 2 from relay M. At the same time a 'Reset' command is transferred to the CD control unit which resets the CD-PRO SC control board and laser control board. The gripper arm now transfers the CD to the player. The relay M is active for 1.5seconds. During this time the gear motor has turned and K6 (slide contact on the gear box contact disc) switches the motor into self holding position. After the CD is placed onto the turntable and held by the magnetic clamp arm, K1 opens, ground is disconnected from the gear motor MM and it stops. K6 is closed.

**16.2.9 Mute off**

The amplifier is now activated from the open K1 contact by the mute or cancel line grey over plug mechanism. D1 prevents continuous mute from the S&CC.

**16.2.10 Play**

During the 6 seconds lasting transfer operation the S&CC sends the selection information to the CD-PRO SC which is carried out by the laser control board. The CD starts after approx. 2 seconds. The audio frequency signal is connected with RCA jacks to the amplifier CD-input.

At the end of the track the CD control is switched to pause mode. This is transferred over the communication line to the S&CC which recognises this condition which then causes a stop-title-command. The CD stops.

**16.2.11 Cancel**

3 seconds after the start of a play a track can be interrupted with the cancel button.

The S&CC recognises this over plug green/pin 1. Diode 2 in the mechanism chassis prevents restart of the gripper motor by pulling the input to ground. Otherwise the gripper mechanism would pull the CD from the still spinning player. The control immediately sends a stop command through the 'DW-Protokoll-CD' to the CD-PRO SC for stopping the CD. A serial acknowledgement informs the S&CC.

**16.2.12 CD return**

The mechanism MM is being activated from the S&CC for 1.5 seconds. The gear box contact disc brings K6 into self-latching (K1 is closed = ground). When K6 reaches the insulated gap the gripper motor MM stops. The gripper arm has returned the CD. K7 and K8 are closed again. The closed K7 reports over the circuit around M3 (-30v DC over wire grey plug blue/pin 4 (relay M3 open) to T22 in the S&CC): 'CD in carrier'. The closed K8 allows a new CD search.

**16.2.13 New selection**

If another selection has been registered in the S&CC the sequence is repeated from the beginning.

**17 Error messages and remedy****Error**

- No operation, lamps and display are dark.
- No operation, only the display is dark.
- Coins are badly or not accepted.
- Coins are accepted but no credit (plays) on display.
- Display is flashing after a selection.
- After a selection the carrier turns and stops.
- After a selection the carrier turns constantly.
- Some CDs are not playing.
- No sound.
- Sound from one channel only.

**Possible reason and remedy**

- Powerline interrupted.
- Power switch is in OFF position.
- Check main fuse (3.15/6A) at the amplifier.
- Amplifier K99: check fuse F4
- Amplifier F91: check fuses Si 102 and Si 103
- Amplifier I84: check fuse Si5
- Check transformer plug from amplifier to the S&CC
- Jammed coins in the validator.
- Coin acceptor needs to be cleaned.
- Return lever mechanism jammed.
- Check plugs at RH side of the SCC unit.
- Check if the slide switch on the SCC unit is in position service OFF.
- Not enough money inserted.
- Number of CDs in the magazine is programmed incorrectly (see [chapt. 2.3, on page 9](#))
- Amplifier K99: check fuse F1
- Amplifier F91: check fuse Si 101
- Amplifier I84: check fuse Si6
- Set the switch 'gripper arm' on the chassis to ON position.
- Faulty lamp in the carrier light gate.
- Plug 'Black' at the SCC unit in reverse position.
- CDs in the magazine are in reverse position.
- CDs need to be cleaned.
- Amplifier K99: turn volume control at the rear side of the jukebox clockwise. Check fuses F2 and F3
- Amplifier F91: press button '+' at the rear side of the jukebox
- Amplifier I84: turn volume control at the rear side of the jukebox clockwise. Check fuses Si1 and Si2
- Check the loudspeaker plugs at the amplifier.
- Check the cable from the CD player to the amplifier.
- K99 amplifier: set the slide switch on the volume remote control in position stereo



## 17.1 Failures with illumination, display and power system generally

Symptom	Cause	Possible faults
<ul style="list-style-type: none"> <li>No light, jukebox not working at all</li> </ul>	<ul style="list-style-type: none"> <li>No power at wall socket; open primary circuit</li> </ul>	<ul style="list-style-type: none"> <li>Wall socket defective. Main fuse blown</li> <li>Mains fuse of the amplifier blown</li> <li>Internal break in line cord or plug</li> <li>Line switch off or defective</li> </ul>
<ul style="list-style-type: none"> <li>Illumination does not light, but jukebox works</li> </ul>	<ul style="list-style-type: none"> <li>Defective lamp circuit</li> </ul>	<ul style="list-style-type: none"> <li>Lamp circuit plug not in light socket at amplifier</li> <li>Lamp not properly seated in holder</li> <li>Defective starter, defective lamp</li> </ul>
<ul style="list-style-type: none"> <li>Bubble tubes do not work</li> <li>Colour tubes do not rotate</li> <li>Lamp 24v does not light</li> </ul>	<ul style="list-style-type: none"> <li>Defective 24v circuit</li> </ul>	<ul style="list-style-type: none"> <li>Power supply leading from transformer to distribution interface interrupted</li> <li>Fuses on interface (1A/M) defective</li> <li>CAUTION! Short circuit in harness of heating resistors possible</li> </ul>
<ul style="list-style-type: none"> <li>Digital display remains dark, but jukebox works</li> </ul>	<ul style="list-style-type: none"> <li>Signal supply leading to display interrupted</li> </ul>	<ul style="list-style-type: none"> <li>14pole D.I.L. plug not set or wrong way round (correct: flat cable is coming from LH side, orange below)</li> </ul>
<ul style="list-style-type: none"> <li>Digital display shows nonsense figures, but jukebox works</li> </ul>	<ul style="list-style-type: none"> <li>Signal lines interchanged</li> </ul>	<ul style="list-style-type: none"> <li>14pole D.I.L. plug displaced (not in line with the base)</li> <li>Computer defective, e.g. IC7</li> </ul>
<ul style="list-style-type: none"> <li>Digital display shows incomplete figures (missing segments)</li> <li>The fault is the same with all four digits</li> </ul>	<ul style="list-style-type: none"> <li>Signal for one (or some) segments missing</li> </ul>	<ul style="list-style-type: none"> <li>One pin (or some) of 14pole plug broken off</li> <li>One wire (or some) of flat cable broken</li> <li>Broken connection at display PC-board</li> <li>Computer defective, e.g. IC7</li> </ul>
<ul style="list-style-type: none"> <li>Digital display shows incomplete figures (missing segments)</li> <li>The fault, however, occurs with one (or up to three) of the four digits only</li> </ul>	<ul style="list-style-type: none"> <li>Segment signal does not reach this digit</li> </ul>	<ul style="list-style-type: none"> <li>Cracked connection on display PC-board</li> <li>Defective display unit (4 identical one-digit units)</li> </ul>
<ul style="list-style-type: none"> <li>One of the digits of display completely off</li> </ul>	<ul style="list-style-type: none"> <li>Multiplex signal missing</li> </ul>	<ul style="list-style-type: none"> <li>Defective D.I.L. plug or broken wire (A1, A2, A3, A4)</li> <li>Display or computer defective (T23 - T26)</li> </ul>

## 17.2 Faults with the coin system

The jukebox, however, operates normally with free credit established with the jumper in the row GP at the S&CC unit (0 - F)

The function of the coin system can be checked by observing the LED M on the computer, which should light up with every coin accepted. Credits can also be given with the credit button on the interface of the electronic coin acceptor (ECA). If a mechanical coin acceptor is installed, then with the credit button next to the coin acceptor.

Symptom	Cause	Possible faults
<ul style="list-style-type: none"> <li>Coins rejected</li> </ul>	<ul style="list-style-type: none"> <li>Disabled coin acceptor</li> <li>No power supply (ECA)</li> </ul>	<ul style="list-style-type: none"> <li>Dirt, oil or dust particle in the coin acceptor</li> <li>coin acceptor maladjusted</li> <li>Reject lever jammed holding the coin acceptor open</li> <li>Coin acceptor or entire jukebox not leveled</li> <li>Interruption in harness from S&amp;CC unit over coin acceptor interface to ECA</li> <li>Interface defective</li> </ul>
<ul style="list-style-type: none"> <li>Single coins give wrong credits (or none at all)</li> </ul>	<ul style="list-style-type: none"> <li>Coin actuates the wrong coin switch</li> <li>Coin pulse does not reach the computer</li> <li>ECA defective</li> </ul>	<ul style="list-style-type: none"> <li>Coin acceptor not properly positioned, leads the coin to an improper switch paddle or by passing it</li> <li>One line of the coin switches to computer cable broken, disconnected at either end or wrongly set at computer connector</li> <li>For ECA: switching transistor at the interface defective</li> </ul>
<ul style="list-style-type: none"> <li>Permanent credit</li> <li>Display shows permanently '1'</li> <li>Credit free selections</li> </ul>	<ul style="list-style-type: none"> <li>Jumper is set from 0 to F in row GP (free play)</li> </ul>	<ul style="list-style-type: none"> <li></li> </ul>
<ul style="list-style-type: none"> <li>Wrong credits, repetitive or all the time, with credits higher or lower than programmed pricing</li> </ul>	<ul style="list-style-type: none"> <li>Programming mistake</li> </ul>	<ul style="list-style-type: none"> <li>Jumper BR is not set, then reset to bonus level 1 (B1) if bonus level 4 is overstepped</li> <li>Unintentional programming in happyHour programming level</li> <li>Programming jumper making poor contact (Note: modifications in reposition of jumpers are only effective by switch off or pressing the LT button)</li> </ul>
<ul style="list-style-type: none"> <li>No credit, coins are properly accepted</li> <li>Free play, with GP-jumper 0 - F still possible</li> </ul>	<ul style="list-style-type: none"> <li>All coin input lines disabled</li> <li>Credit inputs inactive (LED M does not light up)</li> <li>Checking of single inputs (1, 2, 4, 5, T1, 10, 20) with a ground connected test wire</li> </ul>	<ul style="list-style-type: none"> <li>30v AC does not reach the computer (from amplifier to CD mechanism to plug red/pin 1 at the S&amp;CC)</li> <li>Computer defective (D7, LED M)</li> </ul>
<ul style="list-style-type: none"> <li>No credit although coins are registered (LED M lights up)</li> <li>Even no free play credit with GP jumper set from 0 to F</li> </ul>	<ul style="list-style-type: none"> <li>Computer out of operation</li> </ul>	<ul style="list-style-type: none"> <li>No 12v power supplied to the computer (pin 2 and 4 plug red)</li> <li>Computer defective</li> </ul>

- No credit, LED M is lit permanently
- Permanent contact to ground of one or more coin inputs
- Ground connection of several coin input leads (check by disconnecting the leads at the S&CC coin inputs)
- Defective transistor at the ECA interface (if existing)
- Partially defective transistor may cause free credit
- Function check with ground connections to several coin inputs of the S&CC

## 17.3 Faults by selection entry

### (Credit system does work)

Symptom	Cause	Possible faults
<ul style="list-style-type: none"> <li>• No selections</li> <li>• Selection is displayed flashingly</li> </ul>	<ul style="list-style-type: none"> <li>• Selection is not accepted</li> </ul>	<ul style="list-style-type: none"> <li>• No credit available (CAUTION! After free play setting LT button has to be pressed)</li> <li>• The entered selection is higher than the programmed number of CDs</li> <li>• The selected CD is programmed for BGM only</li> <li>• The selected CD is disabled</li> </ul>
<ul style="list-style-type: none"> <li>• No selections</li> <li>• Numbers of actuated keys not displayed (only credit is shown)</li> </ul>	<ul style="list-style-type: none"> <li>• Open circuits in the keyboard wiring</li> </ul>	<ul style="list-style-type: none"> <li>• Plug yellow displaced or not inserted deep enough</li> <li>• Key Reset permanently closed or shorted to ground (pole 12, brown, plug yellow)</li> <li>• Computer defective</li> </ul>
<ul style="list-style-type: none"> <li>• No selections</li> <li>• In standby the LH digit of display shows a number, but selection keys are disabled</li> <li>• With insertion of further coins the new credit is displayed properly</li> </ul>	<ul style="list-style-type: none"> <li>• Permanent selection signal from that key which the number is displayed</li> </ul>	<ul style="list-style-type: none"> <li>• Jammed key, permanently closed key contact</li> <li>• Wire of this contact is shorted to ground</li> <li>• Computer defective (C60 - C70, D44 - D66 possibility of ground shorting, IC8, IC9)</li> <li>• Check with digital multimeter: plug yellow pin2 to 12 approx. 5v DC</li> <li>• Function check with test wire to ground</li> </ul>
<ul style="list-style-type: none"> <li>• No response from one key</li> </ul>	<ul style="list-style-type: none"> <li>• Open circuit with this key</li> </ul>	<ul style="list-style-type: none"> <li>• Malfunction of key contact</li> <li>• Insufficient key travel</li> <li>• Broken wire on this key</li> <li>• Plug yellow not seated good enough</li> <li>• Computer defective with an affected input circuit (R65 to 86, D45 to 65, IC8, IC9)</li> </ul>
<ul style="list-style-type: none"> <li>• The CD played is not the one selected</li> <li>• The selection was properly displayed</li> </ul>	<ul style="list-style-type: none"> <li>• Improper counting of CD carrier position</li> </ul>	<ul style="list-style-type: none"> <li>• Wrong adjustment of light control gates</li> <li>• Illumination light affecting Z light gate, reflections at the edges of carrier base plate</li> <li>• Record carrier latch delayed by mechanical friction or too wide opening (latching too late)</li> <li>• Light control gate retarded</li> </ul>
<ul style="list-style-type: none"> <li>• After power on one track or more are played without selection</li> </ul>	<ul style="list-style-type: none"> <li>• There are selections left in the memory</li> </ul>	<ul style="list-style-type: none"> <li>• Credit and selection reset after power off not used</li> </ul>

Faults by selection entry

- The CD played is the one selected, however, not the selected track
- Selection does not correspond to the label
- Laser control board defective
- The selected track number is higher than the number of tracks on CD.
- After reaching the highest track number, the laser control board starts to count from the beginning again
- The selected CD is not played
- Counting pulse Z or sensing pulse K missing
- lamp of light agte dark
- Break in harness to plug BLACK
- S&CC defective (IC10, C75 - C78, D92, D94)
- The CD carrier is rotating permanently
- The S&CC gets the impression that a CD is still playing
- Caused by a defective or maladjusted K7 switch the voltage 30v DC at pin 4 plug GREY is missing
- This voltage usually indicates the replacing of a CD in carrier after playing
- If this circuit is interrupted the status of S&CC is the same as CD is playing, so it is not able to start the carrier for a new search
- S&CC defective (T22)
- (Program version 3.09 does not take back a CD after a fault occurs)
- Digital display shows the selection correctly, but after this the jukebox does not operate
- The selected CD is placed onto the turntable, but will not be played
- The digit on the CD control does not light
- After approx. 50 seconds CD will be returned to carrier
- The selected CD is placed onto the turntable, but will not be played
- The digit on the CD control shows '0'
- After approx. 50 seconds CD will be returned to carrier
- The selected CD is placed onto the turntable, but will not be played, but after approx. 50 seconds CD will be returned to carrier
- Failure between DW-CD control and laser control board and player
- Leads not deep enough inserted between player, laser control board or DW-CD control
- Player or laser control board defective
- 30v AC supply for CD control and player missing
- Fuse blown
- Interrupts in lines from amplifier to S&CC or from there to CD controller
- Sub transformer switched off by its thermostatic switch
- Sub transformer defective
- Voltage control ICs on CD-PRO SC faulty
- Communication between S&CC P5 and CD control interrupted
- Data leads between S&CC and CD controller interrupted
- (In this case operation is possible in mode 0 button T2, stop with T3)

## 17.4 Repetitive apply of selected or non-selected CDs to turntable

Symptom	Cause	Possible faults
<ul style="list-style-type: none"> <li>• Permanent gripper arm movement (with or without CD) with the CD carrier not turning in between</li> <li>• This continues even if plug BLUE is disconnected at the S&amp;CC</li> <li>• Permanently gripper arm movement</li> <li>• Discontinued after plug BLUE is pulled off at the S&amp;CC</li> </ul>	<ul style="list-style-type: none"> <li>• Main cam motor MM not stopping at the end of the play cycle</li> <li>• Computer running out of program</li> </ul>	<ul style="list-style-type: none"> <li>• Wiper switch K6 maladjusted</li> <li>• Computer out of program routine (cut power to S&amp;CC for a second to initiate a restart of program)</li> <li>• Computer defective (relay 2, T2 or T22)</li> <li>• Microswitch K7 or carrier latch solenoid M3 defective</li> </ul>

## 17.5 Failures in the system carrier - gripper arm

Symptom	Cause	Possible faults
<ul style="list-style-type: none"> <li>• Record carrier permanently rotating, even after plug BLUE is pulled off</li> <li>• If a selection is made the gripper arm randomly takes a CD onto the turntable</li> <li>• Record carrier permanently rotating</li> <li>• Sometimes the gripper arm randomly takes a CD onto the turntable, but the CD will not be played</li> <li>• Also by pressing LT button the gripper arm takes a CD onto the turntable, the CD will not be played</li> <li>• After power off for a short time a flashing 8 will appear in addition on the display</li> </ul>	<ul style="list-style-type: none"> <li>• Carrier latch permanently open</li> <li>• Carrier latch solenoid permanently switched on</li> </ul>	<ul style="list-style-type: none"> <li>• Carrier latch or its solenoid jammed</li> <li>• Grey line from M3 to pole 4 of plug BLUE shorted to ground</li> <li>• S&amp;CC defective (relay 4 sticks, T4 defective)</li> </ul>

Failures in the system carrier - gripper arm

- Carrier does not start after a properly completed selection
- Carrier latch does not open
- Circuit of the carrier latch solenoid not completed
- DC supply -30v missing
- Coil of latch solenoid open
- Grey line from M3 to pole 4 or green line to pole 1 (relay common), plug BLUE interrupted
- Computer defective (go to service program to check relay 4 (M3))
- Test only successful if -30v DC voltage across the M3 coil reached pin 4 X4 of the S&CC (plug BLUE)
- Test the machine with a programming jumper from pin 1 green to pin 4 grey
- CD carrier does not rotate although the carrier latch opens after a selection
- Carrier motor KM disabled
- Microswitch M3 (at carrier latch) maladjusted or defective
- Microswitch K8 (at gripper arm) maladjusted or gripper arm not fully in rest position
- Defective motor KM
- Broken wiring
- Gripper arm does not move to take the CD out of the carrier although the selected CD was properly brought forward
- Main cam motor MM does not work
- Motor MM defective
- Pre resistor R15 interrupted
- DC 30v supply missing
- Blue wire to motor broken
- Shortage in capacitor C5 or in motor itself (then R15 hot)
- After approx. 1 second relay M drops out
- Test: connect plug BLUE (green) with pin 2 (blue) with jumper wire of S&CC, if motor is moving then S&CC is defective (relay 2, T2)
- Test also with service program
- The jukebox does not work and takes no notice of any input
- Main cam motor not resting when system in play position
- Wiper switch K1 does not open
- Cancel button at amplifier jammed in 'cancel' position, same with cancel button of the remote control
- Shorted remote control cable
- Retarding resistor R10 at motor MM open
- CD on turntable returned to carrier before play has started

## 17.6 Failures with sound reproduction

Symptom	Cause	Possible faults
<ul style="list-style-type: none"> <li>• Clicks and banging noises during CD playing</li> <li>• Jump over of traces</li> </ul>	<ul style="list-style-type: none"> <li>• Reading of CD data disturbed</li> </ul>	<ul style="list-style-type: none"> <li>• CD defective (error correction for insignificant defects only)</li> <li>• Dirty optic caused by nicotine and/or dust particle</li> <li>• Maladjusted optic assembly</li> <li>• Faults in CD player or laser control board</li> </ul>
<ul style="list-style-type: none"> <li>• CD moves but no sound</li> </ul>	<ul style="list-style-type: none"> <li>• Faults in the system of CD controller - amplifier - speaker</li> </ul>	<ul style="list-style-type: none"> <li>• Audio frequency cable at CD controller or amplifier (chinch socket) not inserted</li> <li>• Audio cable is inserted in the Phono input of amplifier, not in CD input</li> <li>• Speaker fuses blown</li> <li>• Wire grey (pin 8) amplifier to mechanic shorted to ground</li> <li>• Amplifier defective</li> <li>• Laser control board defective</li> </ul>
<ul style="list-style-type: none"> <li>• Hum in sound reproduction</li> </ul>	<ul style="list-style-type: none"> <li>• Ground loop</li> <li>• Amplifier or CD controller defective</li> </ul>	<ul style="list-style-type: none"> <li>• Gripper arm touches the chassis of the player in play position</li> <li>• Other connections between player ground and chassis ground</li> <li>• Ground loop out of the jukebox caused by additional equipment</li> <li>• Amplifier or CD controller defective</li> </ul>

## 17.7 CD not properly returned to carrier

Symptom	Cause	Possible faults
<ul style="list-style-type: none"> <li>• Gripper arm does not move to return the CD into the carrier</li> </ul>	<ul style="list-style-type: none"> <li>• Main cam motor does not start</li> </ul>	<ul style="list-style-type: none"> <li>• Error at motor MM could have developed while a CD was playing</li> </ul>
<ul style="list-style-type: none"> <li>• Returned CD not properly unclamped (not freed) in the carrier</li> </ul>	<ul style="list-style-type: none"> <li>• Main cam motor switched off too early</li> </ul>	<ul style="list-style-type: none"> <li>• Wiper switch K6 wrongly adjusted</li> </ul>
<ul style="list-style-type: none"> <li>• CD missing in compartment is found in other compartment or somewhere about the chassis</li> </ul>	<ul style="list-style-type: none"> <li>• Gripper arm generally moving too fast (time for one complete cam rotation is 11 to 13 seconds)</li> </ul>	<ul style="list-style-type: none"> <li>• Disadjustment of gripper arm</li> <li>• Gripper arm sticks to the centering disc (CD holder arm)</li> <li>• Wrong adjustment of puck arm height</li> <li>• Cam motor too fast</li> </ul>

## 18 Accessories

### 18.1 Microfone kit (part no. 0006953)

This unit enables the use of the jukebox as a paging system, when playing as well as during idling periods. If the paging microphone is switched on while the jukebox is playing, the music will be muted for this period. This kit is to be connected at the microphone socket of the amplifier. The length of the cable between mike pre-amp and the jukebox is approx. 45 ft / 15 m.



### 18.2 BGM-Connector

This equipment offers two features:

1. The sound of an external source (300mV - 1V), e.g. radio or tape, will be reproduced over the speakers of the jukebox with adjustable volume. A selection over the jukebox will mute this source, and it returns only after all selections have been played. (Time-lag can be adjusted).
2. Connecting the jukebox to an existing background system (amplifier), the sound of this equipment is switched off as long as the jukebox is playing. The hook-up for this adapter is the same as the microphone.

BGM connector kit part no.:  
 Amplifier K99 and F91: 0048130  
 Amplifier I84: 0035579

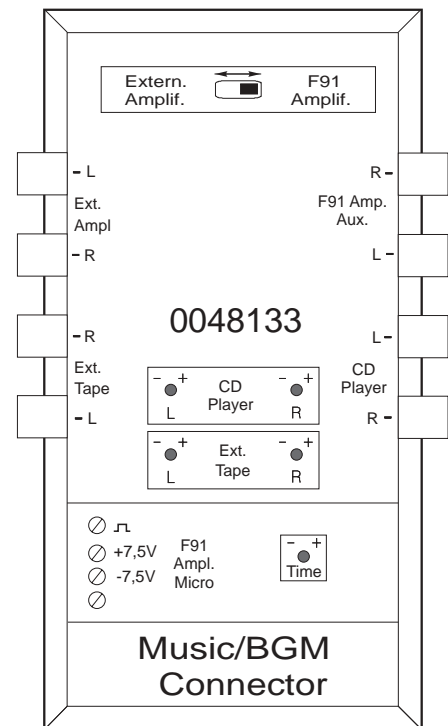





# 19.2 Connection diagram OMT CD

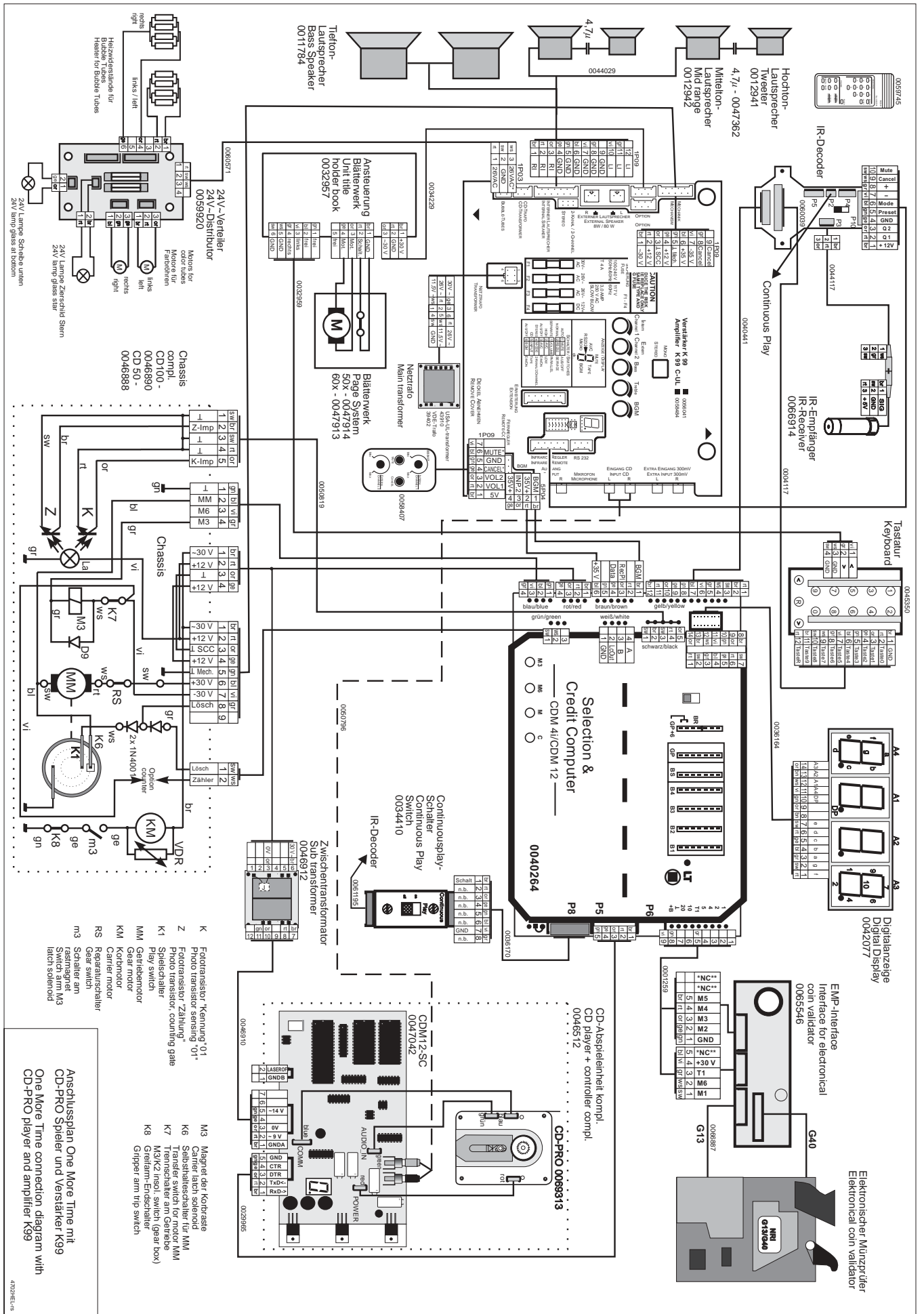

### 19.3 Board layout Selection & Credit Computer

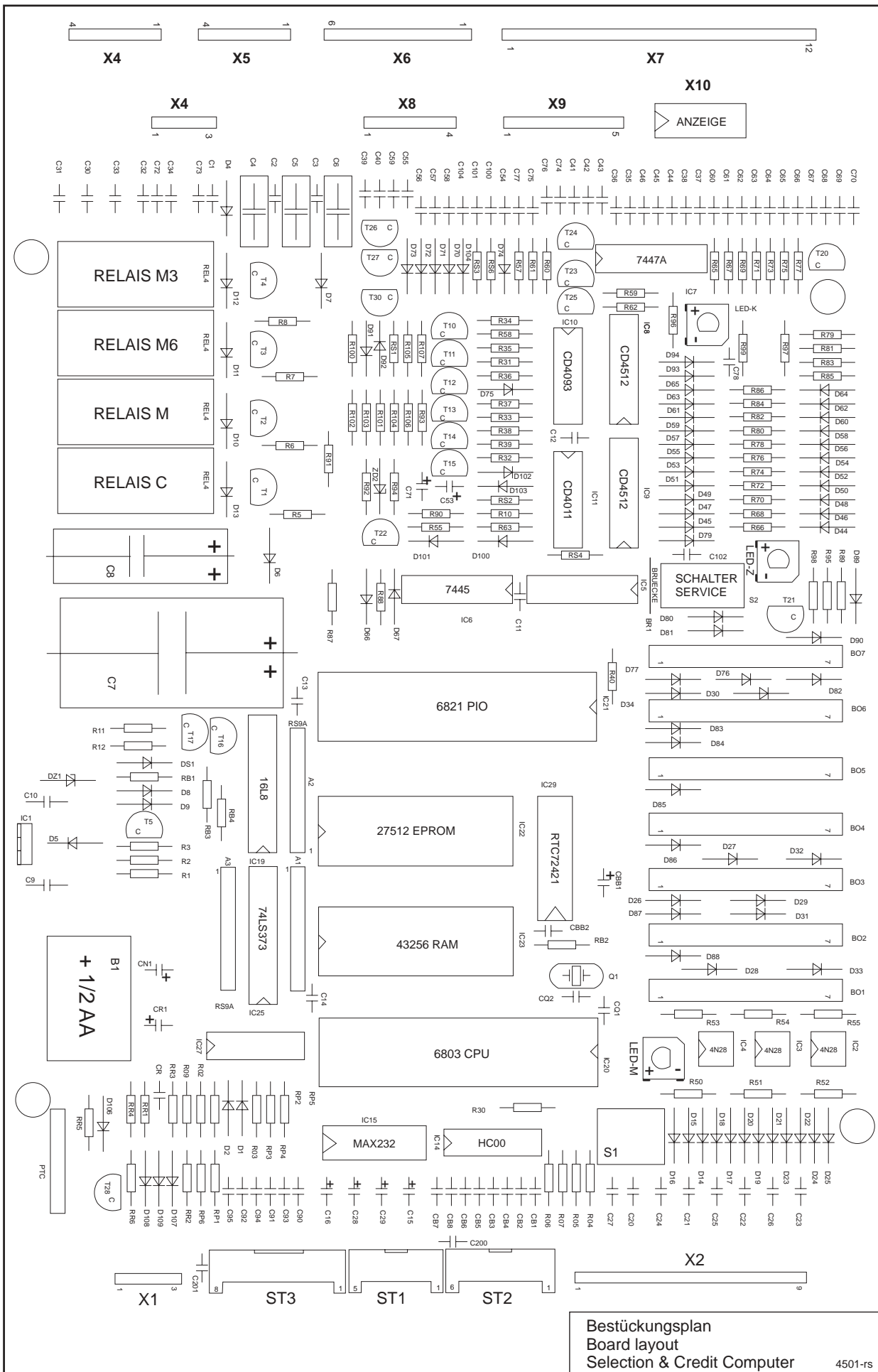

# 19.4 Wiring diagram Selection & Credit Computer

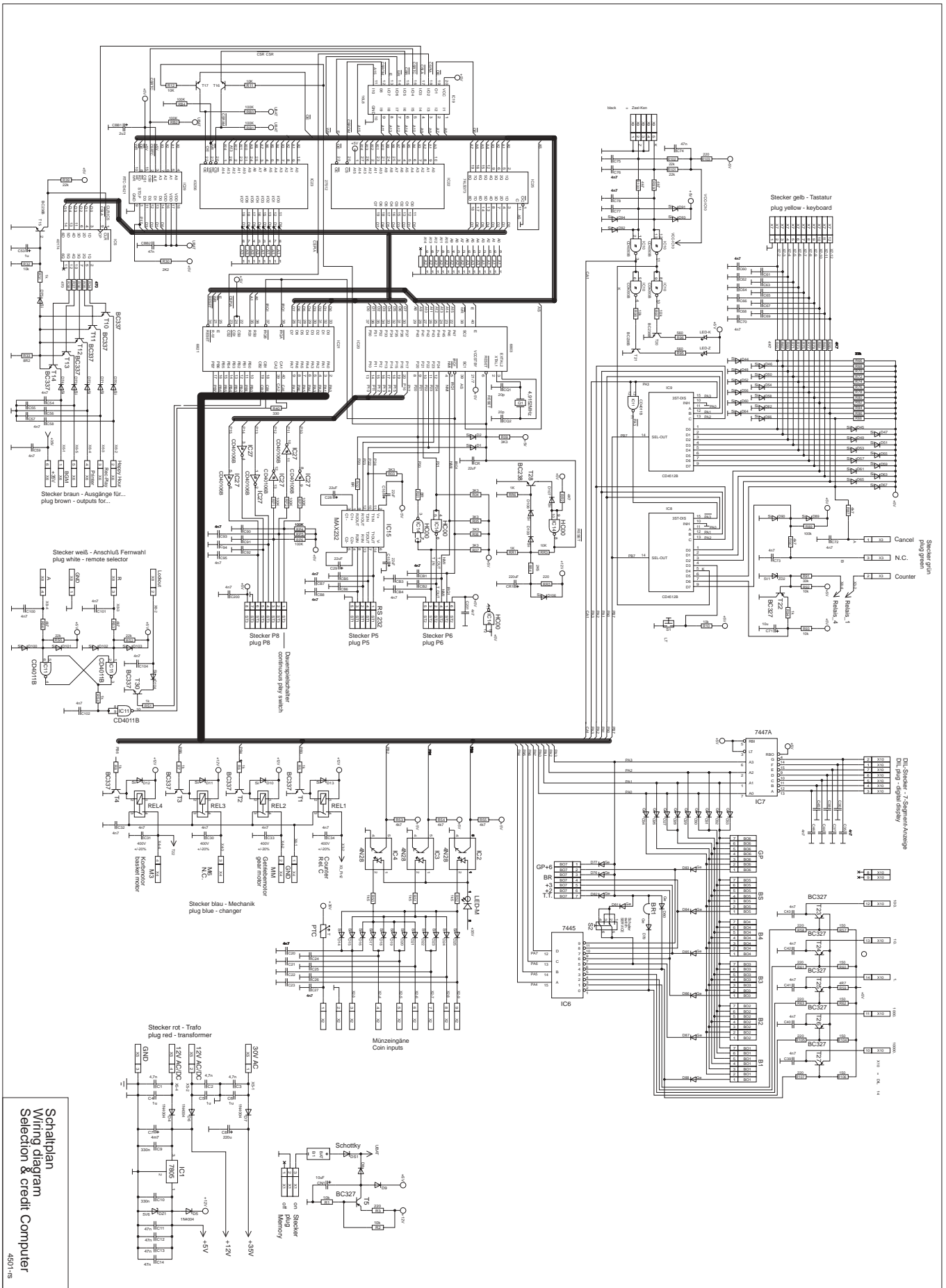

## 19.5 Board layout CDM12 SC

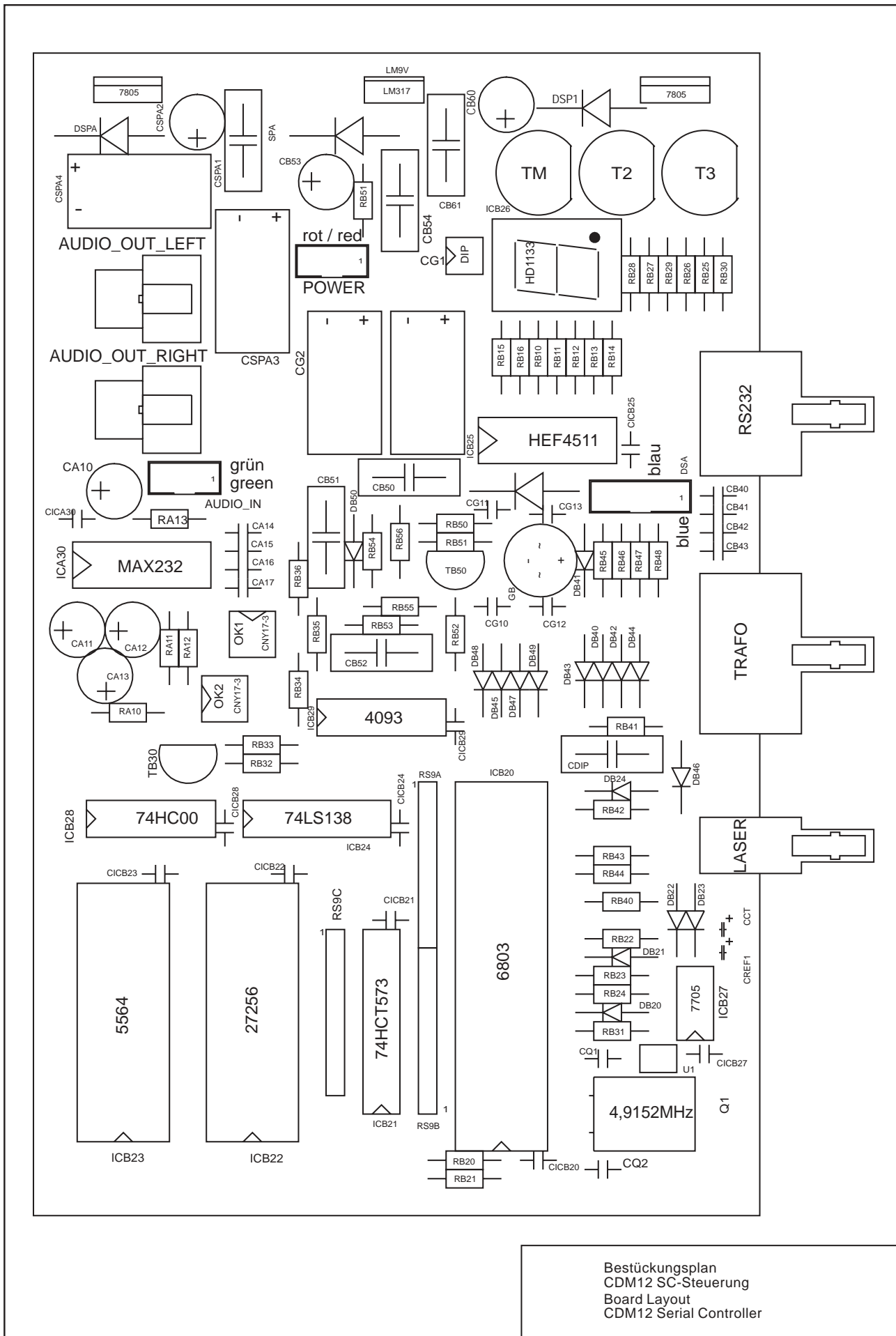

# 19.6 Wiring diagram CDM12 SC

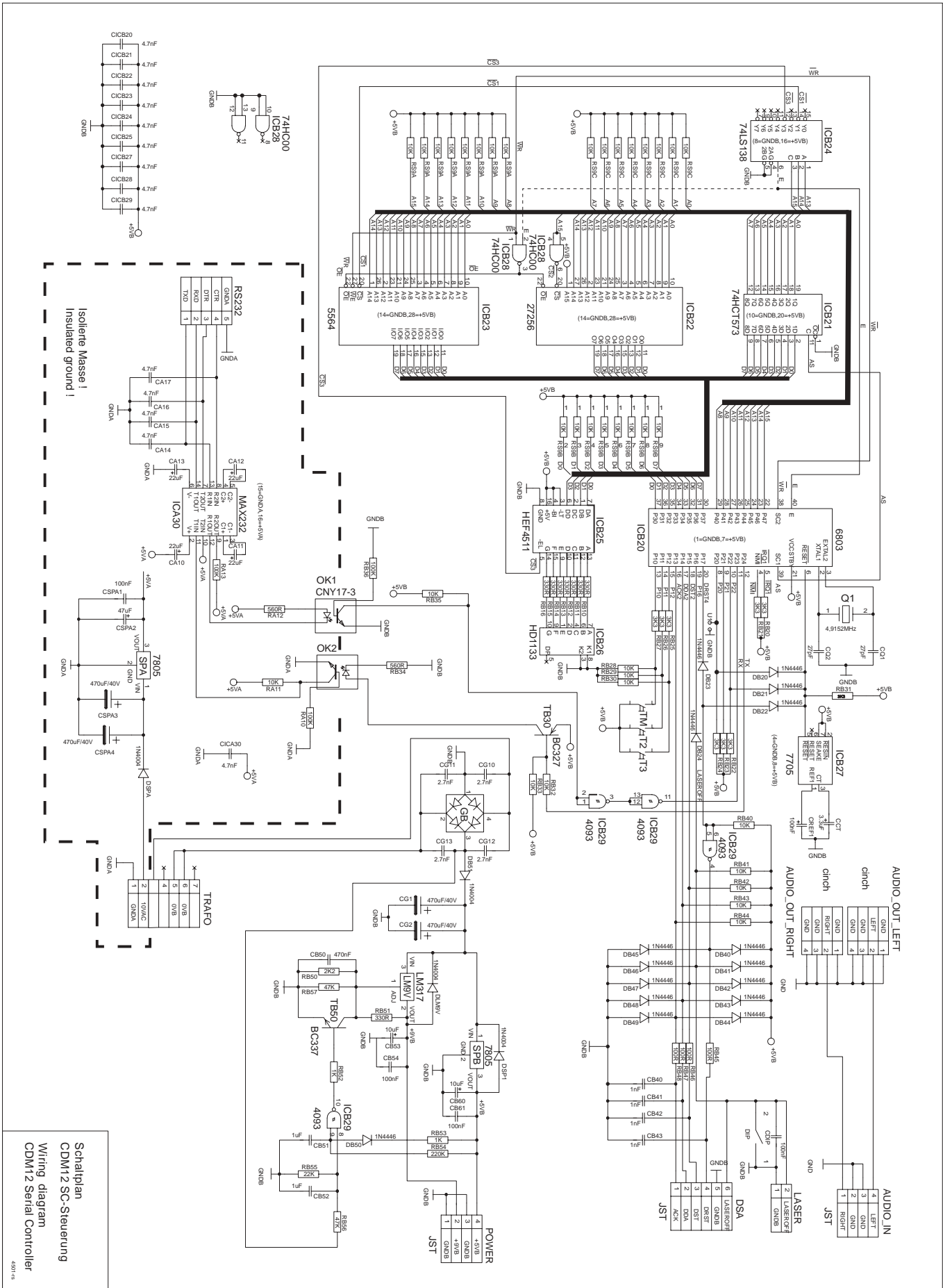

Isolierte Masse!  
Insulated ground!

Schaltplan  
CDM12 SC-Steuerung  
Wiring diagram  
CDM12 Serial Controller

4591 14

## 19.7 Wiring diagram 24V distributor interface

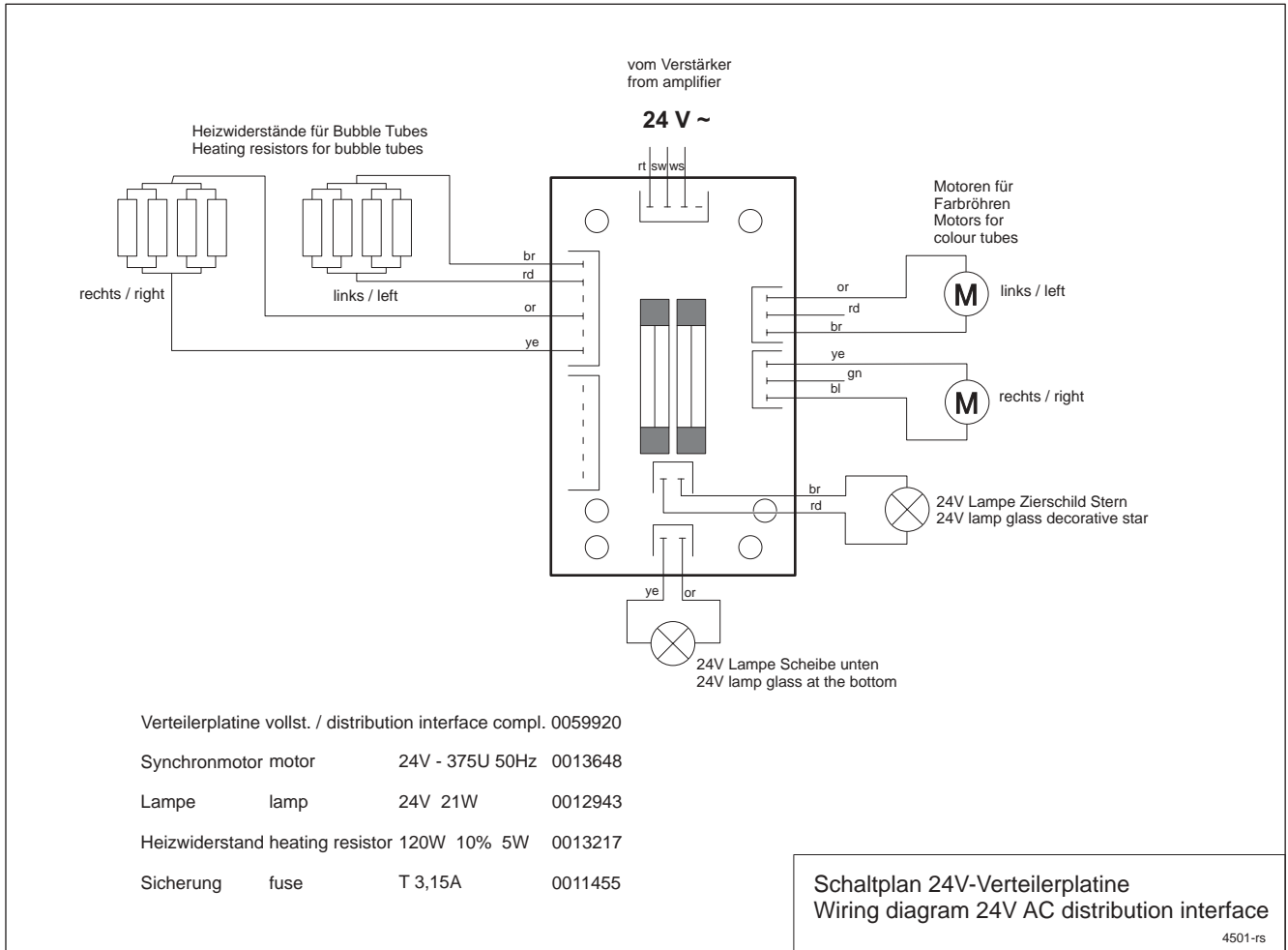

## 19.8 Wiring diagram motor page system

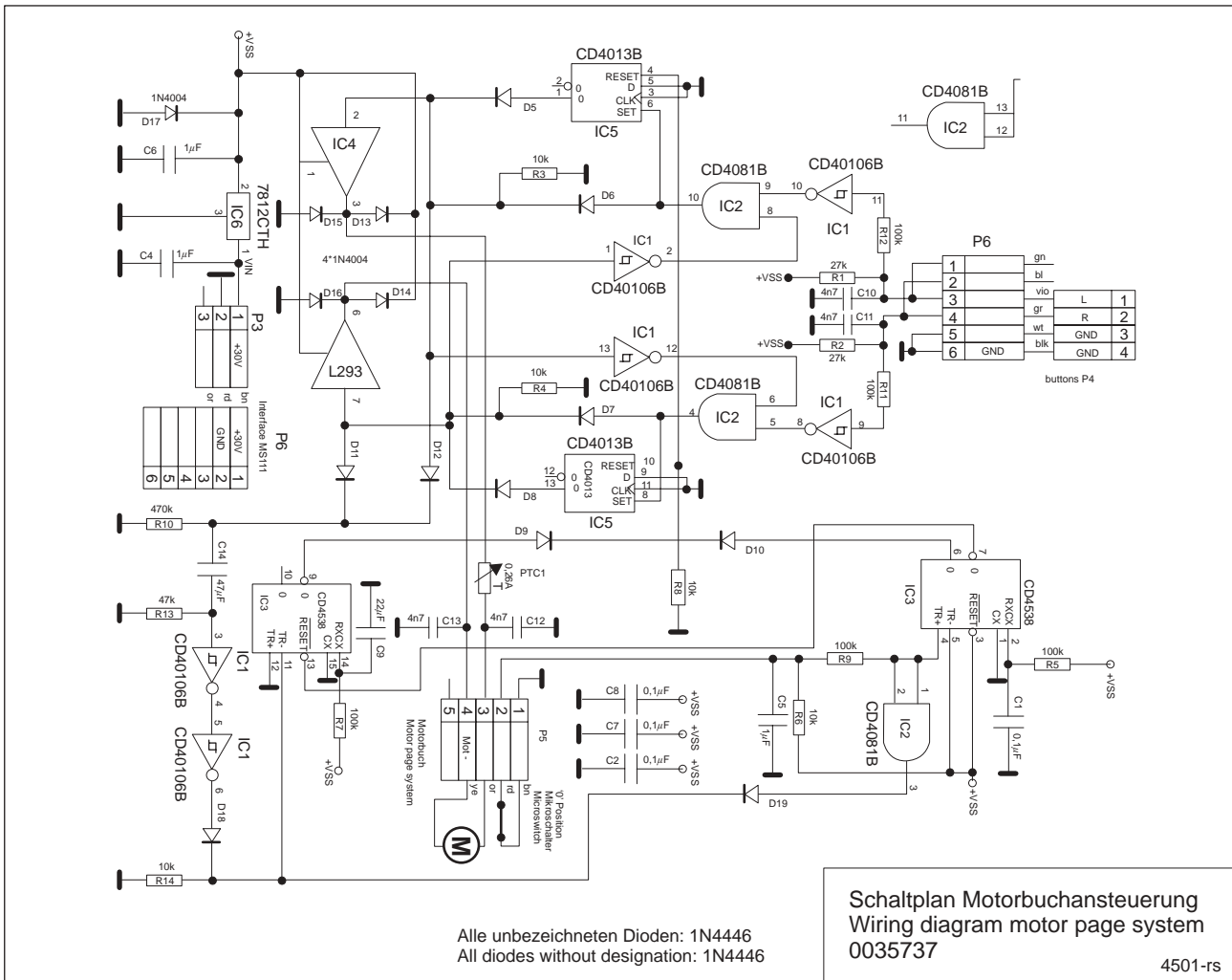



## 19.9 Wiring diagram bubble tubes

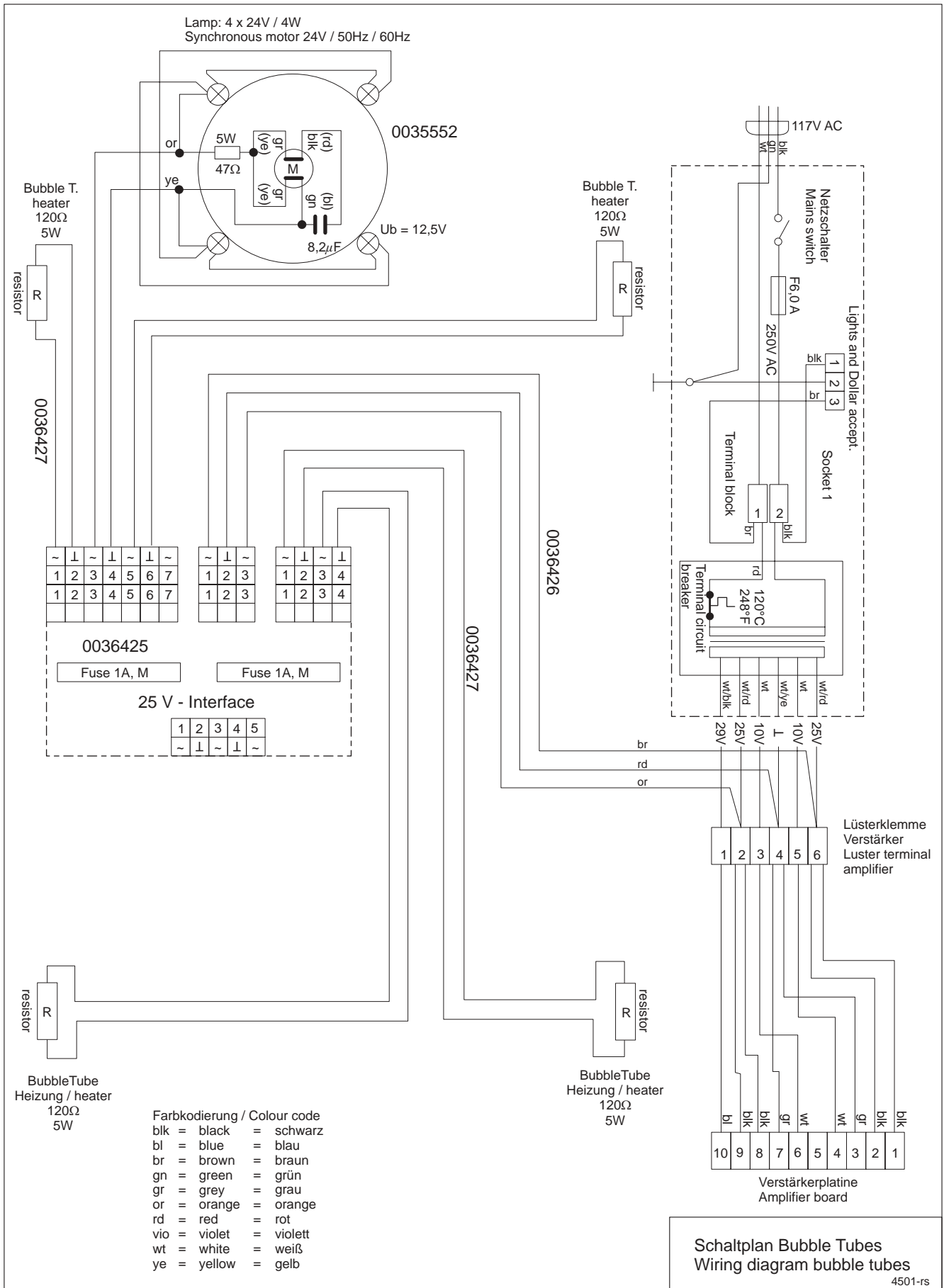

### 19.10 Wiring diagram K99 - power supply

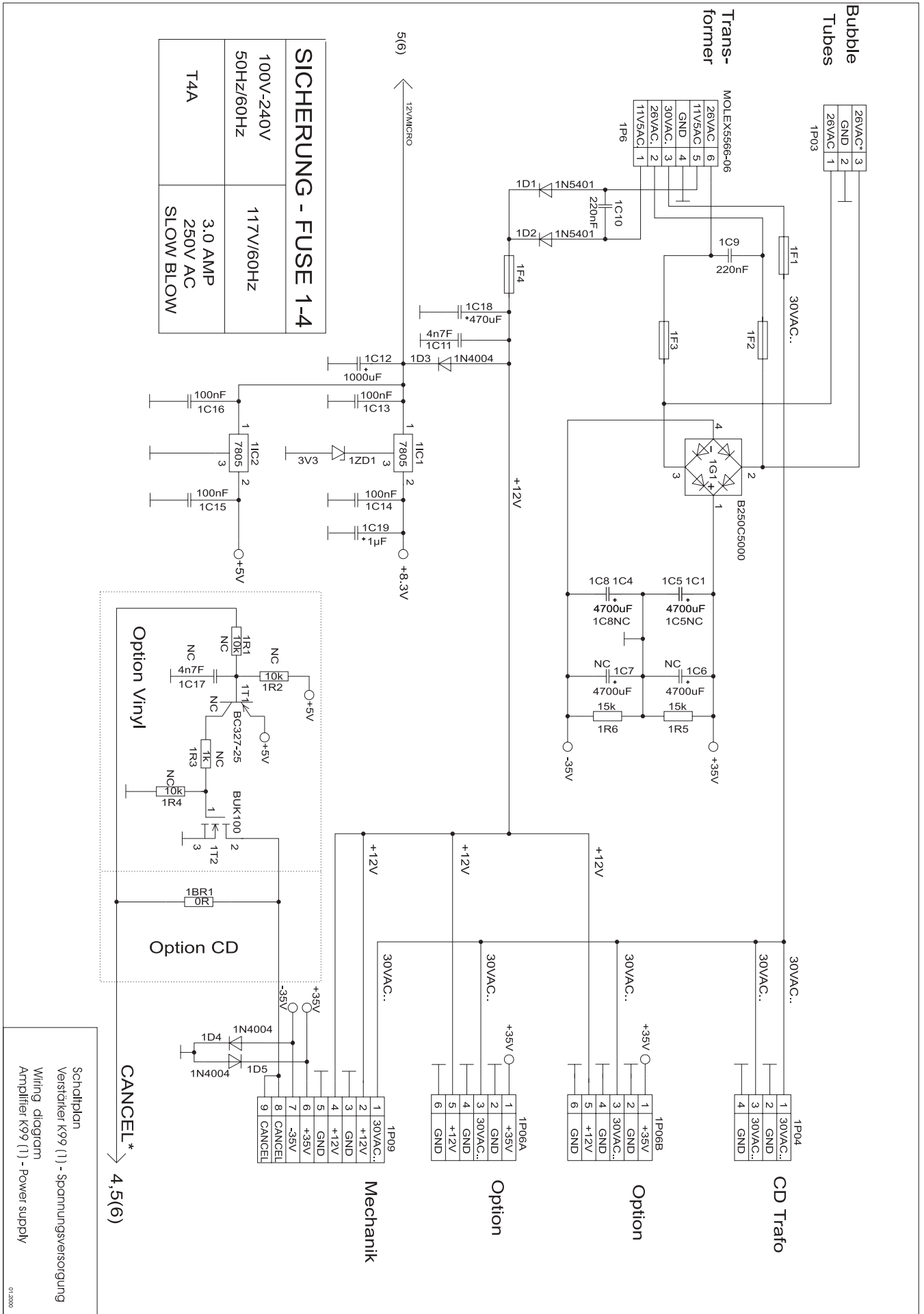

### 19.11 Wiring diagram K99 - output transformer

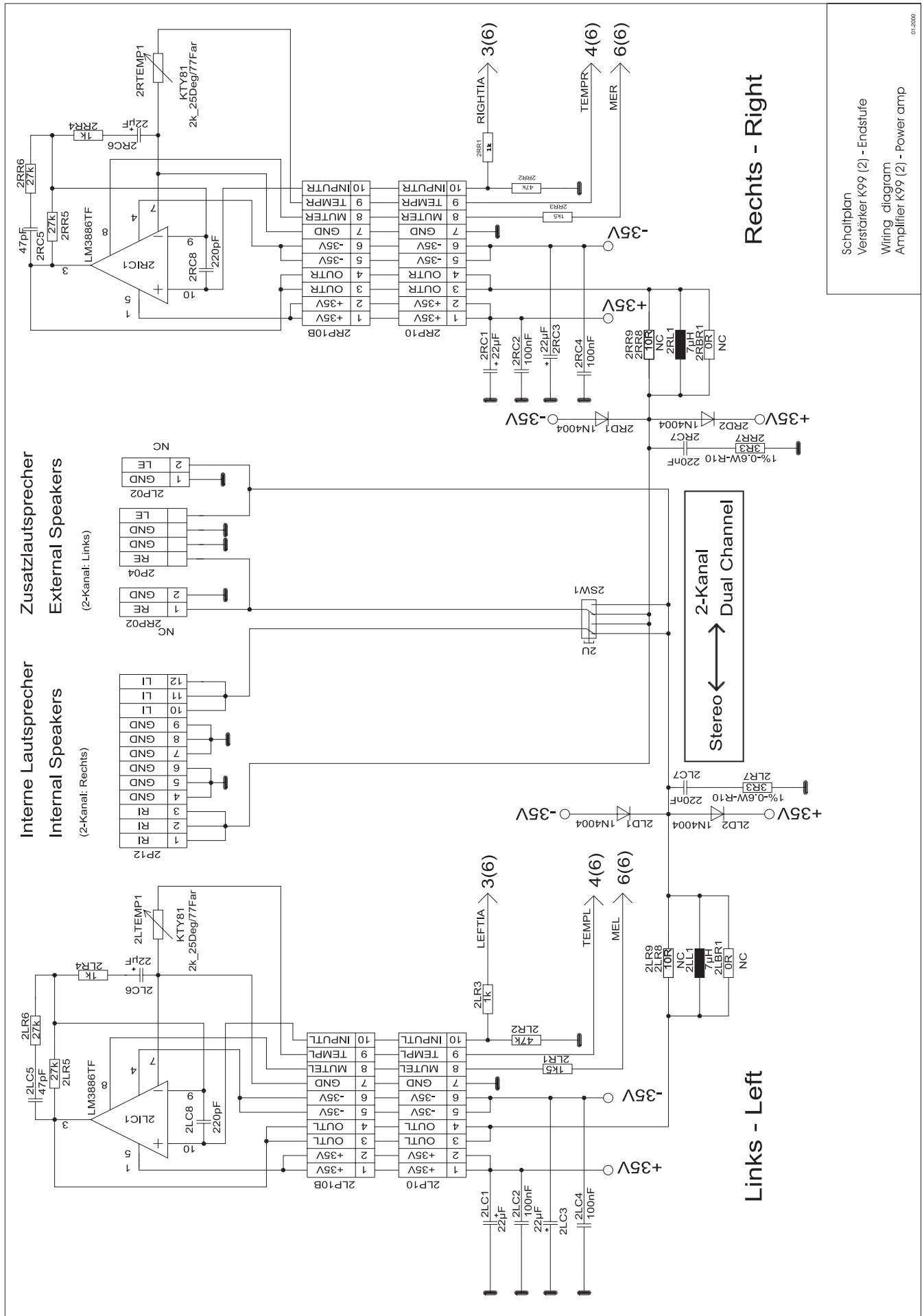

Schaltplan  
Verstärker K99 (2) - Endstufe  
Wiring diagram  
Amplifier K99 (2) - Power amp

01-2008

### 19.12 Wiring diagram K99 - pre-amplifier

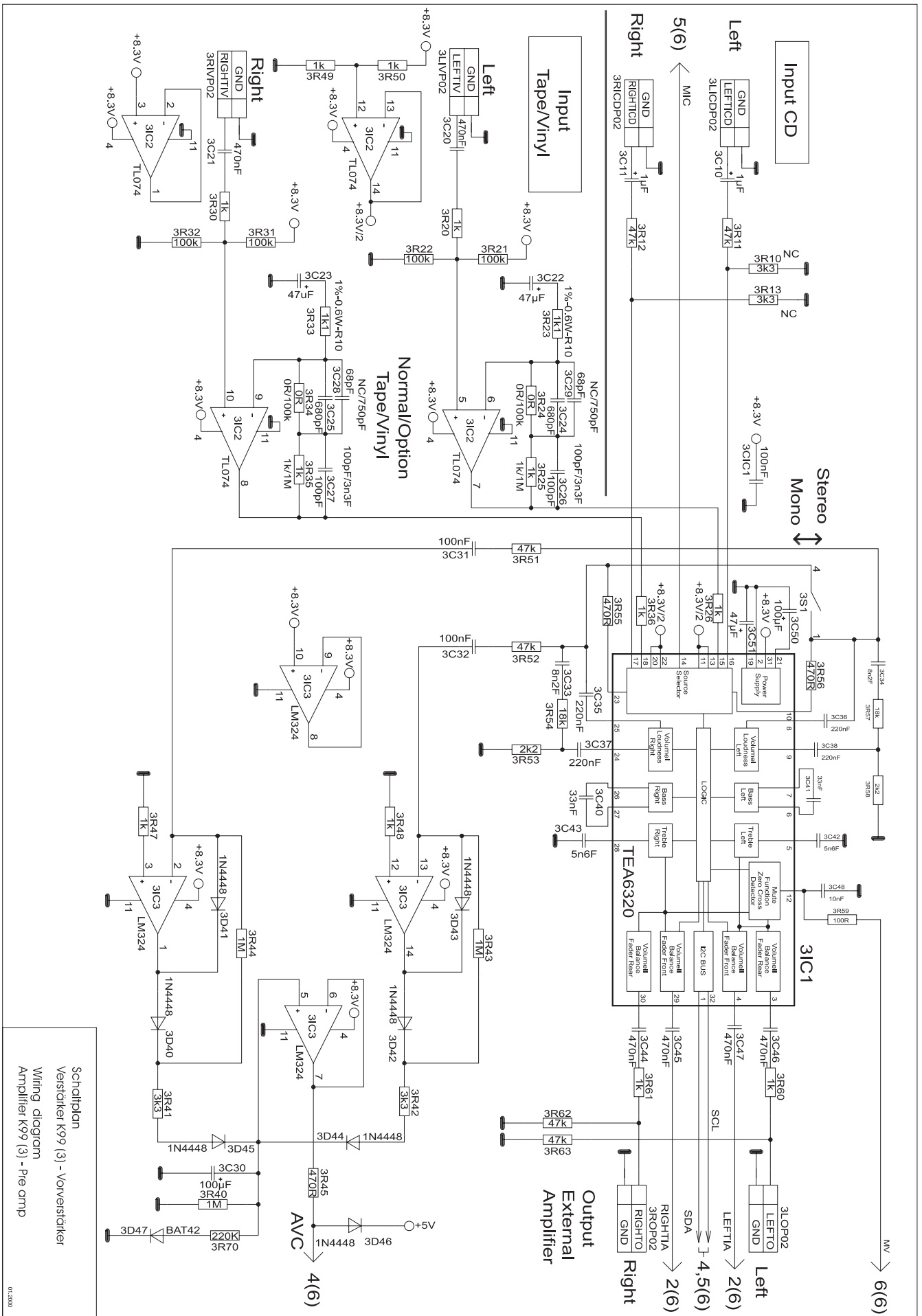

Schaltplan  
Verstärker K99 (3) - Vorverstärker  
Wiring diagram  
Amplifier K99 (3) - Pre amp

01-2000

### 19.13 Wiring diagram K99 - sound control

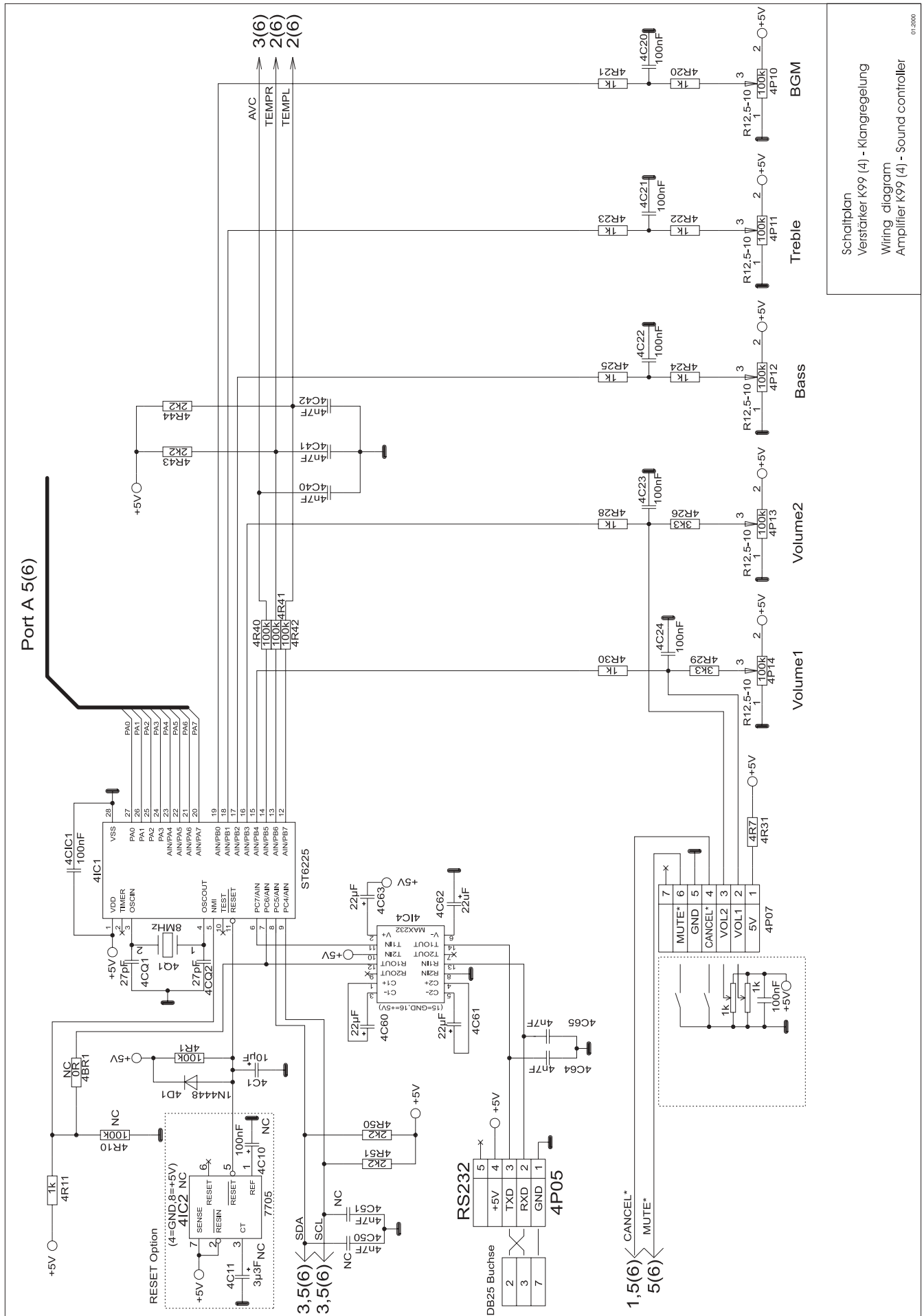

Schaltplan  
Verstärker K99 (4) - Klangregelung  
Wiring diagram  
Amplifier K99 (4) - Sound controller

01-2000

### 19.14 Wiring diagram K99 - port A

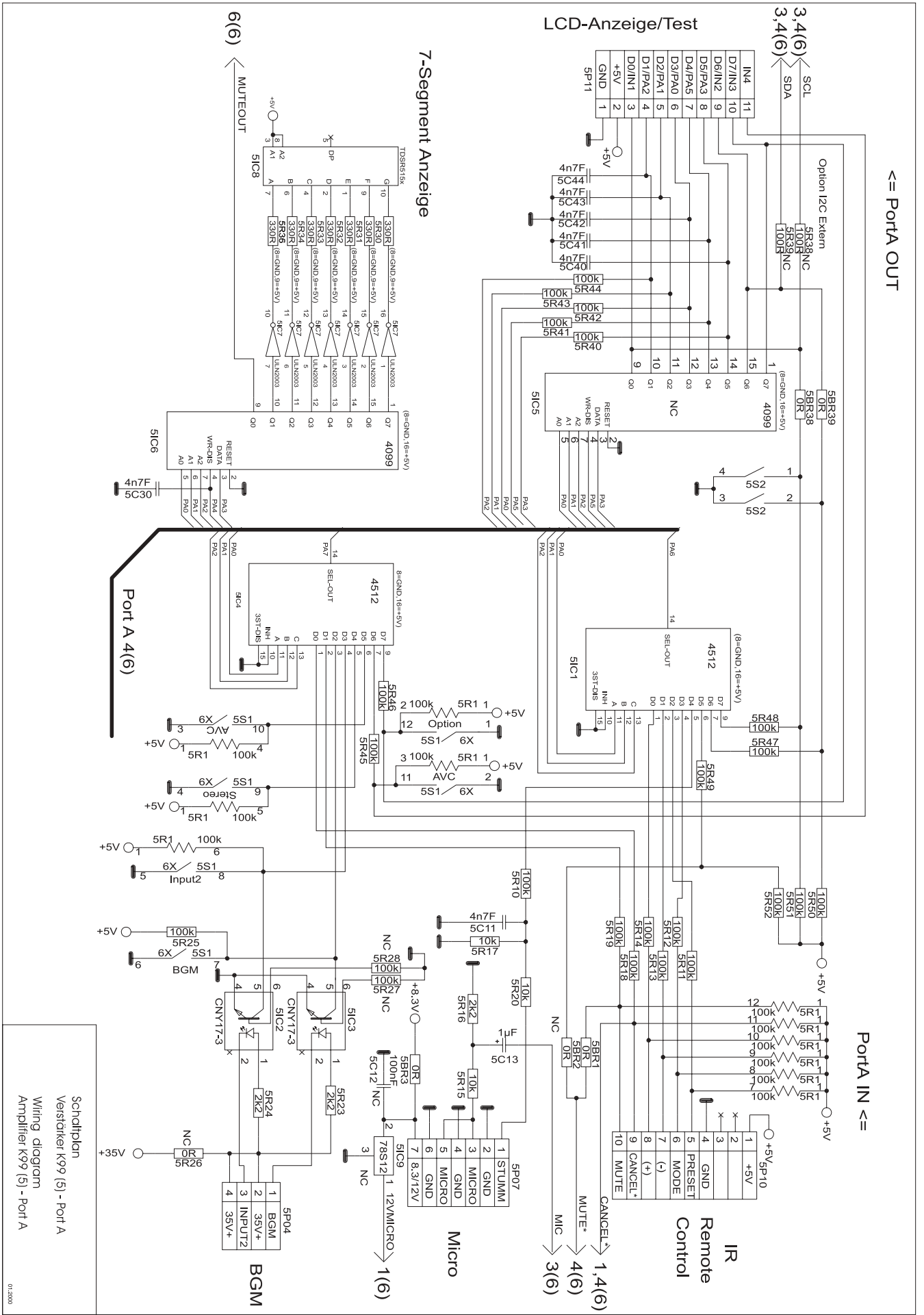

### 19.15 Wiring diagram K99 - Mute

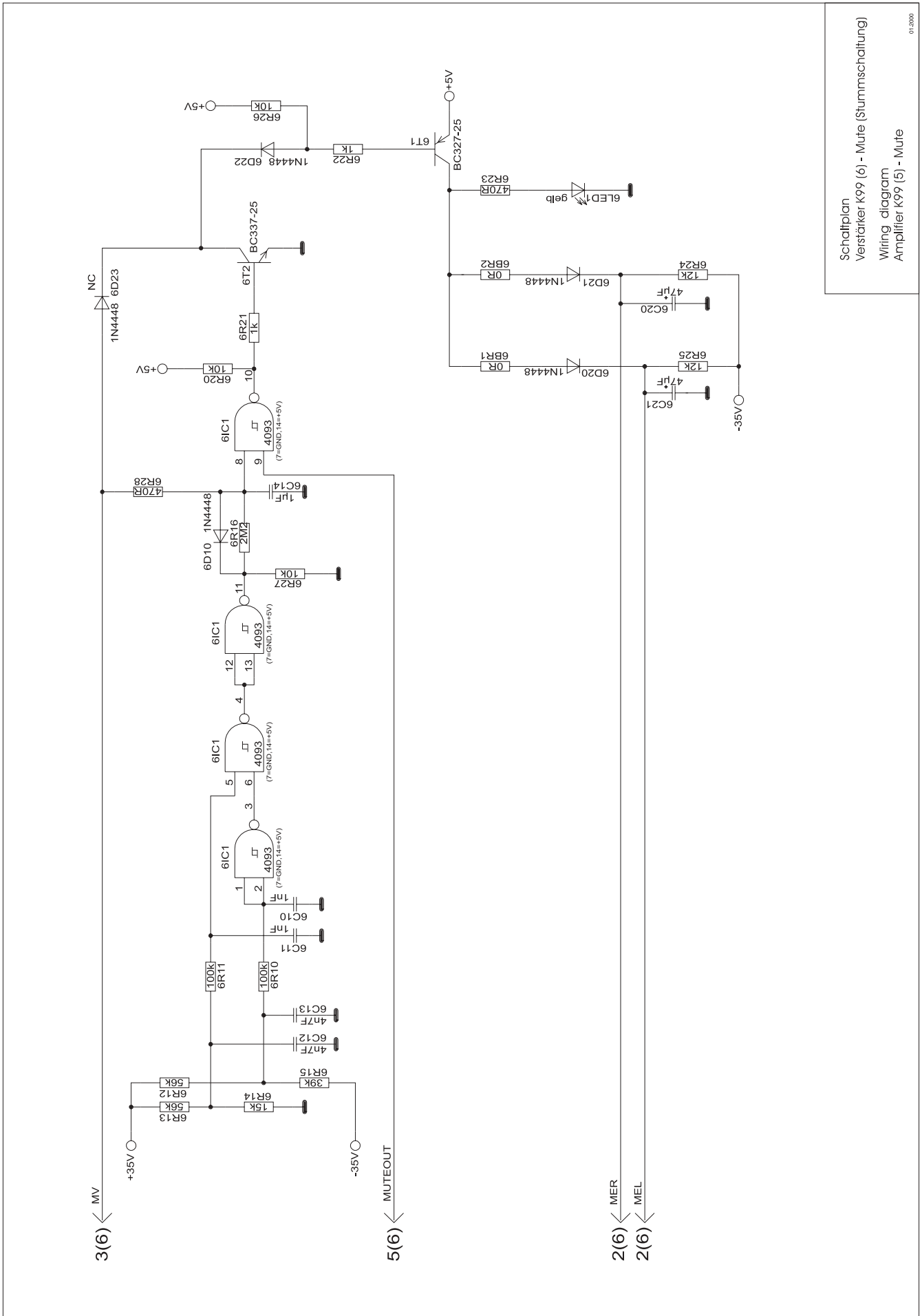

Schaltplan  
Verstärker K99 (6) - Mute (Stummschaltung)  
Wiring diagram  
Amplifier K99 (6) - Mute

01-2000

# 19.16 Wiring diagram K99 - power supply Euro 230V

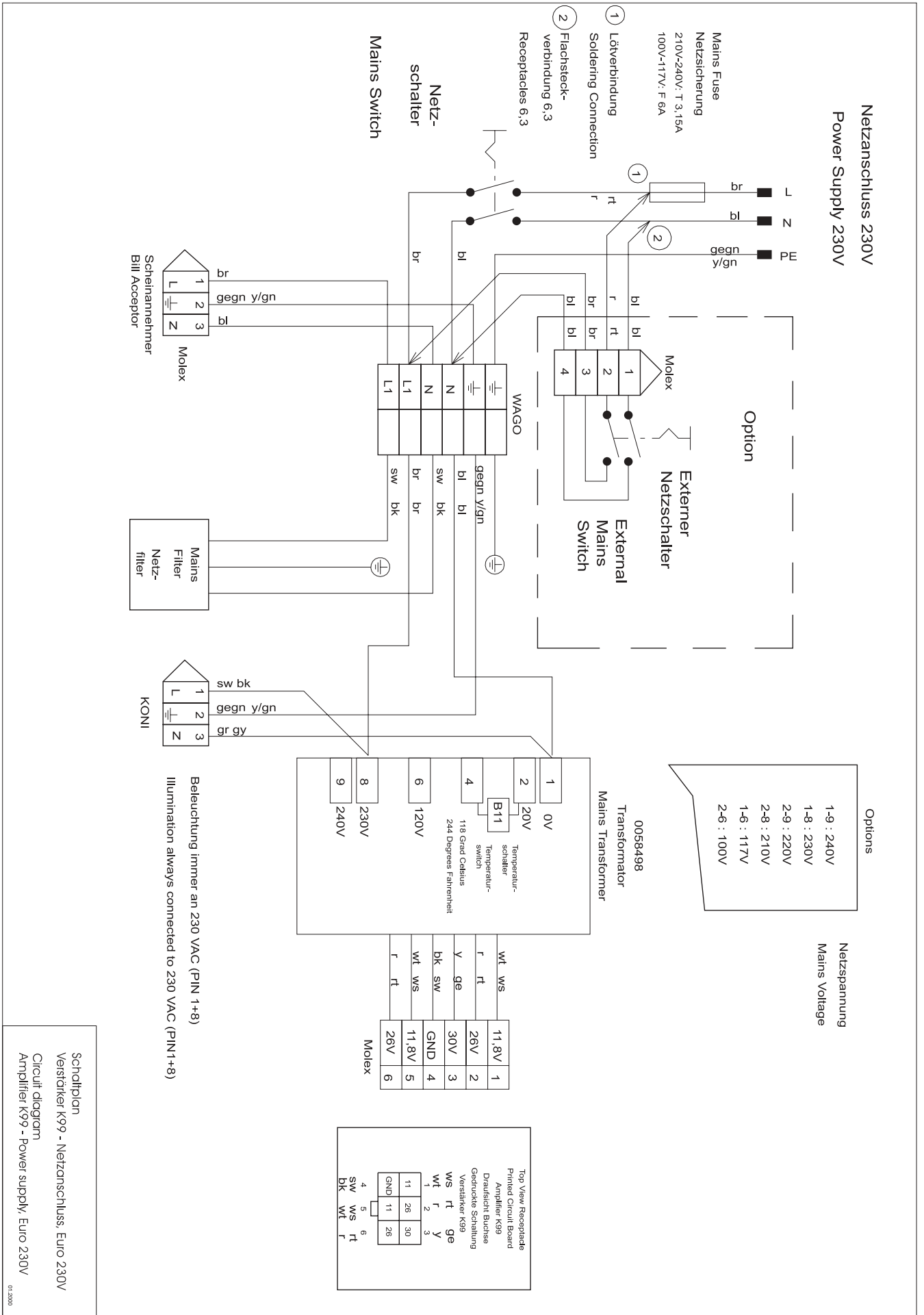



### 19.17 Wiring diagram K99 - power supply UL/USA 117V

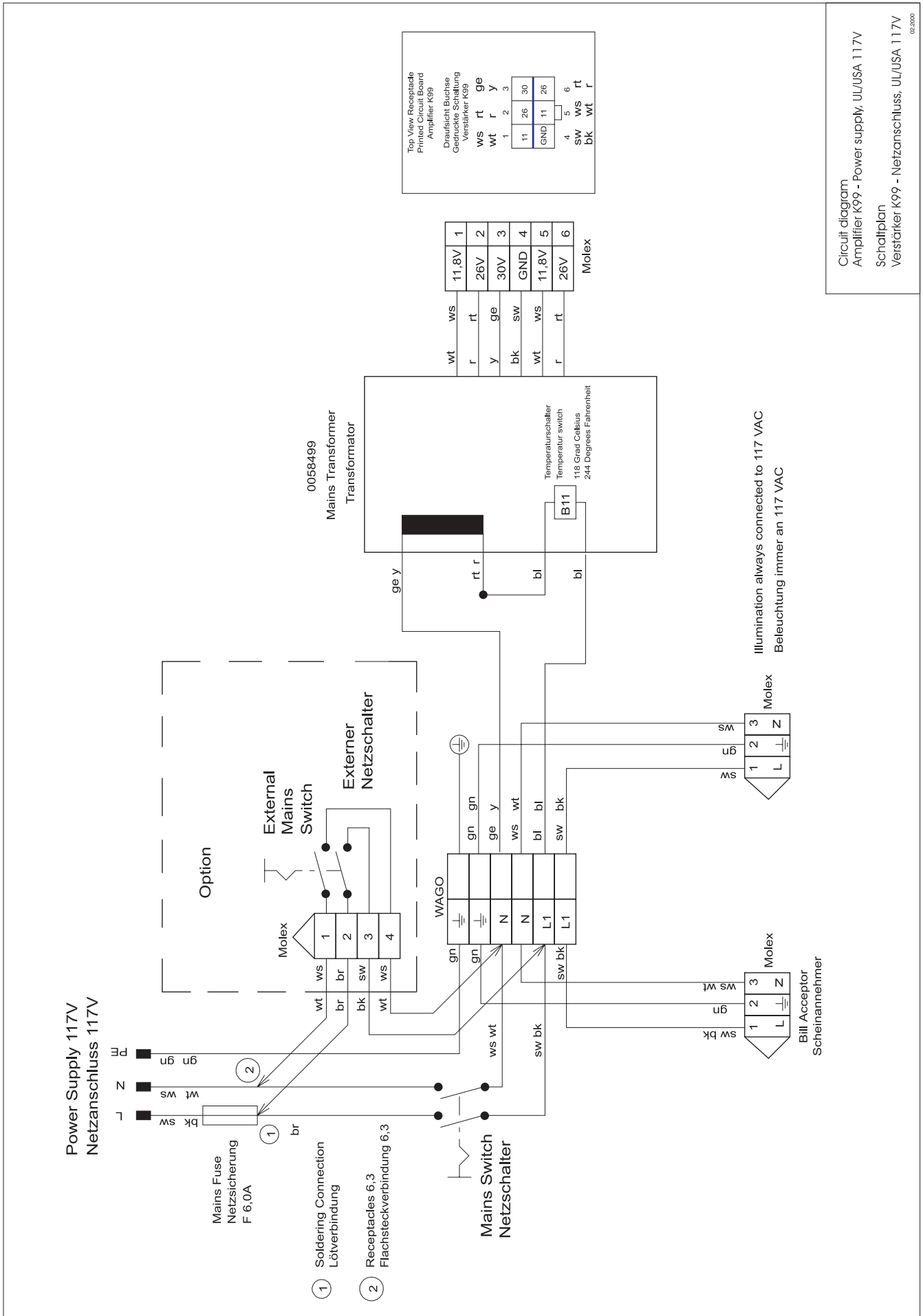

Circuit diagram  
Amplifier K99 - Power supply, UL/USA 117V  
Schaltplan  
Verstärker K99 - Netzanschluss, UL/USA 117V  
02-2000

## 20 Declaration of Conformity

Konformitätserklärung – Declaration of Conformity – Déclaration de Conformité		
<b>Geräteart:</b> <b>Product Description:</b> <b>Description Du Produit:</b>	Musikbox Jukebox Juke-box	
<b>Typenbezeichnung:</b> <b>Model No.:</b> <b>Modèle No.:</b>	<b>ONE MORE TIME (OMT) CD</b>	
<b>Angewandte EG-Richtlinien:</b> <b>Directives Complied with:</b> <b>Directives de la CE:</b>	73/23/EEC	Niederspannungsrichtlinie Low voltage directive Directive relative aux appareils à basse tension
	89/336/EEC	Elektromagnetische Verträglichkeit EMC Directive Directive Relative à la compatibilité électromagnétique
<b>Technische Vorschriften:</b> <b>Standards used:</b> <b>Régulation Technique:</b>	EN 50081-1	Elektromagnetische Verträglichkeit Fachgrundnorm Störaussendung Electromagnetic compatibility Generic Emissions Requirements Compatibilité électromagnétique Norme générique emission
	EN 50082-2	Elektromagnetische Verträglichkeit Fachgrundnorm Störaussendung Electromagnetic Compatibility Generic Emissions Requirements Compatibilité électromagnétique Norme générique emission
	EN 60335-1	Sicherheit elektrischer Geräte für den Hausgebrauch und ähnliche Zwecke Safety of household and similar Electrical appliances Sécurité des appareils électrodomestiques et analogues
	EN 60335-75	Grenzwerte und Messverfahren für Funkstörungen von informationstechnischen Einrichtungen Limits and methods of measurement of radio interference characteristics of information technology equipment Sécurité des appareils électrodomestiques et analogues
	EN 55022	Grenzwerte Und Messverfahren Für Funkstörungen Von Informationstechnischen Einrichtungen Limits And Methods Of Measurement Of Radio Interference Characteristics Of Information Technology Equipment.
<b>Unterschrift/Signature/</b> <b>Signature</b>		
<b>Gedruckter Name/Print</b> <b>name/nom</b>	Jürgen Obermeier	
<b>Position/Position/Position</b>	Chief Engineer/Technischer Leiter/Directeur Technique	
<b>Datum/Date/Date</b>	2. Januar 1995 / 2. January 1995 / 2. Janvier 1995	



# WURLITZER®

**Germany**

Deutsche Wurlitzer GmbH  
Wurlitzerstraße 6  
D-32609 Hüllhorst  
Tel.: +49(0) 57 44 - 941-0  
Fax: +49(0) 57 44 - 941 220  
[contact@deutsche-wurlitzer.de](mailto:contact@deutsche-wurlitzer.de)

Wurlitzer® A Registered Trademark of the Gibson Guitar Corporation

Art.-Nr.: 0073254  
Edition 4708