

BEFORE USING THE PRODUCT, BE SURE TO READ THE FOLLOWING:

To maintain safety:

To ensure the safe operation of this product, be sure to read the following before usage. The following instructions are intended for the users, operators and the personnel in charge of the operation of the product. After carefully reading and sufficiently understanding the warning displays and cautions, handle the product appropriately. Be sure to keep this manual close to the product or in a convenient place for future reference.

Herein, explanations which require special attention are enclosed with dual lines. Depending on potentially hazardous degrees, the terms of DANGER, WARNING, CAUTION, etc. are used. Be sure to understand the contents of the displays before reading the text.



DANGER

Indicates that mishandling the product by disregarding this pictograph will cause severe injury or death.



WARNING

Indicates that mishandling the product by disregarding this warning will cause a potentially hazardous situation which can result in death or serious injury.



CAUTION

Indicates that mishandling the product by disregarding this caution will cause a slight hazardous situation which can result in personal injury and/or material damage.

For the safe usage of the product, the following pictographs are used:

Indicates "HANDLE WITH CARE." In order to protect the human body and equipment, this display is attached to places where the Owner's Manual, Serviceman Manual and/or Service Manual should be referred to.

- **Perform work in accordance with the instructions herein stated.** Instructions for work are explained by paying attention to the aspect of accident prevention. Failing to perform work as per the instructions can cause accidents. In the case where only those who have technical expertise should perform the work to avoid hazardous situation, the instructions herein state that the site maintenance personnel should perform such work.
- **Be sure to turn off the power before working on the machine.** To prevent an electric shock, be sure to turn off the power before carrying out any work that requires direct contact with the interior of the product. If the work is to be performed in the power-on status, the Instruction Manual herein always states to that effect.
- **Be sure to ground the Earth Terminal.** (This is not required in the case where a power cord with earth is used.)
- **This product is equipped with the Earth Terminal.** When installing the product, connect the Earth Terminal to the "accurately grounded indoor earth terminal" by using an earth wire. Unless the product is grounded appropriately, the user can be subject to an electric shock. After performing repair, etc. for the control equipment, ensure that the Earth Wire is firmly connected to the control equipment.
- **Ensure that the Power Supply used is equipped with an Earth Leakage Breaker.** This product does not incorporate the Earth Leakage Breaker. Using a power supply which is not equipped with the Earth Leakage Breaker can cause a fire when earth leakage occurs.
- **Be sure to use fuses which meet the rating.** (Only for the machines which use fuses.) Using fuses exceeding the specified rating can cause a fire and an electric shock. (Only for the machines which use fuses).

- **Specification changes (removal of equipment, conversion and addition) not designated by SEGA are not allowed.** The parts of the product include warning labels for safety, covers for personal protection, etc. It is very hazardous to operate the product by removing parts and/or modifying the circuits. Should doors, lids and protective parts be damaged or lost, refrain from operating the product, and contact where the product was purchased from or the office herein stated. SEGA shall not be held responsible for any accidents, compensation for damage to a third party, resulting from the specifications not designated by SEGA.
- Ensure that the product meets the requirements of appropriate electrical specifications. Before installing the product, check for electrical specifications. SEGA products have a nameplate on which electrical specifications are described. Ensure that the product is compatible with the power supply voltage and frequency requirements of the location. Using any electrical specifications different from the designated specifications can cause a fire and an electric shock.
- Install and operate the product in places where appropriate lighting is available, allowing warning labels to be clearly read. To ensure safety for the customers, labels and printed instructions describing potentially hazardous situations are applied to places where accidents can be caused. Ensure that where the product is operated has sufficient lighting allowing the warnings to be read. If any label peeled off, apply it again immediately. Please place an order with where the product was purchased from or the office herein stated.
- When handling the monitor, be very careful. (Applies only to products with monitors.) Some of the monitor parts are subject to high tension voltage. Even after turning off the power, some portions are still subject to high tension voltage sometimes. Monitor repair and replacement should be performed only by those technical personnel who have knowledge of electricity and technical expertise.
- Be sure to adjust the monitor properly. (Applies only to products with monitors.) Do not operate the product leaving on-screen flickering or blurring as it is. Using the product with the monitor not properly adjusted may cause dizziness or a headache to an operator, a player, or the customers.
- When transporting or reselling this product, be sure to attach this manual to the product.
- *In the case where commercially available monitors and printers are used in this product, only the contents relating to this product are explained herein. Some commercially available equipment has functions and reactions not stated in this manual. Read this manual together with the instruction manual of such equipment.*
- *Descriptions herein contained may be subject to improvement changes without notice.*
- *The contents described herein are fully prepared with due care. However, should any question arise or errors be found, please contact SEGA.*

INSPECTIONS IMMEDIATELY AFTER TRANSPORTING THE PRODUCT TO THE LOCATION

Normally, at the time of shipment, SEGA products are in a status allowing for usage immediately after transporting to the location. Nevertheless, an irregular situation may occur during transportation. Before turning on the power, check the following points to ensure that the product has been transported in a satisfactory status.

- Are there any dented portions or defects (cuts, etc.) on the external surfaces of the cabinet?
- Are casters and adjusters damaged?
- Do the power supply voltage and frequency requirements meet with those of the location?

- Are all wiring connectors correctly and securely connected? Unless connected in the correct way, connector connections cannot be made accurately. Do not insert connectors forcibly.
- Do power cables have cuts and dents?
- Are all accessories available?
- Can all doors and lids be opened with the accessory keys? Can doors and lids be firmly closed?

INTRODUCTION

This manual is intended to provide detailed descriptions together with all necessary information covering the general operation of electronic assemblies, electro-mechanicals, servicing control, spare parts, etc. for the product, "PLANTS VS ZOMBIES."

This manual is intended for the owners, personnel managers in charge of operation of this product. Operate the product after carefully reading and sufficiently understanding the instructions.

In the unlikely event that the product does not function correctly, DO NOT allow anyone other than a technician to touch the internal system. Turn off the power to the machine, making sure to unplug the electrical cord from the outlet, and contact the office listed below or the point-of-purchase for this product.

Use of this product is unlikely to cause physical injuries or damage to property. However, points that require special attention are indicated by bold text, the word "IMPORTANT" and the symbol below.



INDICATES IMPORTANT INFORMATION THAT, IF IGNORED, MAY RESULT IN THE MISHANDLING OF THE PRODUCT AND CAUSE FAULTY OPERATION OR DAMAGE TO THE PRODUCT.

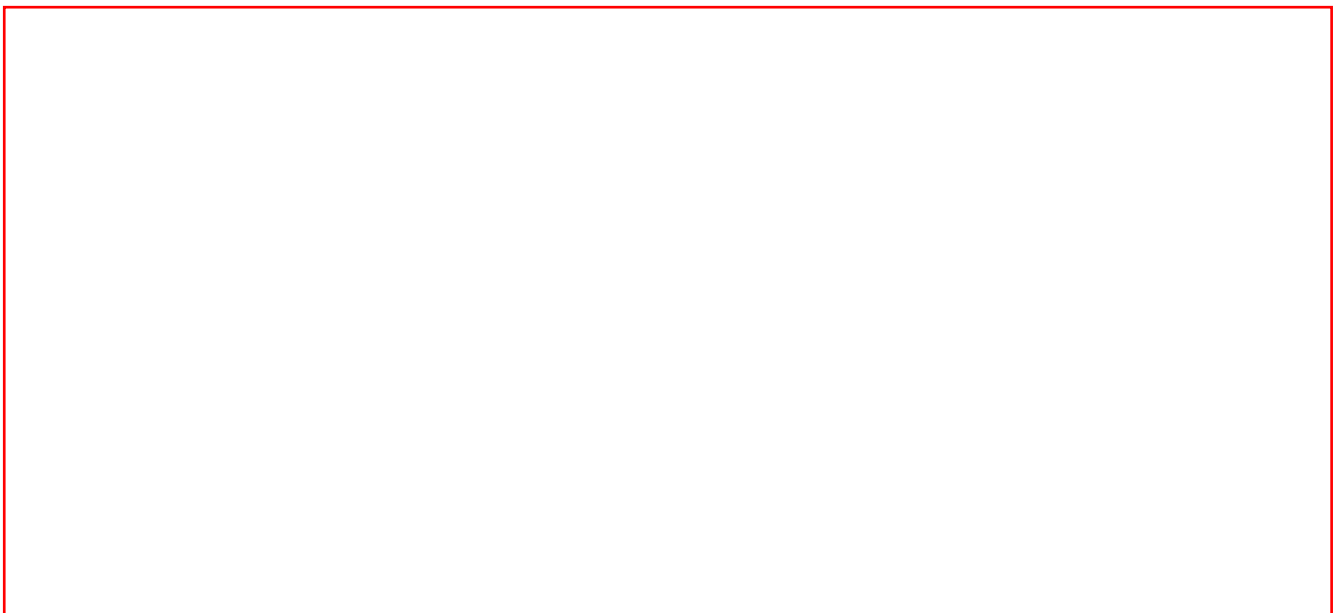

SPECIFICATIONS

CABINET

MACHINE DIMENSIONS:	W 75 cm (29.53") x D 75 cm (29.53")
MACHINE HEIGHT:	H 206 cm (81.10") [INSTALLED]
MACHINE WEIGHT:	120 Kgs. (265 LBS.)
POWER, MAXIMUM CURRENT:	220V ~ 12 AMP [UK/EUROPE] 110V/AC ~ 24 AMP [USA]

DEFINITION OF: "SITE MAINTENANCE PERSONNEL OR OTHER QUALIFIED INDIVIDUALS"



PROCEDURES NOT DESCRIBED IN THIS MANUAL OR MARKED AS "TO BE CARRIED OUT BY SITE MAINTENANCE PERSONNEL OR OTHER QUALIFIED PROFESSIONALS" SHOULD NOT BE CARRIED OUT BY PERSONNEL WITHOUT THE NECESSARY SKILL OR TECHNOLOGY. WORK CARRIED OUT BY UNQUALIFIED PERSONS MAY CAUSE SERIOUS ACCIDENTS, INCLUDING ELECTROCUTION.

Parts replacement, maintenance inspections and troubleshooting should be carried out by site maintenance personnel or other qualified professionals. This manual includes directions for potentially dangerous procedures which should only be carried out by professionals with the appropriate specialized knowledge.

The site maintenance personnel or other qualified professionals mentioned in this manual are defined as follows;

Site maintenance personnel:

Individuals with experience in maintaining amusement equipment, vending machines, etc., working under the supervision of the owner/operator of this product to maintain machines within amusement facilities or similar premises by carrying out everyday procedures such as assembly, maintenance inspections, and replacement of units/expendable parts.

Activities to be carried out by site maintenance personnel:

Amusement equipment/vending machine assembly, maintenance inspection and replacement of units/expendable parts.

Other qualified professionals continued on the following page;

Other qualified professionals;

Persons employed by amusement equipment manufacturers, or involved in design, production, testing or maintenance of amusement equipment. The individual should have either graduated from technical school or hold similar qualifications in electrical/ electronics /mechanical engineering.

Activities to be carried out by other qualified professionals;

Amusement equipment/vending machine assembly, repair/adjustment of electrical/electronic/mechanical parts.

WASTE OF ELECTRICAL AND ELECTRONIC EQUIPMENT (WEEE) STATEMENT.

The WEEE (Waste of Electrical and Electronic Equipment) directive places an obligation on all EU based manufacturers and importers of Electrical and Electronic Equipment to take back products at the end of their useful life. Sega Amusements Europe Ltd. Accepts it's responsibility to finance the cost of treatment and recovery of redundant WEEE in the United Kingdom in accordance with the specific WEEE recycling requirements.

The symbol shown below will be on all products manufactured from 13th August 2005, which indicates this product must NOT be disposed of with other normal waste. Instead, it is the user's responsibility to dispose of their waste equipment by arranging to return it to a designated UK collection point for the correct recycling of waste electrical and electronic equipment.

For more information about where you can send your waste equipment for recycling contact your local authority office.

For non-UK users, contact your local authority office for information on the recycling of Waste Electrical and Electronic Equipment.

BATTERY RECYCLING STATEMENT

The EC Directive on Batteries and Accumulators (2006/66/EC) aims to minimize the impact of batteries on the environment and encourage the recovery of the materials they contain. To achieve increased collection and recycling of waste batteries, the Directive places 'producer responsibility' obligations on manufacturers and importers of portable, industrial and automotive batteries.

The symbol shown below will be on all equipment fitted with batteries from 26th September 2008 and indicates they must NOT be disposed of with other normal waste. Instead, it is the user's responsibility to dispose of used batteries by arranging to return them to a designated collection point for the correct recycling.

For more information about where you can send your waste batteries for recycling contact your local authority office.



TABLE OF CONTENTS

INTRODUCTION

1. HANDLING PRECAUTIONS	1
2. PRECAUTIONS REGARDING INSTALLATION	1
3. PRECAUTIONS REGARDING OPERATION	1
4. LOCATION	
4-1 GAME LEVELING	1
5. GAME DESCRIPTION	
5-1 OVERALL DIMENSIONS and APPEARANCE	1
6. GAME SET UP AND ADJUSTMENTS / TEST FUNCTIONS	
6-1 GAME MENU & OPTIONS SETTINGS	1
6-2 TEST FUNCTIONS	1
7. COIN HANDLING	
7-1 INSTRUCTION FOR ELECTRONIC COIN COMPARATOR TYPE	1
8. TICKET MECHANISM	
8-1 INSTALLING TICKETS	1
9. ELECTRONIC COMPONENTS	
9-1 MAIN BOARD	1
9-2 MAIN BOARD I/O	1
9-3 EXTENSION BOARD I/O	1
9-4 WIRING DIAGRAMS	1
9-5 COIL BED ASSEMBLY	1
9-6 GAME ASSEMBLY	1
10. GAME ERROR CODES	1
11. COIL BED SERVICE AND MAINTENANCE	
11-1 ACCESSING THE COIL BED	1
11-2 SERVICING THE HEADER LIGHT BOX	1
12. PARTS DESCRIPTION	
10-1 CABINET GRAPHICS & LABELS	1
10-2 PARTS LIST	1

1. HANDLING PRECAUTIONS

When installing or inspecting the machine, be very careful of the following points and pay attention to ensure that the player can enjoy the game safely.

Noncompliance with the following points or inappropriate handling running counter to the cautionary matters herein stated can cause personal injury or damage to the machine.

IMPORTANT

Before performing work, be sure to turn the power off. Performing the work without turning the power off can cause an electric shock or short circuit. In cases where work should be performed in the status of power on, this manual always states to that effect.

To avoid an electric shock or short circuit, do not plug in or unplug quickly.

To avoid an electric shock, do not plug in or unplug with a wet hand.

Do not expose power cords or earth wires on the surface, (floor, passage, etc.) If exposed, the power cords and earth wires are susceptible to damage. Damaged cords and wires can cause an electric shock or short circuit.

To avoid causing a fire or an electric shock, do not put things on or damage the power cords.

When or after installing the product, do not unnecessarily pull the power in case the power cord is damaged, ask for a replacement through where the product was purchased from or the office herein stated. Using the cord as is damaged can cause fire, an electric shock or leakage.

Be sure to perform grounding appropriately. Inappropriate grounding can cause an electric shock.

Be sure to use fuses meeting the specified rating. Using fuses exceeding the specified rating can cause fire or an electric shock.

Be sure that connections such as IC BD are made properly. Insufficient insertion can cause an electric shock.

Specification changes, removal of equipment, conversion and/or addition, not designated by SEGA are not permitted.

Failure to observe this may cause a fire or an electric shock. Non-compliance with this instruction can have a bad influence upon physical conditions of the players or the onlookers, or result in injury during play.

SEGA shall not be held responsible for damage, compensation for damage to a third party, caused by specification changes not designated by SEGA.

Do not perform any work or change parts not listed in this manual. Doing so may lead to an accident. If you need to perform any work not listed in this manual, request work from the office indicated in this manual or the point of purchase, or inquire for details.

Be sure to perform periodic maintenance inspections herein stated.

IMPORTANT

For the IC board circuit inspections, only the use of a logic tester is recommended. Using a Multi Tester or General Purpose Tester may result in damage to IC Circuits.

Static electricity from your body may damage some electronics devices on the IC board. Before handling the IC board, touch a grounded metallic surface so that the static electricity can be discharged.

Some parts are not designed and manufactured specifically for this game Machine. The manufacturers may discontinue, or change the specifications of such general-purpose parts. If this is the case, SEGA cannot repair or replace a failed game machine whether or not a warranty period has expired.

CONCERNING THE STICKER DISPLAY

This SEGA product has stickers attached describing the product manufacturer No. (Serial No.) and Electrical Specifications. It also has a Sticker describing where to contact for repair and for purchasing parts.

When inquiring about or asking for repairs, mention the Serial No. and Name of Machine indicated on the Sticker. The Serial Number indicates the product register. Identical machines could have different parts depending on the date of production. Also, improvements and modifications might have been made after the publication of this manual. In order to ensure you order the correct parts, mention the Serial No. when contacting the applicable places.

CONCERNING WARNING DISPLAYS

This SEGA product has warning displays on stickers, labels and/or printed instructions adhered/attached to or incorporated in the places where a potentially hazardous situation could arise. The warning displays are intended for accident prevention for customers and for avoiding hazardous situations relating to maintenance and servicing work.

Some portions of the cabinet contain high voltage and may cause accidents if touched. When performing maintenance, be very careful of the warning displays. It is especially important that any complex repair and replacement work not mentioned herein should be performed by those technical personnel who have knowledge of electricity and technical expertise.

In order to prevent accidents, caution any customer ignoring the warnings to cease and desist immediately.

2. PRECAUTIONS REGARDING INSTALLATION

WARNING

This product is an indoor game machine. Do not install it outside. Even indoors, avoid installing in places mentioned below so as not to cause a fire, electric shock, injury and/or malfunction.

Places subject to rain or water leakage, or places subject to high humidity in the proximity of an indoor swimming pool and/or shower, etc.

Places subject to direct sunlight, or places subject to high temperatures in the proximity of heating units, etc.

Places filled with inflammable gas or vicinity of highly inflammable/volatile chemicals or hazardous matter.

Dusty places.

Sloped surfaces.

Places subject to any type of violent impact.

Vicinity of anti-disaster facilities such as fire exits and fire extinguishers.

Areas where the temperature exceeds the applicable temperature (ambient temperature) range of 5 to 30 degrees centigrade.

LIMITATIONS OF USAGE

WARNING

Be sure to check the Electrical Specifications. Ensure that this product is compatible with the location's power supply, voltage, and frequency requirements. A plate describing Electrical Specifications is attached to the product. Non-compliance with the Electrical Specifications can cause a fire and electric shock.

This product requires a breaker and earth mechanism as part of the location facilities. Using the product without these can cause a fire and electric shock.

Ensure that the indoor wiring for the power supply is rated at 15 A or higher (AC single phase 100 V ~ 120 V area), and 7 A or higher (AC 220 V ~ 240 V area). Non-compliance with the Electrical Specifications can a fire and electric shock.

Be sure to use an independent power supply equipped with an earth leakage breaker. Using a power supply without an earth leakage breaker can cause an outbreak of fire if a power surge occurs.

Putting many loads on one electrical outlet can cause generation of heat and a fire resulting from overload.

When using an extension cord, ensure that the cord is rated at 15 A or higher (AC 100 V ~ 120 V area) and 7 A or higher (AC 220 V ~ 240 V area). Using a cord rated lower than the specified rating can cause a fire and electric shock.

3. PRECAUTIONS REGARDING OPERATION

IMPORTANT

Securing a safe area for operation as described in this manual will ensure safe operation for players and observers.

SEGA shall not be held responsible for damage or compensation for damage to a third party, resulting from the failure to observe this instruction.

OPERATION AREA (SINGLE CABINET)

WARNING

For the operation of this machine, please secure a minimum area of 2.10m (D) and 1.10m (W)

Be sure to provide sufficient space specified in this manual. Do not allow objects to block ventilation ports. It can cause generation of heat and a fire.

Sufficient space either side of the playing area must be allowed for the player to enter or exit the game play area safely.

4. LOCATIONS:

NOTICE

THE MACHINE IS DESIGNED FOR INDOOR USE ONLY. NEVER INSTALL THIS MACHINE OUTDOORS OR IN ANY OF THE FOLLOWING:

- LOCATIONS EXPOSED TO DIRECT SUNLIGHT.
- LOCATIONS SUBJECT TO RAIN OR WATER LEAKAGE.
- UNSTABLE LOCATIONS OR LOCATIONS SUBJECT TO VIBRATION.
- DUSTY, HOT, OR DAMP LOCATIONS.

4-1 GAME LEVELING:

INSTALL THIS MACHINE ON A FLAT SURFACE. ADJUST LEVELERS TO LIFT THE LEGS AND LEVEL GAME.

MAKE SURE THAT THE MACHINE IS LEVEL WITH THE FLOOR. IF THE MACHINE IS NOT LEVEL, THE GAME MAY NOT FUNCTION CORRECTLY.

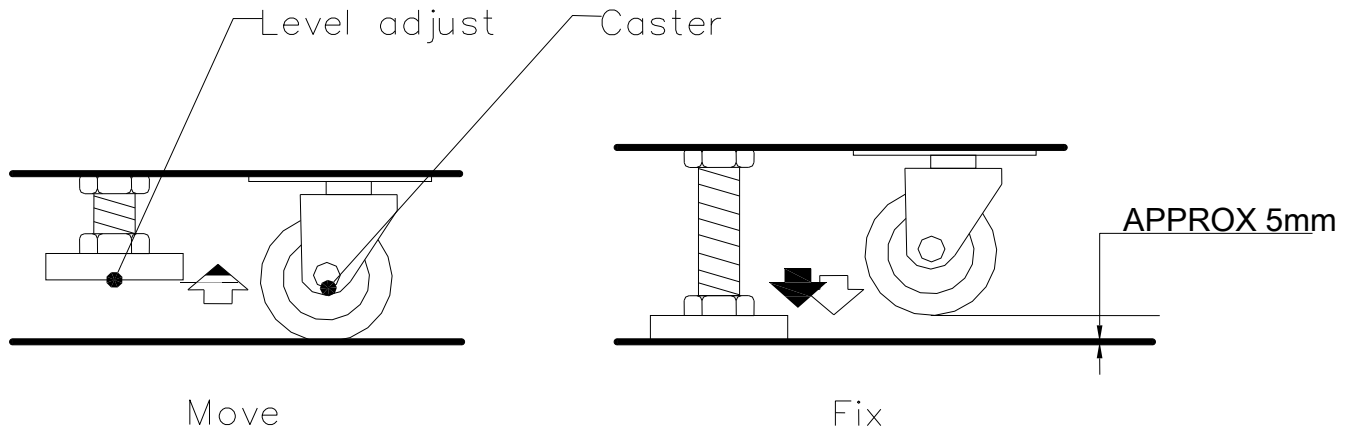

WARNING

- DISCONNECT GAME POWER BEFORE MOVING
- MAKE SURE ALL WHEELS ARE INTACT. REPLACE ANY WHEELS THAT ARE DAMAGED OR BROKEN BEFORE MOVING THE GAME.
- WHEN MOVING THE GAME, DO NOT SLIDE THE GAME ACROSS THE FLOOR
- ENSURE THE GAME IS LEVEL BEFORE CONNECTING THE POWER

5. GAME DESCRIPTION

OVERALL DIMENSIONS and APPEARANCE;



6. GAME SET UP AND ADJUSTMENTS / TEST FUNCTIONS

6-1 GAME MENU and OPTIONS SETTINGS

Menu & Game Options Adjustments Panel

The Game Menu and Adjustments are accessed through the center coin door and located on a small, COINS, TICKETS and CAPSULES meter panel where three pushbuttons are found; "MENU", "OPTION" and "TICKET CLEAR". These pushbuttons are used to access a specific function MENU and change a game settings Option or Test function within a directory of selections, factory default settings, and/or custom settings according to the game manual. These adjustments are shown in the game 7 segment, SCORE LED display on the marquee panel once the "MENU" button has been pressed by the Operator during non-game play periods.

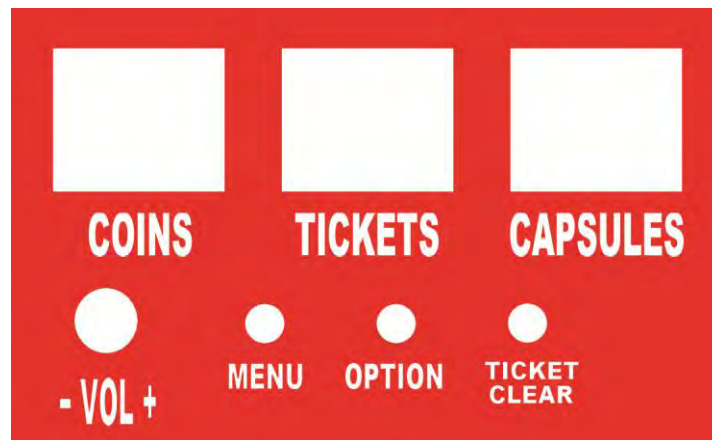

Menu & Game Options Adjustments

The game adjustment settings, by entering the MENU, [pressing the MENU button inside the coin door], are displayed in the 3 block, 7 segment, LED display [Score/Jackpot Display].

When an Operator presses the "MENU" pushbutton located inside the coin door- the display changes to display the MENU# and the OPTION# setting within the directory outlined below. By continuing to depress the MENU pushbutton, the Operator may advance through the various MENU #s in order to reach a specific MENU for adjustment. Once a specific MENU is displayed, the Operator uses the OPTION pushbutton to change the various OPTION #s available within that Menu.

Continued on the next page;

Menu & Game Options Adjustments [Displayed on the LED Display]

The first 2 digits are the; **MENU #**.

The second digit is the; **OPTION #**.

Advancing through the MENU selections back to -0-0-0 will save the selections and return the game to normal after 2 seconds.

The "TICKET CLEAR" button is used to clear any unpaid tickets stored in memory when a new bundle of tickets has been installed.

Turning the Power OFF and then ON again will save the game parameters within the software.

MENU and OPTIONs Directory

MENU # OPTION#

00 0

Score Display

***Denotes Factory Default settings at the factory**

MENU#	OPTION#	ACTION
00	0	Return to Game Play
01	0	Free Play
01	1	1 Credit Play
01	2 *	2 Credit Play
01	3	3 Credit Play
01	4	4 Credit Play
02	0	Round of Play 8 seconds (x3)
02	1*	Round of Play 10 seconds (x3)
02	2	Round of Play 12 seconds (x3)
02	3	Round of Play 14 seconds (x3)
02	4	Round of Play 16 seconds (x3)
02	5	Round of Play 18 seconds (x3)

MENU#	OPTION#	ACTION
03	0	Ticket mechanism disabled- no tickets - OFF
03	1*	Ticket mechanism enabled – ON
04	0*	Ticket value - 1 pt.
04	1	Ticket value - 2 pt.
05	0	Attract OFF
05	1	Attract every 15 seconds
05	2*	Attract every 30 seconds
05	3	Attract every 45 seconds
05	4	Attract every 60 seconds
05	5	Attract every 90 seconds
05	6	Attract every 120 seconds
06	0	Attract Audio OFF
06	1*	Attract Audio ON
07	0	Zombies per round – Lowest [Zombies time out @ 1 sec.]
07	1*	Zombies per round – Low [Zombies time out @ .75 sec.]
07	2	Zombies per round – Medium [Zombies time out @ .5 sec.]
07	3	Zombies per round – Maximum [Zombies time out @ .25 sec.]
08	0	Jackpot –DISABLED [Capsule dispensed at perfect score if MENU 11-1 enabled]
08	1	Jackpot fixed amount: 20

MENU#	OPTION#	ACTION
08	2*	Jackpot fixed amount: 30
08	3	Jackpot fixed amount: 40
08	4	Jackpot fixed amount: 50
08	5	Jackpot fixed amount: 60
08	6	Jackpot fixed amount: 70
08	7	Jackpot fixed amount: 80
08	8	Jackpot fixed amount: 90
08	9	Jackpot fixed amount: 100
09	0	1 ticket per 2 Zombies hit
09	1	1 ticket per 3 Zombies hit
09	2*	1 ticket per 4 Zombies hit
09	3	1 ticket per 5 Zombies hit
09	4	1 ticket per 6 Zombies hit
09	5	1 ticket per 7 Zombies hit
09	6	1 ticket per 8 Zombies hit
09	7	1 ticket per 9 Zombies hit
09	8	1 ticket per 10 Zombies hit
10	0	Mercy ticket- OFF
10	1*	Mercy ticket – 1
10	2	Mercy ticket – 2
10	3	Mercy ticket – 3
10	4	Mercy ticket – 4
10	5	Mercy ticket – 5
10	6	Mercy ticket – 6

MENU#	OPTION#	ACTION
11	0*	Capsule Vendor – DISABLED
11	1	Capsule Vendor - ENABLE

6-2 TEST FUNCTIONS

MENU#	OPTION#	ACTION
TEST FUNCTIONS:		[Most Tests confirmed by an audio “Ding” Bell Tone (sfx) when actuated by hand]
12	0	Test: Audio- play background main1
12	1	Test: All Zombie OPTO detect- “ding” sfx.
12	2	Test: Zombie coil mechanisms; #1 - #6 in sequence one at a time actuate UP and DOWN one time. >“ding” sfx.
12	3	Test: Score, Jackpot, Time Display – flash all.
12	4	Test: All LED character rings – flash all.
12	5	Test: Capsule vendor-dispense ONE [enabled]
12	6	Test: Capsule dispense opto detect >“ding” sfx.
12	7	Test: Ticket mechanism run
12	8	Test: Coin mechanism switches- “ding” sfx.

7. COIN HANDLING

7-1 INSTRUCTION FOR ELECTRONIC COIN COMPARATOR TYPE



A. REMOVE THE PLASTIC COIN FROM COIN SLOT, REPLACE WITH THE DESIRED TOKEN OR COIN INSIDE THE SPRING TENSIONED COIN HOLDER.

B. LOOSEN BOLTS AT THE BACK OF COIN ENTRANCE. USE THE DESIRED COIN DIAMETER TO ADJUST SPACE AT THE BACK OF COIN ENTRANCE. AVOID ERROR CAUSED BY LARGE DIAMETER TOKENS.

C. ADJUST FOR GAME MAIN BOARD PULSE RATE NEEDS. CHOOSE COIN LONG SHORT AND FAST SLOW THREE PHASE SWITCH (TIMER SWITCH) : 30MS IS SHORT FAST SIGNAL BEST FOR MACHINES THAT HAVE HIGH POWER AND REQUIRES THE INSERT OF COINS QUICKLY, 50MS IS MIDDLE SIGNAL, BEST FOR ORDINARY MACHINES (IF NOT SPECIAL CIRCUMSTANCE, THE MACHINE USUALLY CAN USE THIS PHASE). 100MS IS LONG, SLOW SIGNAL, BEST FOR MACHINES THAT DO NOT NEED COINS INSERTED QUICKLY.

D. VR COIN CHOICE SENSITIVITY ADJUSTMENT. ANTICLOCKWISE ADJUSTMENT (—) , ACCEPT SMALLER AREA OF COIN TOLERANCE, COIN TYPE FILTRATION WILL BE MORE RESTRICTED.

Wiring :

- Grey —————
- Red -DC+12V
- White —COIN signal
- Black-Grounded
- Grey —————

Code Table

8. TICKET MECHANISM

8-1 INSTALLING TICKETS:

1. AS SHOWN ON PICTURE1, PUSH THE METAL BLOCK UP AND LIFT THE ALUMINUM PLATE;
2. FEED THE TICKET THROUGH THE INSPECTING SENSOR UNTIL THEY REACH THE ROLLER AND INSTALL THE TICKET.
3. PRESS THE "RESET" BUTTON TO ADVANCE THE TICKETS THROUGH THE ROLLER.
4. INSTALL THE ALUMINUM PLATE BACK IN PLACE;
5. WHEN ALL TICKETS HAVE BEEN DISPENSED, AND AN UNPAID BALANCE IS HELD IN THE GAME MEMORY, PRESS THE "JP CLEAR" BUTTON ON THE MENU & ADJUSTMENT PANEL INSIDE THE COIN DOOR AREA TO DISPENSE REMAINING BALANCES. THIS WILL CLEAR ANY UNPAID TICKETS FROM MEMORY.

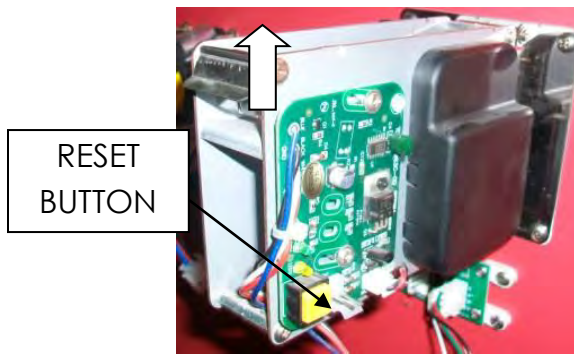

PICTURE 1



PICTURE 2

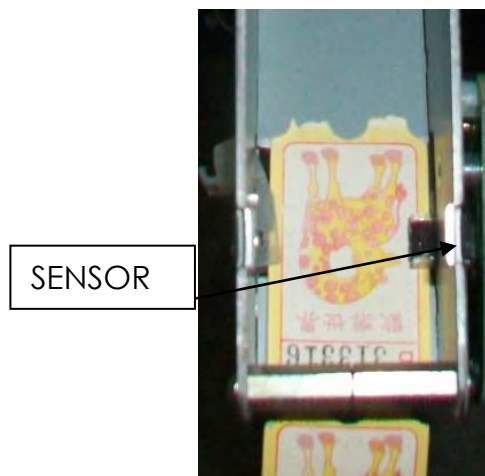

PICTURE 3



PICTURE 4



PICTURE 5

9. ELECTRONIC COMPONENTS

9-1 MAIN BOARD

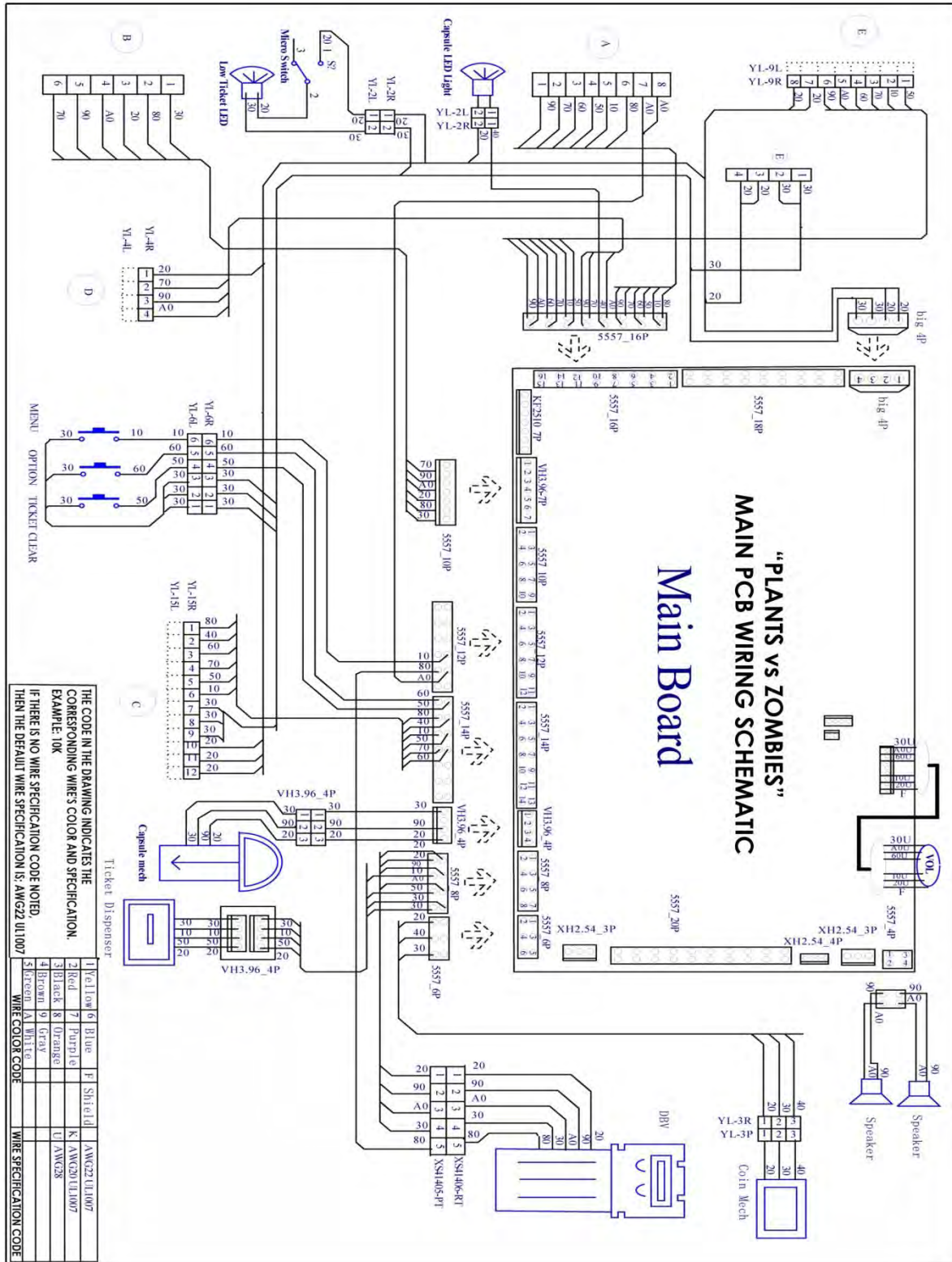

9-2 MAIN BOARD I/O

No.	Part	I/O BOARD Detail								
J2	Output	I/O Port	OUT10	OUT12	OUT14	OUT16	OUT18	OUT20	OUT22	OUT24
		Function	Zombie 2 Jump Signal	Zombie 4 Jump Signal	Zombie 6 Jump Signal	Capsule Indicator Light	Ticket Meter	Zombie 2 Jump Out Warning Light	Zombie 4 Jump Out Warning Light	Zombie 6 Jump Out Warning Light
		I/O Port	OUT9	OUT11	OUT13	OUT15	OUT17	OUT19	OUT21	OUT23
		Function	Zombie 1 Jump Signal	Zombie 3 Jump Signal	Zombie 5 Jump Signal	Jackpot Meter	Coin Meter	Zombie 1 Jump Out Warning Light	Zombie 3 Jump Out Warning Light	Zombie 5 Jump Out Warning Light
J5	LED	I/O Port	MISO	MOSI	SS	SCK	12V	5V	GND	
		Function	Not Used	LED Signal 1	LED Signal 2	LED Signal 3				
J7	Input	I/O Port	IN10	IN12	IN14	IN16	VCC	GND		
		Function				Menu Button	Power Board Drive Power			
		I/O Port	IN9	IN11	IN13	IN15	VCC	GND		
		Function					DBV Drive Power			
J8	Input	I/O Port	IN18	IN20	IN22	IN24	VCC	VCC	GND	
		Function	Ticket Clear Button	Score Sensor 1	Score Sensor 4	Score Sensor 5				
		I/O Port	IN17	IN19	IN21	IN23	VCC	VCC	GND	
		Function	Option Button	Score Sensor 2	Score Sensor 3	Score Sensor 6				
J12	Meter Output Socket	I/O Port	GND	METER2	METER1	12V				
		Function	Capsule Mech Power -		Capsule Drive Signal	Capsule Mech Power +				
JP2	Ticket Dispenser Socket	I/O Port	12V	COINC1	COIN1	GND				
		Function	DBV Power +	DBV Drive	DBV Feedback	DBV Power -				
		I/O Port	12V	COINC1	COIN1	GND				
		Function	Ticket Dispenser Power +	Ticket Dispenser Drive	Ticket Dispenser Feedback	Ticket Dispenser Power -				
J3	Coin Selector Socket	I/O Port	12V	COIN2	DND					
		Function								
		I/O Port	12V	COIN1	DND					
		Function	Coin Selector Power +	Coin Signal	Coin Selector Power -					

9-3 EXTENSION BOARD I/O LIST

No.	Part	EXTENSION BOARD Detail								
		I/O Port	AC24	AC24			AC12	AC12		
JP1	Input	I/O Port	AC24	AC24			AC12	AC12		
		Function	Power Board AC24V	Power Board AC24V			Power Board AC12V	Power Board AC12V		
J3	Input	I/O Port	5V	5V	OUT6	OUT5	OUT4	OUT3	OUT2	OUT1
		Function	Zombie Jump Drive Power	Zombie Jump Drive Power	Zombie 6 Jump	Zombie 5 Jump	Zombie 4 Jump	Zombie 3 Jump	Zombie 2 Jump	Zombie 1 Jump
J2	Output	I/O Port	GND	GND	12V	12V				
		Function	Decoration Light Power -	Decoration Light Power -	Decoration Light Power +	Decoration Light Power +				
J1	Output	I/O Port	35V-1	C1	35V-2	C2	35V-3	C3	35V-4	C4
		Function	Zombie Jump Drive 1	Zombie Jump Drive 1+	Zombie Jump Drive 2	Zombie Jump Drive 2+	Zombie Jump Drive 3	Zombie Jump Drive 3+	Zombie Jump Drive 4	Zombie Jump Drive 4+
		I/O Port	35V-5	C5	35V-6	C6				
		Function	Zombie Jump Drive 5	Zombie Jump Drive 5+	Zombie Jump Drive 6	Zombie Jump Drive 6+				

4	5	6
1	2	3

GAME MACHINE ZOMBIE COIL SEQUENCE REFERENCE

9-4 WIRING DIAGRAMS

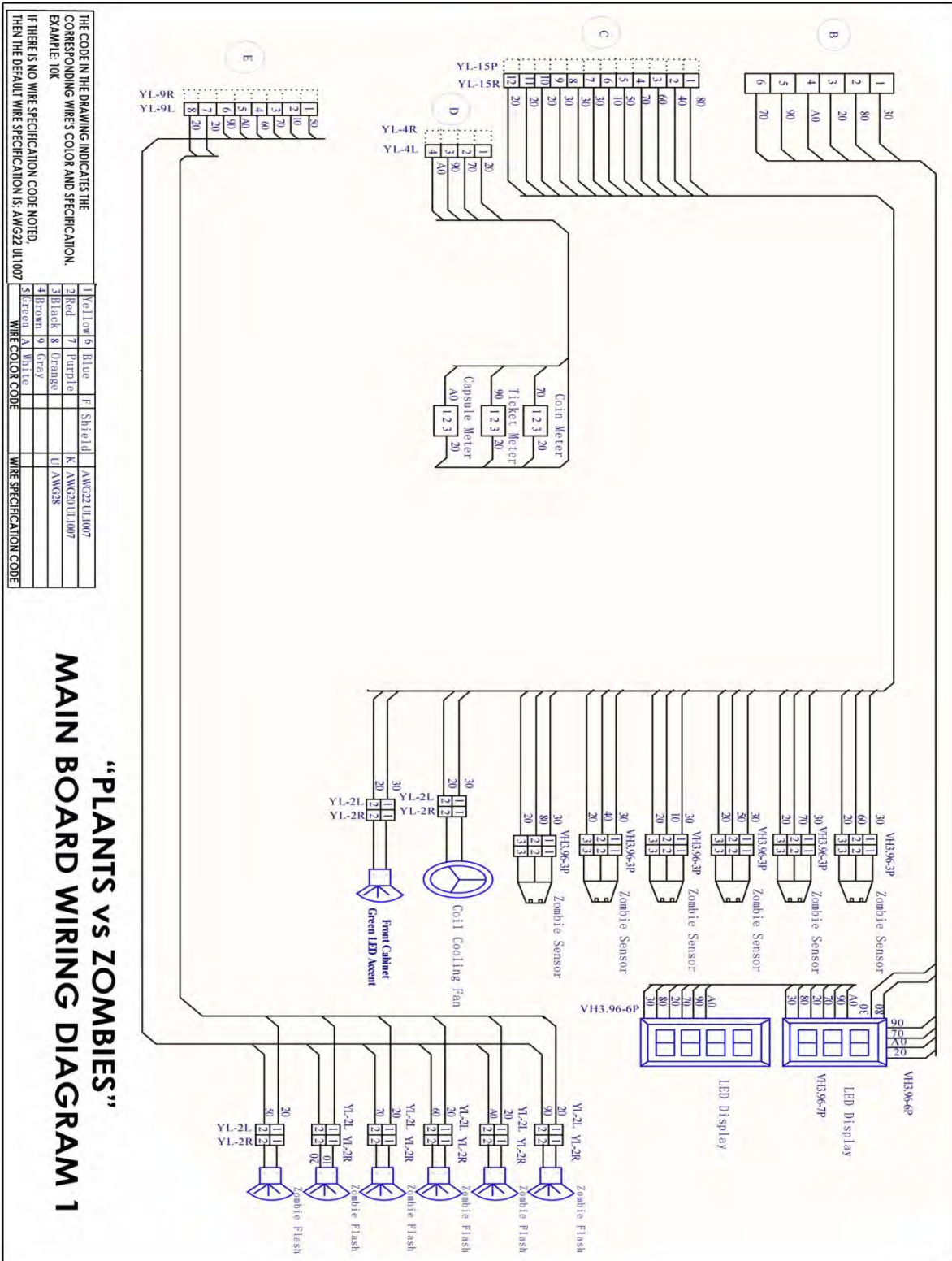

9-5 WIRING DIAGRAMS CONTINUED

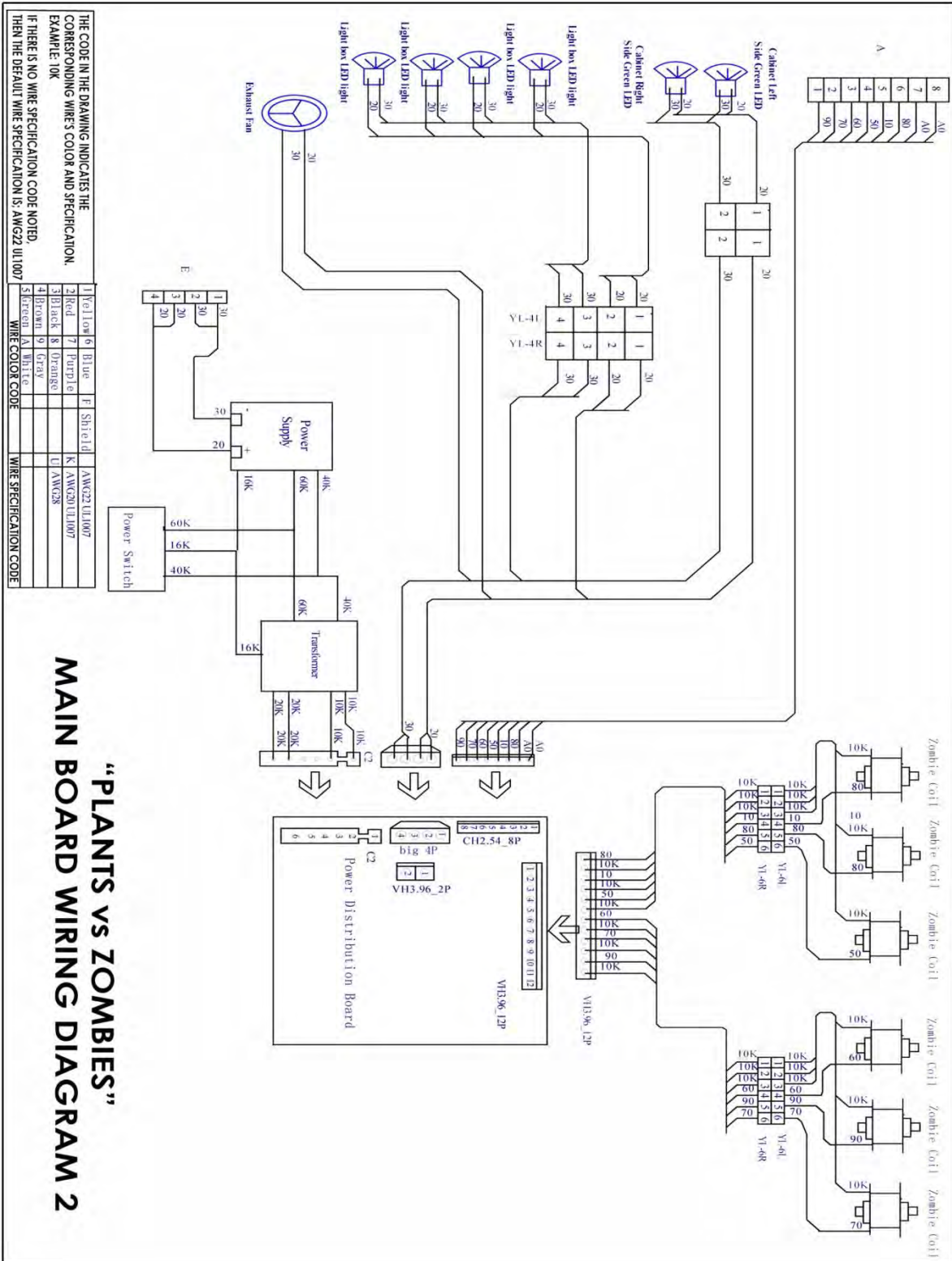

9-6 COIL BED ASSEMBLY

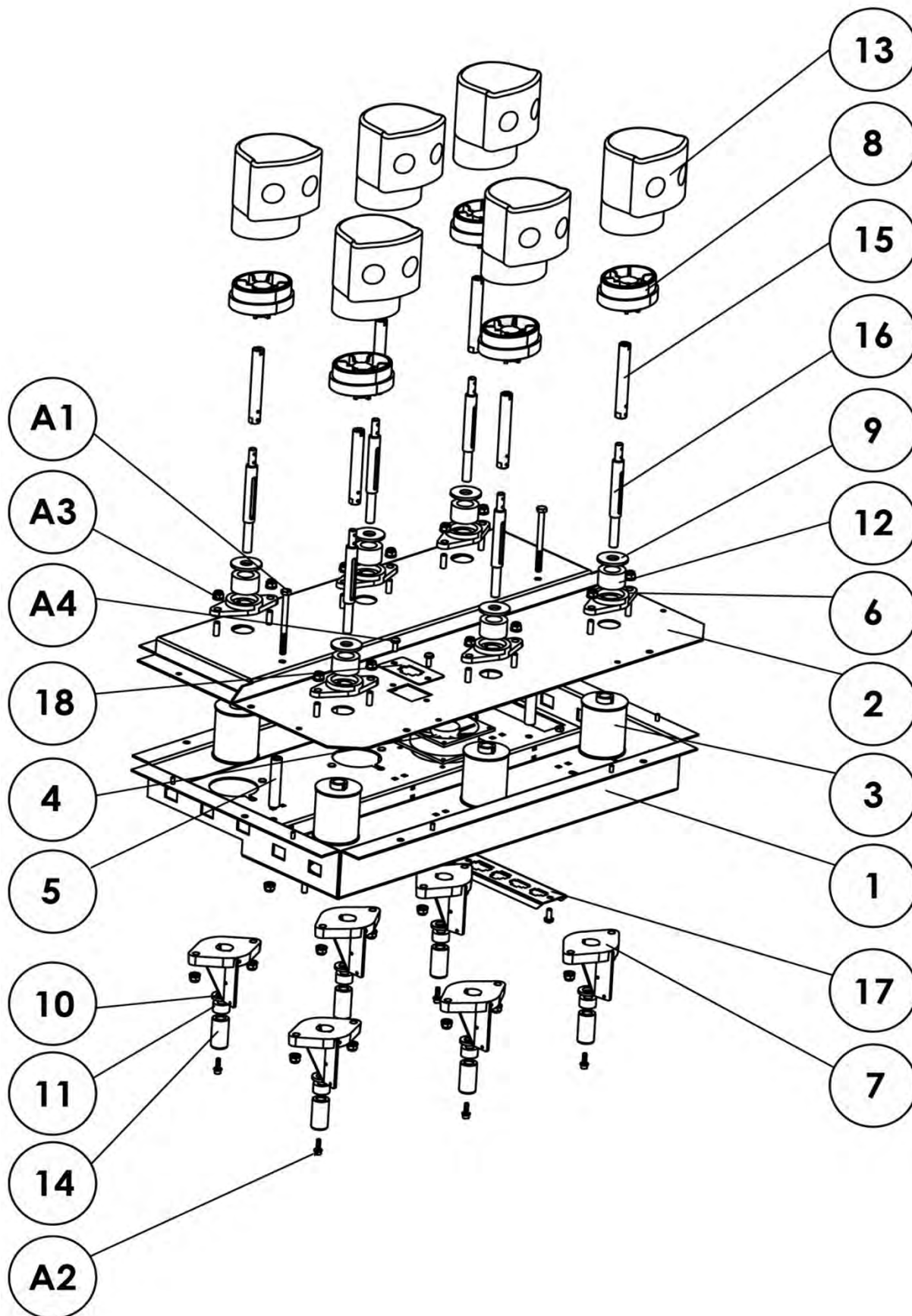

PvZ Zombie Coil Bed Mechanism Assembly Drawing

NO.	Part's Name	Material	Quantity
A4	M4X15		4
A3	M6		24
A2	M5X15		6
A1	M6X80		2
18	Socket Panel 2	Stainless Steel	1
17	Socket Panel 1	Stainless Steel	1
16	Coil Core	DT8	6
15	Coil Shaft	Aluminum	6
14	Sensor Cover	Aluminum	6
13	Zombie Character	PVC	6
12	Upper Shockproof Rubber	NBR	6
11	Bottom Shockproof Rubber	NBR	6
10	Upper Ring	ABS	6
9	Bottom Ring	ABS	6
8	Zombie Seat	ABS	6
7	Coil Bottom Holder	ABS	6
6	Coil Upper Holder	ABS	6
5	Connecting Pole	Q235	2
4	Fan		1
3	Coil		6
2	Upper Panel	Q235	1
1	Bottom Panel	Q235	1

9-7 GAME ASSEMBLY

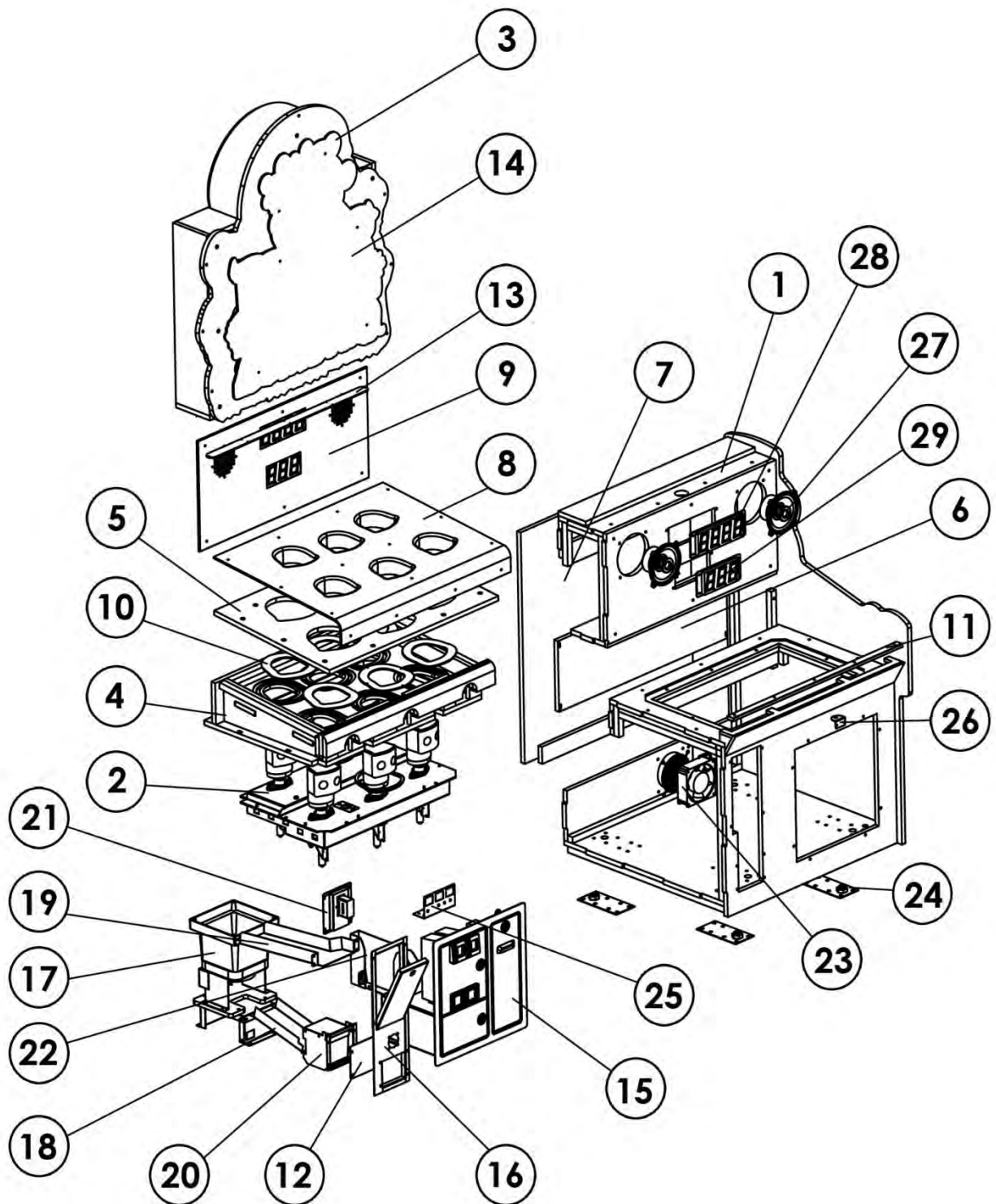

PvZ Machine General Assembly Drawing			
NO.	Part's Name	Material	Quantity
29	3 Digit LED Display		1
28	4 Digit LED Display		1
27	Speaker		2
26	Mallet Rope Ring	Stainless	1
25	Meter Panel		1
24	Castor Metal Panel		4
23	Fan & Grill Cover		1
22	Ticket Bin		1
21	Power Socket		1
20	Capsule Box		1
19	Capsule Slide Entry	Q235	1
18	Capsule Slide Exit	Q235	1
17	Capsule Mechanism		1
16	Capsule Door	Q235	1
15	Triple Door	Q235	1
14	Header Front Graphic	Acrylic Silk Screen	
13	Display Panel LED Light		1
12	Capsule Door Cover Panel	Blue PVC	1
11	Playfield Front LED Light	Acrylic	1
10	Zombie Light	Acrylic	6
9	Display panel Graphic	Acrylic Silk Screen	1
8	Playfield Cover Panel	Vacuum PVC	1
7	Back Door Board	Plywood	1
6	PCB Board Mounting	Plywood	1
5	Zombie Base Wooden Frame Cover	Plywood	1
4	Zombie Base Wooden Frame	Plywood	1
3	Header Cabinet	Plywood	1
2	Zombie Coil Bed Assembly		1
1	Wooden Cabinet	Plywood	1

10. ERROR CODES

ERROR CODES ARE DISPLAYED IN THE SCORE AND JACKPOT DISPLAY

PvZ Game Error Code Description

Error Code	Description	Solution
E-01	Coin Mech error	<ol style="list-style-type: none"> 1. Check the mechanism for jammed coins and clear the coin path. 2. Repair or replace the Coin Mech.
E-02	Ticket Dispenser error	<ol style="list-style-type: none"> 1. Check the mechanism for jammed tickets and whether tickets move freely by advancing the tickets. 2. The game is out of tickets and needs to be refilled. After reloading tickets, press the "Ticket Clear" button to dispense all tickets held in memory. 3. Repair or replace the Ticket Dispenser.
E3C1	The 1st Zombie Sensor error	<ol style="list-style-type: none"> 1. Disconnect the corresponding Zombie Sensor wire, check for proper fit and connect it well again. 2. Repair or replace the corresponding Zombie Sensor
E3C2	The 2nd Zombie Sensor error	
E3C3	The 3rd Zombie Sensor error	
E3C4	The 4th Zombie Sensor error	
E3C5	The 5th Zombie Sensor error	
E3C6	The 6th Zombie Sensor error	
E4C1	The 1st Zombie Coil error	<ol style="list-style-type: none"> 1. Disconnect the corresponding Zombie Coil wire, check for proper fit and connect it well again. 2. Repair or replace the corresponding Zombie Coil.
E4C2	The 2nd Zombie Coil error	
E4C3	The 3rd Zombie Coil error	
E4C4	The 4th Zombie Coil error	
E4C5	The 5th Zombie Coil error	
E4C6	The 6th Zombie Coil error	
n.o.t.	Out of ticket message in LED	Install new tickets

NOTE: After resolving the Error Code issue, power off, and then power on the machine again. The Error Code should be cleared.

11. COIL BED SERVICE AND MAINTENANCE

11-1 ACCESSING THE COIL BED:

1. Remove the 15 pcs, security bolts and cup washers that hold the playfield cover panel. Carefully remove the panel by lifting straight up and over the Zombie PVC Characters.



2. Remove the 12 pcs, bolts on the Zombie Base Wooden Frame Cover, then lift off this wooden cover.



3. Remove the 8 pcs, bolts that are holding the Zombie Base Wooden Frame. Lift off and remove this wooden frame.



4. Remove the 8 pcs, bolts that are holding the Zombie Coil Bed Assembly to the cabinetry. . you can now safely transfer the entire Zombie Coil Bed Assembly for service or replacement.



5. For removing one or all of the Zombie individual coil units, remove this center hex bolt(s) in the center base of each of the Zombies.

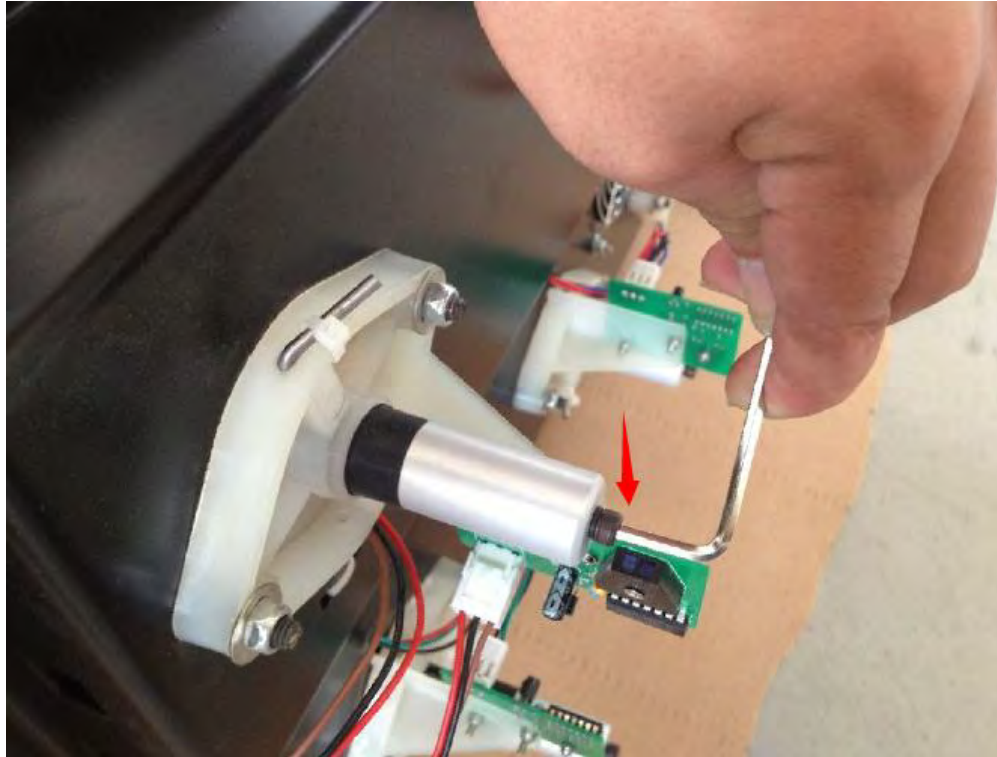

6. Carefully cut the wire tie & remove the key pin which will allow you to remove the Zombie Character and shaft.



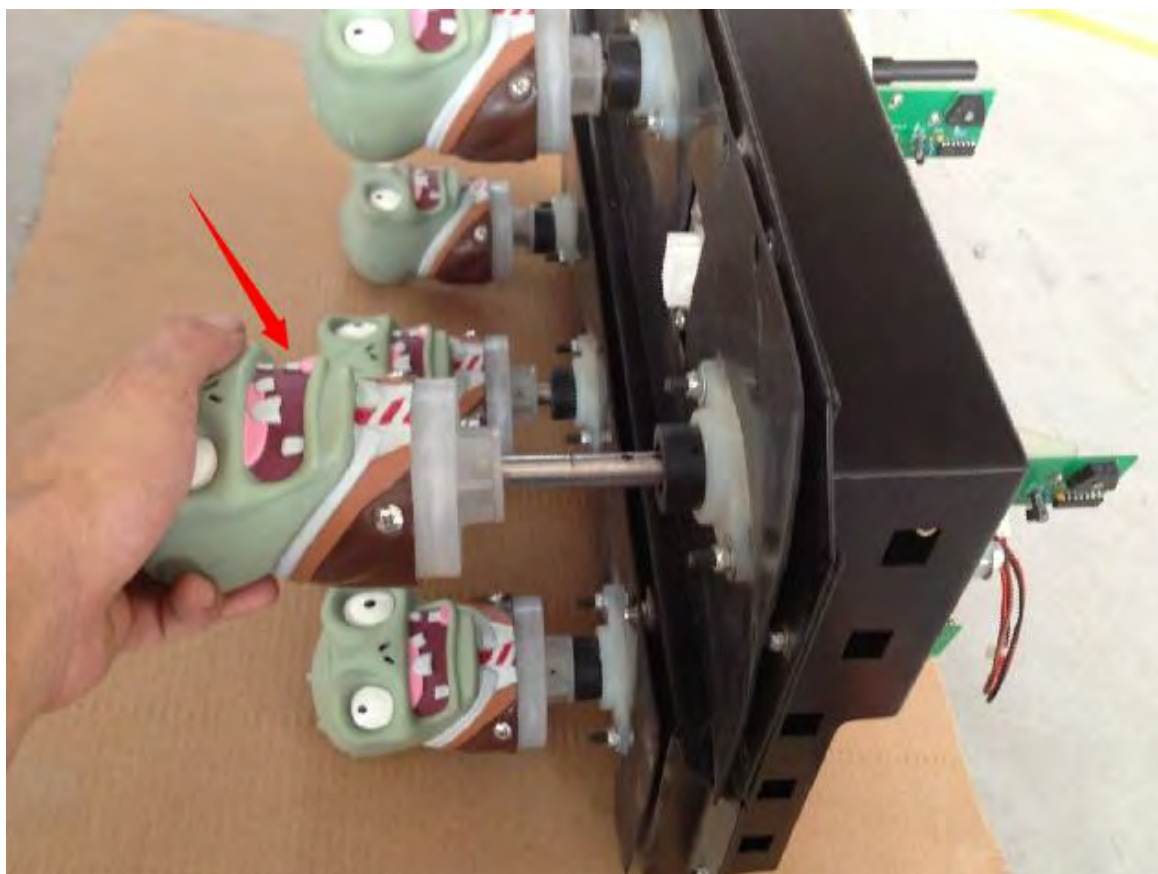
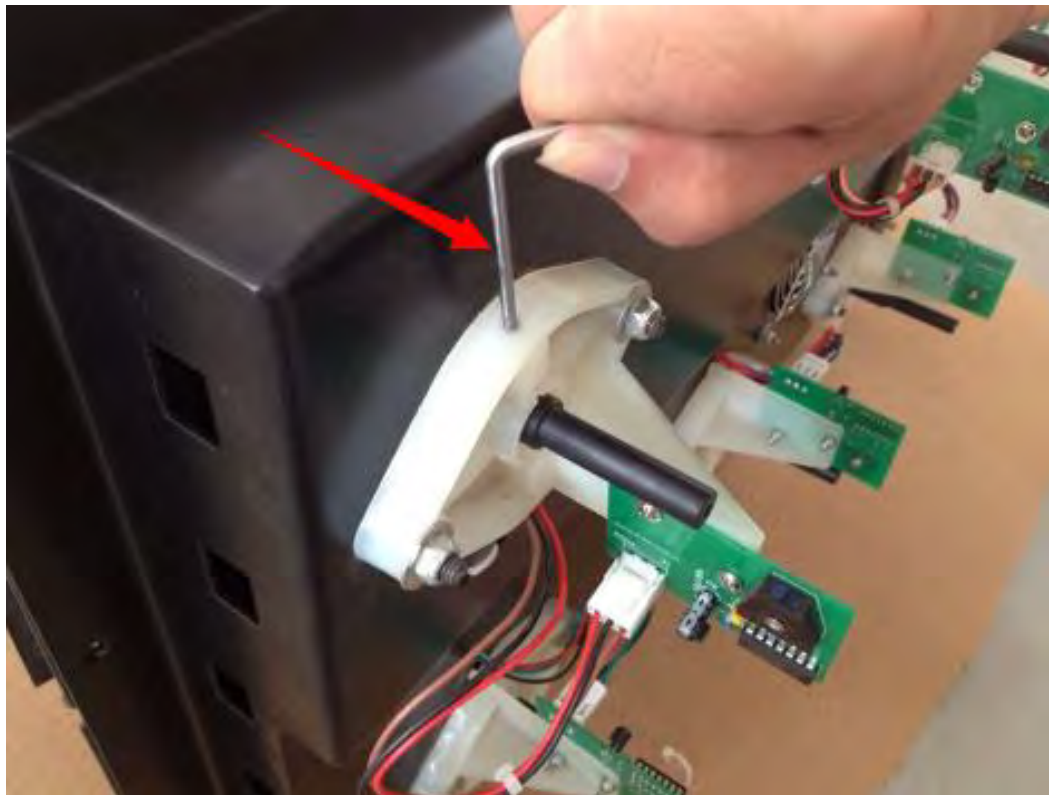

7. Use a 7mm Hexagon Socket wrench to remove the 8 hex bolts as pictured below on the Zombie Assemble Set.

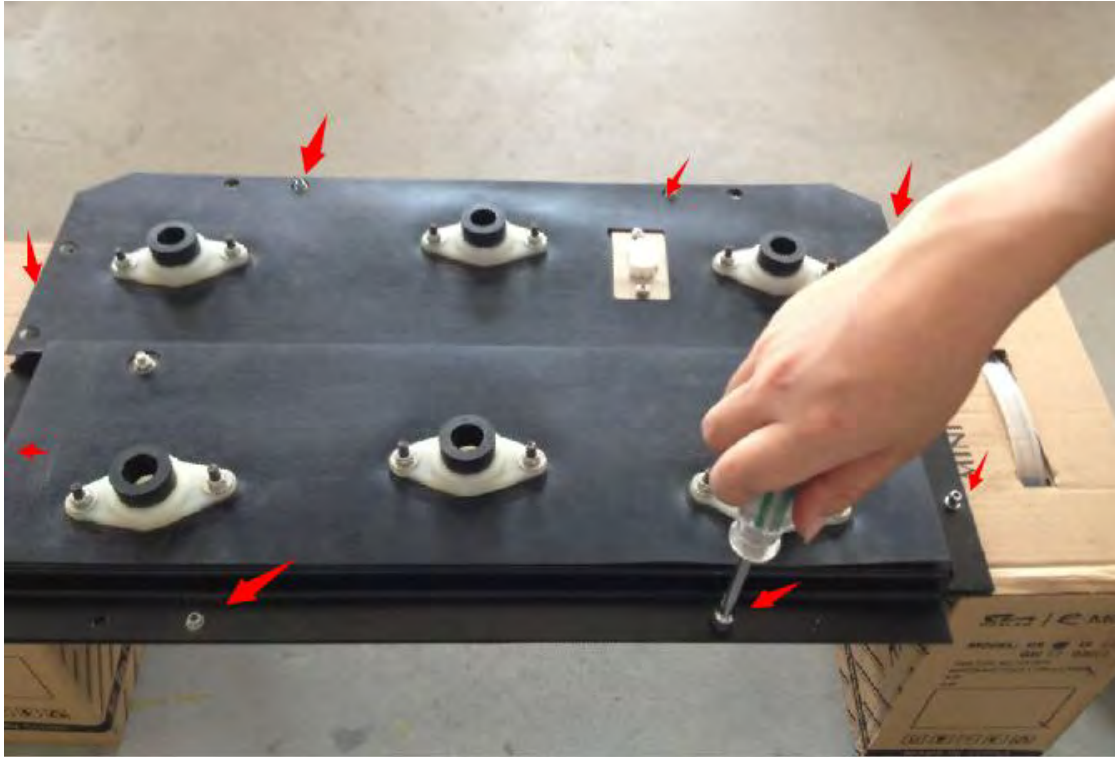

8. In 2 places use a 10mm Hexagon Socket wrench to remove the 2 bolts as pictured below on the Zombie Coil Bed Assembly Set.

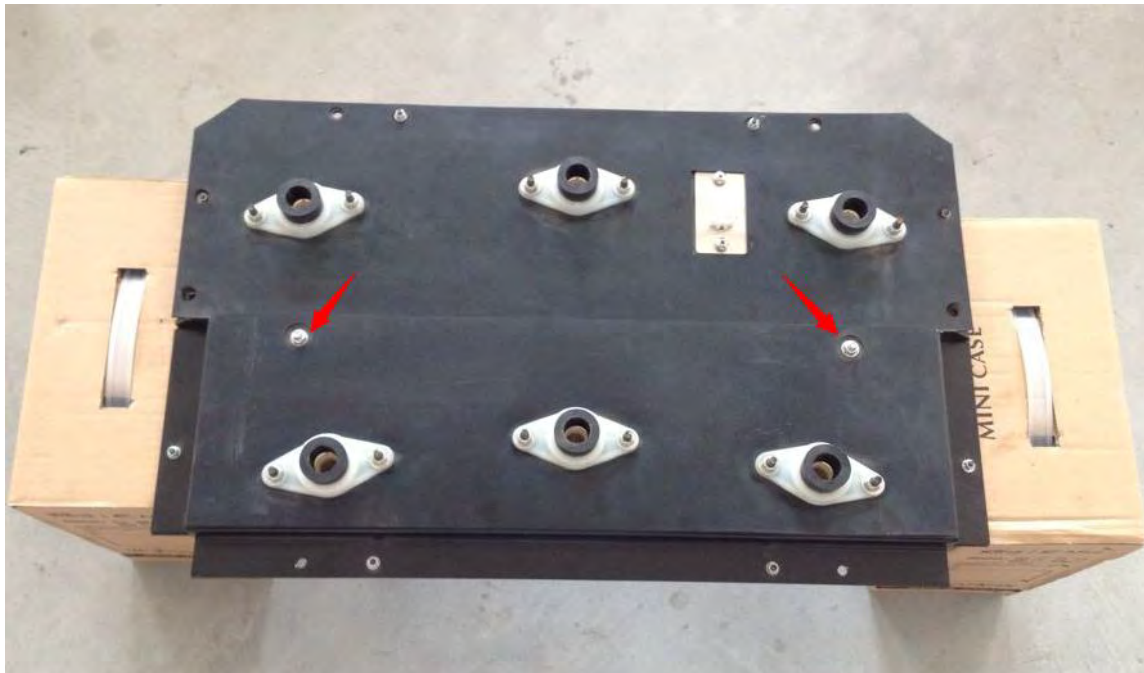

9. After removing the metal cover, open the Coil Bed Metal Box, disconnect the wire connector, and remove the Coil Bed.

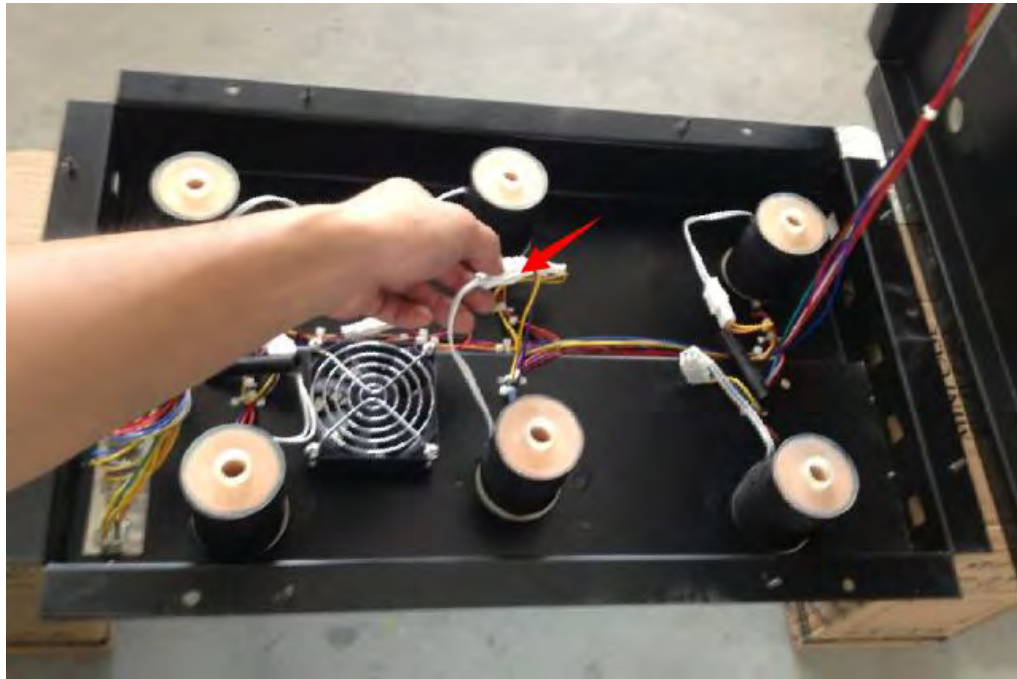

10. Assemble in reverse order after making any necessary repairs or replacement.

11. HEADER LIGHT BOX SERVICE AND MAINTENANCE

11-2 TO REMOVE THE HEADER LIGHT BOX ASSEMBLY

1. Using a 10mm Hexagonal Socket wrench, remove 4 bolts as pictured below from inside the base cabinet through the back service door and below the header graphic light box. Disconnect the wire connector as shown, and then remove the whole header graphic light box assembly from the base.



TO SERVICE THE HEADER LIGHT BOX LED LIGHTING;

1. Remove all of the 13 security bolts in the locations shown below. Remove the Header Graphics panel.



2. Remove the bolts from the straps that are holding the LED Light strips in place. You can then remove the LED Light strips for replacement or service.

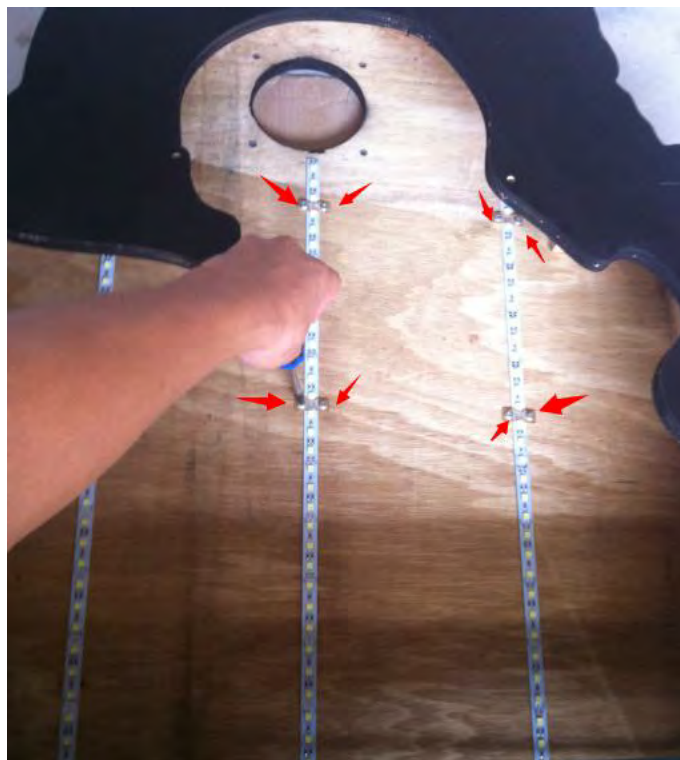

12. PARTS DESCRIPTION

12-1 CABINET GRAPHICS & LABELS



MASTER WARNING LABELS



FUSE RATING ID LABELS



110-120V/ AC VERSION



220-240V VERSION



MARQUEE HEADER (2 PC.)

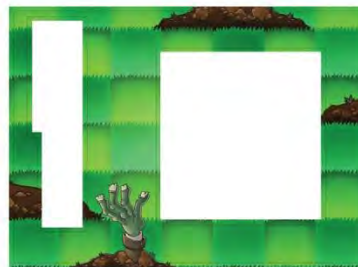

CABINET FRONT PANEL



SPEAKER/ DISPLAY PANEL

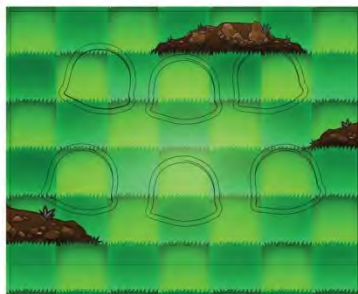

PLAYFIELD COVER









CABINET RIGHT SIDE





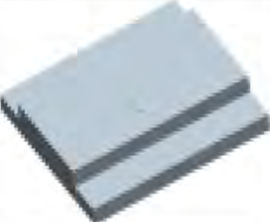





CABINET LEFT SIDE









12-2 PARTS LIST



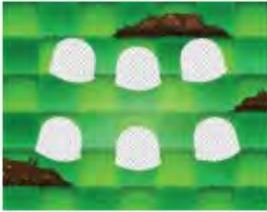





Part No.	Part's Name	Material / Specification	Image	Qty	Unit
PvZ-001	Wooden Cabinet	Plywood		1	Set
PvZ-002	Back Door	Plywood		1	Pc
PvZ-003	Zombie Holes Seat Board	Plywood		1	Set
PvZ-004	Playfield Cover Panel	Plywood		1	Pc
PvZ-005	Header Cabinet	Plywood		1	Set
PvZ-006	Platform for Transformer	Plywood		1	Pc
PvZ-007	Wooden Board for Mounting Main Board	Plywood		1	Pc

PvZ-008	Protection Board for Header Graphic	Plywood		1	Pc
PvZ-009	Bottom Panel	Black Coated Metal		1	Pc
PvZ-010	Upper Panel	Black Coated Metal		1	Pc
PvZ-011	Capsule Door	Green Coated Metal		1	Pc
PvZ-012	Capsule Stock Chute	Black Coated Metal		1	Pc
PvZ-013	Capsule Output Chute	Black Coated Metal		1	Pc
PvZ-014	Meter Panel	Black Coated Metal		1	Pc
PvZ-015	Mallet Rope Ring	Stainless Steel		1	Pc









PvZ-016	Socket Panel 1	Stainless Steel		1	Pc
PvZ-017	Socket Panel 2	Stainless Steel		1	Pc
PvZ-018	Header LED Light Panel	Stainless Steel		2	Pc
PvZ-019	Ticket Bin	Black Coated Metal		1	Pc
PvZ-020	Castor Metal Panel	Black Coated Metal		4	Pc
PvZ-021	Triple Door	Green Coated Metal		1	Pc
PvZ-022	Ticket Dispenser Fixing Panel	Black Coated Metal		1	Pc
PvZ-023	Power Socket Panel	Black Coated Metal		1	Pc

PvZ-024	Zombie Right Angel Key	Iron		6	Pc
PvZ-025	Connecting Pole	Black Coated Metal		2	Pc
PvZ-026	Sensor Cover	Aluminum		6	Pc
PvZ-027	Coil Shaft	Aluminum		6	Pc
PvZ-028	Coil Core	Aluminum		6	Pc
PvZ-029	Mallet Rope Cover Rubber	POM		1	Pc
PvZ-030	Capsule Door Cover Panel	Green Coated Metal		1	Pc
PvZ-031	Header Back Graphic	Acrylic Silk Screen Print		1	Pc

PvZ-032	Header Front Graphic	Acrylic Silk Screen Print		1	Pc
PvZ-032	Display Panel Graphic	Acrylic Silk Screen Print		1	Pc
PvZ-033	Playfield Cover Panel Graphic	Adhesive Silk Screen Print		1	Pc
PvZ-034	Left Side Cabinet Graphic	Adhesive Silk Screen Print		1	Pc
PvZ-035	Right Side Cabinet Graphic	Adhesive Silk Screen Print		1	Pc
PvZ-036	Front Door Graphic	Adhesive Silk Screen Print		1	Pc
PvZ-037	Meter Panel Graphic	Adhesive Silk Screen Print		1	Pc
PvZ-038 VERSION 220V	Serial No. Label -UK	Adhesive Silk Screen Print		1	pc

PvZ-038 VERSIO N 110V	Serial No. Label -USA	Adhesive Silk Screen Print		1	pc
PvZ-039	Caution Label	Adhesive Silk Screen Print		1	pc
PvZ-040	Electric Warning Label	Adhesive Silk Screen Print		1	pc
PvZ-041	Power Warning Label 220-240V VERSION	Adhesive Silk Screen Print		1	pc
PvZ-041	Power Warning Label 110-120V VERSION	Adhesive Silk Screen Print		1	pc
PvZ-042	Front Playfield LED Acrylic Cover Strip	Clear Acrylic		1	Pc
PvZ-043	Zombie Light Acrylic Cover	Dull Polish Acrylic		6	Pc
PvZ-044	Header Downward Light Acrylic Cover	Clear Acrylic		1	Pc

PvZ-045	Playfield Cover Panel	Green ABS		1	Pc
PvZ-046	PVC Zombie Character	PVC		6	Pc
PvZ-047	Zombie Seat	Plastic		6	Pc
PvZ-048	Zombie Washer	Plastic		6	Pc
PvZ-049	Zombie Upper Shockproof Rubber	Black Rubber		6	Pc
PvZ-050	Coil Upper Holder	Plastic		6	Pc
PvZ-051	Coil Bottom Holder	Plastic		6	Pc
PvZ-052	Zombie Downward Shockproof Ring	Plastic		6	Pc

PvZ-053	Zombie Downward Shockproof Rubber	Black Rubber		6	Pc
PvZ-054	Pea Shooter Mallet			1	Pc
PvZ-055	Shockproof Rubber Underneath The Zombie Assemble	Black Rubber		2	Pc
PvZ-056	Ticket Dispenser Transformer Board			1	Pc
PvZ-057	Main Board			1	Pc
PvZ-058	Extension Board			1	Pc
PvZ-059	3 Digits LED Display			1	Pc
PvZ-060	4 Digits LED Display			1	Pc

PvZ-061	Header LED Light Strip (middle)	70CM		1	Pc
PvZ-062	Header LED Light Strip (side)	65CM		2	Pc
PvZ-063	Green LED Light Strip	70CM		3	Pc
PvZ-064	White LED Light Strip (Downward)	70CM		2	Pc
PvZ-065	Transformer	BK-300		1	Pc
PvZ-066	IR Sensor Board			6	Pc
PvZ-067	Power Switch			1	Pc
PvZ-068	Coin Mech	TW-130		1	Pc

PvZ-069	Ticket Dispenser			1	Pc
PvZ-070	Power Supply	PMC-12V100W1AA		1	Pc
PvZ-071	Fan 1 (For Cabinet Back Side)	12cm*12cm		1	Pc
PvZ-072	Coil			6	Pc
PvZ-073	Fan 2 (For Main Board / Zombie)	8cm*8cm		2	Pc
PvZ-074	Speaker	6"		2	Pc
PvZ-075	Potentiometer	100K		1	Pc
PvZ-076	Low Ticket Indicator Light			1	Pc

PvZ-077	Meter Button			4	Pc
PvZ-078	3A Fuse	3A		1	Pc
PvZ-079	10A Fuse	10A		1	Pc
PvZ-080	Capsule Indicator Light	Red Light		1	Pc
PvZ-081	Meter			3	Pc
PvZ-082	Support Foot	M16*70		4	Pc
PvZ-083	Castor	2"		4	Pc
PvZ-084	3157 Lock	3157		2	Pc

PvZ-085	3172 Lock	3172		3	Pc
PvZ-086	Mallet Rope	1M		1	Pc
PvZ-087	Fan Net 1 (For Cabinet Back Side)	12cm*12cm		3	Pc
PvZ-088	Fan Net 2 (For Main Board / Zombie)	8cm*8cm		2	Pc
PvZ-089	Sink Hexangular Screw	M4X22		16	Pc
PvZ-090	Washer	M4		16	Pc
PvZ-091	Capsule Hopper	From Sega		1	Pc
PvZ-092	Capsule Mech	From Sega		1	Pc