

1<sup>st</sup> PRINTING

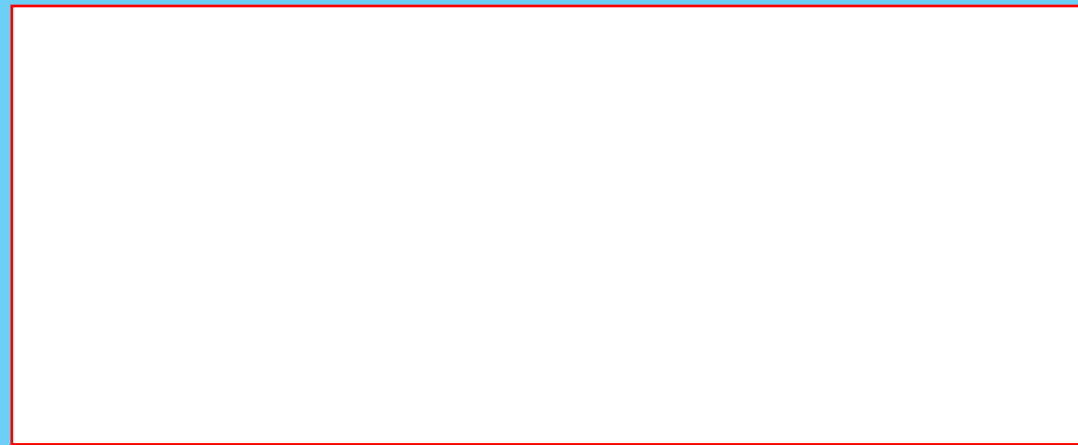

PIRATES OF MONSTER ISLAND

OWNER'S MANUAL

420-0018UK



OWNER'S MANUAL

# PIRATES OF MONSTER ISLAND



### IMPORTANT

- Before using this product, read this manual carefully to understand the contents herein stated.
- After reading this manual, be sure to keep it near the product or in a convenient place for easy reference when necessary.

## BEFORE USING THE PRODUCT, BE SURE TO READ THE FOLLOWING:

### To maintain safety:

To ensure the safe operation of this product, be sure to read the following before usage.

The following instructions are intended for the users, operators and the personnel in charge of the operation of the product. After carefully reading and sufficiently understanding the warning displays and cautions, handle the product appropriately. Be sure to keep this manual close to the product or in a convenient place for future reference.

Herein, explanations which require special attention are enclosed with dual lines. Depending on the potentially hazardous degrees, the terms of DANGER, WARNING, CAUTION, etc. are used. Be sure to understand the contents of the displays before reading the text.

 **DANGER** Indicates that mishandling the product by disregarding this pictograph will cause severe injury or death.

 **WARNING** Indicates that mishandling the product by disregarding this warning will cause a potentially hazardous situation which can result in death or serious injury.

 **CAUTION** Indicates that mishandling the product by disregarding this caution will cause a slight hazardous situation which can result in personal injury and/or material damage.

### For the safe usage of the product, the following pictographs are used:

 Indicates "HANDLE WITH CARE." In order to protect the human body and equipment, this display is attached to places where the Owner's Manual, Serviceman Manual and/or Service Manual should be referred to.

- **Perform work in accordance with the instructions herein stated.** Instructions for work are explained by paying attention to the aspect of accident prevention. Failing to perform work as per the instructions can cause accidents. In the case where only those who have technical expertise should perform the work to avoid hazardous situation, the instructions herein state that the site maintenance personnel should perform such work.
- **Be sure to turn off the power before working on the machine.** To prevent an electric shock, be sure to turn off the power before carrying out any work that requires direct contact with the interior of the product. If the work is to be performed in the power-on status, the Instruction Manual herein always states to that effect.
- **Be sure to ground the Earth Terminal.** (This is not required in the case where a power cord with earth is used.)
- **This product is equipped with the Earth Terminal.** When installing the product, connect the Earth Terminal to the "accurately grounded indoor earth terminal" by using an earth wire. Unless the product is grounded appropriately, the user can be subject to an electric shock. After performing repair, etc. for the control equipment, ensure that the Earth Wire is firmly connected to the control equipment.
- **Ensure that the Power Supply used is equipped with an Earth Leakage Breaker.** This product does not incorporate the Earth Leakage Breaker. Using a power supply which is not equipped with the Earth Leakage Breaker can cause a fire when earth leakage occurs.
- **Be sure to use fuses which meet the specified rating.** (Only for the machines which use fuses.) Using fuses exceeding the specified rating can cause a fire and an electric shock. (Only for the machines which use fuses.) Using fuses exceeding the specified rating can cause a fire and an electric shock.

- **Specification changes (removal of equipment, conversion and addition) not designated by SEGA are not allowed.** The parts of the product include warning labels for safety, covers for personal protection, etc. It is very hazardous to operate the product by removing parts and/or modifying the circuits. Should doors, lids and protective parts be damaged or lost, refrain from operating the product, and contact where the product was purchased from or the office herein stated. SEGA shall not be held responsible for any accidents, compensation for damage to a third party, resulting from the specifications not designated by SEGA.
- Ensure that the product meets the requirements of appropriate electrical specifications. Before installing the product, check for electrical specifications. SEGA products have a nameplate on which electrical specifications are described. Ensure that the product is compatible with the power supply voltage and frequency requirements of the location. Using any electrical specifications different from the designated specifications can cause a fire and an electric shock.
- Install and operate the product in places where appropriate lighting is available, allowing warning labels to be clearly read. To ensure safety for the customers, labels and printed instructions describing potentially hazardous situations are applied to places where accidents can be caused. Ensure that where the product is operated has sufficient lighting allowing the warnings to be read. If any label is peeled off, apply it again immediately. Please place an order with where the product was purchased from or the office herein stated.
- When handling the monitor, be very careful. (Applies only to products with monitors.) Some of the monitor parts are subject to high tension voltage. Even after turning off the power, some portions are still subject to high tension voltage sometimes. Monitor repair and replacement should be performed only by those technical personnel who have knowledge of electricity and technical expertise.
- Be sure to adjust the monitor properly. (Applies only to products with monitors.) Do not operate the product leaving on-screen flickering or blurring as it is. Using the product with the monitor not properly adjusted may cause dizziness or a headache to an operator, a player, or the customers.
- When transporting or reselling this product, be sure to attach this manual to the product.
- *In the case where commercially available monitors and printers are used in this product, only the contents relating to this product are explained herein. Some commercially available equipment has functions and reactions not stated in this manual. Read this manual together with the specific instruction manual of such equipment.*
- *Descriptions herein contained may be subject to improvement changes without notice.*
- *The contents described herein are fully prepared with due care. However, should any question arise or errors be found, please contact SEGA.*

## INSPECTIONS IMMEDIATELY AFTER TRANSPORTING THE PRODUCT TO THE LOCATION

Normally, at the time of shipment, SEGA products are in a status allowing for usage immediately after transporting to the location. Nevertheless, an irregular situation may occur during transportation. Before turning on the power, check the following points to ensure that the product has been transported in a satisfactory status.

- Are there any dented portions or defects (cuts, etc.) on the external surfaces of the cabinet?
- Are casters and adjusters damaged?
- Do the power supply voltage and frequency requirements meet with those of the location?
- Are all wiring connectors correctly and securely connected? Unless connected in the correct way, connector connections can not be made accurately. Do not insert connectors forcibly.
- Do power cables have cuts and dents?
- Are all accessories available?
- Can all doors and lids be opened with the accessory keys? Can doors and lids be firmly closed?

# INTRODUCTION

This manual is intended to provide detailed descriptions together with all necessary information covering the general operation of electronic assemblies, electro-mechanicals, servicing control, spare parts, etc. for the product, "PIRATES of MONSTER ISLAND"

This manual is intended for the owners, personnel managers in charge of operation of this product. Operate the product after carefully reading and sufficiently understanding the instructions.

In the unlikely event that the product does not function correctly, DO NOT allow anyone other than a technician to touch the internal system. Turn off the power to the machine, making sure to unplug the electrical cord from the outlet, and contact the office listed below or the point-of-purchase for this product.

Use of this product is unlikely to cause physical injuries or damage to property. However, points that require special attention are indicated by bold text, the word "IMPORTANT" and the symbol below.

## IMPORTANT

Indicates important information that, if ignored, may result in the mishandling of the product and cause faulty operation or damage to the product.

### Sega Amusements Europe Limited.

42 Barwell Business Park, Leatherhead Road, Chessington, Surrey, KT9 2NY. United Kingdom.

Telephone: +44 (0) 208 391 8090 Facsimile: +44 (0) 208 391 8099  
email: sales@segaarcade.com Web: <http://www.segaarcade.com>.

### Sega Total Solutions

42 Barwell Business Park, Leatherhead Road, Chessington, Surrey, KT9 2NY. United Kingdom.

Telephone: +44 (0) 208 391 8060 Facsimile: +44 (0) 208 391 8096  
email: sales@segaarcade.com Web: <http://www.segaarcade.com/spares>

### Play it! Amusements

252 Beinoris Drive, Wood Dale, IL. 60191, USA

USA Sales/Service +00(1) 224 265 4287

## SPECIFICATIONS

### CABINET

Machine Dimensions: 1,11m (43.7in.) [Width] x 1.70m (66.9in.) [Depth]  
Machine Height: 2.2m (86.6in.) (Installed)  
Machine Weight: 220kg Approx (Installed)

Power, maximum current: 2A (480w) @ 220~240Vac

## Definition of 'Site Maintenance Personnel or Other Qualified Individuals



**Procedures not described in this manual or marked as 'to be carried out by site maintenance personnel or other qualified professionals' should not be carried out by personnel without the necessary skill or technology. Work carried out by unqualified persons may cause serious accidents, including electrocution.**

Parts replacement, maintenance inspections and troubleshooting should be carried out by site maintenance personnel or other qualified professionals. This manual includes directions for potentially dangerous procedures which should only be carried out by professionals with the appropriate specialised knowledge.

The site maintenance personnel or other qualified professionals mentioned in this manual are defined as follows:

**Site maintenance personnel:**

Individuals with experience in maintaining amusement equipment, vending machines, etc., working under the supervision of the owner/operator of this product to maintain machines within amusement facilities or similar premises by carrying out everyday procedures such as assembly, maintenance inspections, and replacement of units/expendable parts.

**Activities to be carried out by site maintenance personnel:**

Amusement equipment/vending machine assembly, maintenance inspection and replacement of units/expendable parts.

**Other qualified professionals:**

Persons employed by amusement equipment manufacturers, or involved in design, production, testing or maintenance of amusement equipment. The individual should have either graduated from technical school or hold similar qualifications in electrical/electronics/mechanical engineering.

**Activities to be carried out by other qualified professionals:**

Amusement equipment/vending machine assembly, repair/adjustment of electrical/electronic/mechanical parts.

### Waste of Electrical and Electronic Equipment (WEEE) Statement.

The WEEE (Waste of Electrical and Electronic Equipment) directive places an obligation on all EU based manufacturers and importers of Electrical and Electronic Equipment to take back products at the end of their useful life. Sega Amusements Europe Ltd accepts its responsibility to finance the cost of treatment and recovery of redundant WEEE in the United Kingdom in accordance with the specified WEEE recycling requirements.

The symbol shown below will be on all products manufactured from 13th August 2005, which indicates this product must NOT be disposed of with other normal waste. Instead, it is the user's responsibility to dispose of their waste equipment by arranging to return it to a designated UK collection point for the correct recycling of waste electrical and electronic equipment.

For more information about where you can send your waste equipment for recycling contact your local authority of-fice.

For non-UK users contact your local authority office for information on the recycling of Waste Electrical and Elec-tronic Equipment.

### Battery Recycling Statement.

The EC Directive on Batteries and Accumulators (2006/66/EC) aims to minimise the impact of batteries on the en-vironment and encourage the recovery of the materials they contain. To achieve increased collection and recycling of waste batteries, the Directive places 'producer responsibility' obligations on manufacturers and importers of portable, industrial and automotive batteries.

The symbol shown below will be on all equipment fitted with batteries from 26th September 2008 and indicates they must NOT be disposed of with other normal waste. Instead, it is the user's responsibility to dispose of used batteries by arranging to return them to a designated collection point for the correct recycling.

For more information about where you can send your waste batteries for recycling contact your local authority of-fice.



REGISTERED IN ENGLAND REGISTERED NO. 1711515

REGISTERED OFFICE: BLOCK C 42 BARWELL BUSINESS PARK, CHESSINGTON, SURREY KT9 2NY

Notes:

**INTRODUCTION**

Intentionally left blank

# TABLE OF CONTENTS

|  |            |
|--|------------|
| <b>INTRODUCTION</b>                                | <b>iii</b> |
| <b>1 HANDLING PRECAUTIONS</b>                      | <b>1</b>   |
| <b>2 PRECAUTIONS REGARDING INSTALLATION</b>        | <b>4</b>   |
| <b>3 PRECAUTIONS REGARDING OPERATION</b>           | <b>7</b>   |
| <b>4 PART DESCRIPTIONS</b>                         | <b>10</b>  |
| <b>5 ACCESSORIES</b>                               | <b>11</b>  |
| <b>6 ASSEMBLY AND INSTALLATION</b>                 | <b>12</b>  |
| 6-1 INSTALLING THE CABINET                         | 13         |
| 6-2 INSTALLING THE TICKETS                         | 16         |
| 6-3 FIXATION TO SITE                               | 18         |
| 6-4 POWER SUPPLY AND OTHER CONNECTIONS             | 20         |
| 6-5 TURNING ON THE POWER                           | 21         |
| <b>PRECAUTIONS WHEN MOVING THE MACHINE</b>         | <b>23</b>  |
| 7-1 PRECAUTIONS WHEN MOVING FROM SITE              | 24         |
| <b>8 GAME DESCRIPTION</b>                          | <b>25</b>  |
| 8-1 GAME OUTLINE                                   | 25         |
| <b>9 EXPLANATION OF TEST AND DATA DISPLAY</b>      | <b>27</b>  |
| 9-1 SWITCH UNIT AND COIN METER.                    | 28         |
| 9-2 TEST MODE                                      | 29         |
| 9-3 I/O CHECK                                      | 30         |
| 9-4 GUN CHECK                                      | 32         |
| 9-5 SCREEN CHECK                                   | 33         |
| 9-6 GAME OPTIONS                                   | 34         |
| 9-7 SOUND OPTIONS                                  | 35         |
| 9-8 COIN OPTIONS                                   | 36         |
| 9-9 TICKET OPTIONS                                 | 37         |
| 9-10BOOKKEEPING                                    | 38         |
| 9-11ALL FACTORY SETTINGS                           | 40         |
| <b>10 CONTROLLER UNIT(S), SWITCHES AND BUTTONS</b> | <b>41</b>  |
| 10-1 REMOVING THE CONTROLLER                       | 42         |
| 10-2 ADJUSTING/REPLACING THE VOLUME POT            | 44         |
| 10-3 GREASING                                      | 47         |
| <b>11 LCD DISPLAY (VGA)</b>                        | <b>48</b>  |
| 11-1 SAFETY PRECAUTIONS WHEN HANDLING THE MONITOR  | 48         |



|           |   |           |
|-----------|---|-----------|
| <b>12</b> | <b>COIN HANDLING</b>                                  | <b>54</b> |
|           | 12-1 CLEANING THE COIN SELECTOR                       | 54        |
|           | 12-2 FAULT FINDING                                    | 57        |
|           | 12-3 ADJUSTING THE PRICE OF PLAY (EXCEL)              | 58        |
|           | 12-4 ADJUSTING THE PRICE OF PLAY (VTS)                | 59        |
| <b>13</b> | <b>LAMPS AND LIGHTING</b>                             | <b>63</b> |
|           | 13-1 COIN DOOR LAMP                                   | 63        |
|           | 13-2 FLUORESCENT TUBES - BILLBOARD                    | 64        |
| <b>14</b> | <b>PERIODIC INSPECTION</b>                            | <b>68</b> |
| <b>15</b> | <b>TROUBLESHOOTING</b>                                | <b>70</b> |
|           | 15-1 TROUBLESHOOTING (WHEN NO ERROR MESSAGE IS SHOWN) | 70        |
| <b>16</b> | <b>GAME BOARD</b>                                     | <b>72</b> |
| <b>17</b> | <b>RF 8 KEY LED RGB CONTROLLER</b>                    | <b>75</b> |
| <b>18</b> | <b>DESIGN-RELATED PARTS</b>                           | <b>76</b> |
| <b>19</b> | <b>PARTS LIST</b>                                     | <b>77</b> |
| <b>20</b> | <b>WIRE COLOUR CODE TABLE</b>                         | <b>81</b> |
| <b>21</b> | <b>SCHEMATIC DIAGRAMS</b>                             | <b>82</b> |

# 1 HANDLING PRECAUTIONS

When installing or inspecting the machine, be very careful of the following points and pay attention to ensure that the player can enjoy the game safely.

Noncompliance with the following points or inappropriate handling running counter to the cautionary matters herein stated can cause personal injury or damage to the machine.

## WARNING

Before performing work, be sure to turn the power off. Performing the work without turning the power off can cause an electric shock or short circuit. In cases where work should be performed in the status of power on, this manual always states to that effect.

To avoid an electric shock or short circuit, do not plug in or unplug quickly.

To avoid an electric shock, do not plug in or unplug with a wet hand.

**Do not expose power cords or earth wires on the surface, (floor, passage, etc.)** If exposed, the power cords and earth wires are susceptible to damage. Damaged cords and wires can cause an electric shock or short circuit.

To avoid causing a fire or an electric shock, do not put things on or damage the power cords.

When or after installing the product, do not unnecessarily pull the power cord. **If damaged, the power cord can cause a fire or an electric shock.**

In case the power cord is damaged, ask for a replacement through where the product was purchased from or the office herein stated. **Using the cord as is damaged can cause fire, an electric shock or leakage.**

Be sure to perform grounding appropriately. Inappropriate grounding can cause an electric shock.

**Be sure to use fuses meeting the specified rating. Using fuses exceeding the specified rating can cause a fire or an electric shock.**

Be sure that connections such as IC BD are made properly. Insufficient insertion can cause an electric shock.

**Specification changes, removal of equipment, conversion and/or addition, not designated by SEGA are not permitted.**

Failure to observe this may cause a fire or an electric shock. **Non-compliance with this instruction can have a bad influence upon physical conditions of the players or the onlookers, or result in injury during play.**

SEGA shall not be held responsible for damage, compensation for damage to a third party, caused by specification changes not designated by SEGA.

Do not perform any work or change parts not listed in this manual. Doing so may lead to an accident.

If you need to perform any work not listed in this manual, request work from the office indicated in this manual or the point of purchase, or inquires for details.

Be sure to perform periodic maintenance inspections herein stated.

## **STOP** IMPORTANT

For the IC board circuit inspections, only the use of a logic tester is recommended. Using a Multi Tester or General Purpose Tester may result in damage to IC Circuits.

Static electricity from your body may damage some electronics devices on the IC board. Before handling the IC board, touch a grounded metallic surface so that the static electricity can be discharged.

This video gaming cabinet utilises a motorised steering feedback system. Do not attempt to service this part or any other part in close proximity to the steering mechanism whilst power is applied.

Some parts are not designed and manufactured specifically for this game machine. The manufacturers may discontinue, or change the specifications of such general-purpose parts. If this is the case, SEGA cannot repair or replace a failed game machine whether or not a warranty period has expired.

### CONCERNING THE STICKER DISPLAY

This SEGA product has stickers attached describing the product manufacture No. (Serial No.) and Electrical Specifications. It also has a Sticker describing where to contact for repair and for purchasing parts.

When inquiring about or asking for repairs, mention the Serial No. and Name of Machine indicated on the Sticker. The Serial Number indicates the product register. Identical machines could have different parts depending on the date of production. Also, improvements and modifications might have been made after the publication of this manual. In order to ensure you order the correct parts, mention the Serial No. when contacting the applicable places.

### CONCERNING WARNING DISPLAYS

This SEGA product has warning displays on stickers, labels and/or printed instructions adhered/attached to or incorporated in the places where a potentially hazardous situation could arise. The warning displays are intended for accident prevention for customers and for avoiding hazardous situations relating to maintenance and servicing work. Some portions of the cabinet contain high voltage and may cause accidents if touched. When performing maintenance, be very careful of the warning displays. It is especially important that any complex repair and replacement work not mentioned herein should be performed by those technical personnel who have knowledge of electricity and technical expertise.

In order to prevent accidents, caution any customer ignoring the warnings to cease and desist immediately.

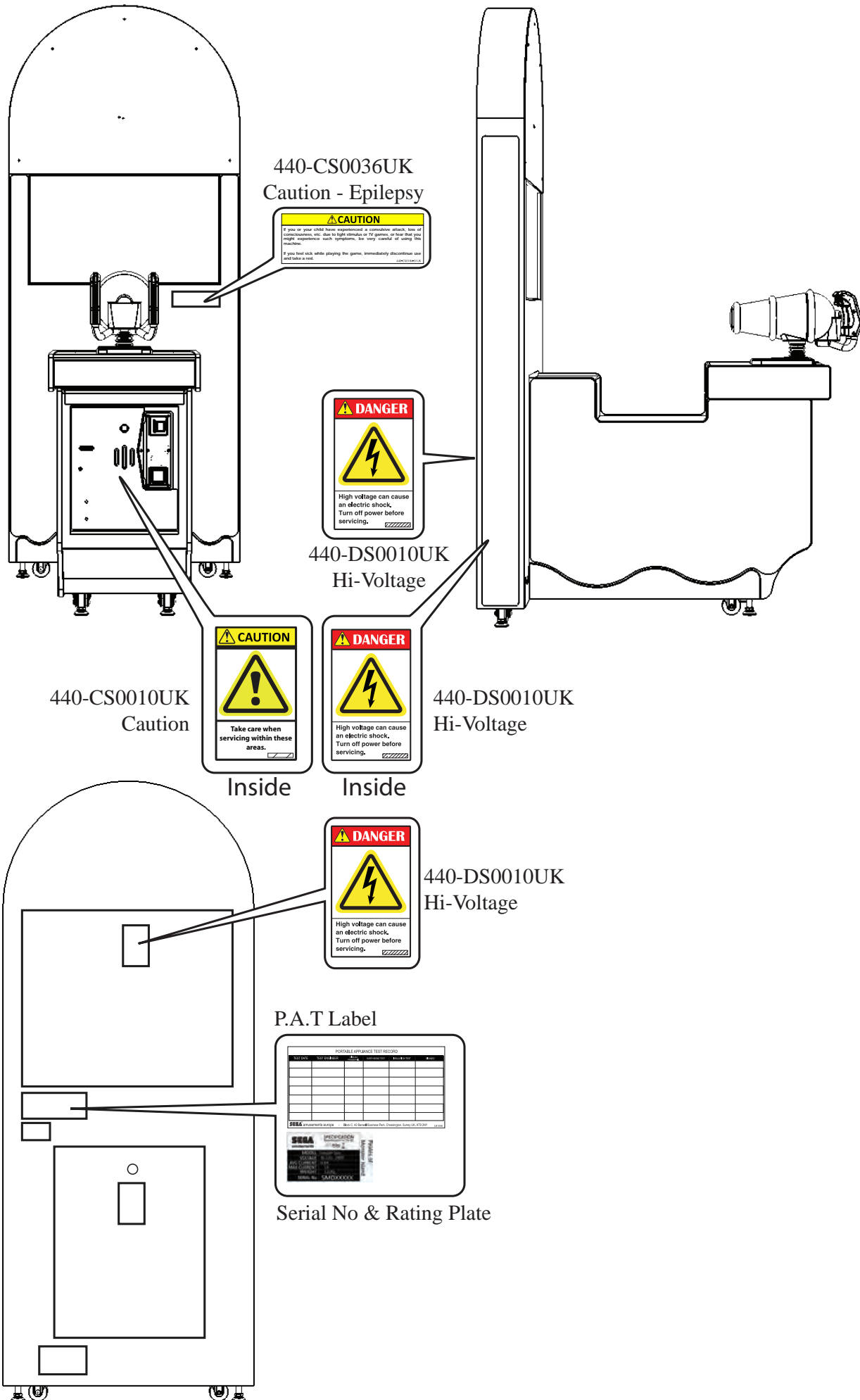

**1** HANDLING PRECAUTIONS

## 2 PRECAUTIONS REGARDING INSTALLATION

### WARNING

This product is an indoor game machine. Do not install it outside. Even indoors, avoid installing in places mentioned below so as not to cause a fire, electric shock, injury and/or malfunction.

Places subject to rain or water leakage, or places subject to high humidity in the proximity of an indoor swimming pool and/or shower, etc.

Places subject to direct sunlight, or places subject to high temperatures in the proximity of heating units, etc.

Places filled with inflammable gas or vicinity of highly inflammable/volatile chemicals or hazardous matter.

Dusty places.

Sloped surfaces.

Places subject to any type of violent impact.

**Vicinity of anti-disaster facilities such as fire exits and fire extinguishers.**

Areas where the temperature exceeds the applicable temperature (ambient temperature) range of 5 to 30 degrees centigrade.

### LIMITATIONS OF USAGE

### WARNING

Be sure to check the Electrical Specifications. Ensure that this product is compatible with the location's power supply, voltage, and frequency requirements. A plate describing Electrical Specifications is attached to the product. **Non-compliance with the Electrical Specifications can cause a fire and electric shock.**

This product requires a breaker and earth mechanism as part of the location facilities. **Using the product without these can cause a fire and electric shock.**

Ensure that the indoor wiring for the power supply is rated at 15 A or higher (AC single phase 100 V ~ 120 V area), and 7 A or higher (AC 220 V ~ 240 V area). **Non-compliance with the Electrical Specifications can cause a fire and electric shock.**

Be sure to use an independent power supply equipped with an earth leakage breaker. Using a power supply without an earth leakage breaker can cause an **outbreak of fire if a power surge occurs.**

Putting many loads on one electrical outlet can cause generation of heat and a **fire resulting from overload.**

When using an extension cord, ensure that the cord is rated at 15 A or higher (AC 100 V ~ 120 V area) and 7 A or higher (AC 220 V ~ 240 V area). Using a cord rated **lower than the specified rating can cause a fire and electric shock.**

**STOP IMPORTANT**

Securing a safe area for operation as described in this manual will ensure safe operation for players and observers.

SEGA shall not be held responsible for damage or compensation for damage to a third party, resulting from the failure to observe this instruction.

OPERATION AREA (SINGLE CABINET)

**WARNING**

For the operation of this machine, please secure a minimum area of 2.06m (D) and 1.35m (W)

Be sure to provide sufficient space specified in this manual. Do not allow objects to block the ventilation ports. It can cause generation of heat and a fire.

Sufficient space either side of the playing area must be allowed for the player to enter or exit the game safely.

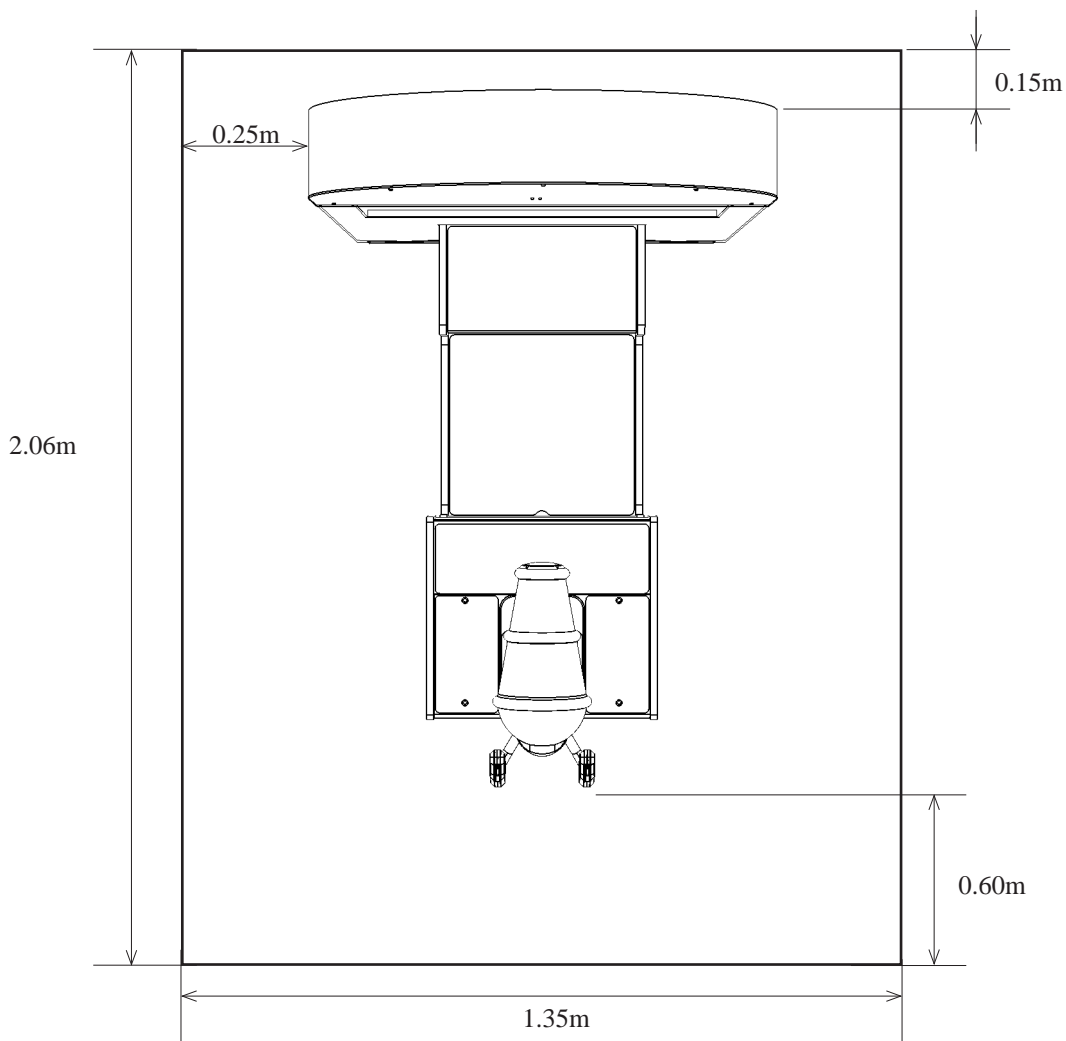

**STOP** **IMPORTANT**

To install this product, the entrance must be at least 0.88m in width and 2.14 m in height.

Do not attempt to push/pull the machines whilst holding onto the Controller or Assy Billboard. This may result in part damage and or personal injury.

**2** PRECAUTIONS REGARDING INSTALLATION LOCATION

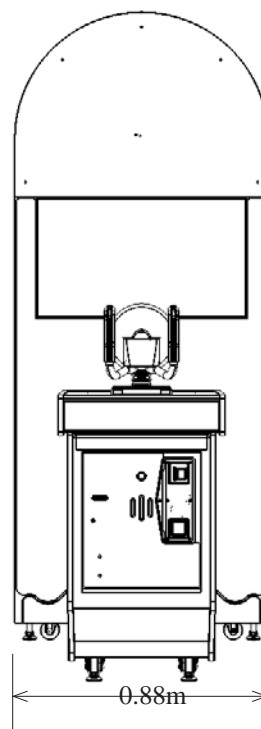
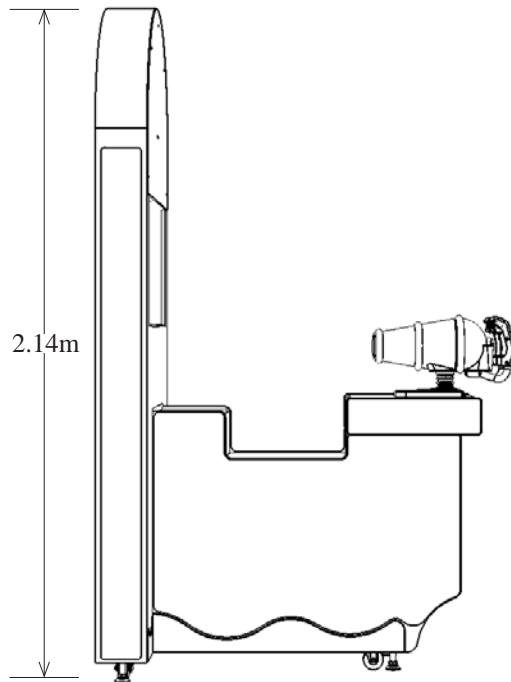

### 3 PRECAUTIONS REGARDING OPERATION

To avoid injury and trouble, be sure to pay attention to the behavior of visitors and players.

#### WARNING

In order to avoid accidents, check the following before starting the operation:

- To ensure maximum safety for the players and the customers, ensure that where the product is operated has sufficient lighting to allow any warnings to be read. Operation under insufficient lighting can cause bodily contact with each other, hitting accident, and/or trouble between customers.
- Be sure to perform appropriate adjustment of the display (LCD, Plasma, CRT or Projector). For operation of this machine, do not leave monitor's flickering or deviation as is. Failure to observe this can have a bad influence upon the players' or the customers' physical conditions.
- It is suggested to ensure a space allowing the players who feel sick while playing the game to take a rest.
- Check if all of the adjusters are in contact with the surface. If they are not, the Cabinet can move and cause an accident.
- Do not put any heavy item on this product. Items, if placed on this product may fall and cause injury to the player / observer.
- Do not climb on the product. Climbing on the product can cause falling down accidents. To check the top portion of the product, use a step ladder.

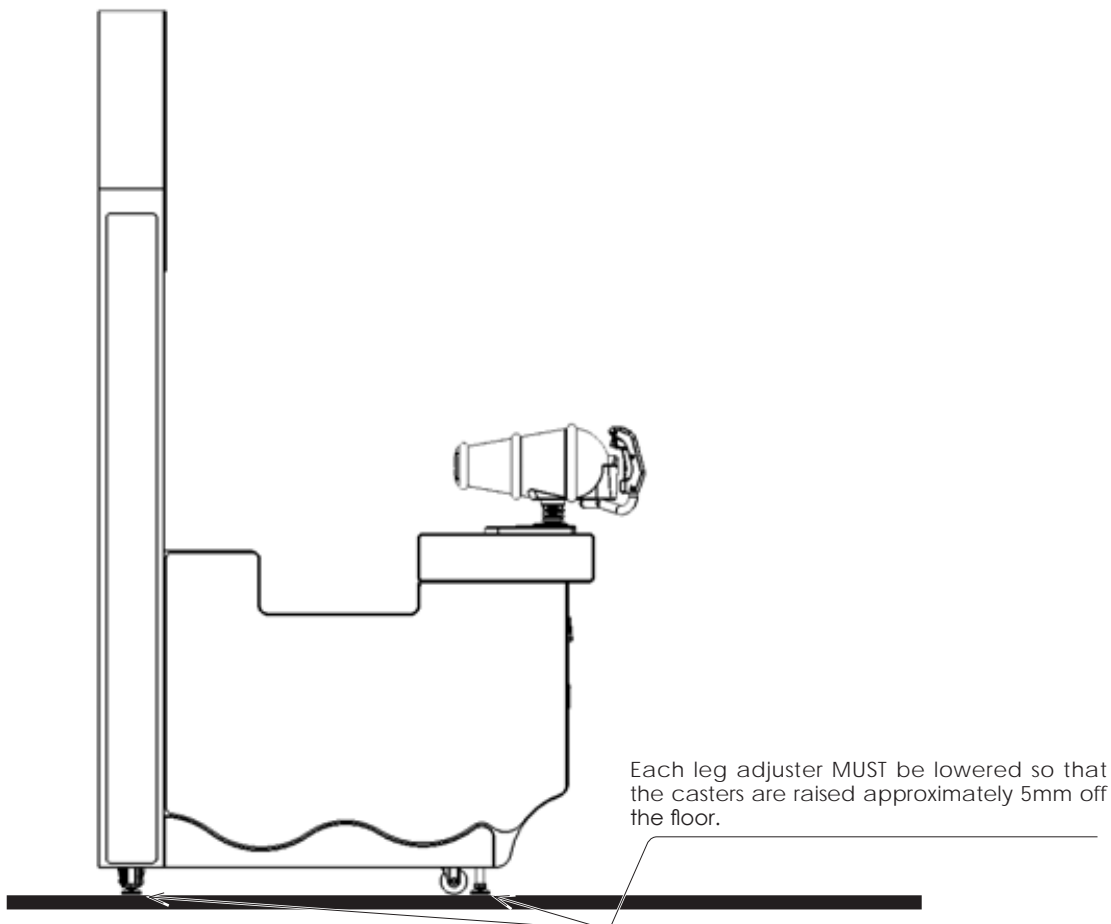



### **⚠ WARNING**

- To avoid electric shock, ensure that all covers and panels are undamaged and fitted. Do not operate with covers removed.
- To avoid electric shock, short circuit and/or parts damage, do not put the following items on or in the periphery of the product.
- Flower vases, flowerpots, cups, water tanks, cosmetics, and receptacles/containers/vessels containing chemicals and water.

### **⚠ CAUTION**

- To avoid injury, be sure to provide sufficient space by considering the potentially crowded situation at the installation location. Insufficient installation space can cause making bodily contact with each other, hitting accidents, and/or trouble between customers.
- Everyday when cleaning the Controller, inspect the controller and make sure that there are no cracks in the surface, and that the fastening screws are not loose. If the game is played with cracks or loose screws, it can cause injuries to the player.

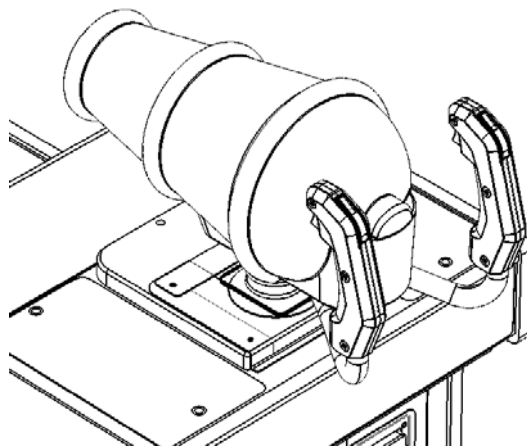

- It is recommended that wet towels (paper towels) be provided.

## DURING OPERATION (PAYING ATTENTION TO CUSTOMERS)

To avoid injury and trouble, be sure to constantly give careful attention to the behavior and manner of the visitors and players.

### **WARNING**

- For safety reasons, do not allow any of the following people to play the game.
- Those who have high blood pressure or a heart problem.
- Those who have experienced muscle convulsion or loss of consciousness when playing video games, etc.
- Those who have neck or spinal cord problems.
- Those who are intoxicated or under the influence of drugs.
- Pregnant women.
- Those who are not in good health.
- Those who do not follow the attendant's instructions.
- Those who cannot grasp the Control Unit securely because of immobility in fingers, hands or arms.
- Persons who disregard the product's warning displays.
- This product is intended for a single player only. Having two or more persons simultaneously playing this product can result to injury to the player and possible damage to the product.
- Even players who have never been adversely affected by light stimulus might experience dizziness or headache depending on their physical condition when playing the game.
- Small children are especially likely to experience these symptoms. Caution guardians of small children to keep watch on their children during play.
- Instruct those who feel sick during play to have a medical examination.
- To avoid injury from falls and electric shocks due to spilled drinks, instruct the player not to place heavy items or drinks on the product.
- To avoid electric shocks and short circuits, do not allow customers to put hands and fingers or extraneous matter in the openings of the product or small openings in or around the doors.
- To avoid falls and resulting injury, immediately stop the customer from leaning against or climbing on the product, etc.
- To avoid electric shock and short circuit, do not allow customers to unplug the power plug without a justifiable reason.
- Instruct the guardians of small children to keep an eye on their children.
- Children cannot sense danger. Allowing small children to get near a player who is playing the game could result in the children being bumped, struck or knocked down.

**3**

**PRECAUTIONS REGARDING PRODUCT OPERATION**

## 4 PART DESCRIPTIONS

### 4 PART DESCRIPTIONS

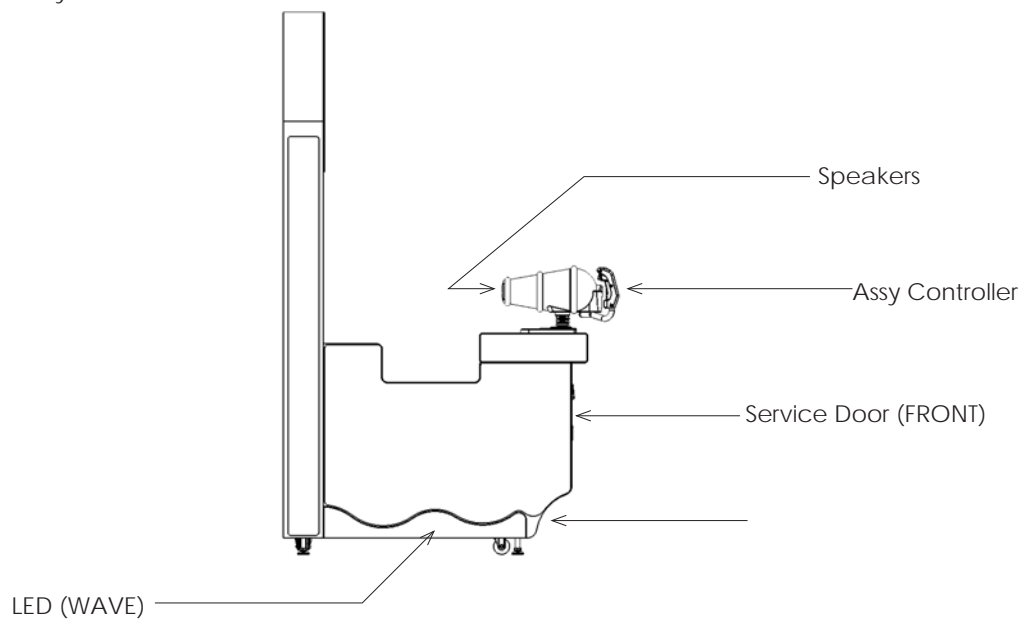
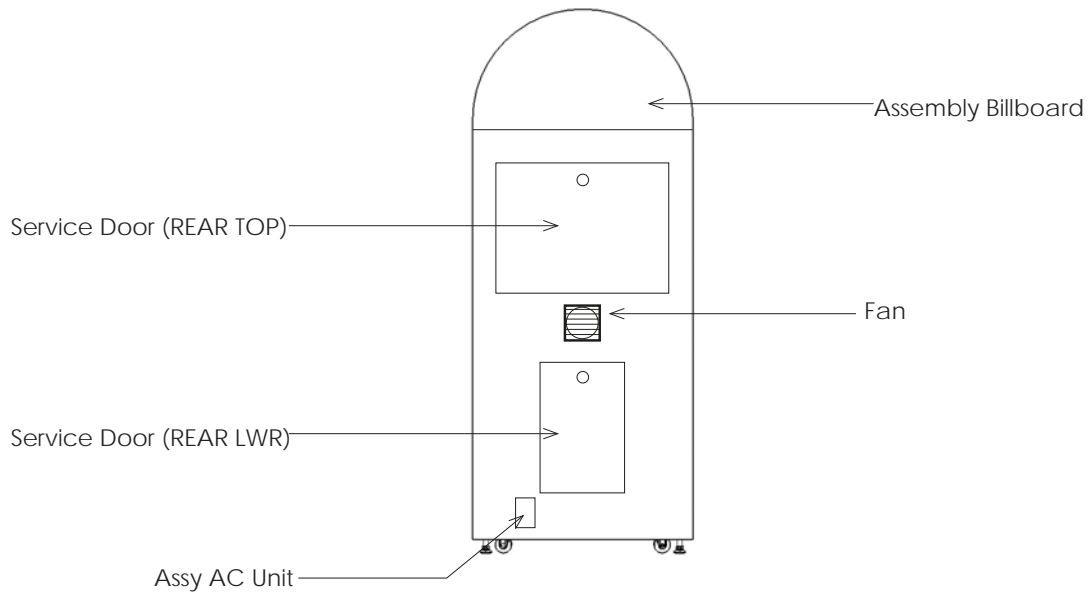
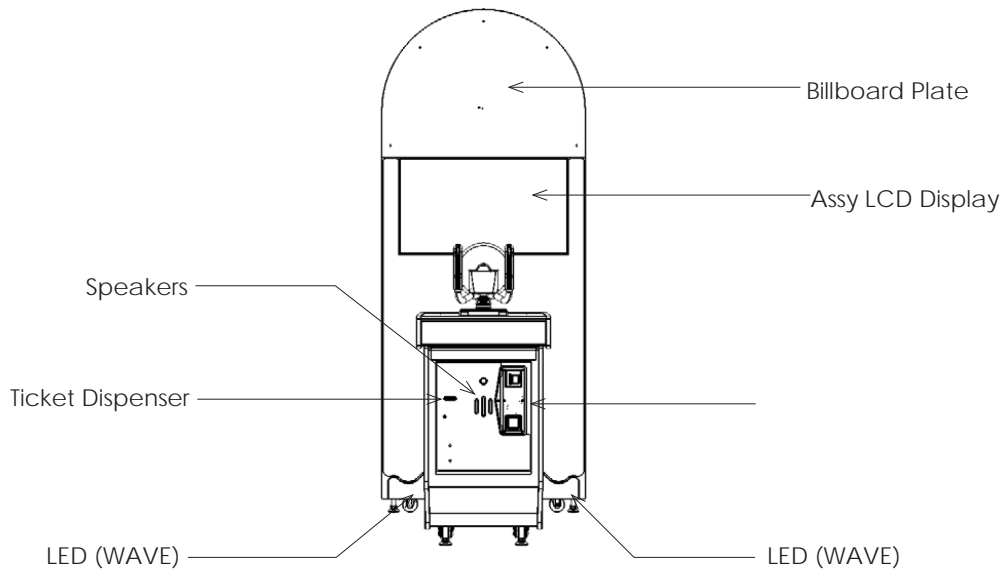

# 5 ACCESSORIES

Confirm that the accessories listed in the table below are present when setting up the product. Accessories marked “Spare” in the note column are consumable items but included as spares.

440-CS0186UK  
Sticker C Epilepsy Multi (1)



DESCRIPTION: OWNER'S MANUAL  
Part No. (Qty.): 420-00XXUK(1)

Parts not labeled with part numbers are as yet unregistered or cannot be registered. Be sure to handle all parts with care, as some parts are not available for purchase separately.

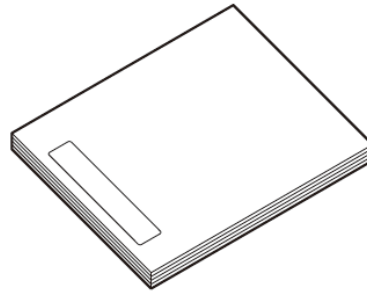

KEY  
(2)

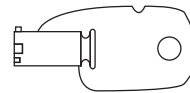

For the cashbox door  
(Located inside the coin chute door at time of shipment)

KEY MASTER

220-5575-01UK (4)

For operating/closing the doors

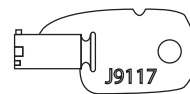

POWER CORD

LM1227 (1) <UK>

LM1226 (1) <EU>

or

LM1226 (1) <US>

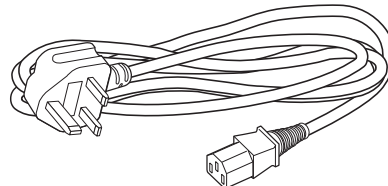

For installation. See chapter 6.

## **6 ASSEMBLY AND INSTALLATION**

### **WARNING**

- Perform assembly work by following the procedure herein stated. Failure to comply with the instructions can cause electric shock.
- Perform assembly as per this manual. Since this is a complex machine, incorrect assembling can cause an electric shock, machine damage and/or improper functioning as per specified performance.
- When assembling, more than one person is required. Depending on the assembly work, there are some cases in which working by one person alone can cause personal injury or parts damage.
- Ensure that connectors are properly connected. Improper connections can cause electric shock.
- Be careful not to damage the wires. Damaged wires may cause electric shock or short circuit or present a risk of fire.
- Do not unnecessarily push the display screen.
- This work should be carried out by site maintenance personnel or other qualified professionals. Work performed by non-technical personnel can cause a severe accident such as electric shock. Failing to comply with this instruction can cause a severe accident such as electric shock to the player during operation. If no one with proper technological expertise is available, request service from the office indicated in this document or the point of purchase so as to ensure safety.
- Provide sufficient space so that assembling can be performed. Performing work in places with narrow space or low ceiling may cause an accident and assembly work to be difficult.
- To perform work safely and avoid serious accident such as the cabinet falling down, do not perform work in places where step-like grade differences, a ditch, or slope exist.
- This product does not use any connectors other than those connected to and used by the game board when it leaves the factory. Do not needlessly connect wires to unused connectors. This could lead to overheating, generation of smoke and burn related injuries.

### **CAUTION**

- Handle molded parts with care. Excessive weight or pressure may cause them to break and the broken pieces may cause injury.
- To perform the operation safely and accurately you must use a safe, steady footstool or stepladder. Working without this may lead to a fall and possible injury.

## 6-1 INSTALLING THE CABINET

### CAUTION

- Billboard weighs approximately 19 kg. Have at least 2 people during this operation. Working alone could result in personal injuries, etc.
- To perform work safely and securely, be sure to prepare a step which is in a safe and stable condition. Performing work without using a step may lead to injury of damage to components.

Tools required for installation

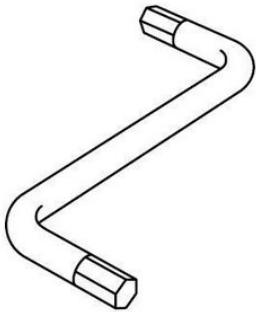

Allen Key (M5)  
- Attaching Billboard Panel to Assy Billboard.  
(Not Supplied)

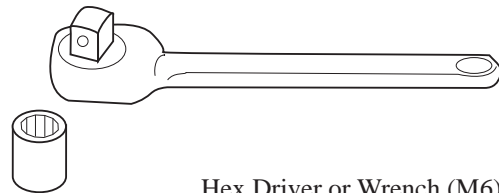

Hex Driver or Wrench (M6)  
- Attaching Assy Billboard.

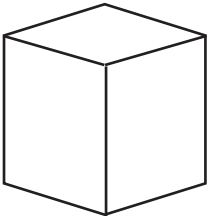

Step or Ladders  
- Aid in fixing Billboard and Billboard Panel.

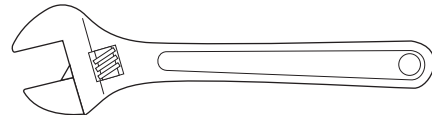

Adjustable Wrench  
- Secure cabinet into position.

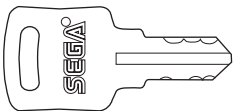

KEY  
- Gain access to Coin Tower

## 6-1-1 INSTALLING THE ASSY BILLBOARD

- 1 Locate the 2 Billboard brackets and make sure that they have not sustained any damage during transportation. Loosen the 4 fixings so that the brackets are not tight against the cabinet

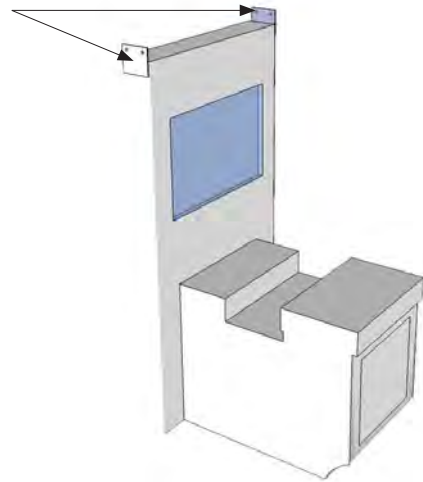

- 2 Unpack the Billboard and remove the 4x M4 machine screws located at the Billboard sides.

M4 Machine Screws  
(2 each side)

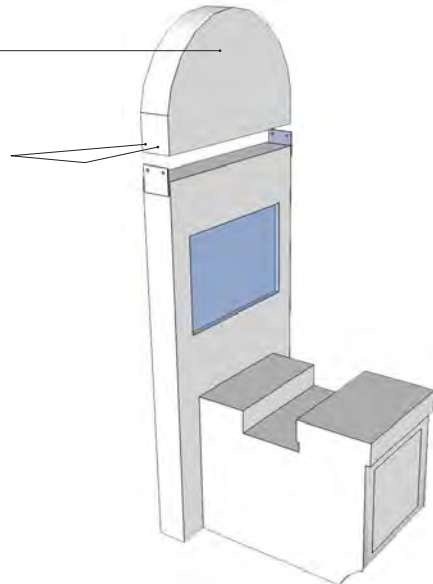

- 3 Slot the Billboard into place and fix using the 4x M4 machine screws removed from the Billboard in step 2. Tighten all 8 fixings.

Tighten all 8 fixings

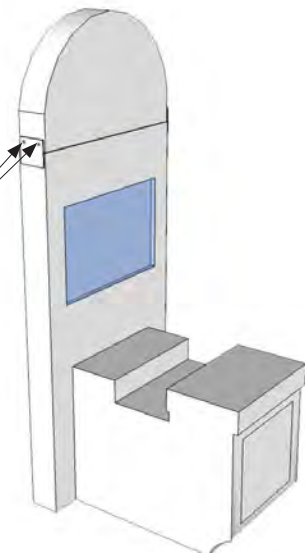

- 4** Unpack the Billboard Plate taking care not to damage the Lamp Holder which secures the lamp for the Pirates Eye.

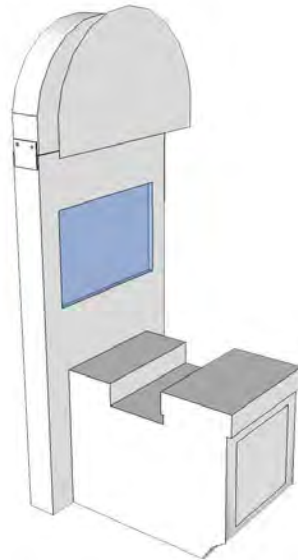

- 5** Locate and remove the 6 sets of fixings from the Plate fixing points within the Billboard. Next offer the Billboard Plate up to the Billboard and connect the Lamp in to the trailing harness within the Billboard. Secure the Billboard Plate in place. - Do not overtighten as this may damage the Billboard Plate.

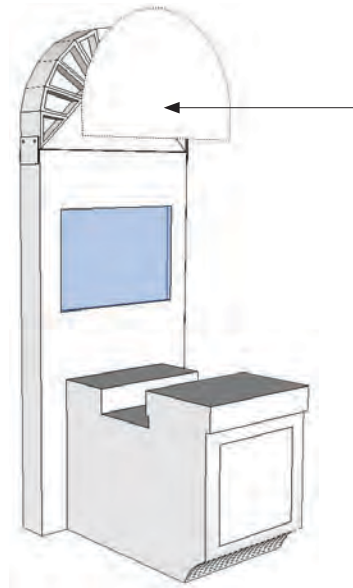



## 6-2 INSTALLING THE TICKETS

This game has a functional Ticket Unit installed. Please follow the instructions below on how to install tickets into the Ticket Unit.

- 1 Open the front door to allow access to the ticket unit.

Unlock & Open Front Door



- 2 Place the Tickets into the TICKET HOLDER.

Ticket Holder

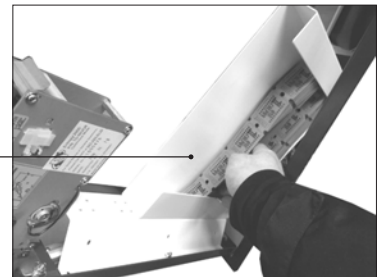

- 3 Feed the Tickets into the TICKET MECH.

Unclip and remove the Ticket retainier

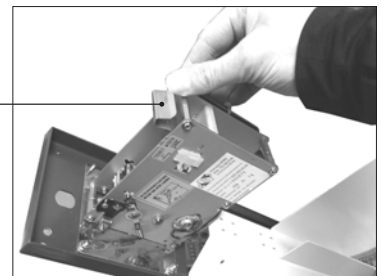

Feed the tickets into the mech, making sure that the ticket passes through the sensor.

Sensor

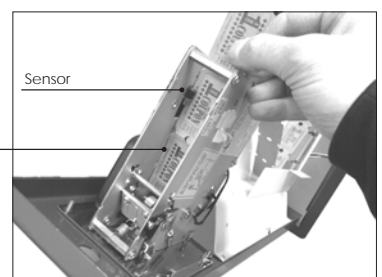

**4** Press the TEST button on the side of the VEND MECH PCB to check that the Tickets run smoothly through the unit.

Once the tickets have been fully inserted into the mech, replace the ticket retainer to secure tickets into position.

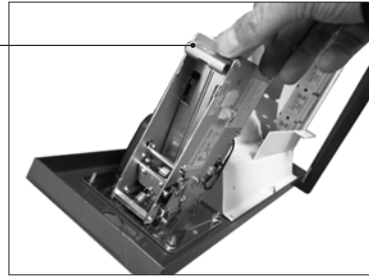

Press the TEST button on the PCB to draw tickets through the mech and out of the door.

Tear off any excess tickets

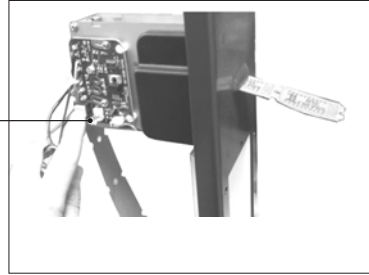

## 6-3 FIXATION TO SITE

### ⚠ WARNING

- Make sure that all the adjusters contact the floor. Otherwise the cabinet could move, causing an accident.
- Provide a ventilation space at least 15cm wide behind the cabinet. There are ventilation holes on the back of the cabinet. Do not block the ventilation holes. Doing so could trap heat inside resulting in fire. It could also result in equipment damage or cause parts to become exhausted prematurely.

The product is equipped with 4 casters and 4 adjusters.

When installation position / site has been determined, have the adjusters come in direct contact with the floor. Establish a gap of about 5 mm between the floor and the casters and adjust the unit so that it will remain level.

1 Move the product to the installation site.

2 Bring the adjusters into direct contact with the floor. Use a wrench to align the height of the adjusters until the cabinet is perfectly level.

3 After setting, turn adjuster nuts upwards to tighten them and secure adjuster heights.

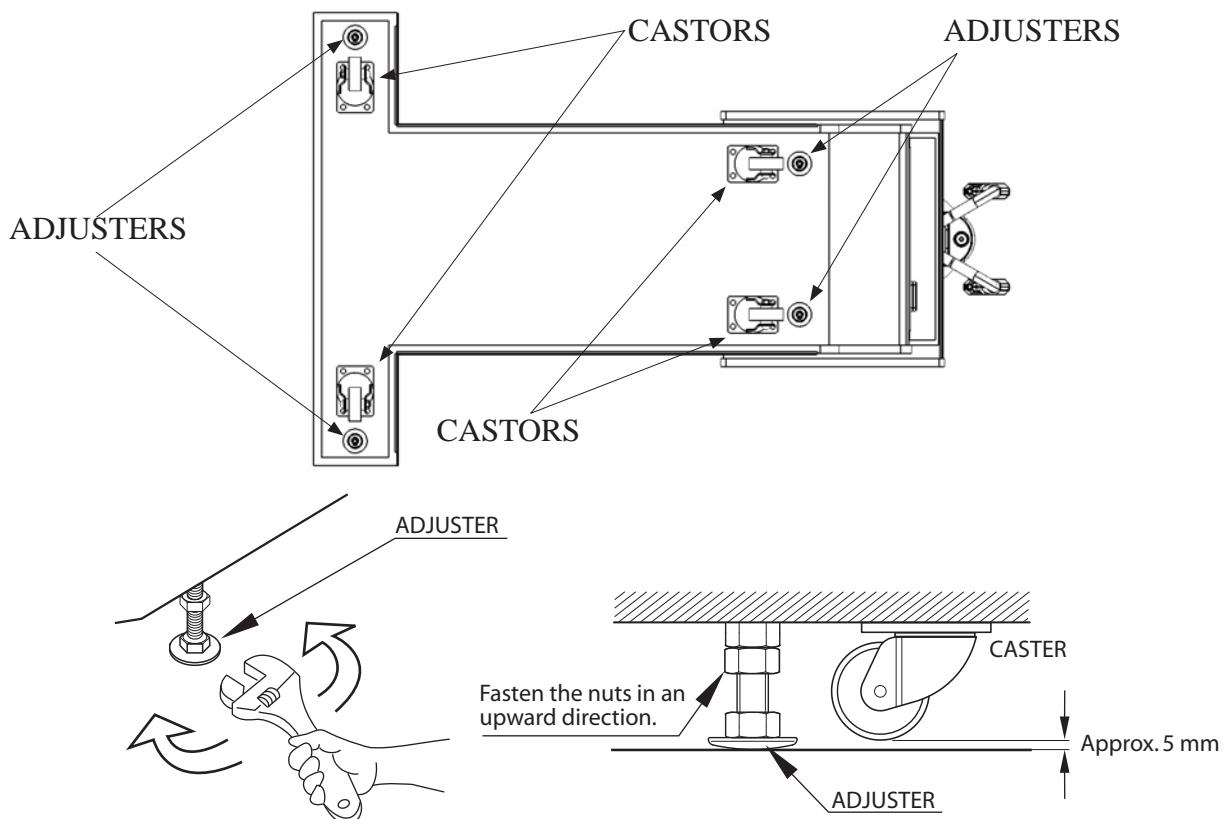

**⚠ WARNING**

- Provide a ventilation space at least 20cm wide behind the cabinet. There are ventilation holes on the back of the cabinet. Do not block the ventilation holes. Doing so could trap heat inside resulting in fire. It could also result in equipment damage or cause parts to become exhausted prematurely.

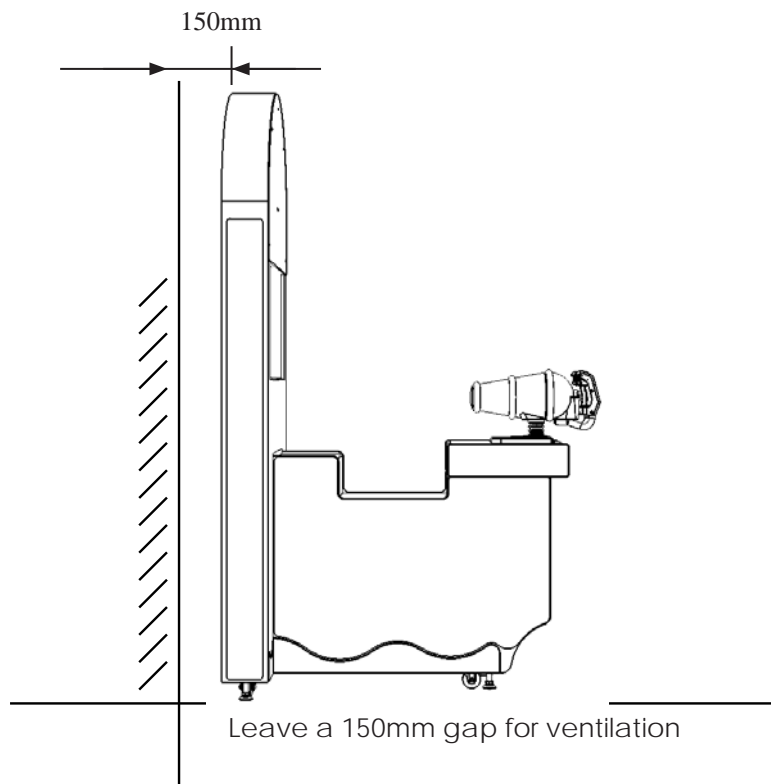

## 6-4 POWER SUPPLY AND OTHER CONNECTIONS

### WARNING

- Use the power supply equipped with an earth leakage breaker. Use of power supply without such a breaker could result in fire if there is a current leakage.
- Have available a securely grounded indoor ground terminal. Without proper grounding, customers could be electrocuted and product operations might not always be stable.
- Do not expose the power cord or ground wire. If these are exposed, customers could stumble over them, for instance, and easily damage them. Additionally, if these lines are damaged, there could be a risk of electrical shock or short circuit. Set these lines at locations where they will not interfere with customer traffic, or attach covers to them.
- After laying out the power cord on the floor, be sure to always protect it. If the power cord is left exposed, it can easily be damaged, resulting in electrical shock.

**1** Confirm that the main switch is at OFF.

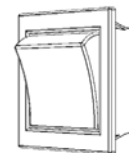
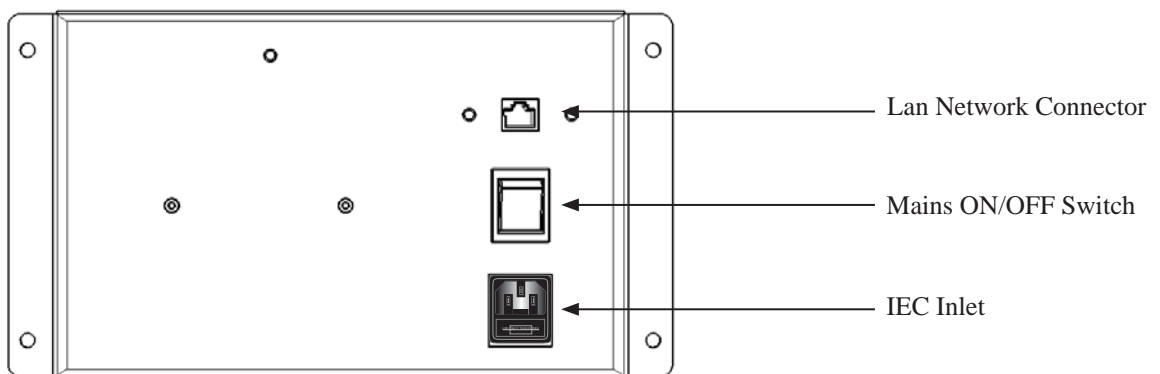

Mains Switch shown in OFF position

- 2 Fully insert the power cord connector on the side opposite the power plug into the AC unit IEC inlet. Insert the power cord plug into the outlet.

- 3 The power code is laid out indoors. Protect the power cord by attaching wire cover to it.

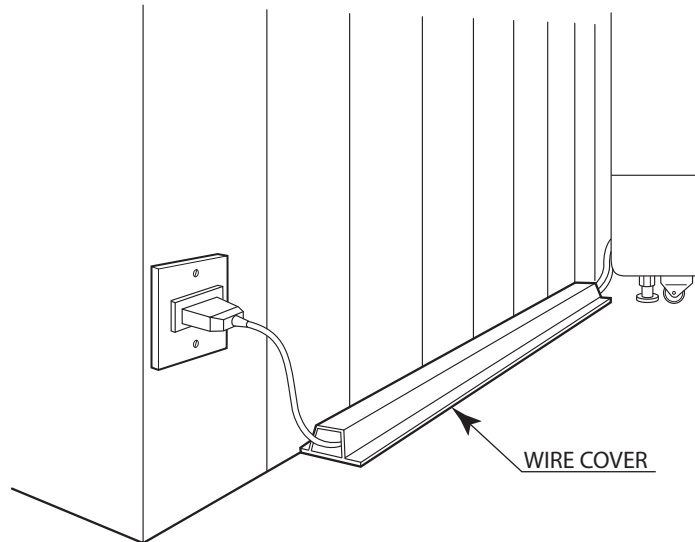

## 6-5 TURNING ON THE POWER

Set the main switch of the AC unit to ON and engage the power.

When you turn on the power, the billboard lights will come on.

After the GAME LOGO start up screen is displayed on the LCD screen, the Advertise (Attract) Mode will start.

The decorative LEDs (wave effect) at the base of the cabinet will illuminate and fade in/out.

Start up sounds are output from the speakers on the front of the cabinet (Door and Cannon) together with display of the GAME startup screen.

Even when the power source has been cut off, credit count, ranking data, game settings and bookkeeping data are kept stored in the product. However, fractional coin counts (inserted coins that do not amount to one credit) and bonus adder counts are not kept.

## COMPONENTS WHICH CHANGE STATE WHEN POWER IS APPLIED

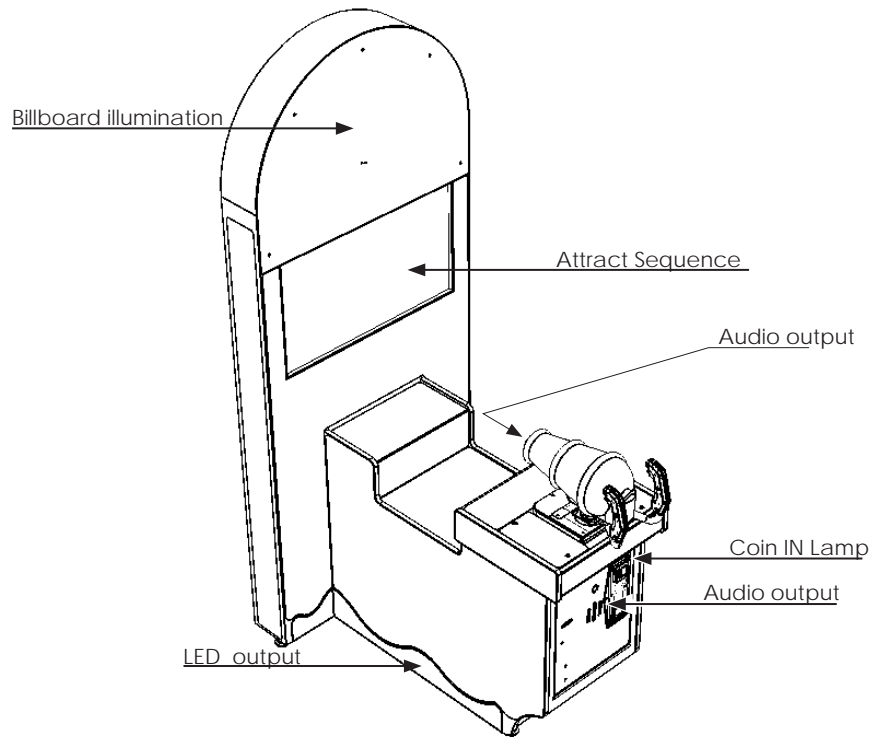

## **7** PRECAUTIONS WHEN MOVING THE MACHINE

### **WARNING**

- Always disconnect the power cable before moving the product. If it is moved with the power cable connected, the cable could be damaged, causing fire or electric shock.
- To move the unit over the floor, pull in the adjusters and have the casters contact the floor. While moving the unit, be careful that the casters do not roll over the power cord or the ground wire. If cord or wire is damaged, there could be electrical shocks and/or short circuits.
- When crossing a sloped or stepped area, always have the machine travel lengthways. Travelling with the machine in a sideways position could result in the machine falling over onto its side. Always use a minimum of two people working together plus lifting apparatus to accommodate sloped areas or stairs.
- To lift up the cabinet, hold it at the bottom at the designated lifting points. If you hold it anywhere else, the weight of the cabinet could cause damage to parts or attachments, resulting in injury.
- Do not push the cabinet from the side when moving. Pushing from the side as it may result in the cabinet falling over.

### **IMPORTANT**

- When moving the cabinet, do not grip or push the Billboard Plate. Doing so could deform or damage the part.
- If moving through a door or place with a low ceiling such as an elevator, you should take apart the billboard and billboard plate.



## 7-1 PRECAUTIONS WHEN MOVING FROM SITE

### STOP IMPORTANT

- When moving the cabinet, do not grip or push the Billboard Plate. Doing so could deform or damage the part.
- If moving through a door or place with a low ceiling such as an elevator, you should take apart the billboard and billboard plate.

Detailed instructions for removing the Assy Billboard and Billboard Plate can be found in Chapter 6 of this manual. Please follow these instruction in reverse order for removal.

Ensure that the casters come into contact with the floor before moving.

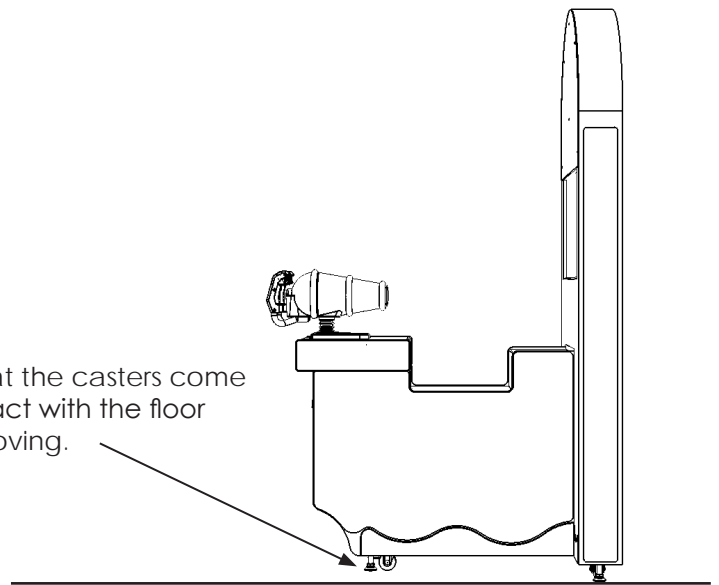

Remove the Billboard and Billboard Plate when transporting the machine in and out of buildings or when passing through areas with low ceilings.

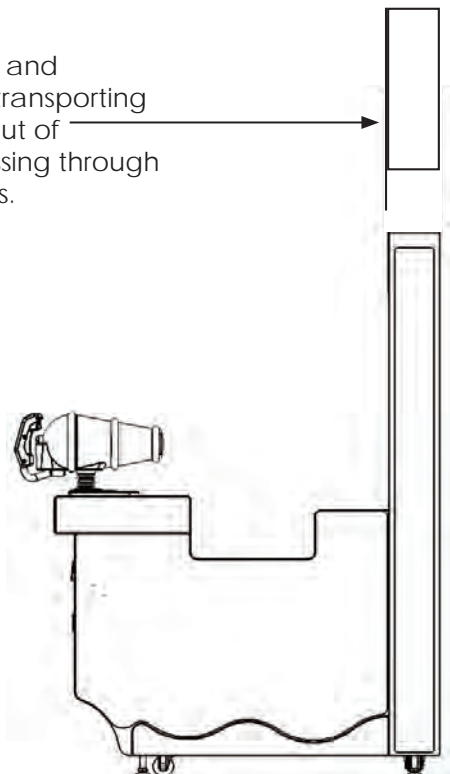

## 8 GAME DESCRIPTION

### 8-1 GAME OUTLINE

Pirates Of Monster Island is a physics based redemption shooting game. Players must use their skill to aim and time their shots to knock items into the sea from passing ships. Tickets are paid out to the player as soon as they are awarded the game play is of a continuous nature.

#### HOW TO PLAY

Once credit(s) have been inserted the player is informed the number of shots that they have available (This is configurable in the Test menu). The aim of the game is to shoot the monsters out of the cannon to knock boxes into the sea. A continuous stream of ships will pass from right to left loaded with a number of boxes. The player must aim and time their shots to successfully hit the boxes. The amount of shots remaining are displayed on their targeting reticule. The passage of ships is continuous even when no credits are inserted.

#### BOX TYPES

1. Standard Box (Various colours) – When these boxes are knocked into the water these fill the “Dragons Den” gauge shown on the left hand side of the screen. When this gauge is full the layer will be taken to the bonus “Dragons Den” game.
2. Explosive boxes (Contain a bomb) – When hit these will explode causing all boxes nearby to be blown away. Hitting these boxes is the key to winning and is prompted to the player in the attract sequence.
3. Letter Boxes – These boxes contain letters. Once knocked into the water these fill the word “THE COMPASS” at the bottom of the screen. Once all the letters are lit the player is awarded a “spin” of the bonus compass wheel.
4. Ticket Boxes (Contains a ticket) – When these boxes are knocked into the water the player is awarded (a) ticket(s) dependant on the payout settings chosen in the Test Menu.
5. In addition there are enemy characters on some ships that can also be knocked into the sea (But not killed or injured) successfully knocking them into the sea will award the player a ticket.

#### DISTRACTIONS

If the player shoots an Explosive Box and the “XXXX” option is enabled in the test menu then a distracting character will “pop” into view at the side of the screen. These characters cannot be “shot” and will disappear if targeted. They are designed to act as a distraction to the player who will waste shots attempting to shoot them. These can be disabled in the test menu.

## DRAGONS DEN FEATURE

The Dragons Den Gauge, located on the left hand side of the screen is filled by the player knocking coloured standard boxes into the sea. The gauge has an optional numerical counter that can be disabled in the test menu. This gauge is persistent across credits but will slowly decrease over time. (Operator configurable). If the player successfully fills the gauge then they will be taken to the “Dragons Den” bonus game. This is a timed bonus level where three circling dragons clutch baskets containing lots of boxes for the player to target. If the player breaks a basket then the contents fall into the sea below. When a basket is broken the dragon will fly off to be replaced by a new dragon carrying a new basket.

## THE COMPASS FEATURE

IF the player successfully lights all of the letters of “THE COMPASS” shown at the bottom of the screen they are awarded one spin of the Compass wheel. The lit wheel feature will begin to spin and stop at a single value. If the compass feature is awarded in the Dragons Den bonus game then the spin(s) will be shown once they return to the standard game. In the case of multiple spins the will be shown consecutively. During a spin the player is free to continue shooting as no user input is required. The awards are based on the pay out settings selected in the test menu but the items are as follows:

LOSE: No award

WIN TICKETS: ticket(s) are awarded

CHANCE: A rapidly moving ruby gem moves across the screen. If the player shoots the gem they receive a ticket bonus

SUPER BONUS: The player is awarded the “SUPER BONUS” ticket payout

## GAME OVER

The player is informed that they have no remaining shots but “GAME OVER” is not announced. The player has the opportunity to add more credits and “continue” where they

## 9 EXPLANATION OF TEST AND DATA DISPLAY

Perform tests and data checks periodically by manipulating the TEST Button and SERVICE Button in the cabinet. Follow the instructions in this chapter to conduct checks when the game machine is first installed, when money is being collected, or when the game machine does not operate properly.

Shown overleaf are the tests and screens to be used for different problems.

### **STOP** IMPORTANT

- When changing the game configuration within the TEST MODE, be sure to exit all screens in the correct manner by choosing exit. DO NOT turn the machine ON/OFF to resume game. Changes WILL NOT take effect unless the correct method is used.

**9-1 SWITCH UNIT AND COIN METER.**

**⚠ WARNING**

Never touch places other than those specified. Touching places not specified can cause electric shock and short circuit accidents.

**STOP IMPORTANT**

- Adjust the sound to the optimum volume, taking into consideration the environmental requirements of the installation location.
- Removing the Coin Meter circuitry renders the game inoperable.

**9-1-1 SWITCH UNIT**

Open the coin chute door, and the switch unit shown will appear.  
The functioning of each SW is as follows:

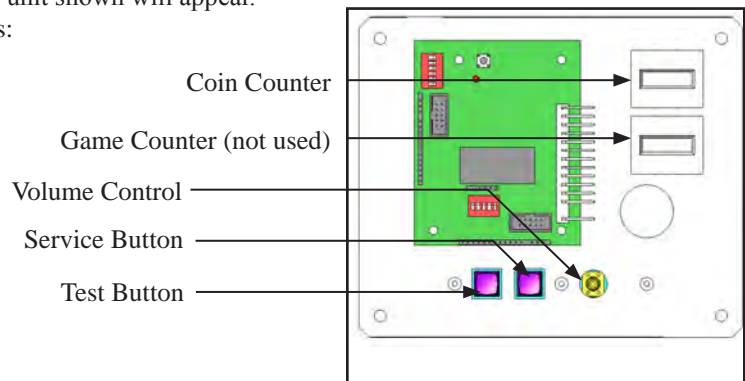

**9-1-1 FIG. 01**

|                                     |  |
|-------------------------------------|--|
| TEST Button (TEST):                 | For the handling of the Test Button, refer to the following pages. |
| SERVICE Button (SERVICE):           | Gives credits without registering on the coin meter.               |
| Sound Volume Switch (SOUND VOLUME): | Adjust sound volume for all of the machines' speakers.             |
| Coin Counter                        | Counts and displays coins in \$0.10 units.                         |
| Game Counter (if fitted)            | Counts games played  |

## 9-2 TEST MODE

### STOP IMPORTANT

The details of changes to Test Mode settings are saved when you exit from each Test Mode by selecting EXIT. Be careful because if the power is turned off before that point, changes to the settings will be lost.

Opens the Game Test Mode, allowing game specific settings and tests to be performed. This option will be displayed in grey until preparations are complete. Select the Game Test Mode option to begin the game test.

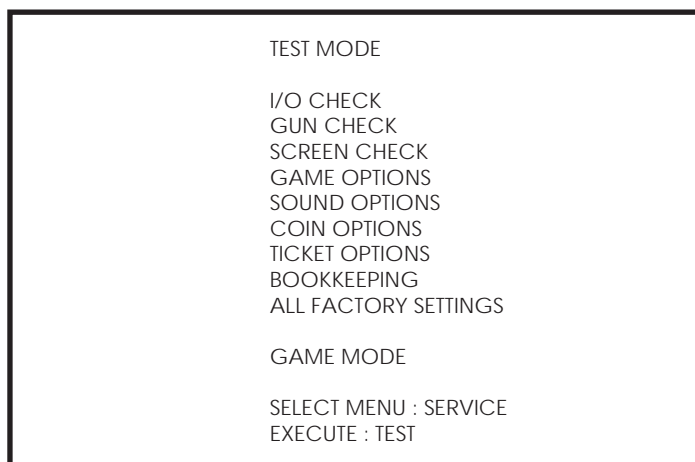

The following options are available from the Game Test Mode.

Use the SERVICE button to move the cursor to the desired test item.

Press the TEST button to enter the selected item.

#### Menu details

|                      |  |
|----------------------|--|
| I/O CHECK            | Test all player controls & switches.   |
| GUN CHECK            | Check the graphics functions.  |
| SCREEN CHECK         | Checks the color & clarity of the monitor.   |
| GAME OPTIONS         | Adjusts the game settings  |
| SOUND OPTIONS        | Adjust the game volume and tests the speakers.   |
| COIN OPTIONS         | Change price per game options.   |
| TICKET OPTIONS       | Checks the NETWORK-ID and the connections.   |
| BOOKKEEPING          | View the history of game play.   |
| ALL FACTORY SETTINGS | Resets all changes made to the game to factory settings<br>Not all settings will be reset<br>For details, please referee to the "ALL FACTORY SETTINGS" page. |
| GAME MODE            | Return to normal game play.  |

## 9-3 I/O CHECK

### INPUT CHECK

Using the SERVICE button to select I/O CHECK and press the TEST button to enter the selected item.

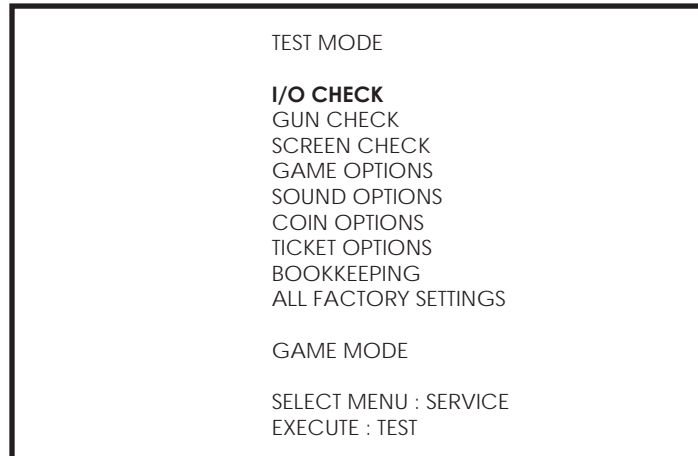

Selecting the I/O CHECK screen from the TEST MODE menu will display the I/O CHECK screen.

Use the SERVICE button to select INPUT CHECK

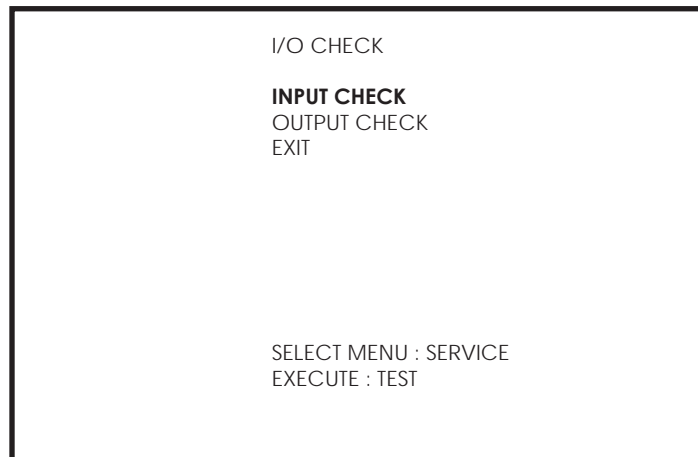

This menu is used to test the System Inputs such as GUN, COINS and SWITCHES. To implement the test, activate each device that is listed and check the results on screen.

Press TEST to EXIT back to the I/O CHECK screen

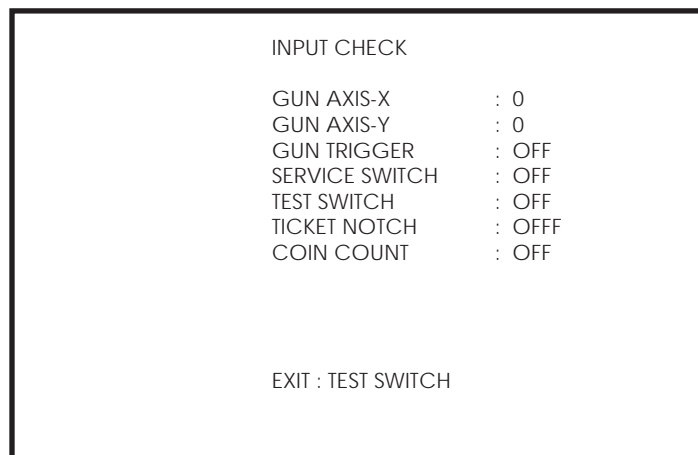

## OUTPUT CHECK

Use the SERVICE button to select OUTPUT CHECK and press TEST to execute.

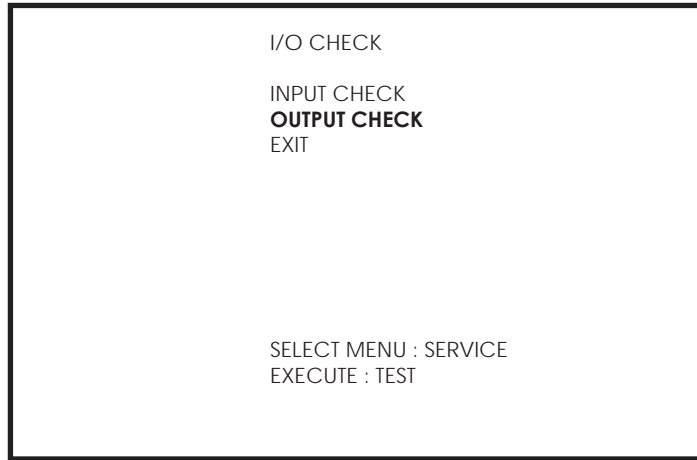

This test is used to check the System Output on the Lamps in the cabinet.

Use the SERVICE button to move the cursor to the desired test item.  
 Press the TEST button to test the selected item.

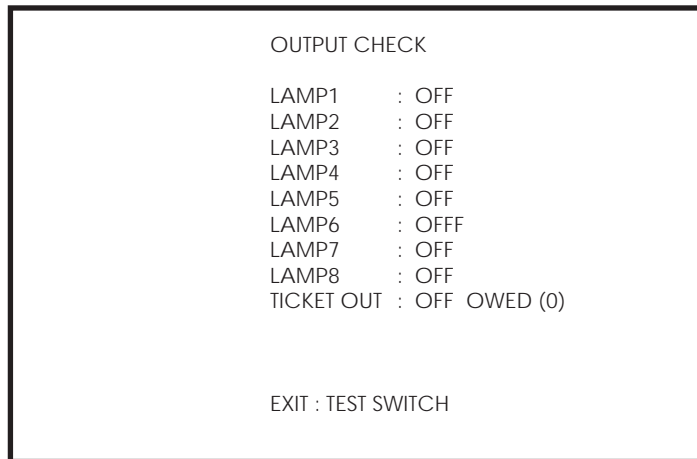

LAMP1 – ON = Lamp ON, OFF = Lamp OFF.

LAMP2 – ON = Lamp ON, OFF = Lamp OFF.

LAMP3 – ON = Lamp ON, OFF = Lamp OFF.

LAMP4 – ON = Lamp ON, OFF = Lamp OFF.

LAMP5 – ON = Lamp ON, OFF = Lamp OFF.

LAMP6 – ON = Lamp ON, OFF = Lamp OFF.

LAMP7 – ON = Lamp ON, OFF = Lamp OFF.

LAMP8 – ON = Lamp ON, OFF = Lamp OFF.

TICKET OUT – ON = TICKET ON, OFF =TICKET OFF.

EXIT – Press the Test button to return to the I/O CHECK screen.



## 9-4 GUN CHECK

Use the SERVICE button to select GUN CHECK and press TEST to execute.

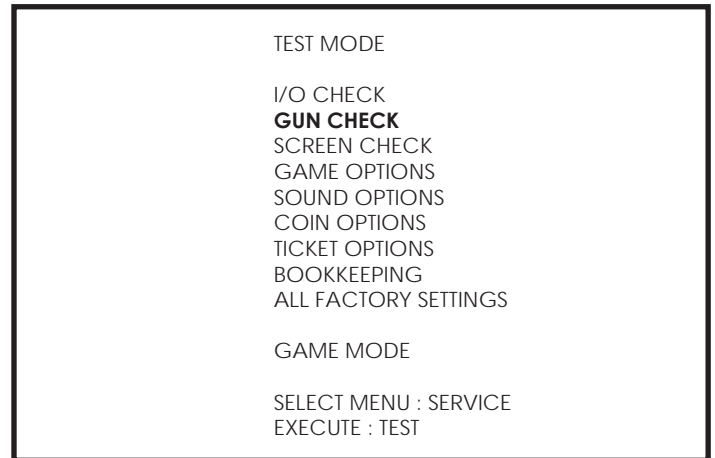

Use the SERVICE button to select CALIBRATION and press TEST to execute.

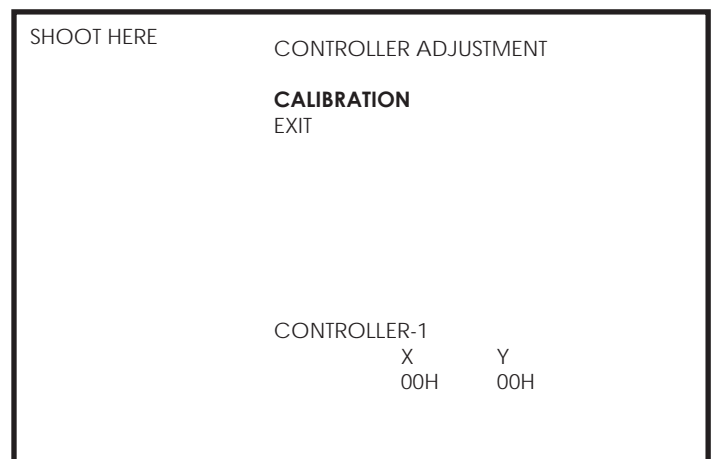

To calibrate the controller - aim the cannon at "SHOOT HERE" and press the trigger to initiate. Follow the procedure for each corner of the screen.

EXIT - Press the TEST button to exit and return to the TEST MODE screen.

## 9-5 SCREEN CHECK

Use the SERVICE button to select SCREEN CHECK and press TEST to execute.

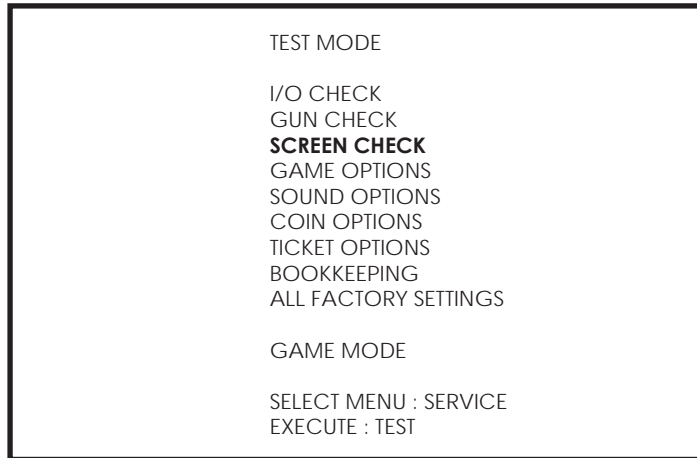

Use the SCREEN CHECK to check the setting on the LCD display and make any adjustments to suit the environment, e.g light conditions. Please refer to Chapter 10 on instructions on how to adjust screen.

### COLOR BAR SCREEN

Press the SERVICE button to change to CROSSHATCH screen.



### CROSS HATCH SCREEN

Press the SERVICE button to change to COLOR BAR screen

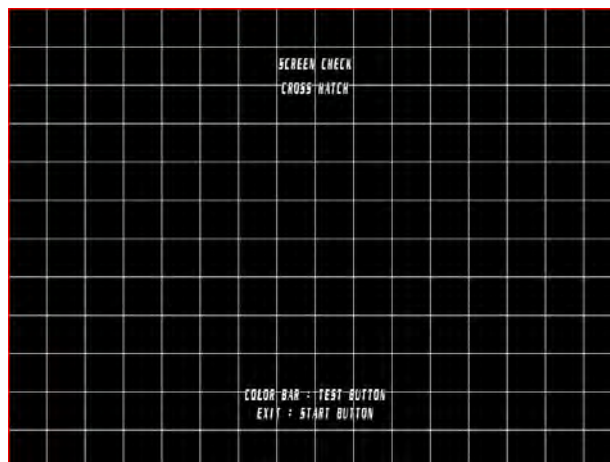

EXIT - Press TEST button to return to TEST MENU screen.

## 9-6 GAME OPTIONS

Use the SERVICE button to select GAME OPTIONS and press TEST to execute.

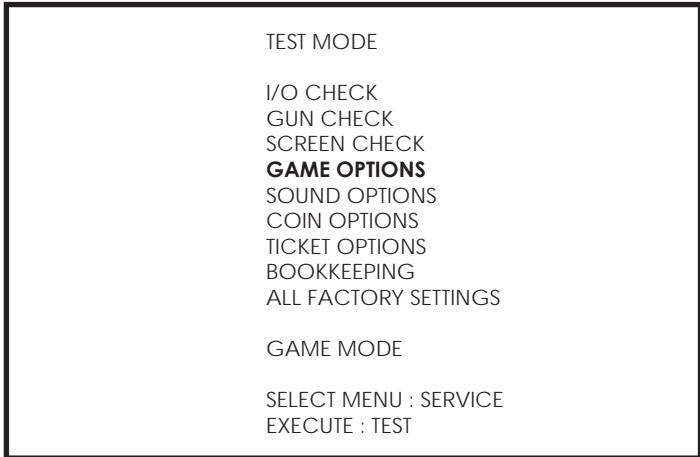

Use the SERVICE button to highlight each game option and press TEST amend value.

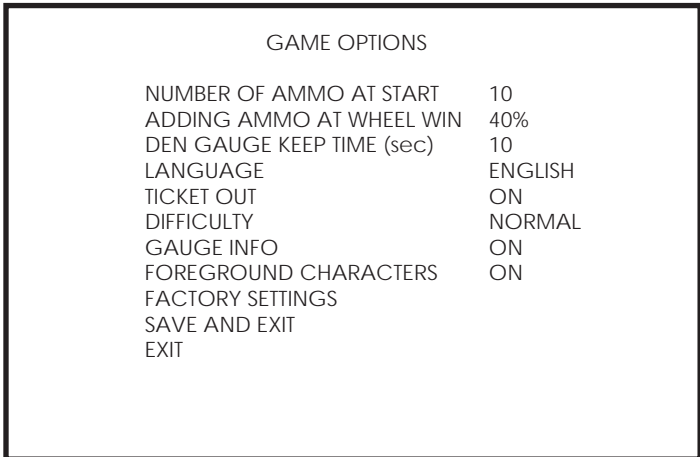

- NUMBER OF AMMO AT START : Number of adding ammo per credit.
- ADDING AMMO AT WHEEL WIN : Number of adding ammo at wheel spin ammo bonus.
- DEN GAUGE KEEP TIME(sec) : Time until DEN gauge begins to decrease,
- TICKET OUT : A ticket will not come out if this is set to OFF.
- DIFFICULTY : 1: EASIEST 2: VERY EASY 3: EASY 4: NORMAL 5: HARD  
6: VERY HARD 7: HARDEST
- GAUGE INFO : DEN gauge numeric information ON/OFF
- FOREGROUND CHARACTERS : Foreground enemy character ON/OFF in game
- FACTORY SETTINGS : Resets all changes made to the game to factory settings.
- SAVE AND EXIT : Save all changes and return to MAIN MENU.

\*Please Note: for changes to be saved you must select "SAVE AND EXIT". If "SAVE AND EXIT is not selected the any changes made in this screen will be lost.

EXIT - Press TEST button to return to the TEST MENU screen.

## 9-7 SOUND OPTIONS

Use the SERVICE button to select SOUND OPTIONS and press TEST to execute.

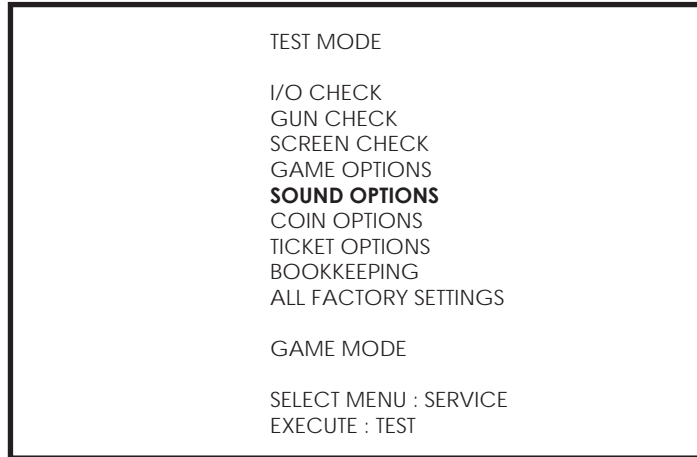

Use the SERVICE button to select SOUND OPTIONS and press TEST to execute.

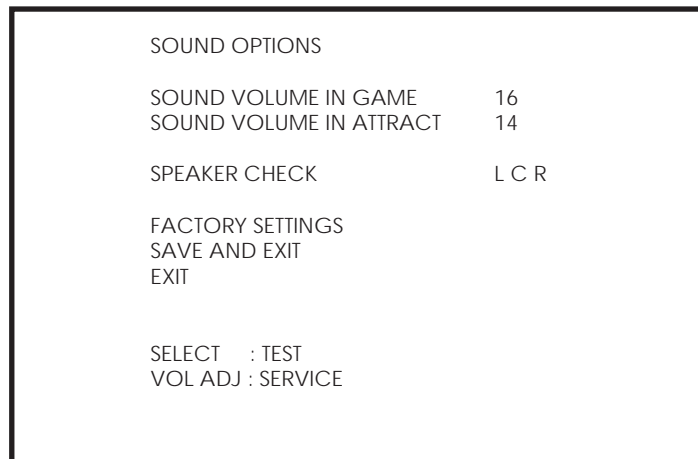

Adjust the volume during game play and attract mode. To navigate - use the below controls

- |                              |   |   |
|------------------------------|---|---|
| SERVICE BUTTON               | : | Scroll through selection  |
| SOUND VOLUME IN GAME MODE    | : | The overall volume level of the game play.  |
| SOUND VOLUME IN ATTRACT MODE | : | The level of volume audible to attract players while in attract mode.                   |
| SPEAKER CHECK                | : | Checks each speaker for correct orientation & clarity<br>L (left)- C (both) - R (right) |
| FACTORY SETTINGS             | : | Restores values to original factory settings  |
| SAVE AND EXIT                | : | Saves changes made  |

EXIT - Press TEST button to return to TEST MENU screen

## 9-8 COIN OPTIONS

Use the SERVICE button to select COIN OPTIONS and press TEST to execute.

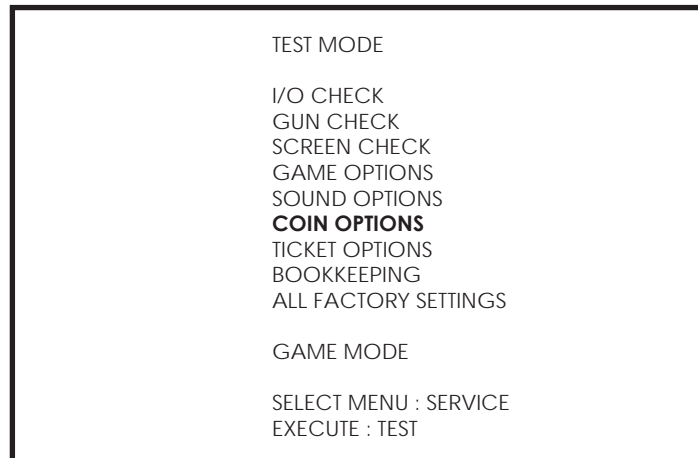

Use the SERVICE button to highlight each option and press TEST ammend value.

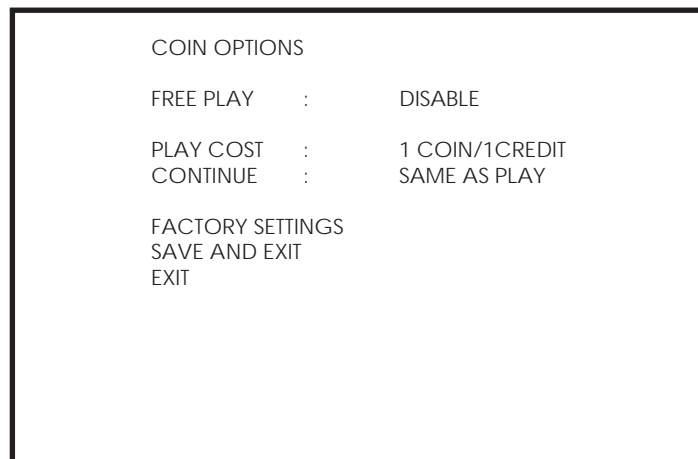

- FREE PLAY : DISABLE/NORMAL PLAY - ENABLE/FREE PLAY
- PLAY COST : The number of credits given per coin inserted.
- CONTINUE : *This is not available in this game.*
- FACTORY SETTINGS : Resets all changes made to the game to factory settings.
  
- SAVE AND EXIT : Save all changes and return to MAIN MENU.
- EXIT

EXIT - Press TEST button to return to the TEST MENU screen.

## 9-9 TICKET OPTIONS

Use the SERVICE button to select TICKET OPTIONS and press TEST to execute.

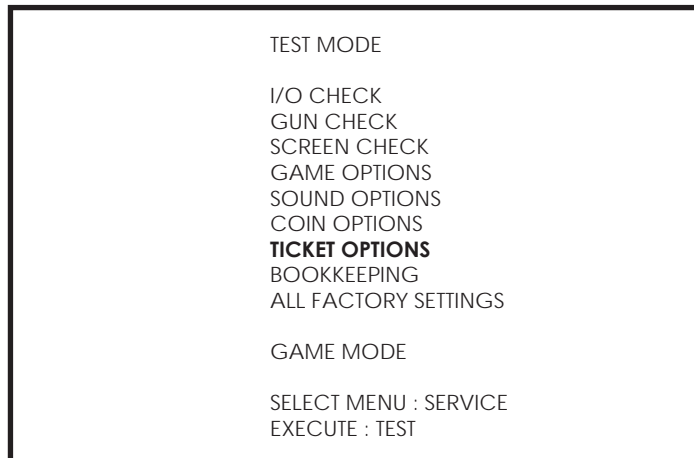

TICKET OPTIONS configures the settings for redemption tickets.

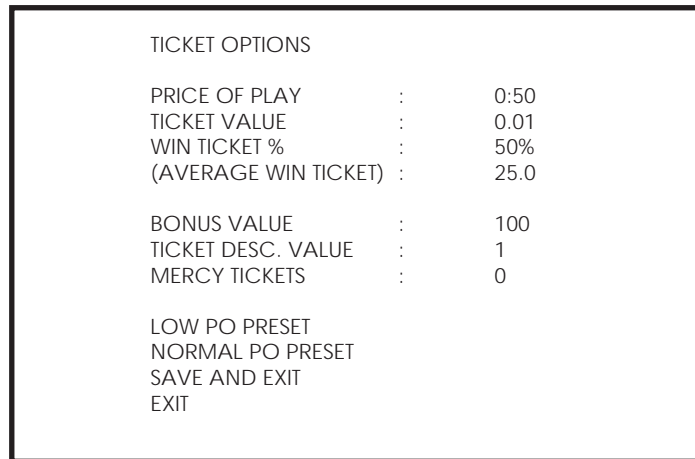

PRICE OF PLAY : Set the cost to play 1 game.  
 Used to display payout rate, does not affect actual game.

TICKET VALUE : Set the value of 1 ticket.  
 TICKET TICKET PERCENTAGE : Set the ticket payout percentage.  
 BONUS VALUE : Set the super bonus ticket value.  
 TICKET DESC. VALUE : Ticket description value of 1 ticket.  
 MERCY TICKET : Number of mercy ticket.

SAVE AND EXIT : Save all changes and return to MAIN MENU.  
 EXIT

EXIT - Press TEST button to return to the TEST MENU screen.

## 9-10 BOOKKEEPING

Use the SERVICE button to select BOOKKEEPING and press TEST to execute.

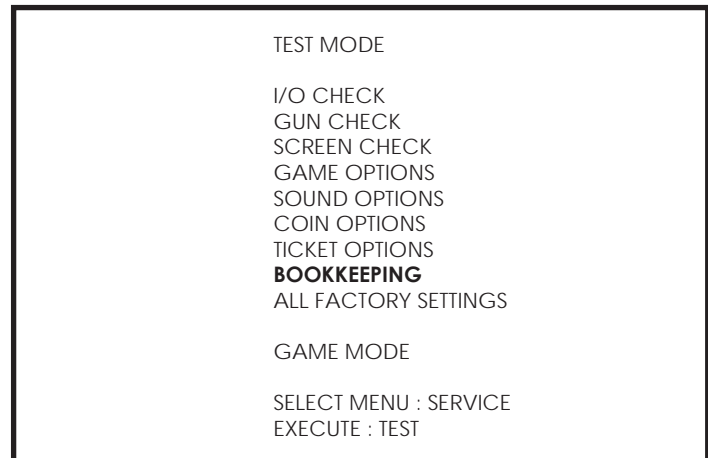

View the history of game play and change time and date. Any play data will not be saved before date and time is set. Please make sure the time and date is correct.

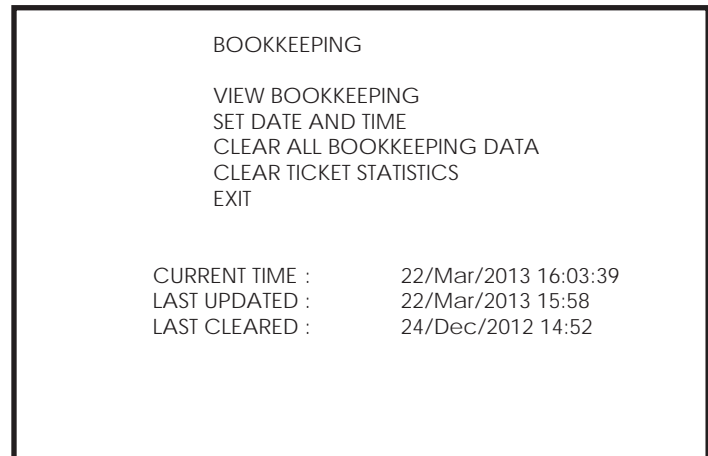

SET DATE & TIME : Set the machines clock.  
contents  
YYYY - Year  
MM - Month  
DD - Day  
HH - Hours  
MM - Minutes

CLEAR ALL BOOKKEEPING DATA: Clears the machines history.  
CLEAR TICKET STATISTICS : Clear only ticket payout statistics.

EXIT - Press TEST button to return to the TEST MENU screen.

**VIEW BOOKKEEPING**

Visual display of the machine bookkeeping records.

| BOOKKEEPING        |          |
|--------------------|----------|
| COIN IN            | 0        |
| SERVICE COIN IN18  |          |
| TOTAL PLAYS        | 39       |
| INITIAL START      | 20       |
| TOTAL PLAY TIME    | 0h18m18s |
| AVERAGE PLAY TIME  | 0m27s    |
| SHORTEST PLAY TIME | 0m01s    |
| LONGEST PLAY TIME  | 1m51s    |
| INCOME HISTORY     |          |
| TODAY              | 0        |
| YESTERDAY          | 0        |
| 2 DAYS AGO         | 0        |
| 3 DAYS AGO         | 0        |
| 4 DAYS AGO         | 0        |

|                     |   |                                |
|---------------------|---|--------------------------------|
| COIN IN             | : | Total Coins In                 |
| SERVICE COIN IN     | : | Count of service credit        |
| TOTAL PLAY          | : | Count of total plays           |
| INITIAL START       | : | Number of initial play counts  |
| CONTINUE PLAY COUNT | : | Number of continue play counts |
| TOTAL PLAY TIME     | : | Total playing time             |
| AVERAGE PLAY TIME   | : | Average playing time per play  |
| INCOME HISTORY      | : | Last 8 days income             |
| MONTHLY TOTAL       | : | Monthly income                 |

WIN TICKET PERCENTAGE : Current ticket payout percentage.  
 Once you change the TICKET OPTIONS settings, this parameter will not be accurate until you clear TICKET STATISTICS.



## 9-11 ALL FACTORY SETTINGS

Use the SERVICE button to select ALL FACTORY SETTINGS and press TEST to execute.

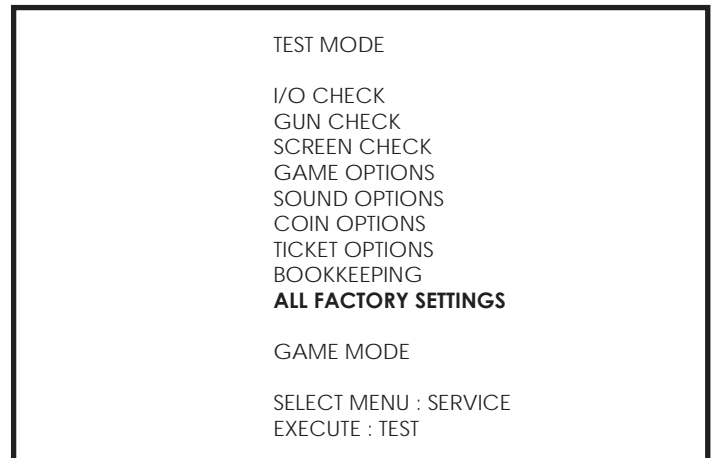

Will rest all setting made with the exception of the following:

BOOKKEEP DATA

I/O CALIBRATION DATA

Use the SERVICE button to select GAME MODE and press TEST to return to the GAME.

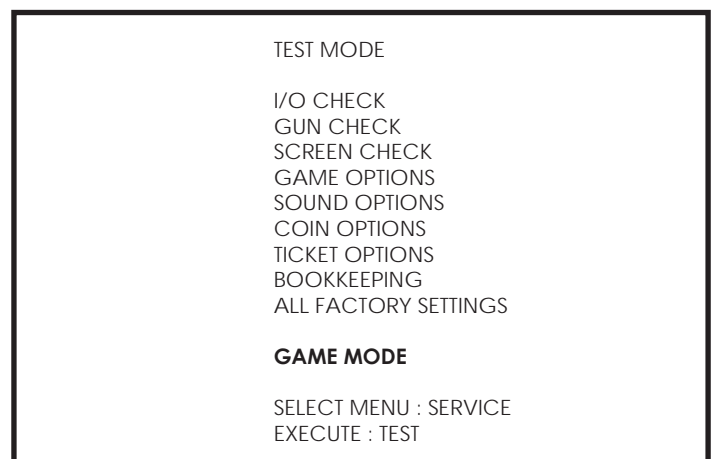

## 10 CONTROLLER UNIT(S), SWITCHES AND BUTTONS

### WARNING

- When working with the product, be sure to turn the power off. Working with the power on may cause an electric shock or short circuit.
- Be careful not to damage the wires. Damaged wires may cause an electric shock, short circuit or present a risk of fire.
- Exercise due caution in performing soldering work. If soldering iron is handled carelessly, there could be fires or burns.

### CAUTION

- When fastening plastic parts, be careful not to tighten screws or nuts excessively. If these are tightened to excess, parts could be damaged, resulting in injuries from fragments, etc.
- After the unit has been disassembled and reassembled again, check carefully that the unit has been reassembled correctly.
- Be sure to inspect the outer covers on both gear and hand brake units.
- Assemble so that there is no gap between the L and R covers. If there is a gap or rattling, the players could get fingers or hands caught, resulting in injury.

### IMPORTANT

- Once the product has been disassembled, use slack preventive agent (product No. : 090-0012-N). Coat screws with suitable amounts of this agent and then tighten them. If this agent is not used, the product might start rattling or come apart.
- Use the slack preventive agent prescribed in these instructions. If any other agent is used, there could be chemical changes that inhibit the use of screws and part surfaces could be damaged.
- Be careful not to damage or lose small parts or screws.
- When a part has been replaced, be sure to always make adjustments and check conditions in Test Mode.

## 10-1 REMOVING THE CONTROLLER

### STOP IMPORTANT

Be sure to disconnect the power from the machine before performing any work. Failure to remove the power may result in electric shock or component damage.

- 1 Turn off the power. Remove the 2x screws from the small finger trap plate located at the front of the Canon base. Remove plate.

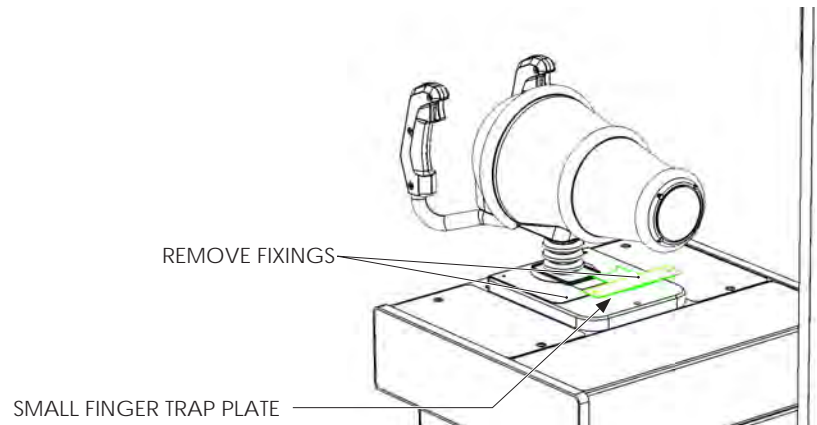

- 2 Remove the 2 screws from the finger trap plate located at the rear base of the controller. Remove plate.

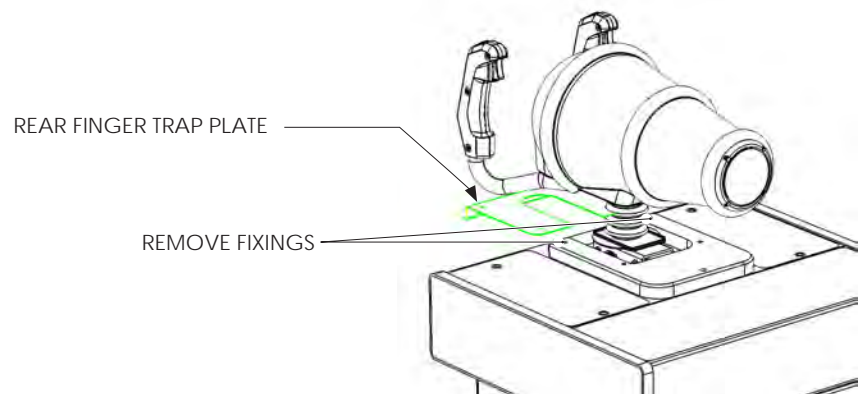

- 3** Remove the 4 screws which secure the Control Panel to the cabinet.

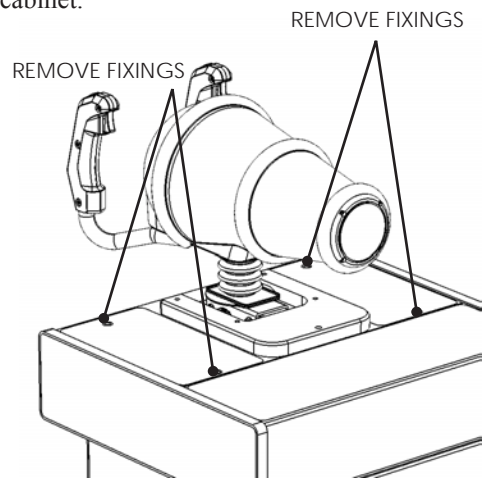

- 4** Carefully slide out the Controller Base and Control Panel in opposite directions as illustrated.

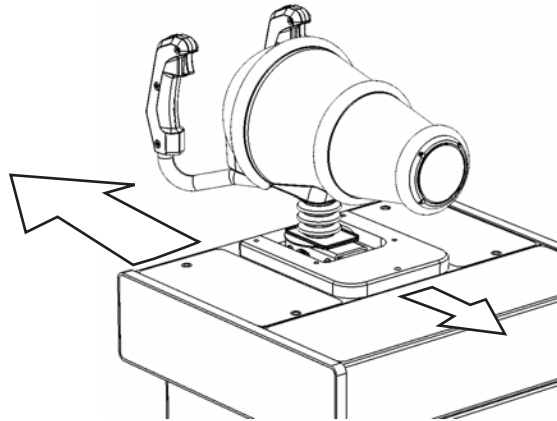

- 5** Remove the 4x M8 Hex Bolts located at the base of the Controller. Take care in disconnecting the Controller Harness and remove the controller.

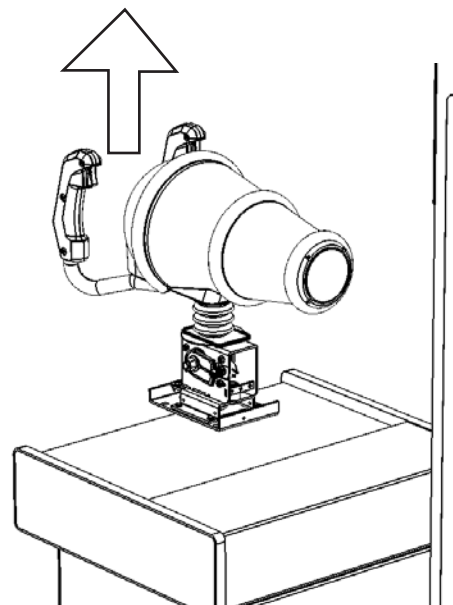

## STOP IMPORTANT

Be sure to perform volume's move value setting in the INPUT ASSIGNMENTS in the Game Test Mode after replacing or adjusting the Volume.

### 10-2 ADJUSTING/REPLACING THE VOLUME POT

#### ADJUSTMENT PROCEDURE

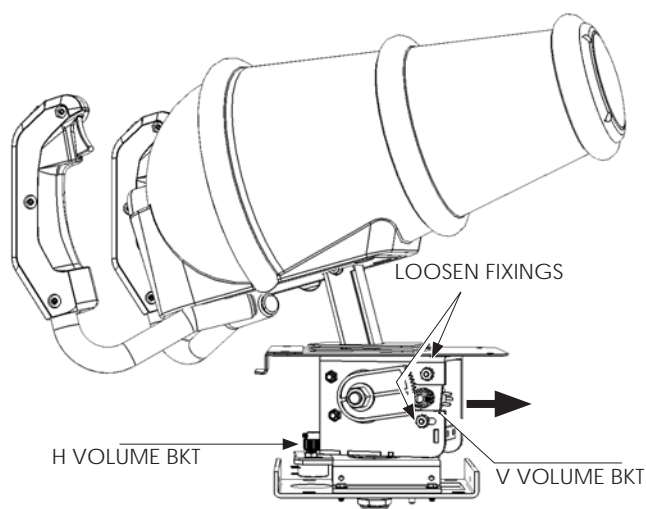

- 1** Apply this procedure to both Horizontal and Vertical Volume Pots. Loosen the 2 screws that secure the VR Bracket and move the VR Bracket to adjust the angle and condition of the gear alignment.
- 2** Locate the central position of the pot by turning the pot in both clockwise and counterclockwise positions. Once a central position of the pot has been determined, straighten the handle so that the gear is positioned horizontally. Slide the pot into position engaging the gears.
- 3** Tighten the 2 screws and secure the VR Bracket and refit the cover.
- 4** Check to make sure the value on the Input Test screen is within the range  $80H \pm 8H$  when the steering unit is in the straight position.

## REPLACEMENT PROCEDURE

This procedure requires the following tools: Phillips screwdriver for the M4 screws, 1.5 mm hexagonal wrench, 11-12 mm monkey wrench, nipper, cutter, wire stripper, soldering iron, industrial dryer and heat-shrinkable tube.

- 1 Remove the connectors.
- 2 Remove the 2 screws securing the VR Bracket and remove the entire Bracket and V.R. (See previous instruction)
- 3 Loosen the 1 hexagon socket screws on the Gear Holder and remove the Gear Holder.
- 4 Remove the nut securing the VR Bracket, then separate the Volume from the VR Bracket and replace it.
- 5 Check to make sure the value on the Input Test screen is within the range  $80H \pm 8H$  when the steering unit is in the straight position.

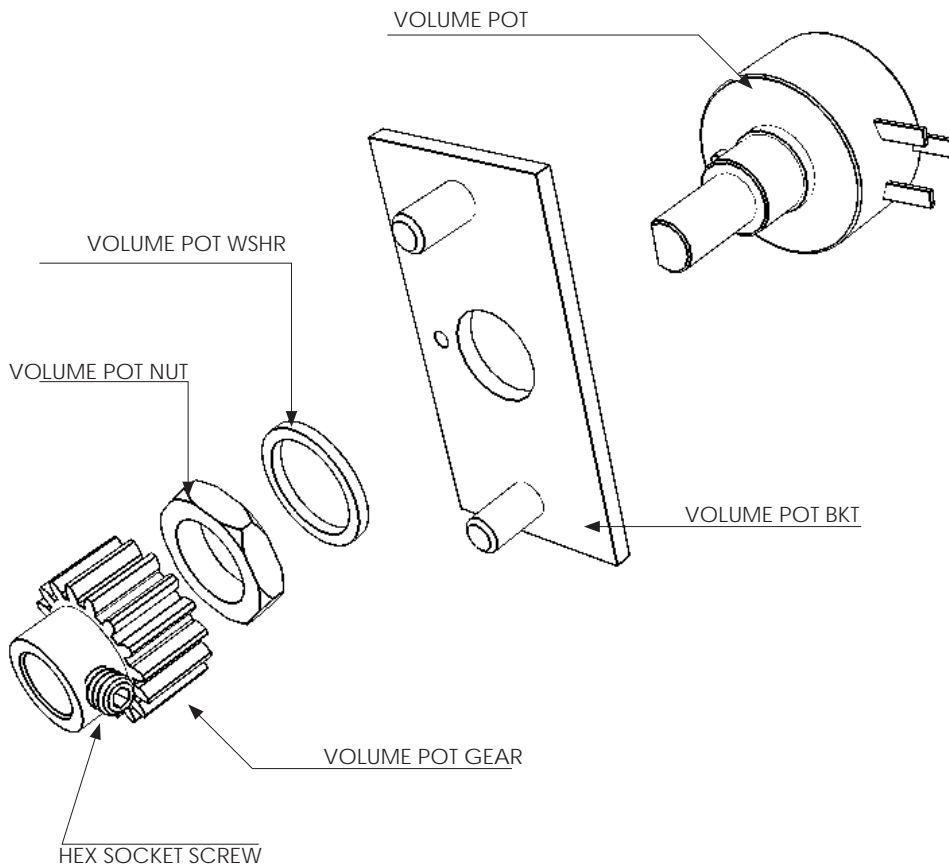

- 
- 6** The wire connected to the volume pot will be reused. Use a tool such as a pair of snips or cutters to remove the old heatshrink tubes which cover the contacts.
- 
- 7** Use a soldering iron to melt the solder and separated the wires from the old volume pot. Be very careful when using a soldering iron.

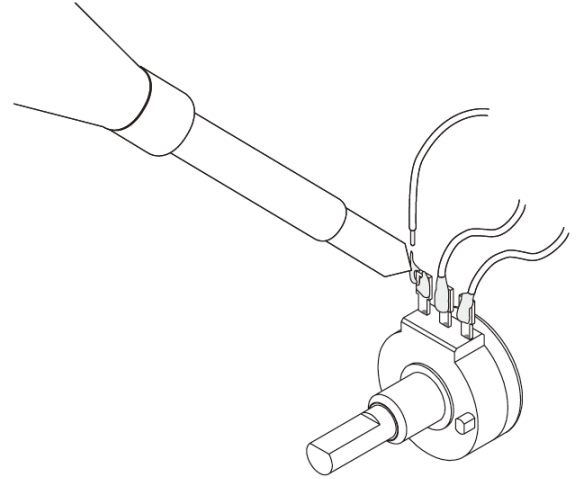

- 
- 8** If the exposed conductive wire at the end is less than 5mm, use a tool such as a wire stripper or cutter to cut the wire insulation back to a workable length. Place new sleeving over the wire before resoldering them to the pot.
- 
- 9** Once soldered, cover the bare contacts with the sleeving. If heatshrink is used, apply heat from an appropriate hot air blower to shrink the sleeving tightly over the contacts.
- 
- 10** Reassemble the pot to the pot bracket by working in reverse order of these instructions. Refer to the POT VOLUME ADJUSTMENT section of this manual.

## 10-3 GREASING

### STOP IMPORTANT

- Be sure to use the designated grease. Using undesignated grease can cause parts damage.
- Do not apply grease to locations other than as specified. Doing so may create a risk of operational problems and deterioration of parts.
- The designated periods for greasing serve only as a guide. Whenever there are squeaks or other anomalies, apply grease at designated locations.

Use spray grease once every three months to grease up the gear mesh portion of the constituent parts.  
Use "Grease Mate" (part number 090-0066) for the spray grease.

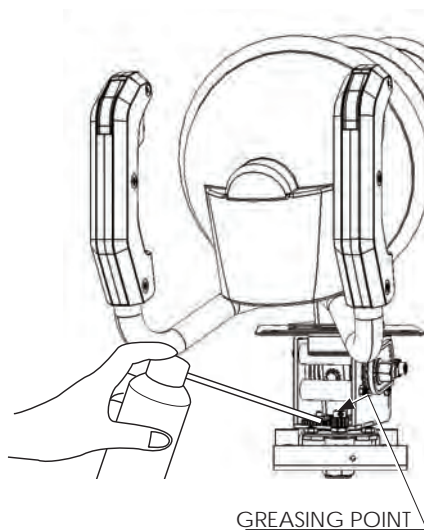
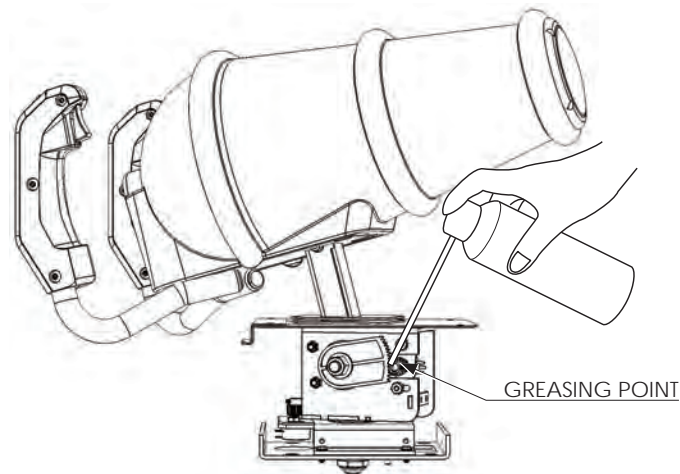



## 11 LCD DISPLAY (VGA)

### 11-1 SAFETY PRECAUTIONS WHEN HANDLING THE MONITOR

#### WARNING

Responding to breakdown or abnormality

- If smoke or a strange odor appears, immediately unplug the power cable from the power source.

Continuing to use the product may cause a fire or an electric shock. Ensure that smoke is no longer emitted, and contact the point of purchase.

- If nothing displays on the screen, immediately unplug the power cable from the power source.

Continuing to use the product may cause a fire or an electric shock. Contact the point of purchase and request an inspection.

- If water or a foreign object enters the monitor's interior, immediately unplug the power cable from the power source.

Continuing to use the product may cause a fire or an electric shock. Contact the point of purchase and request an inspection.

- If the monitor is dropped or the cabinet is damaged, immediately unplug the power cable from the power source.

Continuing to use the product may cause a fire or an electric shock. Contact the point of purchase and request an inspection.

During operation

- Do not repair, reconstruct, or disassemble the monitor.

The monitor's interior contains high voltage parts. A fire or an electric shock could result.

For inspections, adjustments, and repair of the monitor's interior, request work from the point of purchase.

- Do not insert foreign objects.

If metal objects or flammable materials such as paper are inserted into the interior through ventilation openings or other apertures, an electric shock could result.

- In the event of a thunder storm, do not touch the product or the power cable. An electric shock could result.

- Make sure to perform appropriate adjustments. Do not operate the product when the screen is flickering, distorted, or experiencing other abnormalities. Images from an improperly adjusted screen could cause players and other customers to experience dizziness, headaches, and other ailments.

## 11-2 CLEANING THE SCREEN SURFACE

### CAUTION

- Use a soft, dry cloth (flannel-type) to wipe away dirt. Do not use materials such as coarse mesh gauze.
- Alcohol (ethanol) is the recommended solvent for removing dirt. When using a cleaning agent, follow the precautions below.
  - Dilute neutral cleaning agents for home use with water. Soak a soft cloth in the solution, and wring it thoroughly before wiping the screen.
  - Do not use abrasive cleaning agents or powders, or cleaning agents containing bleach.
  - Do not use alkaline cleaning agents such as glass cleaners, or solvents such as thinners.
- Do not scrub or scratch the screen surface with abrasive materials such as brushes or scrub brushes.

**CLEAN THE SCREEN DAILY.**

## 11-3 ADJUSTMENT METHOD

### **STOP** IMPORTANT

All adjustment values are set accurately at the time of shipping from the factory. Do not readjust these values needlessly or apply adjustments not specified in this manual. The display may not appear properly if the values are incorrect.

### CONTROL - ADJUSTMENT PROCEDURE

This sections explains basic control procedures for making adjustments using the buttons on the 'Monitor Adjustment Board'

This Adjustment Board, and the Monitor Power Supply are located behind the Rear Door.

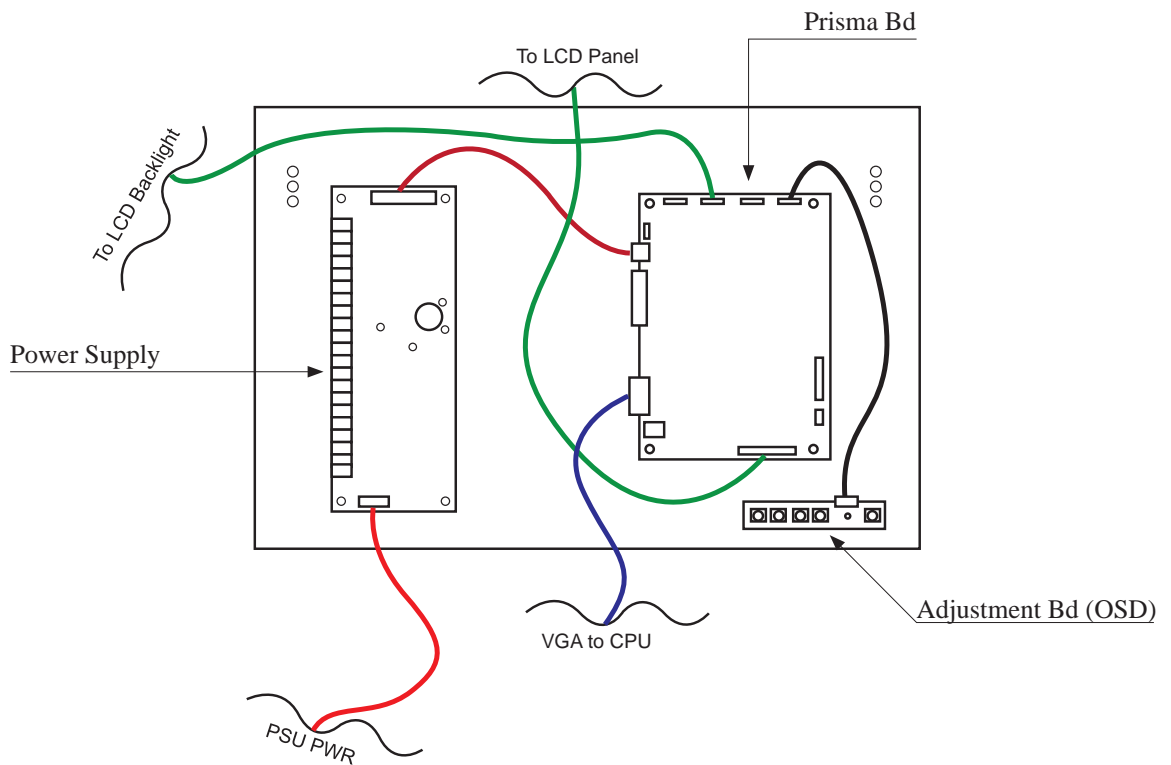

## 11-3 ADJUSTMENT METHOD

### Button Names and Functions

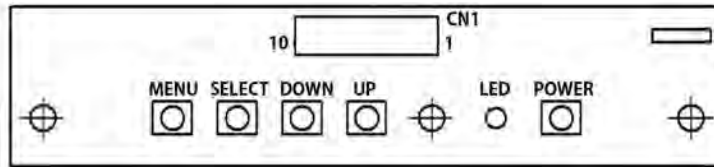

11-3 Fig. 03

**MENU:** Turn the Picture Menu display ON and OFF.

**SELECT:** Gains entry to the Item selected in the menu. (Highlights in Yellow when selected)  
Exits the Item adjustment. Any changes made during this operation are actioned.

**DOWN:** Moves the cursor (Black Bar) down to select a menu item.  
Decrease the value of, or change, a selected menu item.

**UP:** Move the cursor (Black Bar) up to select a menu item.  
Increase the value of, or change, a selected menu item.

**LED:** LED illuminates green: Monitor is operating.  
LED flashes red: Power is off.

**POWER:** Turns the LCD Display ON and OFF. (Usually, it's not necessary to operate.)

## 11-3 ADJUSTMENT METHOD

### On-Screen Display (OSD)

Press the MENU Button while the OSD is not displayed to bring up the Picture Menu.  
On the Picture Menu, it is possible to perform various screen adjustments.



11-3 Fig. 04

Use the UP and DOWN Buttons to move the 'Black Bar' to the item you want to adjust.  
After selecting the desired item, pressing the SELECT Button will extend the MENU Screen and allow adjustments to be changed.

Within each item, press the SELECT Button to exit the adjustment screen. The adjustment values at this time will be saved simultaneously.



11-3 Fig. 05

The current options are set at :

|            |   |       |
|------------|---|-------|
| CSM        | - | 6500K |
| Brightness | - | 100   |
| Contrast   | - | 50    |

## 11-3 ADJUSTMENT METHOD

### On-Screen Display (OSD) <continued>



11-3 Fig. 06

### Available Settings

**CSM** (Selects Operation Mode)  
 Selection available - 6500K - 9300K - USER

**BRIGHTNESS** (Adjust Brightness)  
 Adjust screen Brightness. - Values: 0 - 100  
 (0" being the darkest setting, and "100" being the brightest)

**CONTRAST** (Adjust Contrast)  
 Adjust Contrast level. - Values: 0 - 100  
 (0" having the least amount of difference between light and dark, and "100" having the most)

**NOTE :** The Red, Green, and Blue adjustments are unavailable in the Mode of Operation selected on the Screen shown in 11-3 Fig. 06. These adjustments can only be made is the CSM option is set to 'User'.

## 12 COIN HANDLING

### Handling the Coin Jam

If the coin is not rejected when the REJECT button is pressed, open the coin chute door and open the selector gate. After removing the jammed coin, put a normal coin in and check to see that the selector correctly functions.

12

COIN HANDLING

### 12-1 CLEANING THE COIN SELECTOR

#### STOP IMPORTANT

- Remove and clean smears by using a soft cloth dipped in water or diluted chemical detergent and then squeezed dry.
- Never apply machine oil, etc. to the Coin Selector.
- After cleaning the Coin Selector, insert a regular coin in the normal working status and ensure that the selector correctly functions.

The Coin Selector should be cleaned once every 3 months.  
When cleaning, follow the procedure below:

- 1 Turn the power for the machine OFF. Open the Coin Chute Door
- 2 Remove the Coin Selector from the Coin Chute Door
- 3 Open the gate and dust off by using a soft brush (Small soft Paint Brush, etc.)

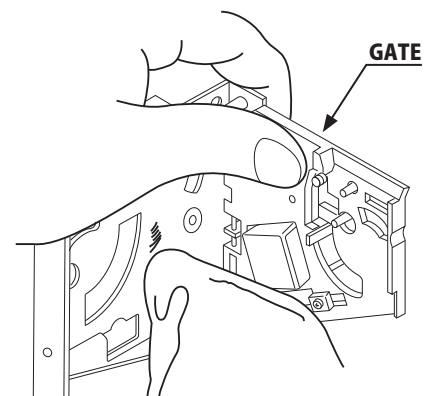

12-1 FIG 1

## CLEANING THE COIN SELECTOR (MECHANICAL).

**1** Remove and clean smears by using a soft cloth dipped in water or diluted chemical detergent and then squeezed dry.

**2** Remove the CRADLE.. When removing the retaining ring (E ring) be very careful so as not to bend the rotary shaft.

**3** Remove stain from the rotary shaft and shaft receiving portions by wiping off with a soft cloth, etc.

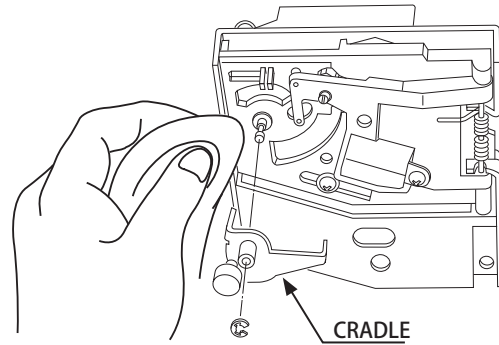

12-1 FIG 2

**4** After wiping off as per previous step, further apply a dry cloth to completely dry the Coin Selector.

### Coin Insertion Test

Once every month, when performing the Coin SW Test, simultaneously check the following:

Does the Coin Meter count satisfactorily?

Does the coin drop into the cashbox correctly?

Is the coin rejected when inserted while keeping the REJECT Button pressed down?

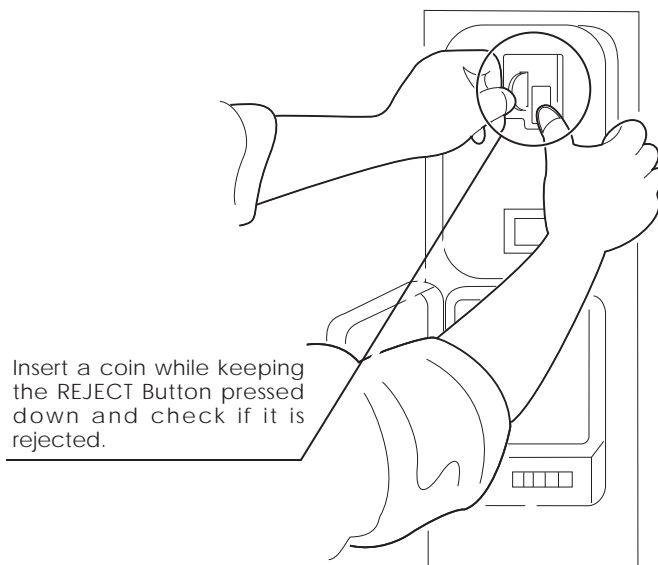

12-1 FIG 3



## CLEANING THE COIN SELECTOR (SR3) <continued>

12

COIN HANDLING

- 1 Remove and clean smears by using a damp soft cloth dipped in water. **DO NOT** use any diluted chemical detergent or cleansing agent as this will impair the workings of the component.

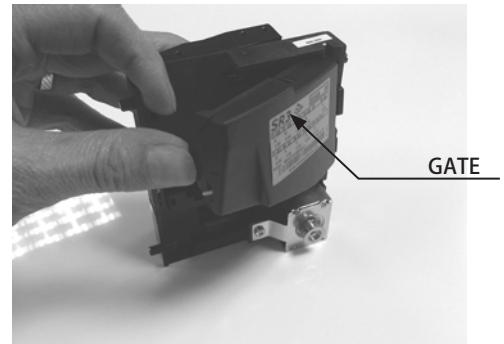

- 2 Open the reject gate to gain access to the rundown path.

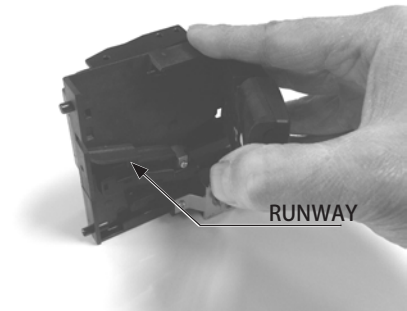

- 3 Remove the dirt and stains from the runway by wiping off with a soft damp cloth.

- 4 After wiping off as per previous step, further apply a dry cloth to completely dry the coin Selector.



## 12-2 FAULT FINDING

### Fault Finding

The following information is presented for customers' guidance in rectifying a fault but does not cover all possible causes.

All acceptors with electronic faults should be returned to an approved service centre for repair.

| SYMPTOM                                      | INVESTIGATE           | POSSIBLE CAUSE   |
|--|-----------------------|--|
| Acceptor does not work<br>(all coins reject) | Connector             | Poor Contact   |
|  |                       | Loose Wire   |
|  | Power Supply          | Not switched on  |
|  |                       | Incorrect voltage  |
|  |                       | Inadequate current   |
|  |                       | Rise time too slow   |
|  | Inhibit all inputs    | Acceptor Inhibited   |
|  | Accept gate           | Gate not free or dislocated                                |
|  | Accept channel        | Obstruction  |
|  | Reject gate           | Not fully closed   |
|  | LED on rear cover RED | EEPROM chksm error   |
|  |                       | SR Sensor fault  |
|  |                       | Credit opto fault  |
| Credit sensor blocked                        |                       |  |
| Reject lever pressed                         |                       |  |
| LED on rear cover YELLOW                     | Reinstall power       |  |
| Poor Acceptance                              | Power Supply          | Voltage less than 10v<br>(Voltage drops when coil engages) |
|  | Accept gate           | Gate jam or dislocated                                     |
|  | Connector             | Loose  |
|  | Coin rundown          | Dirty  |
|  | Bank Select           | Both banks enabled   |
| Coin stick or jam in acceptor.               | Accept channel        | Acceptor dirty or may have some damage                     |
|  | Accept gate           |  |
|  | Reject gate           |  |
| A true coin type rejects                     | Label                 | Coin not programmed  |
| No accept signal                             | Connector             | Loose or broken wire                                       |
|  | Accept channel        | Path dirty or obstructed                                   |

## 12-3 ADJUSTING THE PRICE OF PLAY (EXCEL)

### STOP IMPORTANT

- The price of play is determined by the configuration of switches located on either an EXCEL board or VTS board. The type of board used is determined by product location. Switch settings for both types of board remain the same.

This product comes equipped with a Money Controls SR3 Coin Acceptor. To adjust the price of play ALL credit settings are adjusted via the EXCEL CREDIT BOARD.

#### IMPORTANT!

The CREDIT SETTINGS within the SYSTEM TEST MODE must be set to 1 coin 1 credit to allow the CREDIT BOARD to function correctly.

The VTS BD has a built in Credit Board. This is controlled by 2 DIL Switches. These allow the operator to select the price of play, type of coin acceptor and region.

#### EXCEL Credit Board

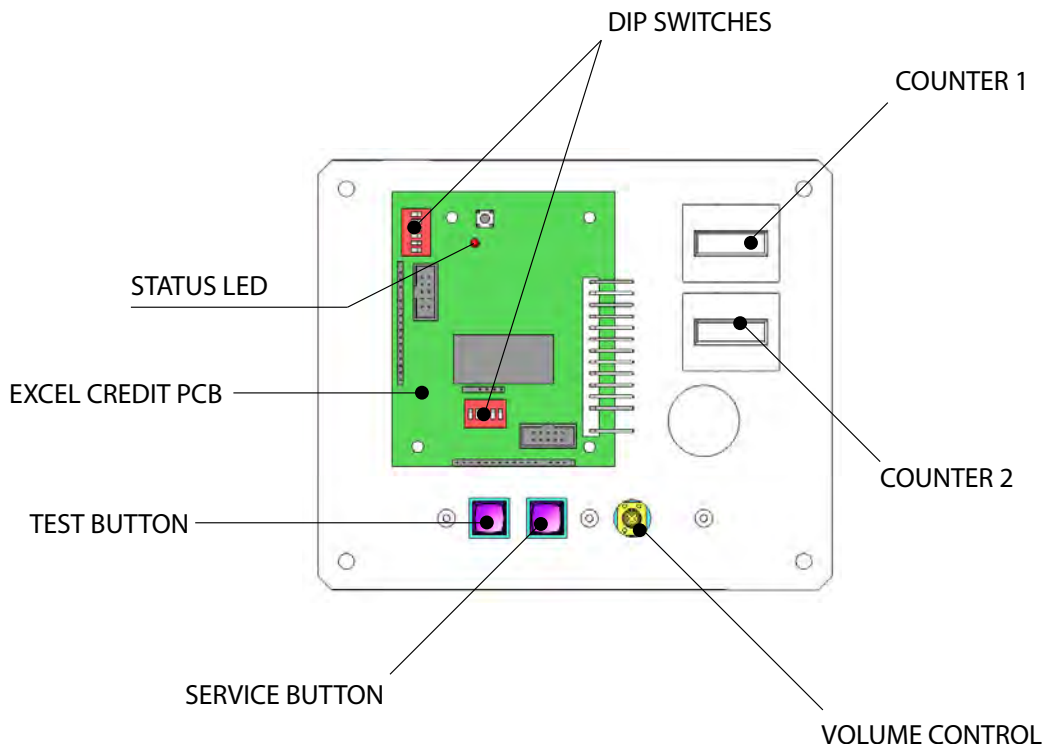

#### DIL SW3 (Regional Settings)

Adjust these switches to specify the type of Coin Acceptor used and currency.

Default = SW1&SW2 ON - NRI in parallel mode, Sterling.

#### TEST BUTTON

Provides access to the TEST MENU when pressed.

#### SERVICE BUTTON

Provides a SERVICE CREDIT when pressed

#### Status LED

Flashes when functioning.

#### CHANNEL 1

To Coin Acceptor (SR3 TYPE.)

#### DIL SW1 (credit settings)

Adjust to required price of pay.

#### VOL CONTROL

MAIN VOLUME ADJUSTMENT (FRONT SPEAKERS)

## 12-4 ADJUSTING THE PRICE OF PLAY (VTS)

This product comes equipped with a Money Controls SR3 Coin Acceptor. To adjust the price of play ALL credit setting are adjusted via the EXCEL CREDIT BOARD.

### IMPORTANT!

The CREDIT SETTINGS within the SYSTEM TEST MODE must be set to 1 coin 1 credit to allow the CREDIT BOARD to function correctly.

The VTS BD has a built in Credit Board. This is controlled by 2 DIL Switches. These allow the operator to select the price of play, type of coin acceptor and region.

### VTS Board

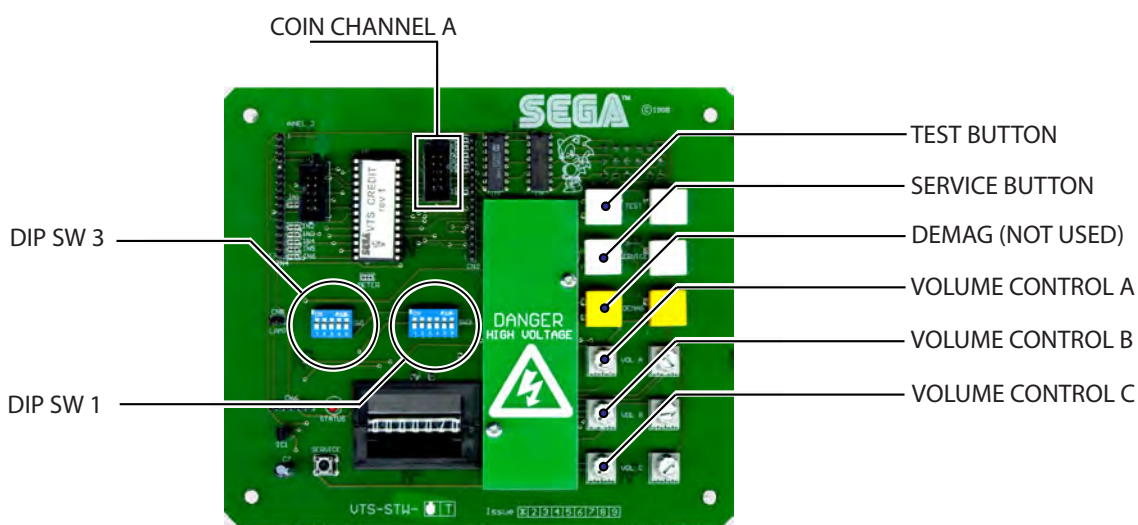

### DIL SW3 (Regional Settings)

Adjust these switches to specify the type of Coin Acceptor used and currency.

Default = SW1&SW2 ON - SR3 in parallel mode, Sterling.

|                           |  |
|---------------------------|--|
| TEST BUTTON               | Provides access to the TEST MENU when pressed. |
| SERVICE BUTTON            | Provides a SERVICE CREDIT when pressed         |
| Status LED                | Flashes when functioning.                      |
| CHANNEL A                 | To Coin Acceptor (SR3 TYPE.)                   |
| DIL SW1 (credit settings) | Adjust to required price of pay.               |
| DEMAG                     | NOT USED                                       |
| VOL CONTROL A             | MAIN VOLUME ADJUSTMENT (FRONT SPEAKERS)        |
| VOL CONTROL B             | SECONDARY VOL ADJUSTMENT (GUN SPEAKERS)        |
| VOL CONTROL C             | NOT USED                                       |

**REGIONAL AND ACCEPTOR SETTINGS (SW3)**

| Country       | Setting                     | Switch 3 Setting |     |     |     |     |     | Credit Board Mode Settings Switch 3 |           |                |           |         |           |               |           |           |        |        |        |
|---------------|-----------------------------|------------------|-----|-----|-----|-----|-----|-------------------------------------|-----------|----------------|-----------|---------|-----------|---------------|-----------|-----------|--------|--------|--------|
|               |                             | SW1              | SW2 | SW3 | SW4 | SW5 | SW6 | Coin Validator Programming          |           |                |           |         |           | C120/SR3 Only |           |           |        |        |        |
|               |                             |                  |     |     |     |     |     | COIN1                               | COIN2     | COIN3          | COIN4     | COIN5   | COIN6     | COIN7         | COIN8     | COIN9     | COIN10 | COIN11 | COIN12 |
| UK            | Coin Controls C220 Parallel | OFF              | OFF | OFF | OFF |     |     | £1                                  | 50p new   | 20p            | 10p       | -       | 50p old   | -             | -         |           |        |        |        |
| UK            | Coin Controls C220 Binary   | ON               | OFF | OFF | OFF |     |     | £1                                  | 50p new   | 20p            | 10p       | -       | 50p old   | -             | £2        |           |        |        |        |
| UK            | Coin Controls C220 Binary   | OFF              | ON  | OFF | OFF |     |     | £1                                  | 50p new   | 20p            | 10p       | -       | £2        | -             | 50p old   |           |        |        |        |
| UK            | Coin Controls C220 Binary   | ON               | ON  | OFF | OFF |     |     | £1                                  | 50p new   | 20p            | 10p       | -       | £2        | -             | 50p old   |           |        |        |        |
| UK            | Coin Controls SR3 Parallel  | ON               | ON  | OFF | OFF |     |     | £2                                  | £1        | 50p new        | 20p       | 10p     | -         | £2            | -         | 50p old   |        |        |        |
| UK            | Coin Controls SR3 Parallel  | OFF              | OFF | ON  | OFF |     |     | £2                                  | £1        | 50p new        | 20p       | 10p     | -         | -             | -         | 50p old   |        |        |        |
| UK            | Coin Controls SR3 Parallel  | ON               | OFF | ON  | OFF |     |     | £1                                  | £2        | 20p            | 10p       | 50p new | 50p old   |               |           |           |        |        |        |
| UK            | Mars MEMS 111 Parallel      | ON               | OFF | ON  | OFF |     |     | 10p                                 | 20p       | 50p            | £1        | £2      | -         |               |           |           |        |        |        |
| UK            | NRI Parallel                | OFF              | ON  | ON  | OFF |     |     | -                                   | 50BfT     | 20BfT          | 5BfT      |         |           |               |           |           |        |        |        |
| Belgium       | Parallel                    | ON               | ON  | ON  | OFF |     |     | -                                   | 50BfT     | 20BfT          | 5BfT      |         |           |               |           |           |        |        |        |
| Holland       | Parallel                    | OFF              | OFF | OFF | ON  |     |     | -                                   | 5NLG      | 2.5NLG         | 1NLG      |         |           |               |           |           |        |        |        |
| Austria       | SR3 Parallel                | ON               | OFF | OFF | ON  |     |     | 20Sch                               | 10Sch     | 5Sch           | 1Sch      |         |           |               |           |           |        |        |        |
| Spain         | Coin Controls C220 Binary   | OFF              | ON  | OFF | ON  |     |     | 500Pta                              | 200Pta    | 100Pta         | 50Pta     | 25Pta   | 200Pt old | 50Pta old     | 25Pta old |           |        |        |        |
| Spain         | SR3/NRI Parallel            | ON               | ON  | OFF | ON  |     |     | 500Pta                              | 200Pta    | 100Pta         | 50Pta     | 25Pta   | -         | 200Pta old    | 50Pta old | 25Pta old |        |        |        |
| Spain         | Coin Controls C220 Parallel | OFF              | OFF | ON  | ON  |     |     | 100Pta                              | 50Pta new | -              | 25Pta new | -       | 50Pta old | -             | 25Pta old |           |        |        |        |
| Portugal Euro | Parallel                    | ON               | OFF | ON  | ON  |     |     | 200Es                               | 100Es     | 50Es           | -         | -       | -         | -             | -         |           |        |        |        |
|               | TBA                         |                  |     |     | OFF |     |     | TBA                                 |           |                |           |         |           |               |           |           |        |        |        |
|               |                             |                  |     |     |     |     |     | TBA                                 |           |                |           |         |           |               |           |           |        |        |        |
|               | Channels                    |                  |     |     |     |     |     | ON                                  | OFF       | Direct Mode    |           |         |           |               |           |           |        |        |        |
|               |                             |                  |     |     |     |     |     | ON                                  | ON        | 2 channel Mode |           |         |           |               |           |           |        |        |        |

Note: These switch settings are under constant review and may change due to world currency updates.

Set SW 1 according to the option settings found in the relevant Price of Play Settings Table on the following pages.

Set SW 3 on the VTS /Excel board as shown in the table above corresponding to the country required.

**Please Note**  
The credit board automatically sets the validator for parallel and binary operation through an output on pin 8 of the 17 way pinstrip. For the feature to work it is necessary for the validator interconnecting cable to include at wire at this position

**12**  
**COIN HANDLING**

**STERLING PRICE OF PLAY SETTINGS (SW1)**

|    | Price | Bonus                           |                                |                                 |  |     | DIL Switch 1 |     |     |     |    |
|----|-------|---------------------------------|--------------------------------|---------------------------------|--|-----|--------------|-----|-----|-----|----|
|    |       |                                 |                                |                                 |  |     | 1            | 2   | 3   | 4   | 5  |
| 1  | 10p   | 50p = 5 plays                   | £1 = 10 plays                  | £2 = 20 plays                   |  | OFF | OFF          | OFF | OFF | OFF |    |
| 2  | 10p   | 50p = 6 plays @ 8.33p per play  | £1 = 12 plays @ 8.33p per play | £2 = 24 plays @ 8.33p per play  |  | ON  | OFF          | OFF | OFF | OFF |    |
| 3  | 20p   | 50p = 2.5 plays                 | £1 = 5 plays                   | £2 = 10 plays                   |  | OFF | ON           | OFF | OFF | OFF |    |
| 4  | 20p   | 50p = 3 plays @ 16.66p per play | £1 = 6 plays @ 16.66p per play | £2 = 12 plays @ 16.66p per play |  | ON  | ON           | OFF | OFF | OFF |    |
| 5  | 30p   | 50p = 1.66 plays                | £1 = 3.33 plays                | £2 = 6.66 plays                 |  | OFF | OFF          | ON  | OFF | OFF |    |
| 6  | 30p   | 50p = 1.66 plays                | £1 = 4 plays @ 25p per play    | £2 = 8 plays @ 25p per play     |  | ON  | OFF          | ON  | OFF | OFF |    |
| 7  | 30p   | 50p = 2 plays @ 25p per play    | £1 = 4 plays @ 25p per play    | £2 = 8 plays @ 25p per play     |  | OFF | ON           | ON  | OFF | OFF |    |
| 8  | 30p   | 50p = 2 plays @ 25p per play    | £1 = 3 plays @ 33.33p per play | £2 = 6 plays @ 33.33p per play  |  | ON  | ON           | ON  | OFF | OFF |    |
| 9  | 40p   | 50p = 1.25 plays                | £1 = 2.5 plays                 | £2 = 5 plays                    |  | OFF | OFF          | OFF | ON  | OFF |    |
| 10 | 40p   | 50p = 1.25 plays                | £1 = 3 plays @ 33.3p per play  | £2 = 6 plays @ 33.3p per play   |  | ON  | OFF          | OFF | ON  | OFF |    |
| 11 | 50p   | 50p = 1 play                    | £1 = 2 plays                   | £2 = 4 plays                    |  | OFF | ON           | OFF | ON  | OFF |    |
| 12 | 50p   | 50p = 1 play                    | £1 = 3 plays @ 33.3p per play  | £2 = 6 plays @ 33.3p per play   |  | ON  | ON           | OFF | ON  | OFF |    |
| 13 | 50p   | 50p = 1 play                    | £1 = 2 plays                   | £2 = 5 plays @ 40p per play     |  | OFF | OFF          | ON  | ON  | OFF |    |
| 14 | 60p   | 50p = 0.83 play                 | £1 = 1.66 plays                | £2 = 3.33 plays                 |  | ON  | OFF          | ON  | ON  | OFF |    |
| 15 | 60p   | 50p = 0.83 play                 | £1 = 2 plays @ 50p per play    | £2 = 4 plays @ 50p per play     |  | OFF | ON           | ON  | ON  | OFF |    |
| 16 | 80p   | 50p = 0.62 play                 | £1 = 1.25 plays                | £2 = 2.5 plays                  |  | ON  | ON           | ON  | ON  | OFF |    |
| 17 | 80p   | £1 = 1.25 plays                 | £1.50 = 2 plays @ 75p per play | £2 = 2.5 plays                  |  | OFF | OFF          | OFF | OFF | ON  |    |
| 18 | £1    | 2x50p = 1 play                  | £1 = 1 play                    | £2 = 2 plays                    |  | ON  | OFF          | OFF | OFF | ON  |    |
| 19 | £1    | 2x50p = 1 play                  | £1 = 1 play                    | £2 = 3 plays @ 66.6p per play   |  | OFF | ON           | OFF | OFF | ON  |    |
| 20 | £1    | 2x50p = 1 play                  | £2 = 2 plays                   | £4 = 5 plays @ 80p per play     |  | ON  | ON           | OFF | OFF | ON  |    |
| 21 | £1.50 | 3x50p = 1 play                  | £1 = 0.66 plays                | £3 = 2 plays                    |  | OFF | OFF          | ON  | OFF | ON  |    |
| 22 | £1.50 | 3x 50p = 1 play                 | £1 = 0.66 plays                | £2 = 2 plays @ £1 per play      |  | ON  | OFF          | ON  | OFF | ON  |    |
| 23 | £2    | 4x 50p = 1 play                 | £1 = 0.5 play                  | £2 = 1 play                     |  | OFF | ON           | ON  | OFF | ON  |    |
| 24 | £2    | 4x 50p = 1 play                 | £1 = 0.5 play                  | £5 = 3 plays @ £1.66 per play   |  | ON  | ON           | ON  | OFF | ON  |    |
| 25 | £3    | 6x50p = 1 play                  | £1.50 = 0.5 play               | £3 = 1 play                     |  | OFF | OFF          | OFF | ON  | ON  |    |
| 26 | £3    | 6x50p = 1 play                  | £1.50 = 0.5 play               | £5 = 2 plays @ £2.50 per play   |  | ON  | OFF          | OFF | ON  | ON  |    |
| 27 | £5    | £1 = 0.2 play                   | £5 = 1 play                    | £10 = 2 plays                   |  | OFF | ON           | OFF | ON  | ON  |    |
| 28 | £5    | £1 = 0.2 play                   | £5 = 1 play                    | £10 = 3 plays @ £3.33p per play |  | ON  | ON           | OFF | ON  | ON  |    |
| 29 | £7.50 | £5 = 0.66 play                  | £10 = 1.33 plays               | £15 = 2 plays                   |  | OFF | OFF          | ON  | ON  | ON  |    |
| 30 | £7.50 | £5 = 0.66 play                  | £10 = 1.33 plays               | £10 = 2 plays @ £5 per play     |  | ON  | OFF          | ON  | ON  | ON  |    |
| 31 | £10   | £10 = 1 play                    | £20 = 2 play                   | £30 = 3 play                    |  | OFF | ON           | ON  | ON  | ON  |    |
| 32 |       | Free Play                       |                                |                                 |  |     | ON           | ON  | ON  | ON  | ON |

**EURO PRICE OF PLAY SETTINGS (SW1)**

|    | Price | Bonus                           |                                |                                 |  |     | DIL Switch 1 |     |     |     |   |
|----|-------|---------------------------------|--------------------------------|---------------------------------|--|-----|--------------|-----|-----|-----|---|
|    |       |                                 |                                |                                 |  |     | 1            | 2   | 3   | 4   | 5 |
| 1  | 10¢   | 50¢ = 5 plays                   | €1 = 10 plays                  | €2 = 20 plays                   |  | OFF | OFF          | OFF | OFF | OFF |   |
| 2  | 10¢   | 50¢ = 6 plays @ 8.33p per play  | €1 = 12 plays @ 8.33¢ per play | €2 = 24 plays @ 8.33¢ per play  |  | ON  | OFF          | OFF | OFF | OFF |   |
| 3  | 20¢   | 50¢ = 2.5 plays                 | €1 = 5 plays                   | €2 = 10 plays                   |  | OFF | ON           | OFF | OFF | OFF |   |
| 4  | 20¢   | 50¢ = 3 plays @ 16.66¢ per play | €1 = 6 plays @ 16.66¢ per play | €2 = 12 plays @ 16.66¢ per play |  | ON  | ON           | OFF | OFF | OFF |   |
| 5  | 30¢   | 50¢ = 1.66 plays                | €1 = 3.33 plays                | €2 = 6.66 plays                 |  | OFF | OFF          | ON  | OFF | OFF |   |
| 6  | 30¢   | 50¢ = 1.66 plays                | €1 = 4 plays @ 25¢ per play    | €2 = 8 plays @ 25¢ per play     |  | ON  | OFF          | ON  | OFF | OFF |   |
| 7  | 30¢   | 50¢ = 2 plays @ 25¢ per play    | €1 = 4 plays @ 25¢ per play    | €2 = 8 plays @ 25¢ per play     |  | OFF | ON           | ON  | OFF | OFF |   |
| 8  | 30¢   | 50¢ = 2 plays @ 25¢ per play    | €1 = 3 plays @ 33.33¢ per play | €2 = 6 plays @ 33.33¢ per play  |  | ON  | ON           | ON  | OFF | OFF |   |
| 9  | 40¢   | 50¢ = 1.25 plays                | €1 = 2.5 plays                 | €2 = 5 plays                    |  | OFF | OFF          | OFF | ON  | OFF |   |
| 10 | 40¢   | 50¢ = 1.25 plays                | €1 = 3 plays @ 33.33¢ per play | €2 = 6 plays @ 33.33¢ per play  |  | ON  | OFF          | OFF | ON  | OFF |   |
| 11 | 50¢   | 50¢ = 1 play                    | €1 = 2 plays                   | €2 = 4 plays                    |  | OFF | ON           | OFF | ON  | OFF |   |
| 12 | 50¢   | 50¢ = 1 play                    | €1 = 3 plays @ 33.33¢ per play | €2 = 6 plays @ 33.33¢ per play  |  | ON  | ON           | OFF | ON  | OFF |   |
| 13 | 50¢   | 50¢ = 1 play                    | €1 = 2 plays                   | €2 = 5 plays @ 40¢ per play     |  | OFF | OFF          | ON  | ON  | OFF |   |
| 14 | 60¢   | 50¢ = 0.83 play                 | €1 = 1.66 plays                | €2 = 3.33 plays                 |  | ON  | OFF          | ON  | ON  | OFF |   |
| 15 | 60¢   | 50¢ = 0.83 play                 | €1 = 2 plays @ 50¢ per play    | €2 = 4 plays @ 50¢ per play     |  | OFF | ON           | ON  | ON  | OFF |   |
| 16 | 80¢   | 50¢ = 0.62 play                 | €1 = 1.25 plays                | €2 = 2.5 plays                  |  | ON  | ON           | ON  | ON  | OFF |   |
| 17 | 80¢   | €1 = 1.25 plays                 | €1.50 = 2 plays @ 75¢ per play | €2 = 2.5 plays                  |  | OFF | OFF          | OFF | OFF | ON  |   |
| 18 | €1    | 2x50¢ = 1 play                  | €1 = 1 play                    | €2 = 2 plays                    |  | ON  | OFF          | OFF | OFF | ON  |   |
| 19 | €1    | 2x50¢ = 1 play                  | €1 = 1 play                    | €2 = 3 plays @ 66.6¢ per play   |  | OFF | ON           | OFF | OFF | ON  |   |
| 20 | €1    | 2x50¢ = 1 play                  | €2 = 2 plays                   | €4 = 5 plays @ 80¢ per play     |  | ON  | ON           | OFF | OFF | ON  |   |
| 21 | €1.50 | 3x50¢ = 1 play                  | €1 = 0.66 plays                | €3 = 2 plays                    |  | OFF | OFF          | ON  | OFF | ON  |   |
| 22 | €1.50 | 3x 50¢ = 1 play                 | €1 = 0.66 plays                | €2 = 2 plays @ €1 per play      |  | ON  | OFF          | ON  | OFF | ON  |   |
| 23 | €2    | 4x 50¢ = 1 play                 | €1 = 0.5 play                  | €2 = 1 play                     |  | OFF | ON           | ON  | OFF | ON  |   |
| 24 | €2    | 4x 50¢ = 1 play                 | €1 = 0.5 play                  | €5 = 3 plays @ €1.66 per play   |  | ON  | ON           | ON  | OFF | ON  |   |
| 25 | €3    | 6x50¢ = 1 play                  | €1.50 = 0.5 play               | €3 = 1 play                     |  | OFF | OFF          | OFF | ON  | ON  |   |
| 26 | €3    | 6x50¢ = 1 play                  | €1.50 = 0.5 play               | €5 = 2 plays @ €2.50 per play   |  | ON  | OFF          | OFF | ON  | ON  |   |
| 27 | €5    | €1 = 0.2 play                   | €5 = 1 play                    | €10 = 2 plays                   |  | OFF | ON           | OFF | ON  | ON  |   |
| 28 | €5    | €1 = 0.2 play                   | €5 = 1 play                    | €10 = 3 plays @ 3.33¢ per play  |  | ON  | ON           | OFF | ON  | ON  |   |
| 29 | €7.50 | €5 = 0.66 play                  | €10 = 1.33 plays               | €15 = 2 plays                   |  | OFF | OFF          | ON  | ON  | ON  |   |
| 30 | €7.50 | €5 = 0.66 play                  | €10 = 1.33 plays               | €10 = 2 plays @ €5 per play     |  | ON  | OFF          | ON  | ON  | ON  |   |
| 31 | €10   | €10 = 1 play                    | €20 = 2 play                   | €30 = 3 play                    |  | OFF | ON           | ON  | ON  | ON  |   |
| 32 |       |                                 | Free Play                      |                                 |  | ON  | ON           | ON  | ON  | ON  |   |

## 13 LAMPS AND LIGHTING

### ⚠ WARNING

- When working with the product, be sure to turn the power off. Working with the power on may cause an electric shock or short circuit.
- You may get burned by a hot fluorescent lamp or other lamps. Pay full attention to the lamps when performing the work.
- Be sure to use lamps of the designated rating. Using lamps of undesignated rating can cause a fire or malfunctioning.
- There is the danger of short circuits or smoke generation due to deterioration of insulation in lighting fixtures resulting from age deterioration. Check for anomalies such as the following: Does it smell like something is burning? Is there socket discoloration? Are any lamps being replaced frequently? Do lamps not go on properly?

### ⚠ CAUTION

The Coin Door Lamp utilises a 12v 1.2w Wedge Bulb. It is important that you replace this bulb or any other bulb of that of the same voltage and rating. Failing to observe this caution may result in PCB failure or possible fire hazard.

### 13-1 COIN DOOR LAMP

Step 1. Open the Coin Door and locate the Lamp Housing directly behind the Coin Insert Bezel. Lamp Housing

Step 2. Hold the Lamp Housing firmly between your index finger and thumb and gently pull upwards. Do Not try to remove the Lamp Housing whilst holding the bulb as the bulb may break causing injury.

Step 3. Once the Lamp Housing has been removed, carefully hold the bulb between your fingers and pull the Lamp Housing away.

Do not twist either bulb or Lamp Housing whilst removing the bulb as this may cause damage to both bulb and or Housing.

Type: Wedge Bulb - 12v, 1.2w

Step 4. Simply push-fit a replacement bulb of the same type and follow these steps in reverse to refit.





## 13-2 FLUORESCENT TUBES - BILLBOARD

### **⚠ WARNING**

**THIS WORK ON TOP OF THE CABINET, SHOULD NOT BE UNDERTAKEN WITHOUT THE USE OF A SUITABLE STEP OR FOOTSTOOL.**

**1** TURN THE POWER OFF.

**2** Remove the Billboard plate by following the BILLBOARD INSTALLATION GUIDE in reverse on Chapter 2 of this manual.

Self Adhesive LED strip Pt No: DB6001UK (8)  
Inc: LED strip/Adhesive Backing/Harness

LED REDEYE Pt No LT1055 (1)

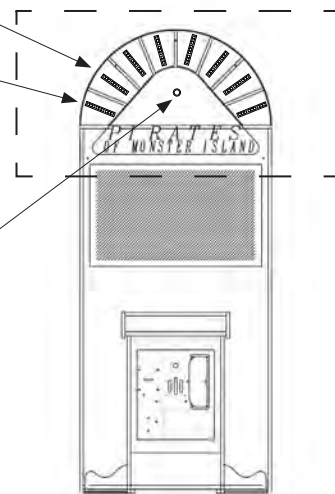

**3** Disconnect the particular LED harness and carefully peel off the LED strip from the back surface of the Billboard.

**4** Remove the protective backing from the replacement LED strip and carefully adhere it into the same location as the previous LED. Route the harness accordingly so that no shadowing will be noticed once the Billboard is in place.

**5** Reconnect the harness and test before re applying the Billboard Plate.

## LED (PIRATES EYE)

**1** TURN THE POWER OFF.

**2** Remove the Billboard plate by following the BILLBOARD INSTALLATION GUIDE in reverse on Chapter 2 of this manual. The LED PIRATES EYE is mounted to the rear of the BILLBOARD PLATE. Disconnect LED PIRATES EYE LED harness before removal.

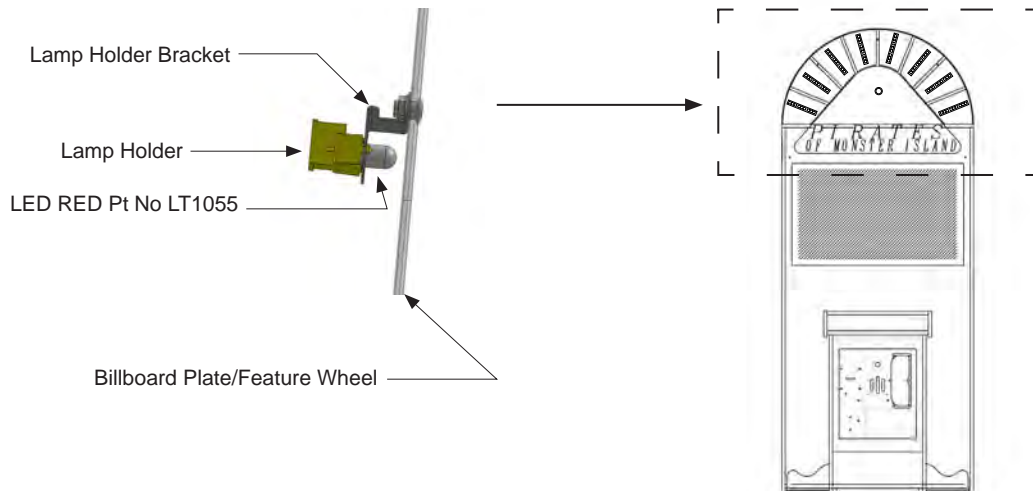

**3** With the BILLBOARD PLATE removed, pinch the sides of the Lamp Holder to release it from the Lamp Holder Bracket.

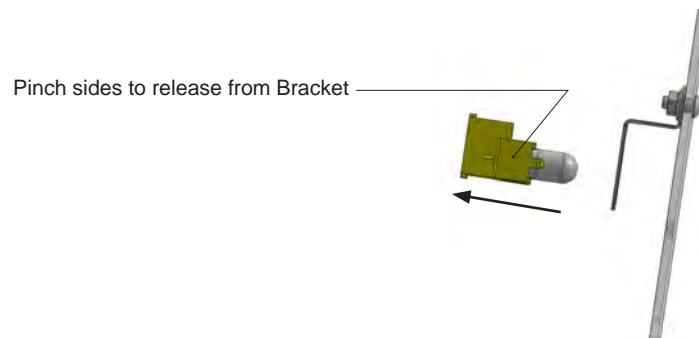

**4** Once the Lamp Holder is free from the Bracket remove the LED by carefully pulling it directly out of the Holder. Replace LED and reassemble in reverse order. *Please Note: Do not twist LED as this will damage the LED and the HOLDER.*

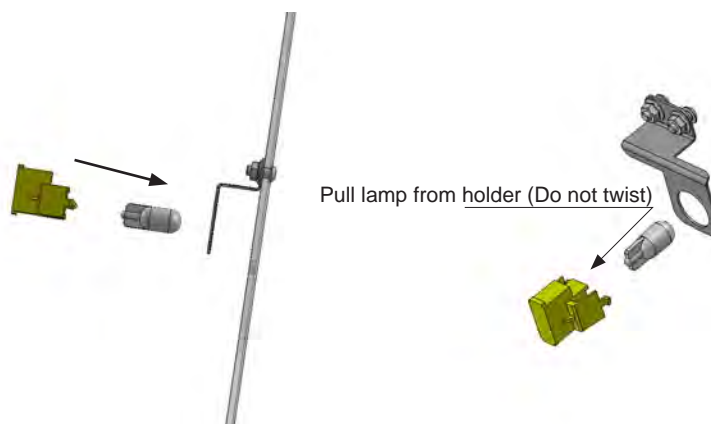

BASE (WAVE LED'S)

**⚠ WARNING**

**THIS WORK MAY REQUIRE LIFTING THE CABINET OR PLACING THE CABINET ON ITS SIDE IN ORDER TO GAIN ACCESS TO THE LED STRIP BRACKET FIXINGS.**

**WHEN LIFTING THE CABINET, ALWAYS DO SO BY USING SUITABLE LIFTING EQUIPMENT. NEVER ATEMPT TO BALANCE THE CABINET AGAINST ANOTHER SURFACE IN ATEMPT TO GAIN ACCES TO THE FIXINGS ON THE UNDERSIDE OF THE CABINET.**

**IF LAYING THE CABINET ON ITS SIDE BE SURE TO PROVIDE SOME CUSHIONING TO PROTECT THE CABINET. ALWAYS GET HELP AND NEVER ATEMPT WORK SINGLE HANDEDLY.**

**1** TURN THE POWER OFF.

**2** The WAVE LED strips are located inside the Edge Brackets which help to secure the WAVE artwork inplace.

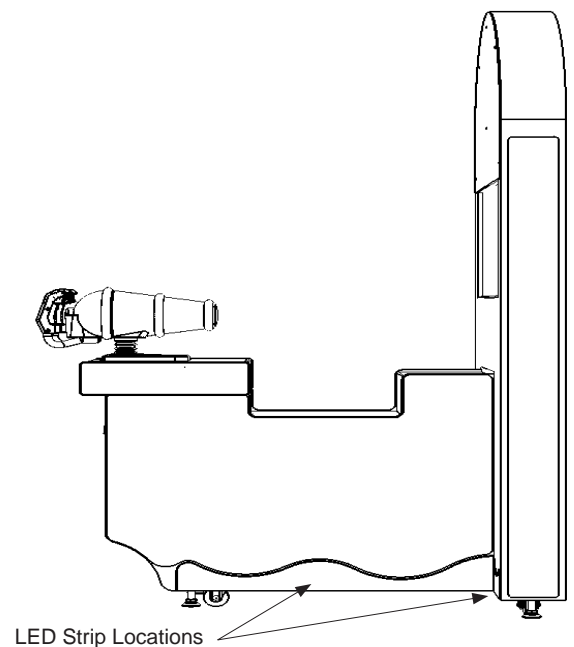

**3** Locate and unscrew the fixings (5), remove the bracket taking care not to damage the harness which is connected to the cabinet

**4** The WAVE LED strips are self adhesive flexi strip Pt No: PG-60020-750BUK

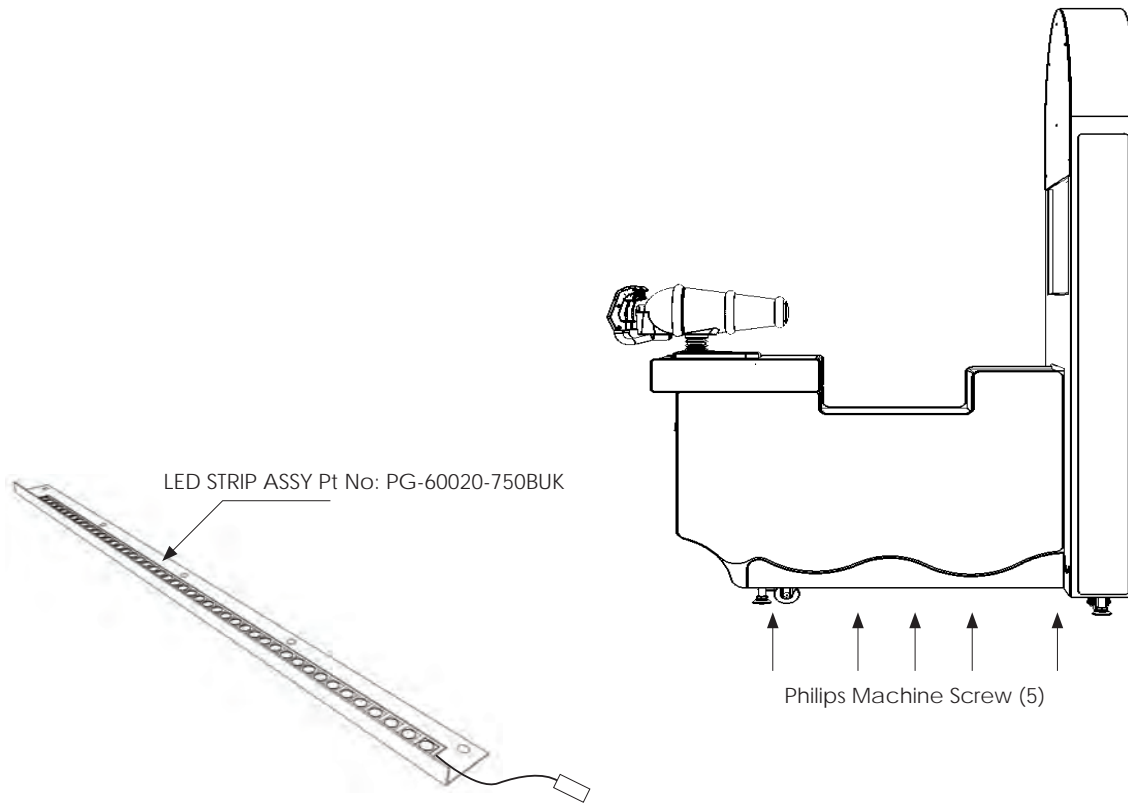

**5** Carefully peel away the old LED Strip and adhere the replacement in an identical location. If the LED strip is not placed in the same location the “WAVE” effect may be impaired.

**6** Refit the LED bracket along with the LED strip in reverse order.

**7** Please use the same instruction and caution in removing the shorter LED strips which are placed at right angles to the one mentioned above.

Part Number for LONG LED STRIP (750mm) - PG-60020-750BUK  
SHORT LED STRIP (150mm) - PG-60020-150BUK

## 14 PERIODIC INSPECTION

The items listed below require periodic check and maintenance to retain the performance of this machine and to ensure safe business operation.

When handling the controller, the player will be in direct contact with it. In order to always allow the player to enjoy the game, be sure to clean it regularly. Also, it is advisable to provide wet tissue, etc. available for player use.

### WARNING

- Every 6 months check to see if power cords are damaged, the plug is securely inserted, dust is accumulated between the socket outlet and the power plug, etc. Using the product with accumulated dust in the interior may cause fire or electric shock.
- Never use a water jet, etc. to clean the inside and outside of the cabinet. If wetness occurs for any reason, do not use the product until it has completely dried.
- Once a year, request the office shown on this manual or the dealer from whom the product was originally purchased to perform the internal cleaning. Using the product with accumulated dust in the interior may cause fire or other accidents.

Note that you are liable for the cost of cleaning the interior parts.

- There is the danger of accidents involving electrical shorts circuits or fire caused by factors such as the deterioration of insulation in electrical and electronic equipment over time. Check that there are no abnormalities such as odors from burning.

14 TABLE 01 PERIODIC INSPECTION TABLE

| ITEMS                       | DESCRIPTION                          | PERIOD                 |
|-----------------------------|--------------------------------------|------------------------|
| CABINET                     | Confirm that adjusters contact floor | Daily                  |
| CONTROL PANEL<br>CONTROLLER | H and V POT inspection               | Monthly                |
|                             | Gear alignment inspection            | Every 3 months         |
|                             | Greasing                             | Every 3 months         |
| MONITOR                     | Screen cleaning                      | Weekly                 |
|                             | Confirm settings                     | Monthly or when moving |
| COIN CHUTE DOOR             | Coin switch inspection               | Monthly                |
|                             | Coin insertion test                  | Monthly                |
|                             | Selector cleaning                    | Every 3 months         |
| GAME BOARD                  | Confirm settings                     | Monthly                |
| POWER CABLES                | Inspection, Cleaning                 | 6 months               |
| INTERIOR                    | Cleaning                             | Yearly                 |
| CABINET SURFACES            | Cleaning                             | As appropriate         |
| LAMPS/LEDS                  | Check Operation                      | As appropriate         |

### Cleaning the Cabinet Surfaces

When the cabinet surfaces are badly soiled, remove stains with a soft cloth dipped in water or diluted (with water) chemical detergent and squeezed dry. To avoid damaging surface finish, do not use such solvents as thinner, benzine, etc. other than ethyl alcohol, or abrasives, bleaching agent and chemical dustcloth.

Some general-purpose household, kitchen and furniture cleaning products may contain strong solvents that degrade plastic components, coatings, and print. Before using any cleaning product, read the product's cautionary notes carefully and test the product first on a small area that is not highly visible.

### Controller (Greasing to H and V Potentiometers)

Apply a suitable lubricant to the grearing of the potentiometers. Please visit Chapter 10 of this manual for complete disassemble and assemble instructions.

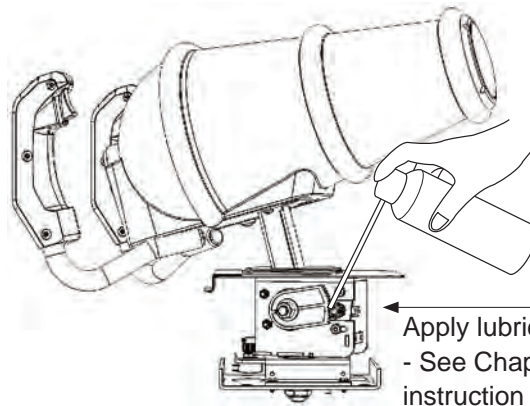

Apply lubricant to areas of contact  
- See Chapter 10 for detailed instruction

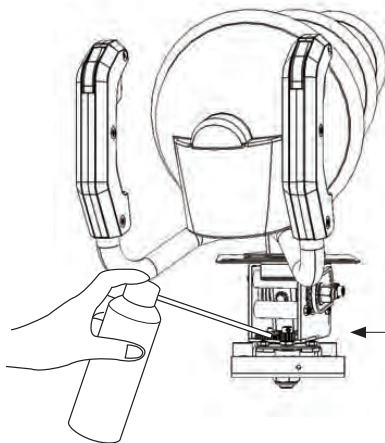

Apply lubricant to areas of contact  
- See Chapter 10 for detailed instruction

# 15 TROUBLESHOOTING

## 15-1 TROUBLESHOOTING (WHEN NO ERROR MESSAGE IS SHOWN)

**15** TROUBLESHOOTING

### WARNING

- In order to prevent electric shock and short circuit, be sure to turn power off before performing work.
- Be careful so as not to damage wirings. Damaged wiring can cause electric shock or short circuit.
- After removing the cause of the functioning of the Circuit Protector, reinstate the Circuit Protector. Depending on the cause of the functioning, using the Circuit Protector as is without removing the cause can cause generation of heat and fire hazard.
- In the event that a problem cannot be resolved by employing the procedures listed in this Manual, be sure to request service from the office shown on this Manual or the dealer from whom the product was originally purchased. Attempts to employ procedures other than those specified in this Manual can cause electrical shock, shorting, or fire.
- In the event of a problem that is not described here, be sure to contact the office shown on this Manual or the dealer from whom the product was originally purchased. Careless attempts at repair can result in electrical shock, shorting, or fire.

If a problem occurs, first check to make sure that the wiring connectors are properly connected.

**15 TABLE 01**

| PROBLEM  | CAUSE  | COUNTERMEASURES   |
|--|--|---|
| When the main SW is turned ON, the machine is not activated. | The power is not ON.   | Firmly insert the plug into the outlet.                                     |
|  | Incorrect power source/voltage.  | Make sure that the power supply/voltage are correct.                        |
|  | The Fuse on the AC Unit has blown due to momentary over current.       | After eliminating the cause of overload, replace the specified rating fuse. |
|  | The fuse of the connect board has blown due to momentary over current. | After eliminating the cause of overload, replace the specified rating fuse. |

|  |   |   |
|--|---|---|
| Sound is not emitted.  | Sound volume adjustment is not correct  | Adjust the Switch Unit's sound adjustment volume.   |
|  | Faulty connections for various connectors   | Check the connections for the game board, amp, speakers and Volume connectors   |
|  | Malfunctioning BD, amp and speaker  | Perform Sound Test.   |
| Sounds are emitted and the lamps are lit, but the screen is black. | Faulty connections for the visual signal connector or the monitor power connector | Check the connections for the monitor and game board connectors.  |
|  | Faulty LCD Display  | See Chapter 11  |
| Colors on the monitor screen are strange.                          | Faulty connection for the visual signal connector.                                | Check the visual signal connector connection and make sure it is secured properly.  |
|  | Screen adjustment is not appropriate.   | Make adjustment appropriately.  |
| The on-screen image sways and/or shrinks.                          | The power source and voltage are no correct.                                      | Make sure that the power supply and voltage are correct.  |
| Does not accept input from any switch or volume.                   | Faulty connector connections.   | Check the connection for the I/O Board and Cabinet connector.   |
|  |   | Check the power for the I/O Board.  |
| Incorrect controller alignment.                                    | Deviation of the volume value.  | Adjust the POT value in the Test Mode.  |
|  | POT gear engagement fault.  | Adjust the engagement of the gear.  |
|  | Volume malfunctioning.  | Replace the volume.   |
|  | Detached wires.   | Check for faulty wire connections around moving parts.<br>When replacing wires, secure them so that they do not touch any moving parts. |

**Replacing Fuses**

** WARNING**

- In case fuse replacements other than those stated in this manual are necessary, contact where you purchased the product from for inquiries regarding this matter.
- In order to prevent an electric shock, be sure to turn power off and unplug from the socket outlet before performing work by touching the internal parts of the product.
- Be careful so as not to damage wirings. Damaged wiring can cause electric shock and short circuit accidents.
- Be sure to use fuses meeting specified rating. Using fuses exceeding the specified rating can cause fire and electric shock accidents.
- After eliminating the cause of the blowing of fuse, replace the fuse. Depending on the cause of fuse blowing, continued use with the fuse as is blown can cause generation of heat and fire hazard.

**FUSE LOCATIONS - IEC INLET (1x 5A 20mm Ceramic Fuse, Plus 1x Spare)  
DIST PCB (2x 6.3A 20mm Ceramic Fuse).**



## 16 GAME BOARD

16

GAME BOARD

### WARNING

- When working with the product, be sure to turn the power off. Working with the power on may cause an electric shock or short circuit.
- Be careful not to damage the wires. Damaged wires may cause an electric shock, short circuit or present a risk of fire.
- Do not use this product with connectors other than those that were connected and used with the game board at the time of shipping. Do not carelessly connect wires to connectors that were not used at the time of shipping, as this may cause overheating, smoke or fire damage.

### CAUTION

In this product, setting changes are made during the test mode. The game board need not be operated. Use the game board, etc. as is with the same setting made at the time of shipment so as not to cause electrical damage or malfunction.

### STOP IMPORTANT

Static electricity from your body may damage some electronics devices on the IC board. Before handling the IC board, touch a grounded metallic surface so that the static electricity can be discharged.

## 16-1 GAME BOARD - LOCATION & REMOVAL

### WARNING

- When returning the game board after making repairs or replacements, make sure that there are no errors in the connection of connectors. Erroneous connections can lead to electrical shock, short circuits or fires.
- When connecting a connector, check the direction carefully. Connectors must be connected in only one direction. If indiscriminate loads are applied in making connections, the connector or its terminal fixtures could be damaged, resulting in electrical shock, short circuits or fires.

The machine is fitted with Game Board Unit and several other Ancillary Boards which are fitted inside the Display Cabinet. Each machine contains its own CPU. Only qualified Personnel should attempt to Service these Units and before gaining access to the machine, it should be isolated from the mains supply

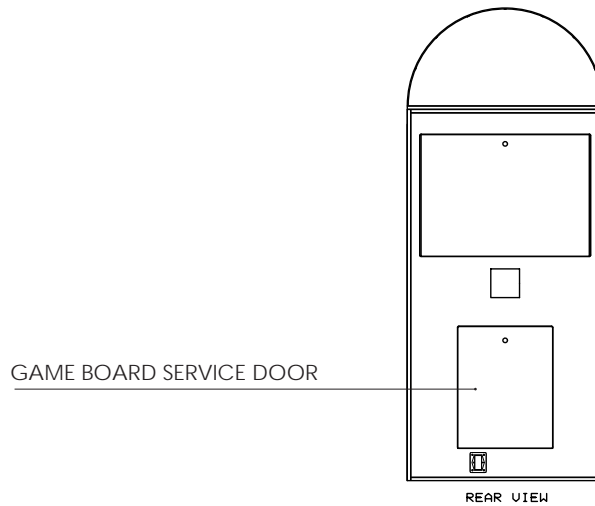

There is only one access point to the GAME BD which is through the GAME BD SERVICE DOOR located at the rear of the cabinet. Unlock the GAME BD SERVICE DOOR, the GAME BD is located on the inside left hand wall of the cabinet.

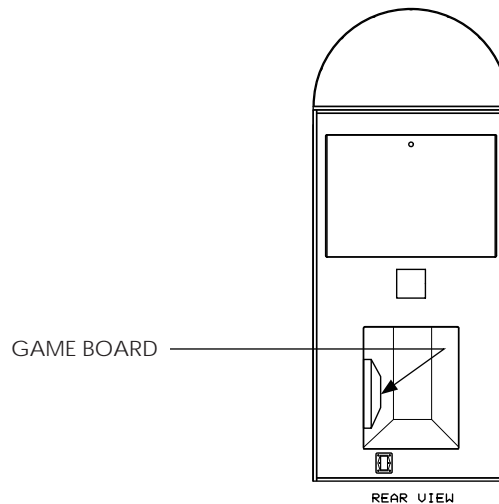

The GAME BD is mounted on a wooden Base. To remove the GAME BD, disconnect ALL connections to the GAME BD, unscrew the single fixing which secures the wooden base to the cabinet and carefully slide out the ASSY GAME BD from within the cabinet.

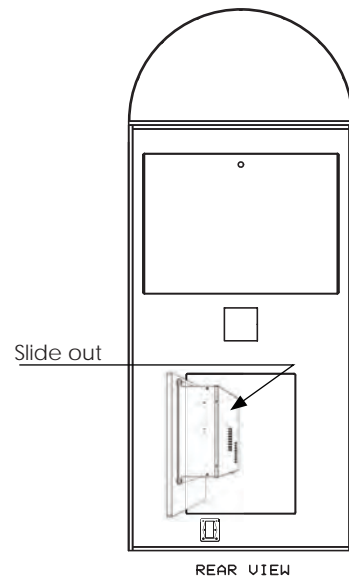
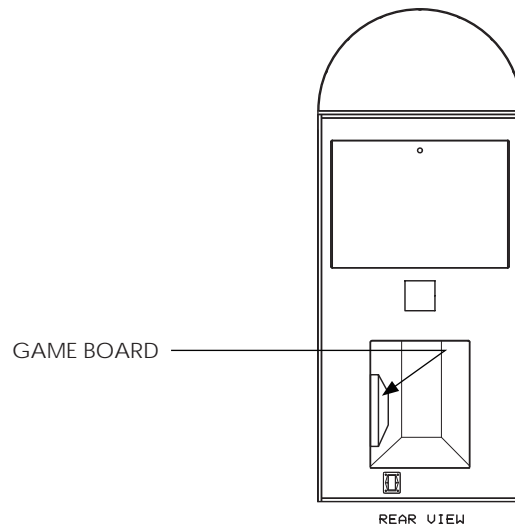

**CONNECTIONS**

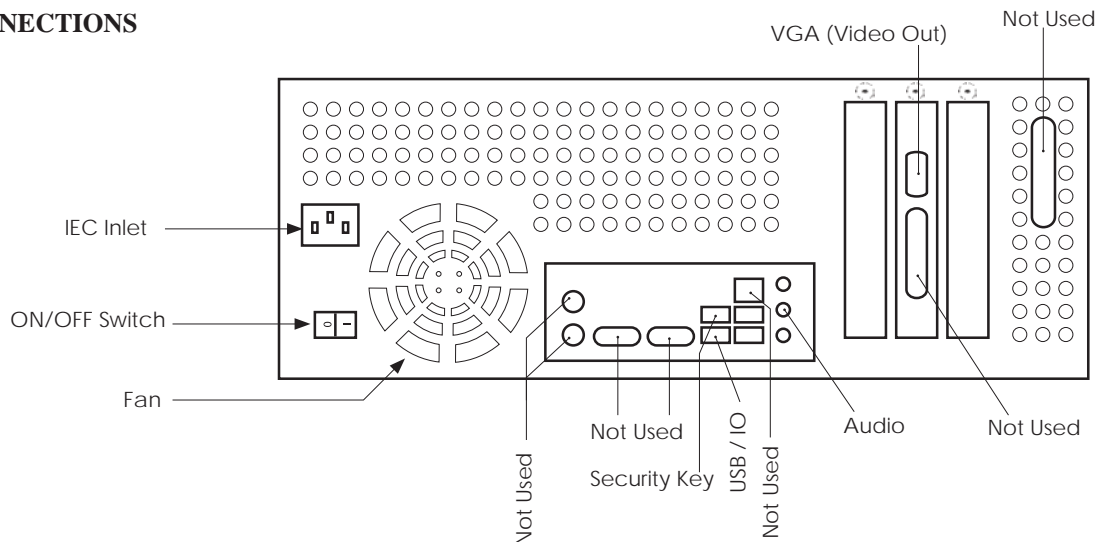

## 17 RF 8 KEY LED RGB CONTROLLER

RF 8 key LED RGB Controller



### Control method

Adopt film button control and RF control, each film button function as follows, remarked in bracket is RF button's:

ON/OFF: In any state, you could turn on or turn off the output of controller;

PAUSE: when you want to see the static effect of led, you may press this button to pause.

S+: The speed changing progression will add one when you press the button every time, there are 100 steps ;

S-: The speed changing progression will subtract one when you press the button every time.

B+: Adjusting brightness button, the brightness progression will add one when you press the button every time, there are 256 steps;

B-: The brightness progression will subtract one when you press the button every time;

M+: Pattern function key, up direction, there are 25 programs in all.

M-: down direction.

Style changing table as below:

| Items | Patterns                     | Remarks   |
|-------|------------------------------|---|
| 1     | Static red                   | Brightness is adjustable, Speed is unadjustable |
| 2     | Static green                 |   |
| 3     | Static blue                  |   |
| 4     | Static yellow                |   |
| 5     | Static purple                |   |
| 6     | Static cyan                  |   |
| 7     | Static white                 |   |
| 8     | Three-color jumpy changing   | Speed and Brightness are adjustable             |
| 9     | Seven-color jumpy changing   |   |
| 10    | Three-color gradual changing | Brightness is unadjustable, Speed is adjustable |
| 11    | Seven-color gradual changing |   |
| 12    | Three-color flowing          | Speed and Brightness are adjustable             |
| 13    | Red stroboflash              |   |
| 14    | Green stroboflash            |   |
| 15    | Blue stroboflash             |   |
| 16    | Yellow stroboflash           |   |
| 17    | Purple stroboflash           |   |
| 18    | Cyan stroboflash             |   |
| 19    | White stroboflash            |   |
| 20    | R/B crossfade                | Brightness is unadjustable, Speed is adjustable |
| 21    | B/G crossfade                |   |
| 22    | G/R crossfade                |   |
| 23    | All fade out&fade in         |   |
| 24    | Random stroboflash           | Speed and Brightness are adjustable             |
| 25    | Automation                   | 1~24  |

# 18 DESIGN-RELATED PARTS

For the warning display stickers, refer to Section 1.

18

DESIGN - RELATED PARTS

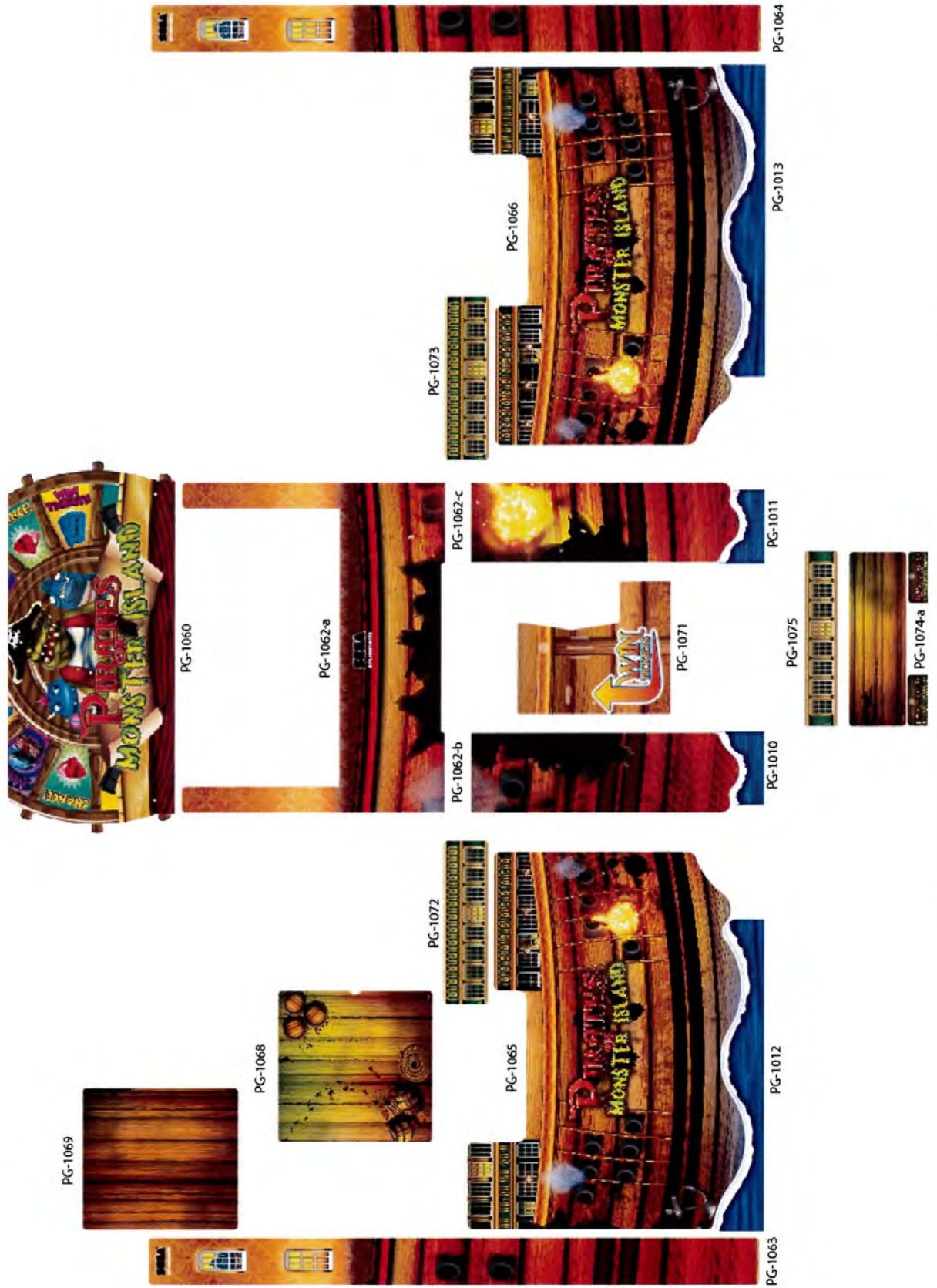

# 19 PARTS LIST

## ① ASSY POMI MAIN CABI (PG-1000UK)

(D-1/2)

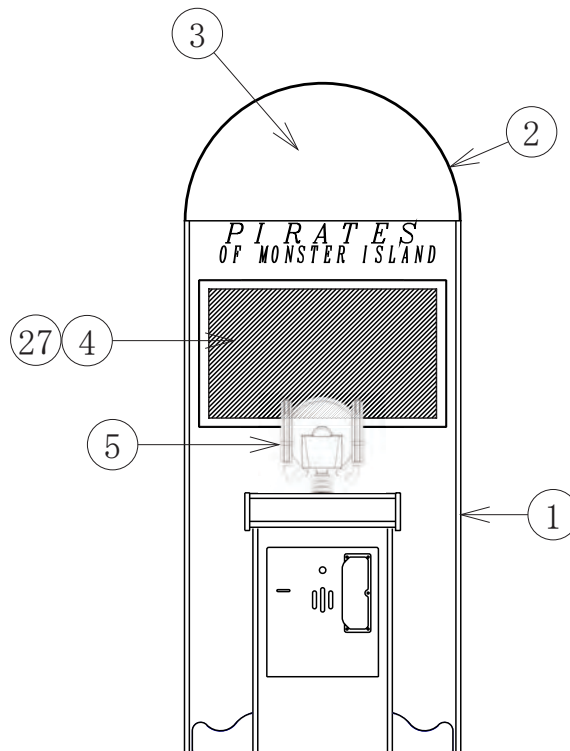

| ITEM NO | PART NUMBER | DESCRIPTION                     | QTY |
|---------|-------------|---------------------------------|-----|
| *1      | PG1001UK    | ASSY CABI MAIN                  | 1   |
| *2      | PG0550UK    | BILLBOARD BOX POMI              | 1   |
| *3      | PG-1060UK   | FEATURE WHEEL / BILLBOARD PLATE | 1   |
| *4      | PG-1005UK   | SAFETY GLASS LCD                | 1   |
| *5      | PG-2000UK   | ASSY CONTROLLER                 | 1   |
| *27     | PG-1280UK   | ASSY LCD DISPLAY                | 1   |

② ASSY POMI MAIN CABI (PG-1000UK)

(D-2/2)

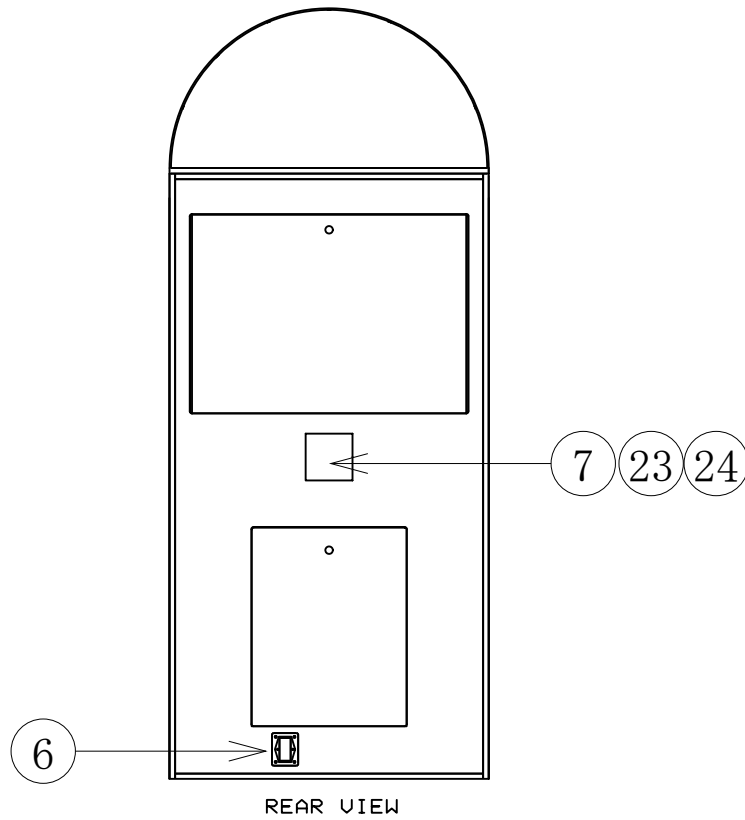

| ITEM NO | PART NUMBER   | DESCRIPTION     | QTY |
|---------|---------------|-----------------|-----|
| *6      | PG-1540UK     | AC UNIT         | 1   |
| *7      | FN1012        | FAN GUARD METAL | 1   |
| *23     | 260-0012-01UK | FAN GUARD METAL | 1   |
| *24     | 105-5340-01   | FAN BKT LONG    | 1   |

③ ASSY FRONT DOOR

(D-1/1)

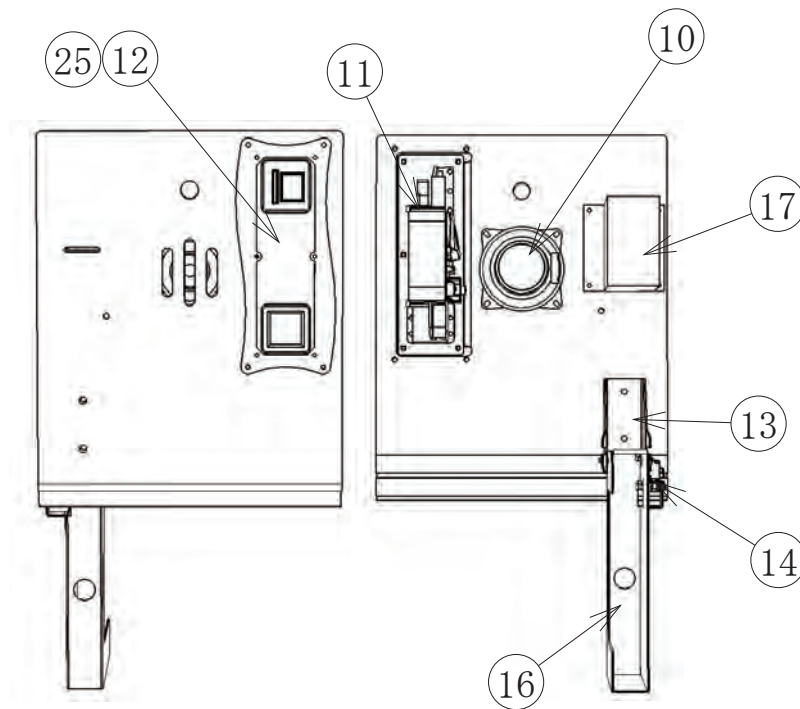

| ITEM NO | PART NUMBER     | DESCRIPTION             | QTY |
|---------|-----------------|-------------------------|-----|
| *10     | 130-008-08015WP | SPEAKER                 | 1   |
| *11     | 220-5610-01     | NRI COIN ACCEPTOR       | 1   |
| *12     | 220-5786-R      | A0710 IL FRONT PLATE    | 1   |
| *13     | PG-1107UK       | BRKT RETAIN TICK HOLDER | 1   |
| *14     |                 | MICROSWITCH             | 1   |
| *16     | PG-1106UK       | TICKET HOLDER           | 1   |
| *17     | 220-0001-01UK   | TICKET VEND UNIT        | 1   |
| *25     | PG-1108UK       | PLATE MOUNT COIN MECH   | 1   |



④ ASSY SW UNIT (PG-0320UK)

(D-1/1)

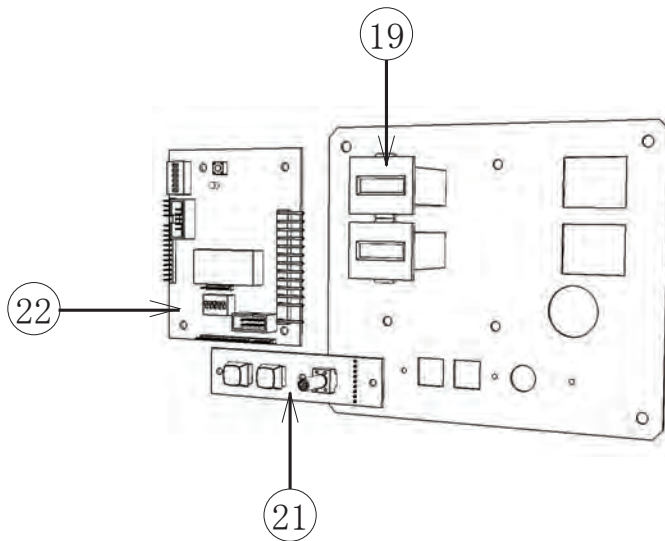
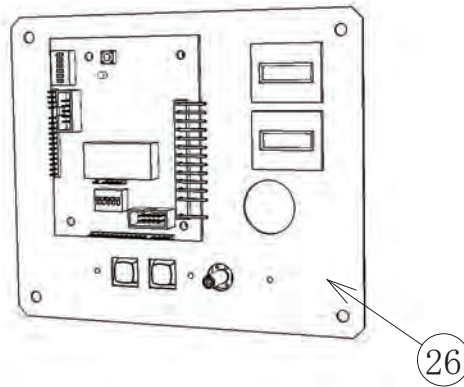

| ITEM NO | PART NUMBER    | DESCRIPTION         | QTY |
|---------|----------------|---------------------|-----|
| *19     | 220-5643UK     | COIN METER SMALL    | 1   |
| *21     | 838-14548-01UK | SW & C VOL BD       | 1   |
| *22     | EP1380-01      | EXCEL CREDIT BD     | 1   |
| *26     | SSR-0321UK     | SW BKT DOUBLE METER | 1   |

## 20 WIRE COLOUR CODE TABLE

### WARNING

The DC power wire color for this product is different from previous SEGA titles. Working from the previous wire colors will create a high risk of fire.

The color codes for the wires used in the diagrams in the following chapter are as follows.

|   |             |
|---|-------------|
| A | PINK        |
| B | SKY BLUE    |
| C | BROWN       |
| D | PURPLE      |
| E | LIGHT GREEN |

Wires other than those of any of the above 5 single colors will be displayed by 2 alphanumeric characters.

|   |        |
|---|--------|
| 1 | RED    |
| 2 | BLUE   |
| 3 | YELLOW |
| 4 | GREEN  |
| 5 | WHITE  |
| 7 | ORANGE |
| 8 | BLACK  |
| 9 | GRAY   |

If the right-hand side numeral of the code is 0, then the wire will be of a single color shown by the left-hand side numeral (see the above).

Note 1: If the right-hand side numeral is not 0, that particular wire has a spiral color code. The left-hand side character shows the base color and the right-hand side one, the spiral color.

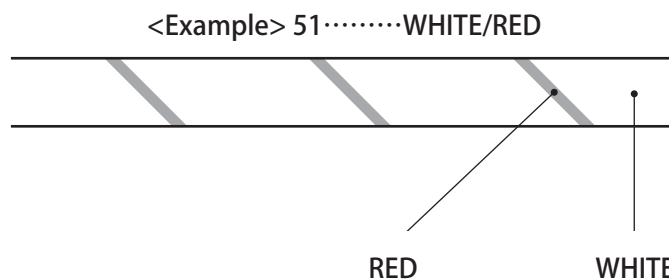

Note 2: The character following the wire color code indicates the size of the wire.

|        |       |
|--------|-------|
| U:     | AWG16 |
| K:     | AWG18 |
| L:     | AWG20 |
| None : | AWG22 |

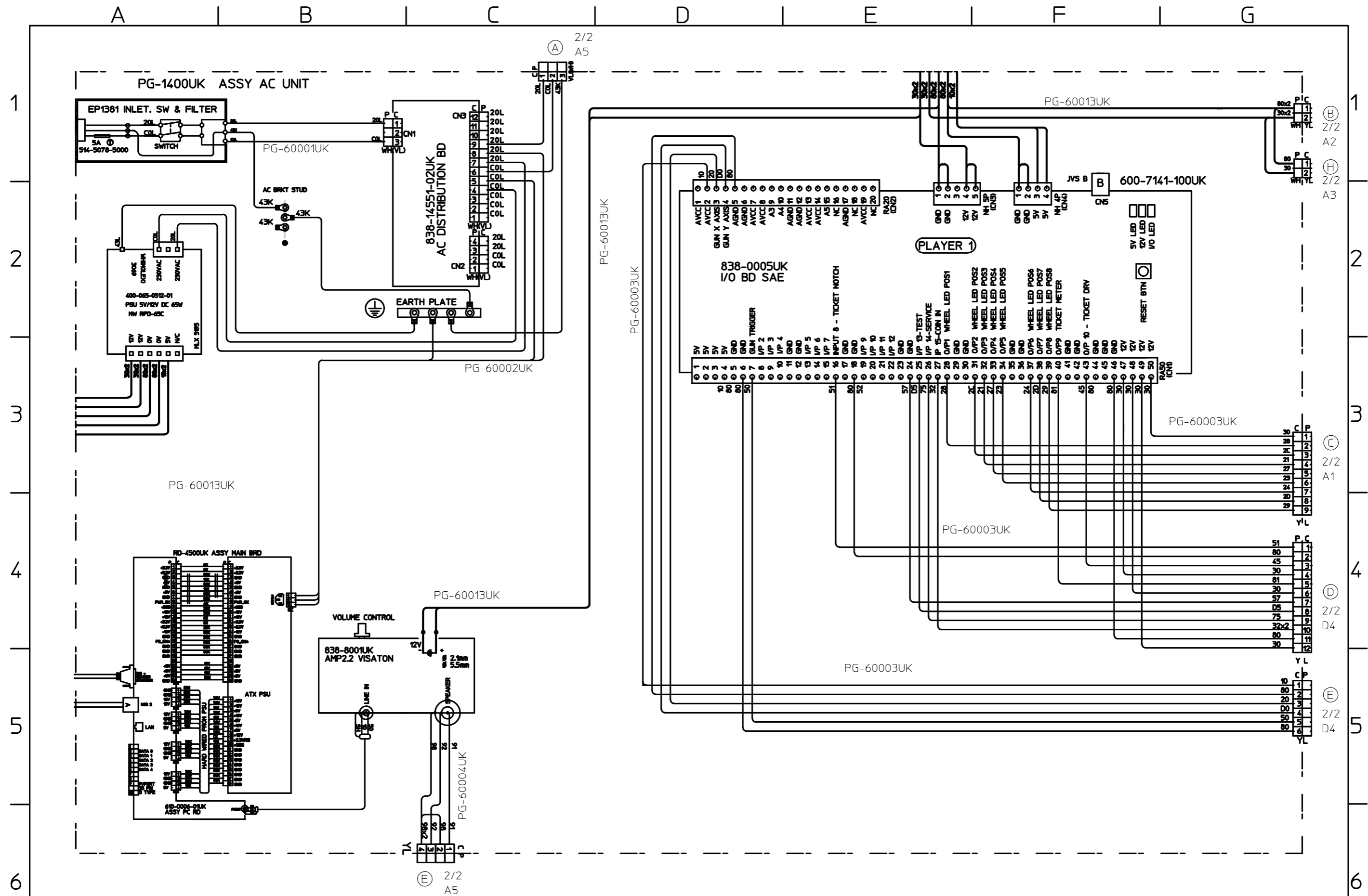

|            |  |  |  |  |                |                       |          |   |   |                           |
|------------|--|--|--|--|----------------|-----------------------|----------|---|---|---------------------------|
| ALTERATION |  | 8 BLACK<br>7 ORANGE<br>5 WHITE<br>4 GREEN<br>3 YELLOW<br>2 BLUE<br>1 RED | E LIGHT GREEN<br>D PURPLE<br>C BROWN<br>B SKY BLUE<br>A PINK<br>9 GRAY | A3 EARTH WIRE<br>U JAM516 UL 505<br>V JAM518 UL 505<br>W JAM520 UL 507<br>X JAM522 UL 507<br>Y JAM524 UL 507 | DRAWN BY<br>RA | PG-0000UK<br>TOP_ASSY | 16/07/12 | SEGA CORPORATION<br>PIRATES OF MONSTER ISLAND | THIS DRAWING WILL IN NO WAY BE COPIED,<br>TO BE RETURNED ON DEMAND. | PAGE 1 / 2<br>DIAGRAM No. |
|------------|--|--|--|--|----------------|-----------------------|----------|---|---|---------------------------|

(D-2/3)

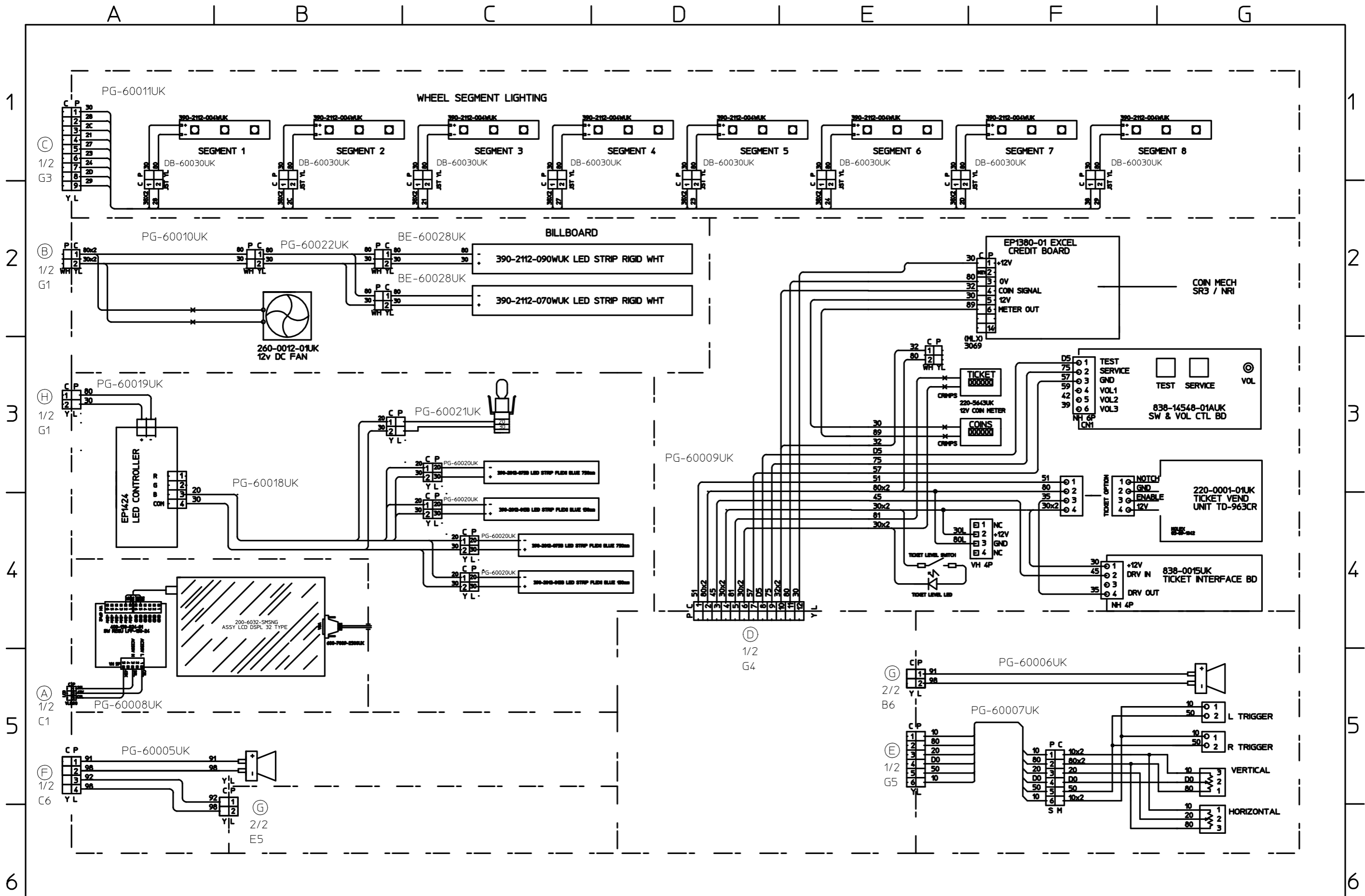

|   |        |   |             |    |              |
|---|--------|---|-------------|----|--------------|
| 8 | BLACK  | E | LIGHT GREEN | 43 | EARTH WIRE   |
| 7 | ORANGE | D | PURPLE      | U  | AWG16 UL 100 |
| 5 | WHITE  | C | BROWN       | K  | AWG18 UL 100 |
| 4 | GREEN  | B | SKY BLUE    | L  | AWG22 UL 100 |
| 3 | YELLOW | A | PINK        | M  | AWG22 UL 100 |
| 2 | BLUE   | 9 | GRAY        | Y  | AWG22 UL 100 |
| 1 | RED    |   |             |    |              |

|           |          |          |
|-----------|----------|----------|
| PG-0000UK | DRAWN BY | RA       |
| TOP_ASSY  | DATE     | 16/07/12 |

|                           |             |  |
|---------------------------|-------------|--|
| SEGA CORPORATION          |             | THIS DRAWING WILL IN NO WAY BE COPIED, TO BE RETURNED ON DEMAND. |
| PIRATES OF MONSTER ISLAND |             |  |
| ALTERATION                | DESCRIPTION | PAGE 1 / 2   |