

CRAZY CUCKOO

OWNER'S MANUAL

CEC



IMPORTANT

- Please read the manual carefully and keep it in mind before using this machine.
- Put this manual within touch of your reference in anytime.

PRECAUTIONS FOR USE

The following safety precautions are given throughout this manual. They must be strictly followed to protect those who install, use or maintain this product as well as to protect players, visitors and property.

For safety reasons.

- The following suggestions should be adhered to:

WARNING

Disregarding could result in serious injury.

CAUTION

Disregarding could result in injury or product damage.

- The following graphic suggestions describe the types of precautions to be followed.



Indicates a care should be taken.



Forbidden.



Indicates a matter which must be performed.

- Precautions to be followed:

Certain procedures require a qualified in-shop maintenance person or industry specialist. For such instructions, a qualified person must take care of the jobs.

- Otherwise an electric shock, machine trouble, or a serious accident may result.
- Replacing the machine parts, inspecting and maintaining the machines, and troubleshooting must be assigned only to a qualified in-shop maintenance person or industry specialist. This booklet gives instructions that hazardous jobs in particular must be handled by an industry specialist. Qualified in-shop maintenance person and industry specialist are defined as follows.

Qualified in-shop maintenance person

- A service staff shall have experience in operations of game machines. The staff shall be responsible for assembly, installation, inspection and maintenance of the machine.

Industry specialist

- An industry specialist must be engaged in designing, manufacturing, inspecting and servicing amusement machines. He or she must have an education in electrical, electronic and mechanical engineering, and routinely maintain and repair amusement machines.

PRECAUTIONS FOR USE

WARNING

Be sure to consult an industry specialist when setting up, moving or transporting this product.

- This product should not be set up, moved or transported by any one other than an industry specialist.
- When installing this product, set the 4 leg levelers evenly on the floor and make sure that the product is installed stably in a horizontal position. Unstable installation may result in injury or accident.
- When installing this product, do not apply undue force on movable parts. Otherwise, injury and accident may result, or the product may be damaged.

The machine for indoor usage only does not install outside.



Do not set the game machine up near emergency exits.



Protect the game machine from:

- Rain or moisture.
- Direct sunlight.
- Direct heat from air-conditioning and heating equipment, etc..
- Hazardous flammable substances.
- Otherwise an accident or malfunction may result.



Do not place containers holding chemicals or water on or near the game machine.



Do not place objects near the ventilating holes.



Do not bend the power cord by force or place heavy objects on it.



Never plug or unplug the power cord with wet hands.



Never unplug the game machine by pulling the power cord.



CAUTION

Be sure to use indoor wiring within the specified voltage requirements. For extension cord, use the specified rating or more.

Be sure to use the attached power cord.

Never plug more than one cord at a time into the electrical receptacle.



Do not lay the power cord where people walk through.



Be sure to ground this product.



Do not exert excessive force when moving the machine.



For proper ventilation, keep the game machine 100mm(4") away from the walls.

Do not alter the system related dipswitch settings.

♣ PRECAUTIONS FOR USE

⚠ WARNING

If there is any abnormality such as smoke, bad smell or abnormal noise being emitted from the machine, immediately turn OFF the main power switch and unplug the power cord from the receptacle to stop operating it. 

- Using the machine in abnormal conditions could result in fire or accidents.

In case of abnormality

1. Turn OFF the main power switch.
2. Unplug the power cord from the receptacle.
3. Contact your nearest dealer.

Do not leave the power cord plugged in improperly or covered with dust. 

- Doing so could result the power cord periodically.

⚠ CAUTION

Do not use this product anywhere other than industrial areas. 

- Using in a residential area or an area next to a residential area could affect signal reception of radios, television sets, telephones, etc..

- Do not give shock the surface of glass products.

- Please do not play this game if
 - When you do drinking;
 - When your physical condition is not normal;
 - When you are in pregnancy;
 - When you have on a pulse controller;
 - When you have recently experienced a cramp or fainting away while watching TV.
- Avoid excessive force/shock while playing/moving the game.
- While do games, pay attention to surrounding.

Do not plug or unplug the power cord with wet hands. 

In handling the power cord, follow the instructions below. 

- | | |
|---|--|
| • Do not damage the power cord. | • Do not modify the power cord. |
| • Do not bend the power cord excessively. | • Do not twist the power cord. |
| • Do not heat the power cord. | • Do not pull the power cord. |
| • Do not bind the power cord. | • Do not stand on the power cord. |
| • Do not sandwich the power cord. | • Do not drive a nail into the power cord. |

If the power cord or power plug becomes damaged, stop using the machine immediately and ask your nearest dealer to replace the parts.

♣ PRECAUTIONS FOR USE

⚠ WARNING

Be sure to turn OFF the main power switch and unplug the power cord from the receptacle before inspecting or cleaning the machine. 

When replacing parts, be sure to use parts of the correct specifications. Never use parts other than the specified ones. 

Opening inside the machine shall be done by machine specialist only as high electric current is being sent inside. For game machine with monitor, a care should be taken while opening its back door. If not, a damage to the inside parts or the monitor may occur. 

If the sub power switch of the service panel is turned OFF without turning OFF the main power switch of the power supply unit, some parts in the units remain live. When opening the back door, be sure to turn OFF the main power switch and unplug the power cord from the receptacle. 

Strictly refrain from disassembly and repair of parts which are not indicated in this manual, as well as settings and remodeling. 

To clean the game machine, wipe it with a soft cloth dampened in a neutral detergent.

- Using thinner or other organic solvent or alcohol may decompose the material.
- Electrical shock or equipment failure could be caused by water entering the inside of the machine.

⚠ CAUTION

Components in the game are sensitive to vibrations and impact. Care should be used when moving and transporting the game machine. 

Be sure not to let the machine tip over.

Before moving the machine, be sure to turn OFF the main power switch, unplug the power cord from the receptacle and remove the power cord from the machine. 

Before moving take the machine, off the levelers and move it on the casters.

Avoid excessive force while moving the machine.

.....

PRECAUTIONS IN HANDLING

- When setting up, inspecting, maintaining, moving or transporting this product, follow the procedures and instructions set forth in this manual and perform such work safely.
- Do not set up, handle, inspect, maintain, move or transport this product under conditions equivalent to the condition of "WARNING" or "CAUTION" specified in this manual.
- If a new owner is to have this product as a result of transfer, etc., be sure to give this manual to the new owner.

* CONTENTS

1. SPECIFICATION AND DIMENSIONS (2p)
 - 1-1. DIMENSIONS
 - 1-2. SPECIFICATION
2. NAME OF PARTS & STICKER LOCATION (3p)
 - 2-1. NAME OF PARTS
 - 2-2. STICKER LOCATION
3. COMPONENTS (4p)
4. HOW TO ASSEMBLE
 - 4-1. ASSEMBLING Bonus Ass'y (5p)
 - 4-2. HOW TO BALL SETTING
5. SETUP MODE
 - 5-1. The first step of SETUP MODE (7p)
 - 5-2. Ticket values on the sheet (8p)
6. CLEAR MODE
 - 6-1. The first step of CLEAR MODE (9p)
7. ERROR NO. (10p)
8. TEST MODE
 - 8-1. The first step of TEST MODE (11p)
 - 8-2. SENSOR OR SWITCH TEST (12p)
9. TROUBLE SHOOTING (13p)
10. ASSEMBLING CRAZY CUCKOOO Ass'y (15p)
 - 10-1.ASSEMBLING COIN BOX Ass'y
 - 10-2.ASSEMBLING BONUS Ass'y
 - 10-3.ASSEMBLING POWER SWITCH Ass'y
 - 10-4.ASSEMBLING MAIN BOARD Ass'y (CEC)
 - 10-5.ASSEMBLING POWER SMPS Ass'y (CEC)
 - 10-6.ASSEMBLING NOISE FILTER Ass'y
 - 10-7.ASSEMBLING BALL SLOPE Ass'y
 - 10-8.ASSEMBLING CUCKOO HOUSE Ass'y
 - 10-9.ASSEMBLING TICKET BOX Ass'y
 - 10-10.ASSEMBLING TICKET FND Ass'y (CEC)
 - 10-11.ASSEMBLING PENDULUMTOP LED Ass'y
 - 10-12.ASSEMBLING FRONT DISPLAY ACRYL-L Ass'y
 - 10-13.ASSEMBLING FRONT DISPLAY ACRYL-R Ass'y
 - 10-14.ASSEMBLING COIN SLOPE Ass'y
 - 10-15.ASSEMBLING COIN CHECK Ass'y
 - 10-16.ASSEMBLING SIDE LED LIGHT BKT Ass'y
 - 10-17.ASSEMBLING SIDE LED LIGHT BKT Ass'y_mir
 - 10-18.ASSEMBLING SIDE TOP LED LIGHT BKT Ass'y
 - 10-19.ASSEMBLING SIDE TOP LED LIGHT BKT Ass'y_mir
 - 10-20.ASSEMBLING TAIL PULLEY BEARING Ass'y
 - 10-21.ASSEMBLING ELEVATOR Ass'y
 - 10-22.ASSEMBLING PENDULUM Ass'y
 - 10-23.ASSEMBLING PENDULUM MOTOR Ass'y (CEC)
 - 10-24.ASSEMBLING WHEEL MOTOR Ass'y
 - 10-25.ASSEMBLING ROTARY WHEEL Ass'y
 - 10-26.ASSEMBLING BONUS GAME PLATE Ass'y
 - 10-27.ASSEMBLING CASE Ass'y (CEC)
 - 10-28.ASSEMBLING CRAZY CUCKOO ALL FIX Ass'y (CEC)
11. SHEET (42p)
12. WIRE DIAGRAM (44p)

1. SPECIFICATION AND DIMENSIONS

1-1. DIMENSIONS

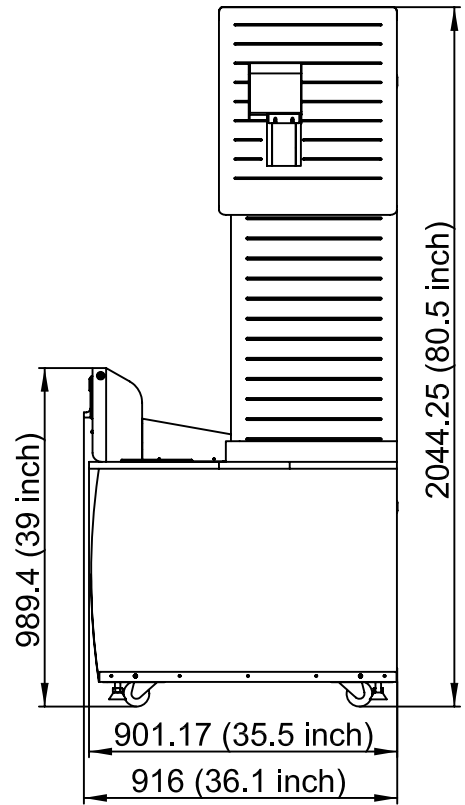
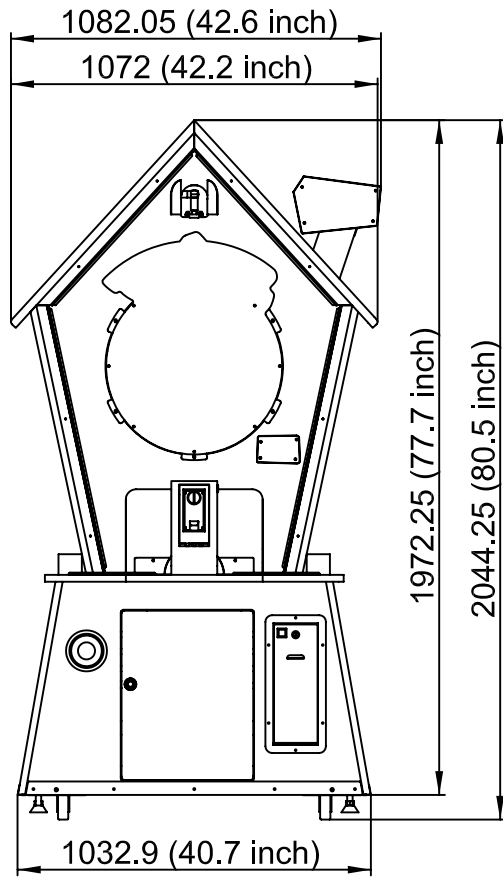

1-2. SPECIFICATION

NOMINATED VOLTAGE RANGE	AC 110V	AC 230V
FUSE	5A	3.15A
NOMINATED FREQUENCY RANGE	50Hz ~ 60Hz	
AVERAGE POWER CONSUMPTION	125W	88W
MAXIMUM POWER CONSUMPTION	160W	179W
WEIGHT	181kg (400Lb)	

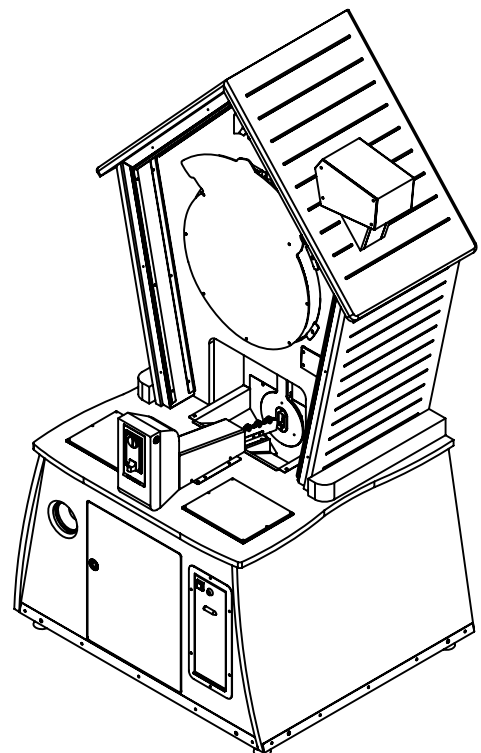

2. NAME OF PARTS & STICKER LOCATION

2-1. NAME OF PARTS

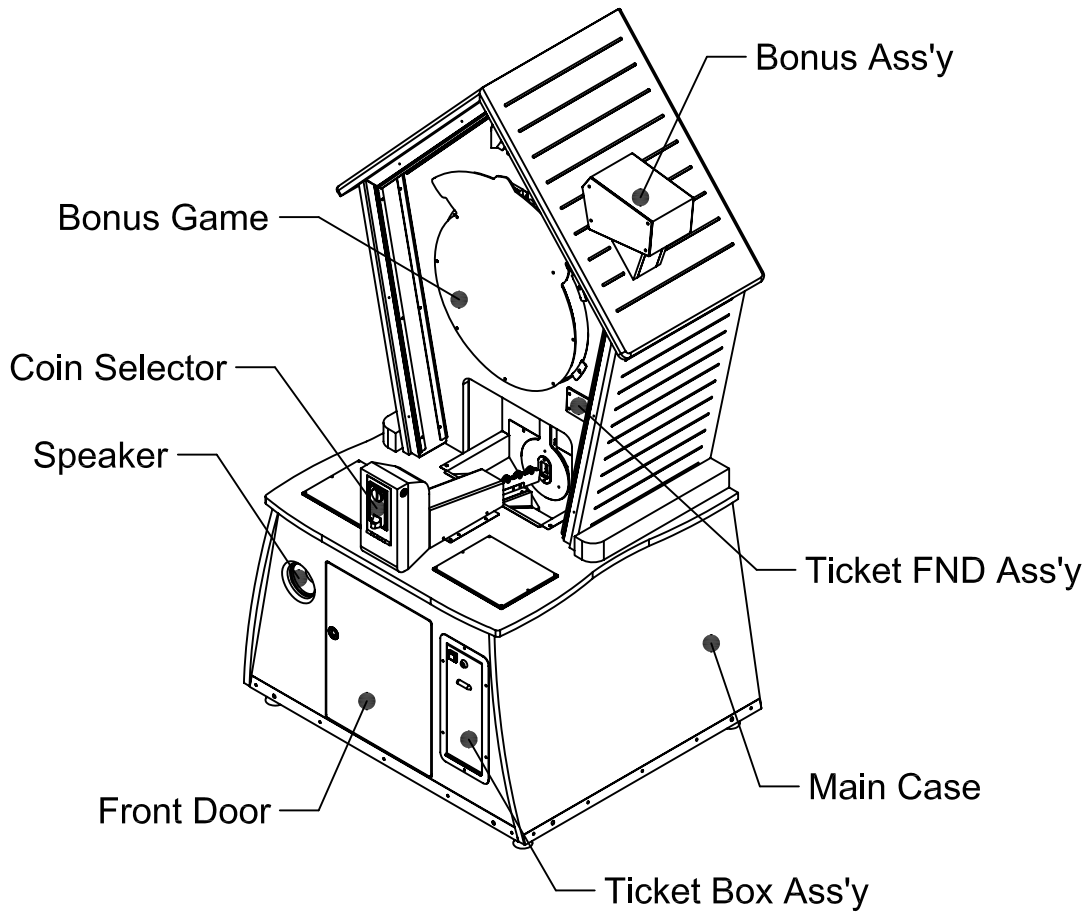

2-2. STICKER LOCATION

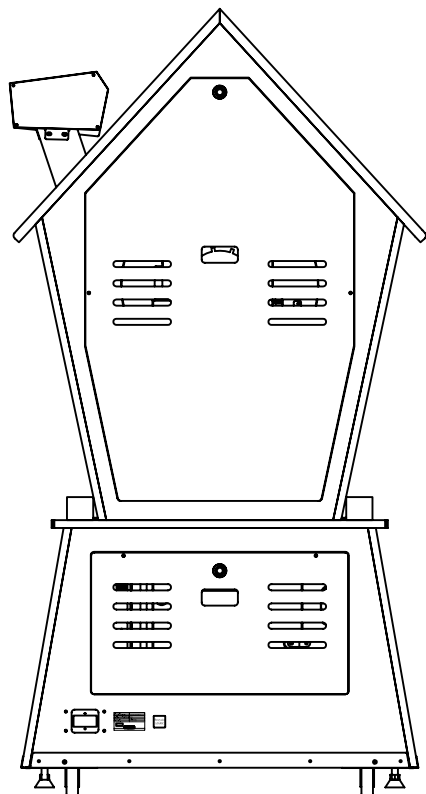

①

MODEL NAME	CRAZY CLUCKOO (CEC)
POWER REQUIREMENTS	AC 110V, 50Hz ~ 60Hz
AVERAGE POWER CONSUMPTION	125W
MAXIMUM POWER CONSUMPTION	160W
WEIGHT (KG)	181kg (400lb)
MODEL NO.	KM-CCK002
ROHS	

②

Recycle
MARK

3. COMPONENTS

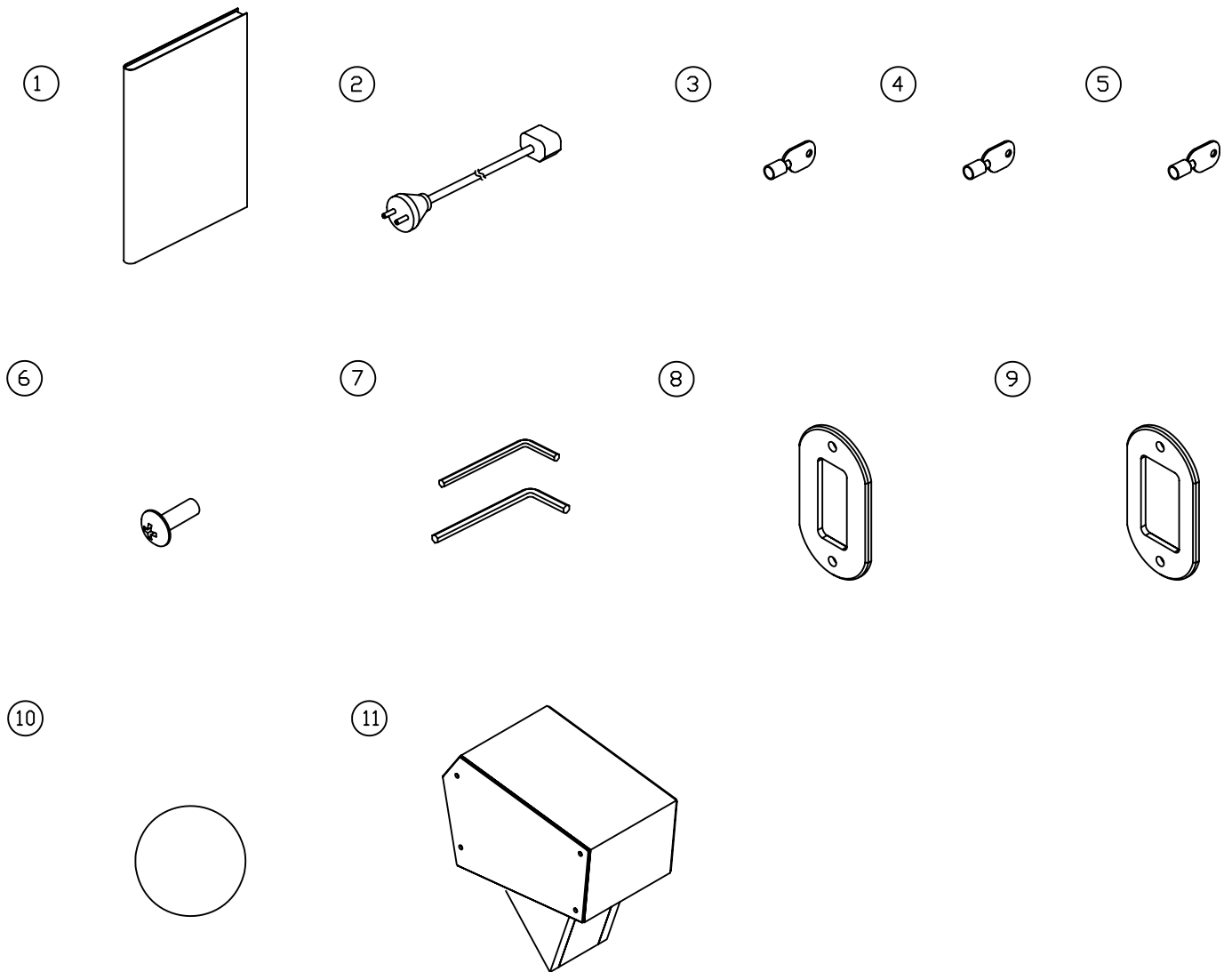

NO.	PART NAME	SPEC.	QUANTITY	CODE NO.
1	MANUAL	MANUAL	1	MCRCOBOX002
2	AC POWER CORD	125V-7A(O.75)UL	1	MELEOACP011
		250V-10A(O.75)BF3		MELEOACP006
3	DOOR KEY / TICKET BOX KEY	7001	2	-
4	CASH BOX KEY	6001	2	-
5	COIN BOX KEY	8001	2	-
6	BOLT (TH)	M4x20L	2	-
7	WRENCH	3mm	1	MXXXOREN004
		4mm	1	MXXXOREN002
8	GUIDE ACRYL 20 X 45	CLEAR PC-3.0t	1	MCRCOSHE015
9	GUIDE ACRYL 30 X 45	CLEAR PC-3.0t	1	MCRCOSHE017
10	BALL	∅ 35	6	MCUC0000001
11	BONUS Ass'y	-	1	MCRCOMEP100

4. HOW TO ASSEMBLE

4-1. ASSEMBLING Bonuse Ass'y

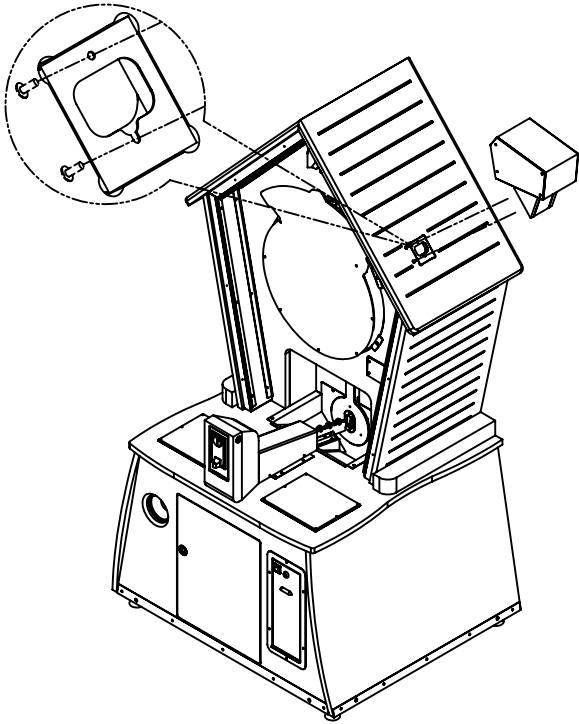

Assemble the Bonus Ass'y on the Bonus Plate BKT with enclosed bolts (TH M4 X 20L)

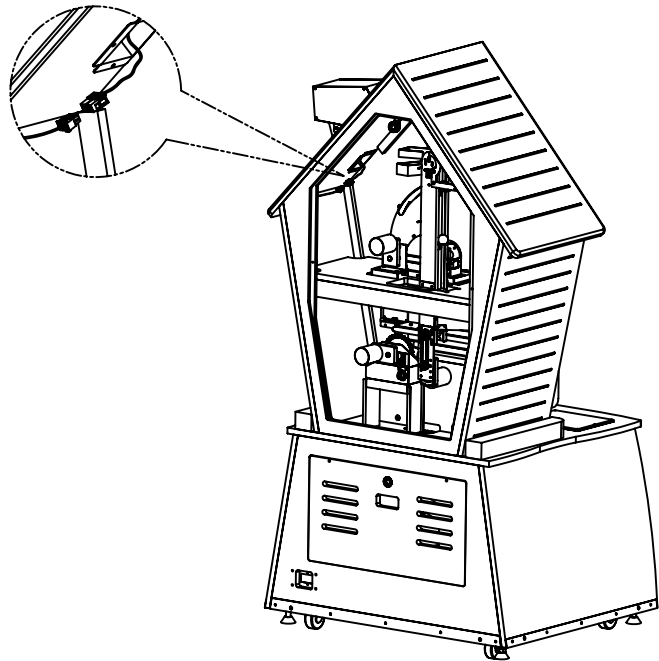

Connect the Jackpot FND (8P) Harness as shown above.

4-2.HOW TO BALL SETTING

①

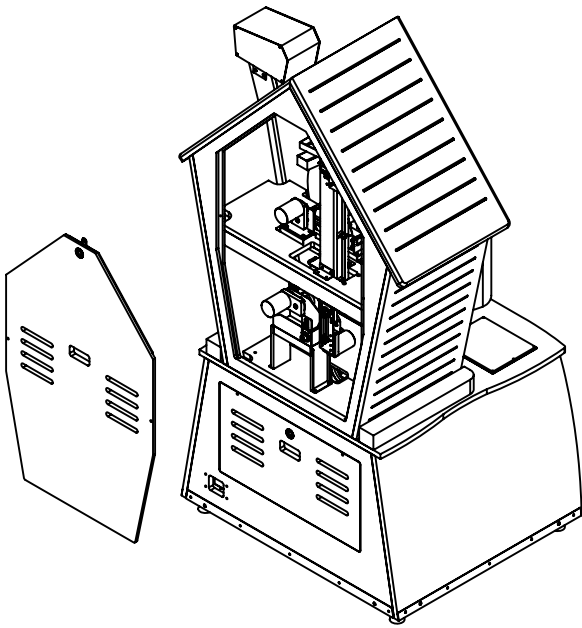

Open the Rear Upper Door as shown above.

②

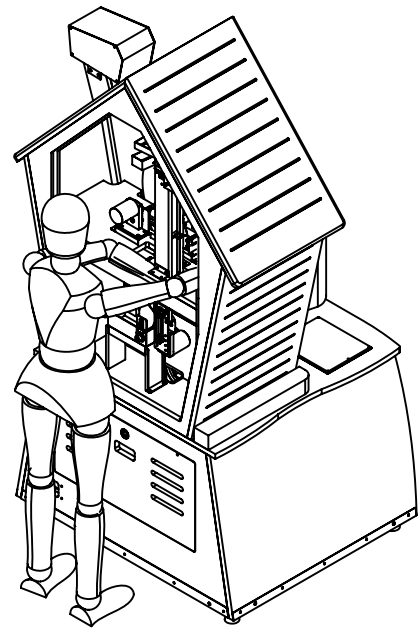

Prepare the 6 Balls and put 5 Balls on Elevator Ball Attachment BKT as shown above.

③

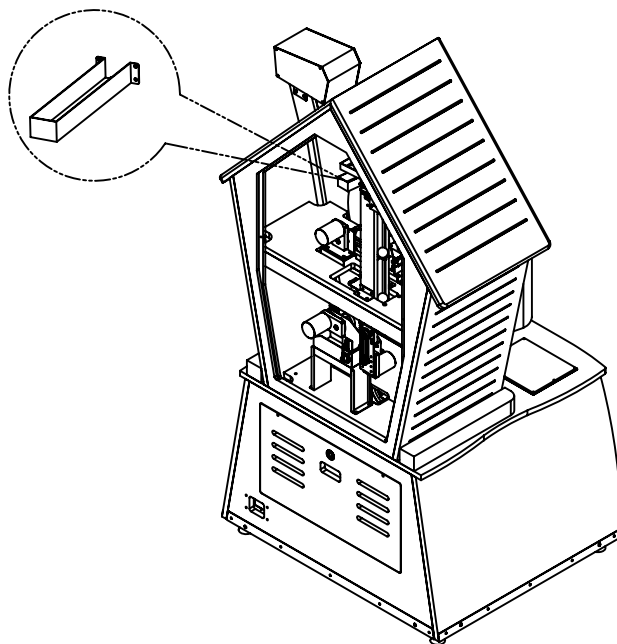

Insert another Ball into SLOPE-3 as shown above.

5. SETUP MODE

5-1. The first step of SETUP MODE

- Push SW1(SETUP) button to get into Setup Mode.
- Push SW2(MOVE) button to move to Setup Mode List.
- Push SW3(SERVICE) button to get into Data Setting Mode.
- Push SW1(SETUP) button to set up the data.

* Get out of the SETUP MODE in the list of REAR.

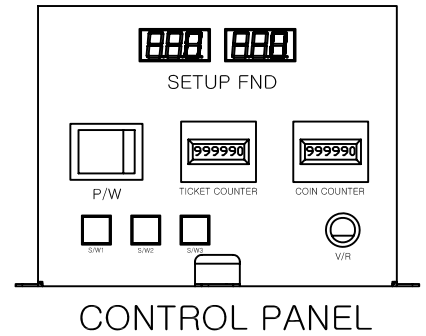
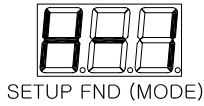

* Setup Mode

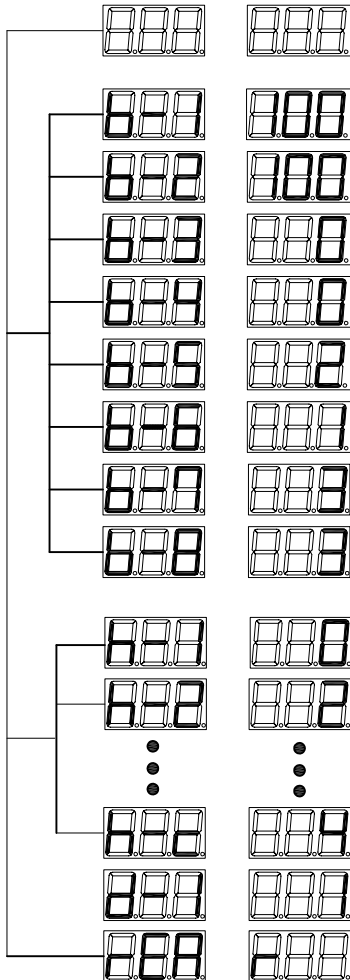

- * JACKPOP INITIAL VALUE(0~999)
- * JACKPOP LIMIT VALUE(0~999)
- * MERCY TICKET(0~9)
- * JACKPOT INCREASE VALUE(0~999)
- * PENDULRUM DIFFICULT(1~9)
- * COINS PER ONE CREDIT(0~9)
- * SPEED OF ROTARY(WHEEL)-(1~9)
- * SPEED OF PENDULUM MOVE(1~9)

- * HOLE TICKET <H-1>
- * HOLE TICKET <H-2>
-
-
-
- * HOLE TICKET <H-c>
- * demo sound on/off(0,1)
- * Return to the GAME MODE after saving Setup Mode.

* factory default setting (CEC): After power off,power on, press sw2.

5-2. Ticket values on the Sheet

CEC Version

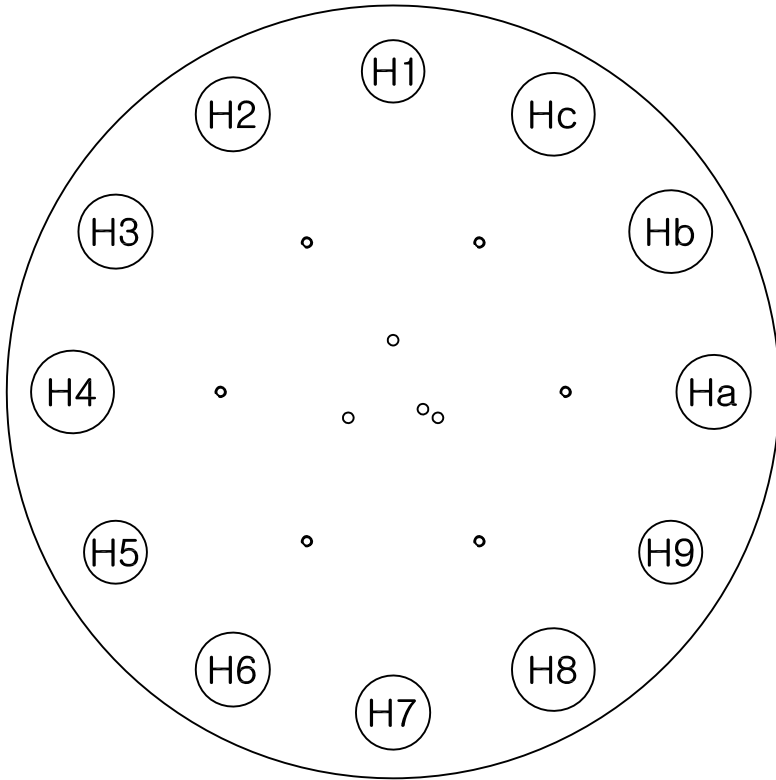

(MAIN BOARD DIP SW)

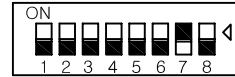

SET DIP #7 TO "ON" POSITION.

- H1 - 0(BONUS)
- H2 - 2
- H3 - 6
- H4 - 4
- H5 - 20
- H6 - 2
- H7 - 6
- H8 - 4
- H9 - 30
- Ha - 2
- Hb - 6
- Hc - 4

6. CLEAR MODE

6-1. The first step of CLEAR MODE

- Push SW1 (SETUP) button to get into Setup Mode.
- Push SW3 (SERVICE) Button to get into Clear Mode.
- Push SW2 (MOVE) button to move to setting values of Clear Mode.
- Push SW3 (ENTER) button to clear the data.

* Push SW1 (SETUP) button to get out of Clear Mode.

* Clear Mode

TICKET OWED FND

SETUP FND

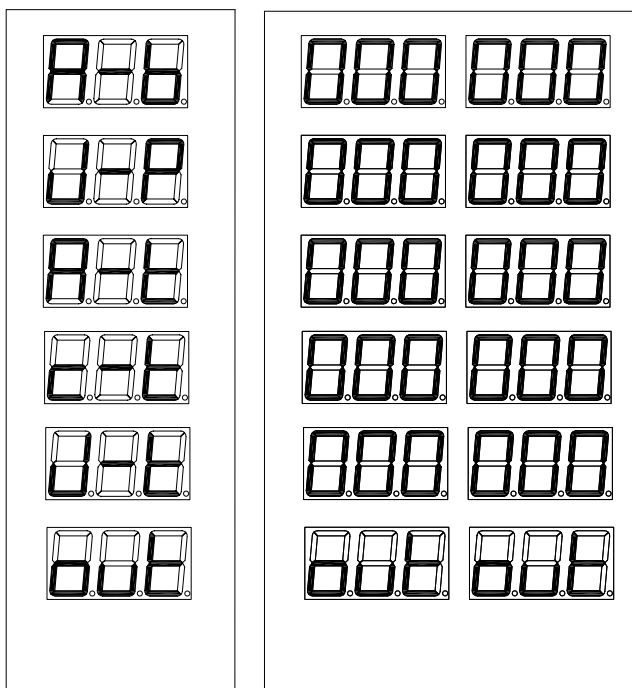

- * Undispensed Tickets .
- * Jackpot Tickets.
- * Total Dispensed Tickets.
- * Total Coin Income.
- * No Use.
- * Get out of the Clear Mode.

* DATA ALL CLEAR (INITIALIZING)

When the power is turned OFF and ON while SW2 being pushed, it is return to the Factory Setting.

(When SW2 is being pushed for 2 or 3 seconds, it displayed at OWED FND).

BONUS FND

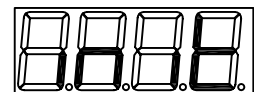

7. ERROR NO.

OWED FND

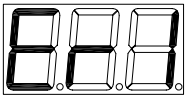

— When the Rotary(Wheel) Motor or Ticket Sensor does not works properly or the machine has no tickets.the error number is displayed at the OWED FND.

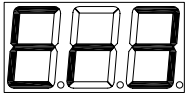

— When the Ticket Motor or Ticket Sensor does not works properly or the machine has no tickets.the error number is displayed at the OWED FND.

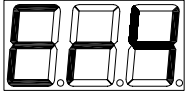

— PENDULUM ERROR

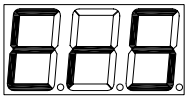

— When the Elevator Motor or Switch does not works properly or the machine has no ball.the error number is displayed at the OWED FND.

8. TEST MODE

8-1. The first step of TEST MODE

- You can get into TEST MODE when the machine turns ON while SW3(SERVICE)being pushed.
- Push SW1(SETUP)button to move to MODE MENU.
- Push SW3(SEVICE)button to set up the setting values.

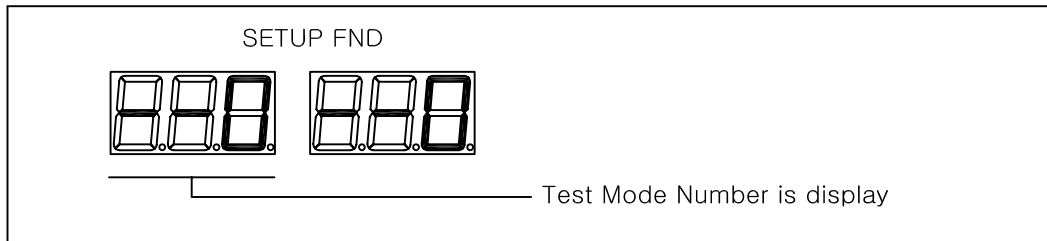

NO.	SETUP FND	CONTENTS
1		ALL DISPLAY OFF
2		ALL DISPLAY ON
3		TICKET DISPENSER MOTOR OFF
4		TICKET DISPENSER MOTOR ON
5		TICKET EMPTY LAMP OFF
6		TICKET EMPTY LAMP ON
7		COIN COUNTER ON(SW3 PUSH)
8		TICKET COUNTER ON(SW3 PUSH)
9		ELEVATOR MOTOR OFF
10		ELEVATOR MOTOR ON
11		ROTARY (WHEEL) MOTOR OFF
12		ROTARY (WHEEL) MOTOR ON
13		PEDULUM MOTOR ON
14		PENDULUM MOTOR OFF
15		BIRD SOL ON/OFF
16		BALL OUT DROP ON/OFF

* SOUND TEST - "S/W 2" SOUND ROOF

8-2. SENSOR or SWITCH TEST

- Followings are displayed at the SETUP FND when each sensor and Switch is sensed.

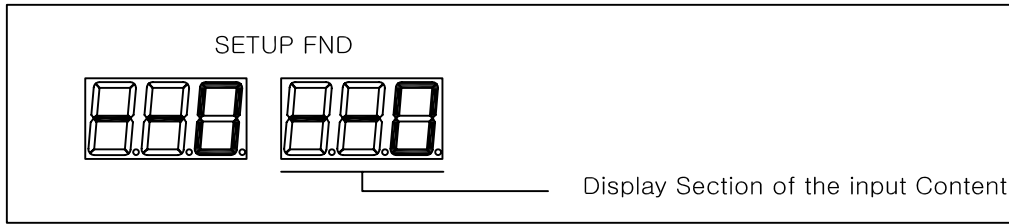

NO.	CONTENTS	SETUP FND
1	TICKET DISPENSER SENSOR	
2	TICKET EMPTY SWITCH	
3	COIN SWITCH	
4	BUTTON SWITCH	
5	ELEVETER SWITCH	
6	BALL OUT SWITCH	
7	POSITION SENSOR	
8	POSITION HOME SENSOR	
9	PENDULUM ENCODER SENSOR	
10	PENDULUM POSITION SENSOR	
11	WIN S/W	

TROUBLESHOOTING TABLE

NO	PROBLEMS	CAUSE	COUNTERMEASURES	REFERENCE PAGE
1	NO POWER ON GAME MACHINE	REAR POWER S/W IS TURNED OFF	TURN ON THE REAR POWER S/W	P39-⑥
		FRONT POWER S/W IS TURNED OFF	TURN ON THE FRONT POWER S/W	P17-②
		FUSE IS BLOWN	CHANGE A FUSE	P19-②
2	NO SOUND	VOLUME IS NOT ADJUSTED	CHANGE VOLUME PCB	P17-⑤
		MAIN BD IS CONDEMNED	EXECUTE SOUND TEST MODE IN TEST MODE	
			CHANGE MAIN BD	P18-①
		CPU BD IS CONDEMNED	EXECUTE SOUND TEST MODE IN TEST MODE	P18-①
CHANGE CPU BD	P18-①			
3	COIN ACCEPTER DOES NOT WORK	COIN MECH REJECT COIN	CHECK COIN MECH IF IT HAS A SAMPLE MEDAL	P15-②
			CONTROL VR OF COIN MECH	P15-②
			CHANGE COIN MECH	P15-②
			CHECK COIN CONNECTOR	P15-②
4	TICKET IS NOT DISPENSED	RED LIGHT ON THE TICKET DISPENSER	CHECK IF TICKET IS EMPTY	
			CHECK IF TICKET IS STUCK	
		TICKET DISPENSER DOES NOT WORK	CHECK CONNECTOR	
			CHANGE TICKET DISPENSER	P22-④
			EXECUTE TICKET TEST IN TEST MODE(8-1, #3~#6 TEST)	
CHANGE MAIN BD	P18-①			
5	PENDULUM DOES NOT MOVE	MOTOR DOES NOT WORK	CHECK THE ELECTRIC VOLTAGE IF YOU MEASURE AT LEAST DC+12V	P34-⑨
			CHECK SENSOR	P34-⑨
			EXECUTE PENDULUM MOTOR TEST MODE IN TEST MODE(8-1, #13~#14)	P9
6	CUCKOO BIRD DOES NOT MOVE	SOLENOID DOES NOT WORK	CHANGE A SOLENOID	P21-⑦
			CHANGE MAIN BD	P18-①
7	BALL IS NOT DROPED	THE MACHINE IS EMPTY	FILL WITH BALLS	P3-⑨
		ELEVATOR DOES NOT WORK	CHECK MICRO SWITCH(N.O)	P32-⑮
		SOLENOID DOES NOT WORK	CHANGE SOLENOID	P20-④
CHANGE MAIN BD	P18-①			
8	DISPLAY LED DOES NOT WORK	CONNECTOR IS WRONG	RECONNECT THE WIRES	
		CHANGE MAIN BD	P18-①	
		WIRING HARNESS IS CUT	RECONNECT THE WIRES	
9	ELEVATOR DOES NOT WORK	HARNESS CONNECTED TO THE MOTOR IS FAULTY	RECONNECT THE WIRES	P32-16
		EMPTY OF BALLS	FILL WITH BALLS(4 BALL AT LEAST)	P3-⑨
		MICRO SW DOES NOT WORKS PROPERLY	CHECK IF SWITCH(#5 OF 8-2) IS WORKS PROPERLY IN TEST MODE	P32-⑮
			CHANGE MICRO SW	P32-⑮
CHANGE MAIN BD	P18-①			

NO	PROBLEMS	CAUSE	COUNTERMEASURES	REFERENCE PAGE
10	THE COIN IS PASSED THROUGH THE HOLE OF PENDULUM, BUT THE BALL IS NOT DROPPED	WIN MICRO SW DOES NOT WORK PROPERLY	CHECK IF SWITCH(#11 OF 8-2) IS WORKS PROPERLY IN TEST MODE	P26-③
			CHANGE MICRO SW	P26-③
			CHANGE MAIN BD	P18-①
		BALL OUT SW DOES NOT WORK PROPERLY	CHECK IF SW(#6 OF 7-2) IS WORKING PROPERLY IN TEST MODE	35-16
			CHANGE MICRO SW	35-16
			CHANGE MAIN BD	P18-①
11	THE SCORE ON THE WHEEL IS NOT CORRECT	ENCODER SNSOR IS FAULTY	CHECK SENSOR WIRING	
			CHANGE SENSOR	P35-⑫
			CHANGE MAIN BD	P18-①
12	THE LETTER ON THE FND IS BROKEN	WIRING HARNESS IS CUT	CHECK THE WIRING HARNESS	
		CONNECTOR IS FAULTY	CHECK THE CONNECTOR	
		INPUT AND OUTPUT ARE SWITCHED	SWITCHCH THE INPUT AND OUTPUT CONNECTOR	
		FND BOARD IS FAULTY	CHANGE FND BOARD	P16-②,P23-②
			CHANGE MAIN BD	P18-①
13	ELECTRIC POWER IS SUPPLIED, BUT THE MACHINE DOES NOT WORK	DC POWER TO SMPS IS CUT OFF	CHANGE THE SMPS	P19-②,③
		CONNECTION OF WIRING IS WRONG	RECONNECT THE WIRES	
		WIRING HARNESS IS CUT	CHECK THE WIRES AND RECONNECT THE WIRES	
		MAIN BOARD IS FAULTY	CHANGE MAIN BD	P18-①
		CPU BOARD IS FAULTY	CHANGE CPU BOARD	P18-②
14	ALL SAVED DATE ARE DELETED	SETUP SW IS WONG	SETUP SW2 IS BEING PUSHED	P17-⑦
			CHANGE SETUP BUTTON PCB	P17-⑦

10.ASSEMBLING CRAZY CUCKOO Ass'y

10-1.ASSEMBLING COIN BOX Ass'y

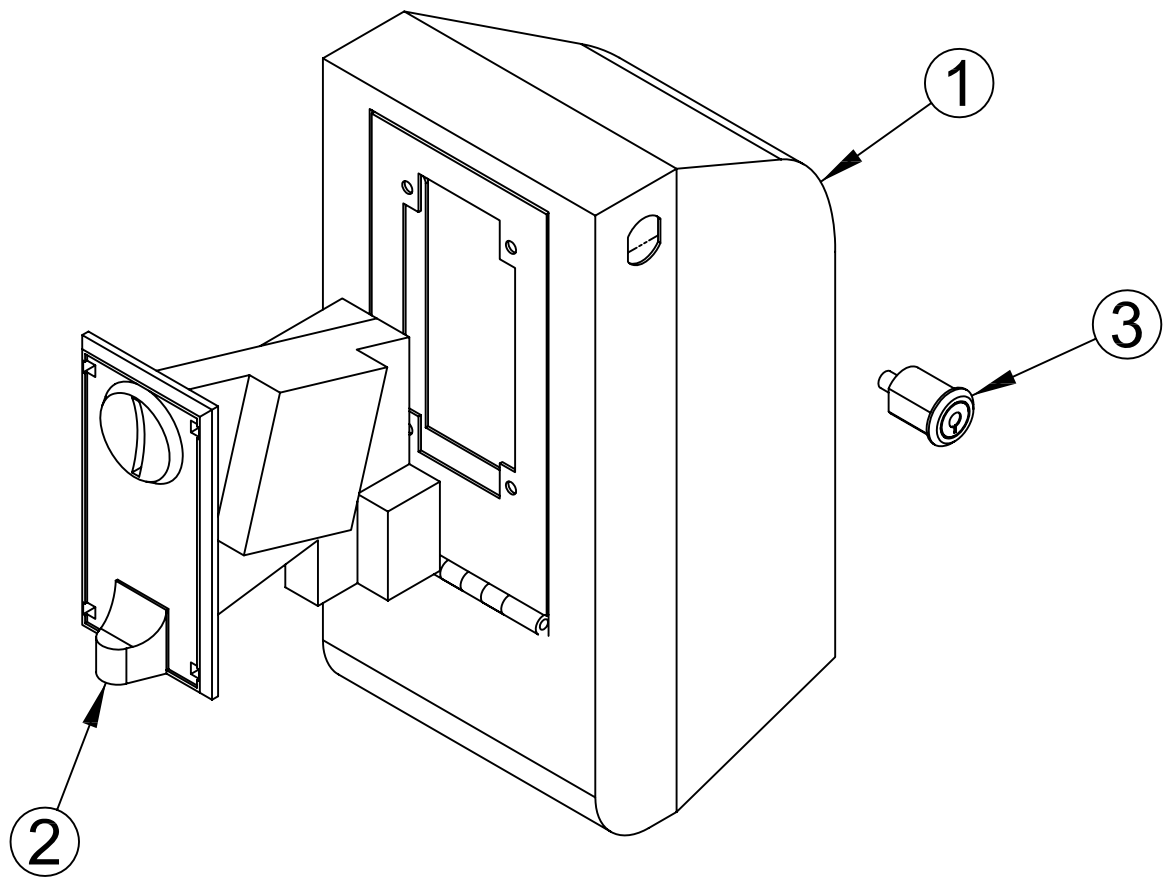

NO.	CODE NO.	QUANTITY	PART NAME	SPEC.
1	MCRC0MEP001	1	COIN DOOR WELD Ass'y	-
2	MZZZ0COS025	1	COIN SELECTOR (T-L)	TW-400
3	MZZZ0KEY046	1	KEY PUSH TYPE	8001

10-2.ASSEMBLING BONUS Ass'y

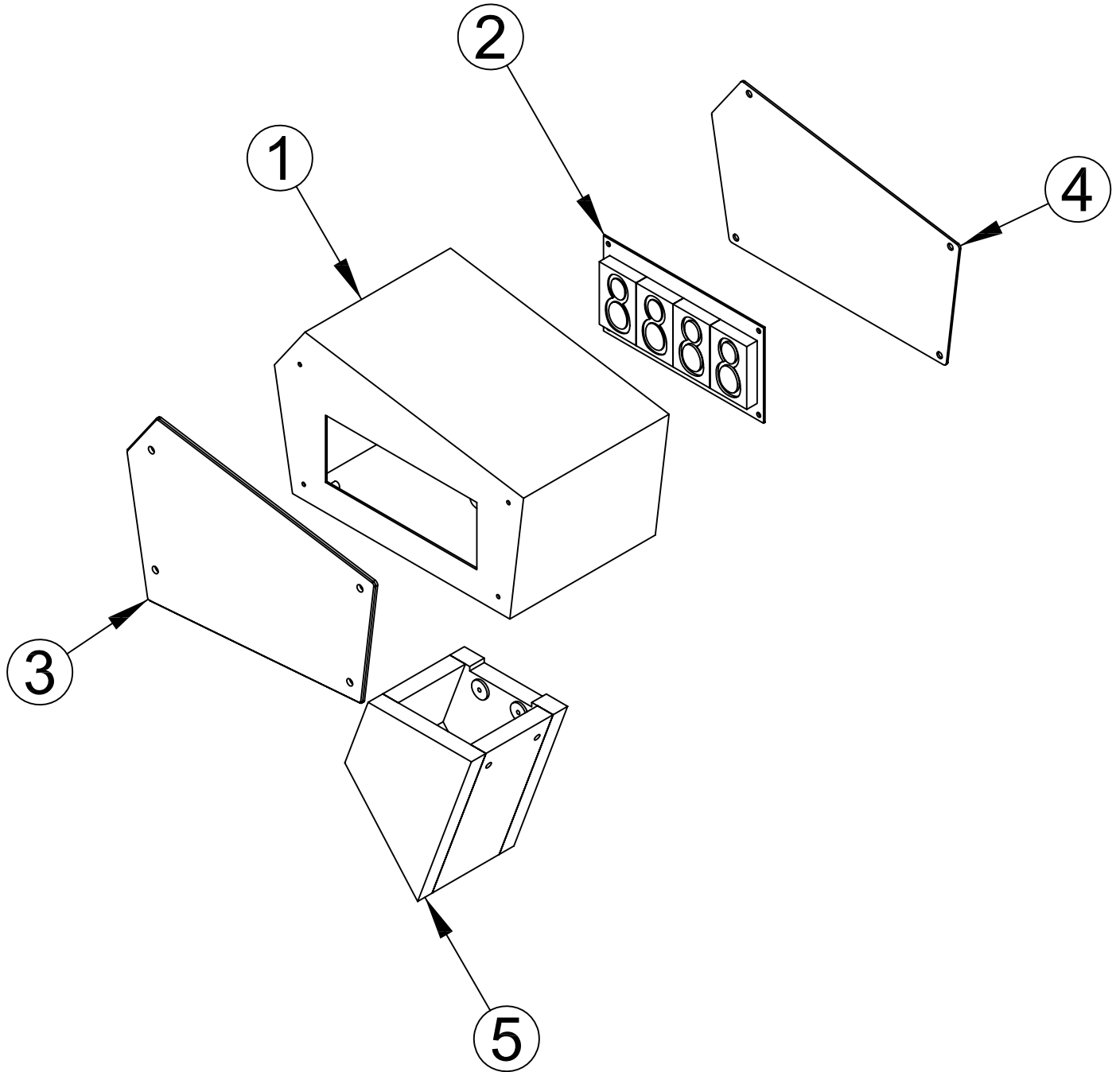

NO.	CODE NO.	QUANTITY	PART NAME	SPEC.
1	MCRC0MEP002	1	BONUS PCB BKT WELD Ass'y	-
2	ACUC0PCB005	1	BONUS FND BOARD	-
3	MCRC0SHE020	1	BONUS ACRYL	CLEAR ACRYL-3.0t
4	MCRC0MEP003	1	BONUS BKT COVER	SPCC-1.6t
5	MCRC0WOO001	1	BONUS PLATE	MDF-15.0t

10-3.ASSEMBLING AC POWER SWITCH Ass'y

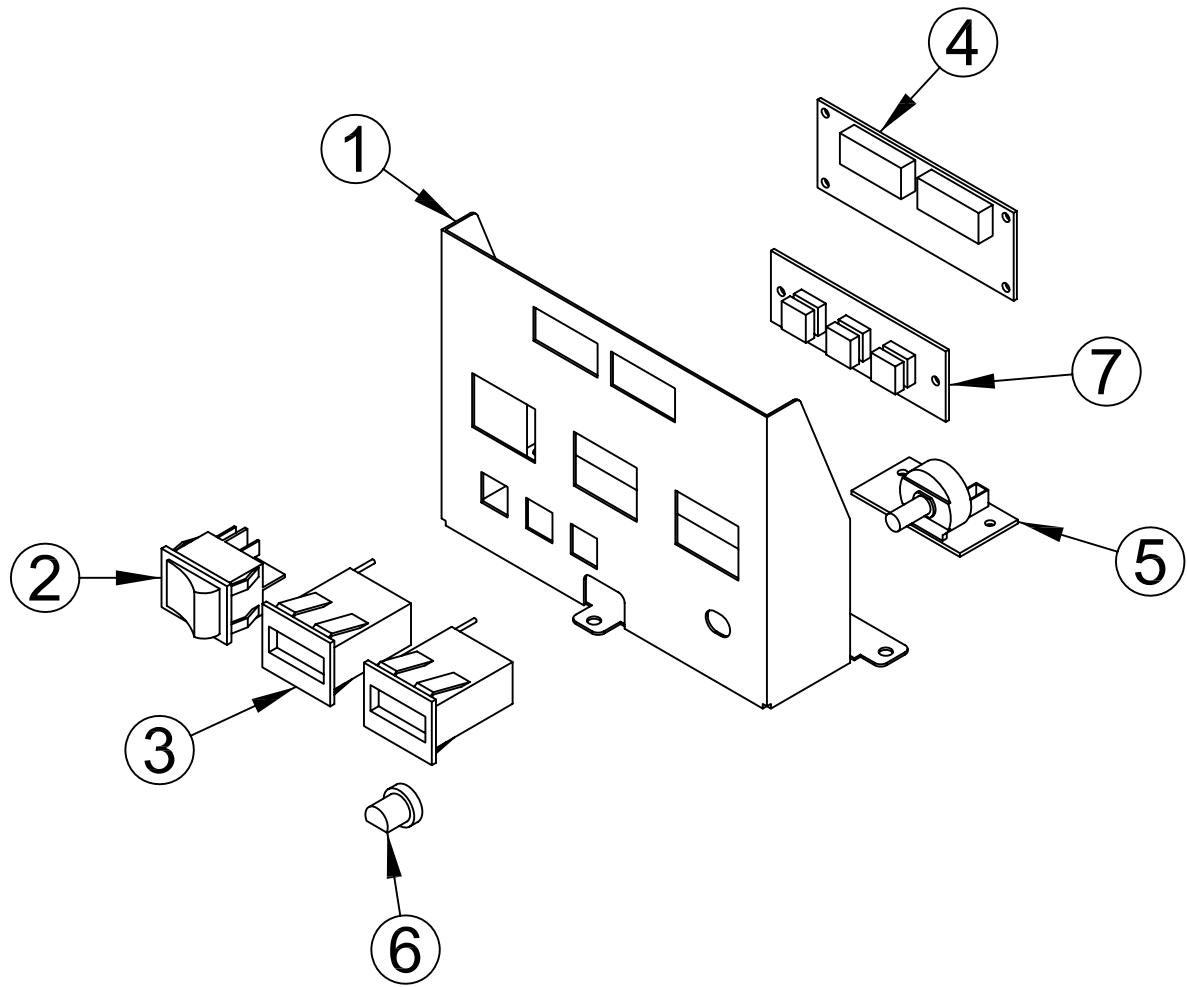

NO.	CODE NO.	QUANTITY	PART NAME	SPEC.
1	MCR00MEP004	1	AC POWER SWITCH BKT	SPCC-1.0t
2	MELE0SWI004	1	ROCKER SWITCH	T-125 4P
3	MZZZ0COU002	2	COUNTER	AMMC-712(OA127CL)
4	AALA0PCB004	1	SETUP FND BOARD	-
5	AMUN0PCB003	1	VR-BOARD-VR-080125	-
6	MELE0VOL007	1	VOLUME KNOB	-
7	AGKM0BOA001	1	SETUP BUTTON BOARD	-

10-4.ASSEMBLING MAIN BOARD Ass'y (CEC)

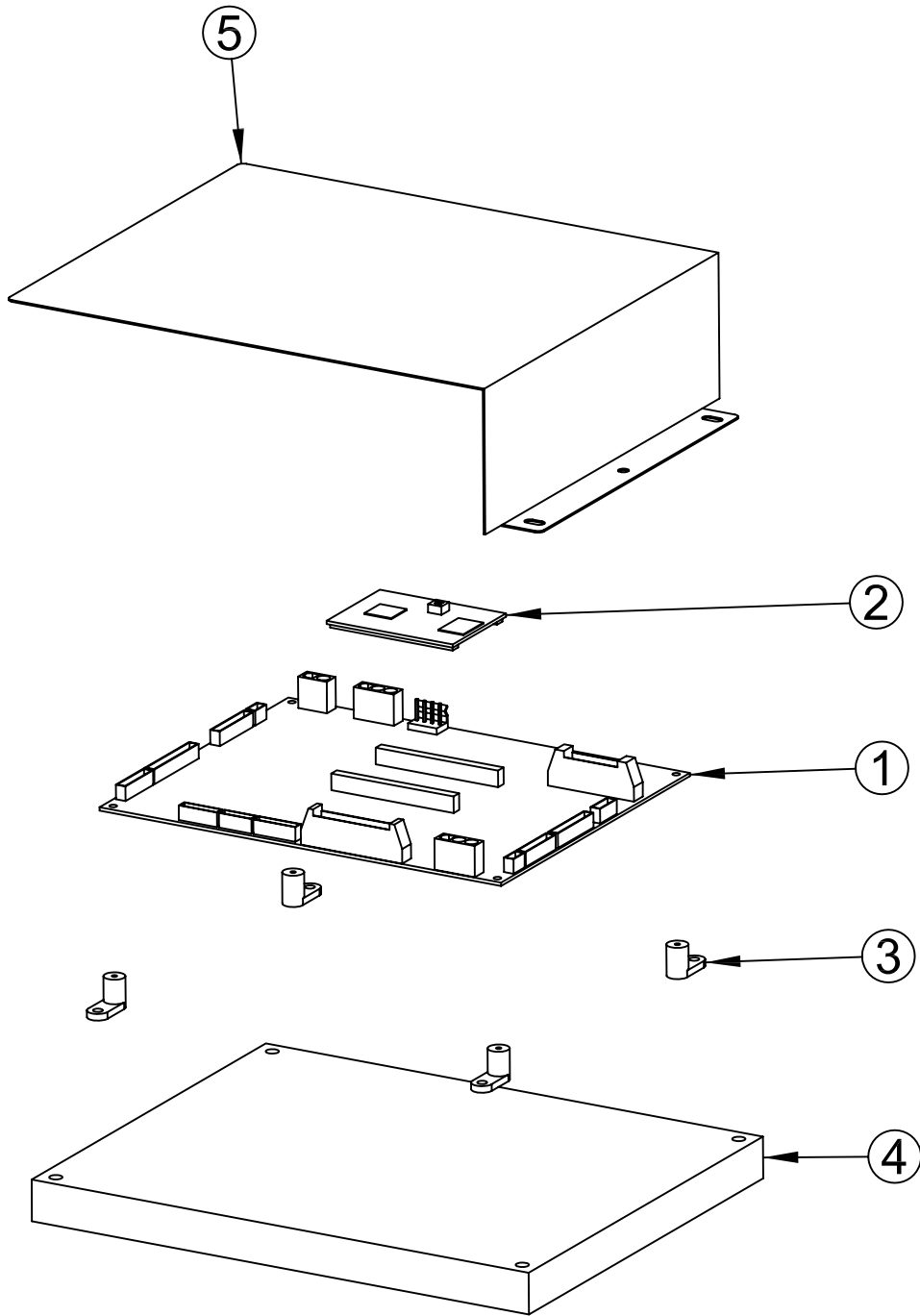

NO.	CODE NO.	QUANTITY	PART NAME	SPEC.
1	ACRC0PCB001	1	MAIN BOARD	-
2	ACRC0PCB002	1	CPU BOARD	-
3	-	4	PCB SUPPORT	-
4	MCRC0WOO009	1	MAIN BOARD PLATE (CEC)	MDF-20.0t
5	MCRC0ACR001	1	MAIN PCB PET COVER	PET-0.8t

10-5.ASSEMBLING POWER SMPS Ass'y (CEC)

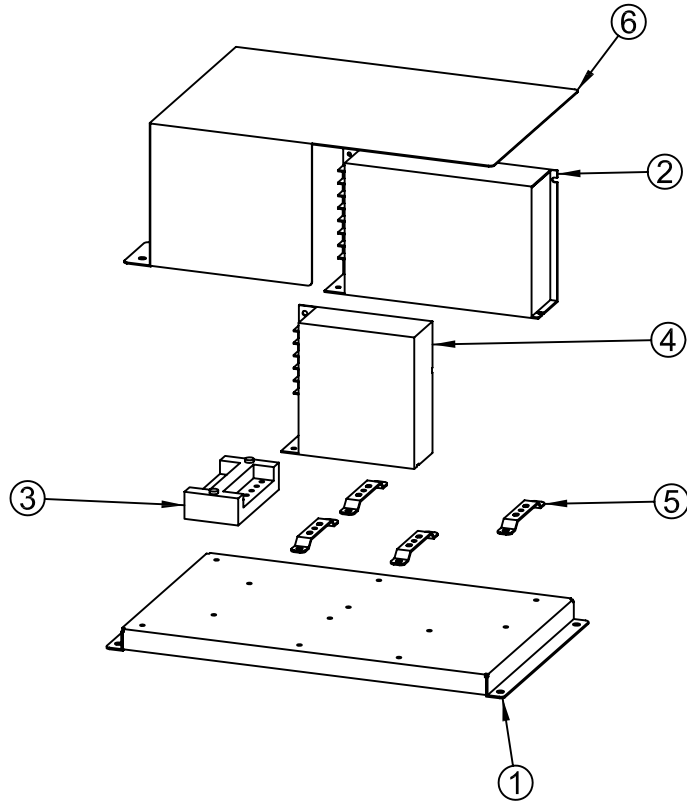

NO.	CODE NO.	QUANTITY	PART NAME	SPEC.
1	MCRC0MEP071	1	POWER SMPS PLATE BKT (CEC)	SPCC-1.2t
2	MELE0SMP034	1	POWER SMPS (RS-100-12)	12V
3	MELE0TEB001	1	TERMINAL BLOCK	6P UL
4	MELE0SMP033	1	POWER SMPS (RS-50-5)	5V
5	MCRC0MEP005	4	SMPS FIX BKT	SPCC-1.2t
6	MCRC0ACR019	1	SMPS PET COVER (CEC)	PET 0.8t

10-6.ASSEMBLING NOISE FILTER Ass'y

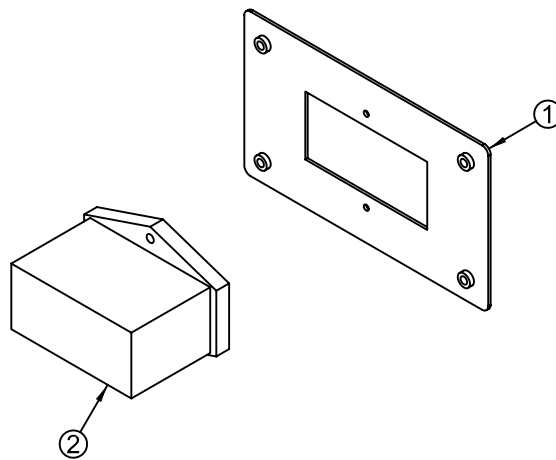

NO.	CODE NO.	QUANTITY	PART NAME	SPEC.
1	MCRC0MEP006	1	AC INPUT BKT	SPCC-1.2t
2	MELE0NOI002	1	NOISE FILTER	IP-0642-H2

10-7.ASSEMBLING BALL SLOPE Ass'y

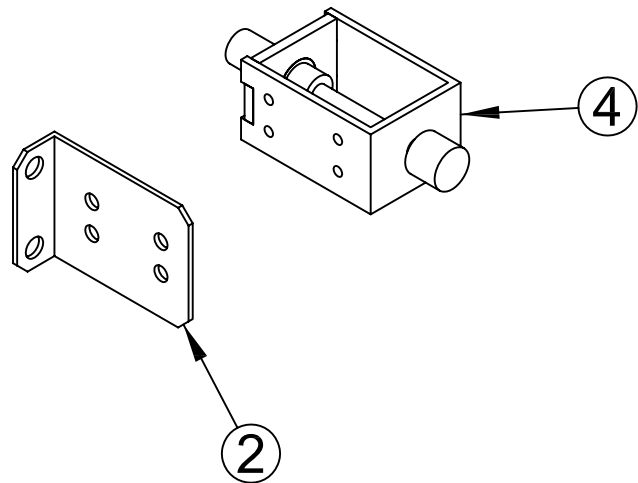
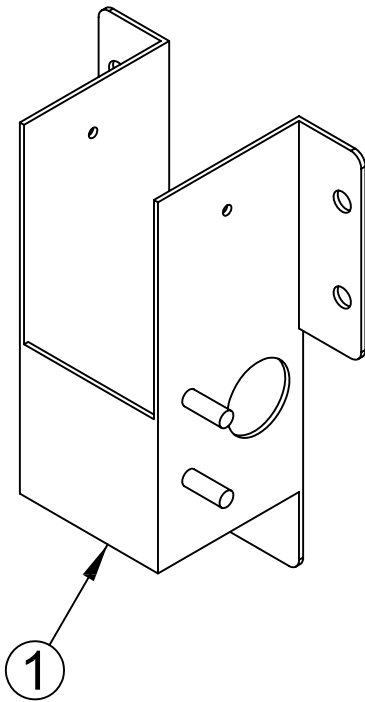
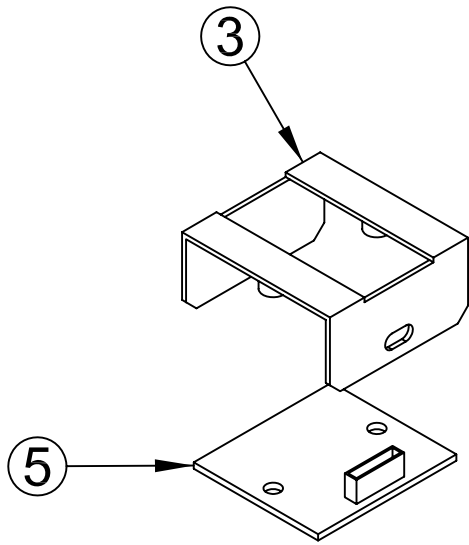

NO.	CODE NO.	QUANTITY	PART NAME	SPEC.
1	MCRC0MEP007	1	SLOPE-2	SPCC-1.2t
2	MCRC0MEP008	1	BALL FIXED SOLENOID BKT	SPCC-1.2t
3	MCRC0MEP009	1	BALL LIGHTING PCB BKT	SPCC-1.2t
4	MCUC0000004	1	SOLENOID	DS-08A (12V)
5	ACU20PCB005	1	BALL LIGHT PCB	-

10-8.ASSEMBLING CUCKOO HOUSE Ass'y

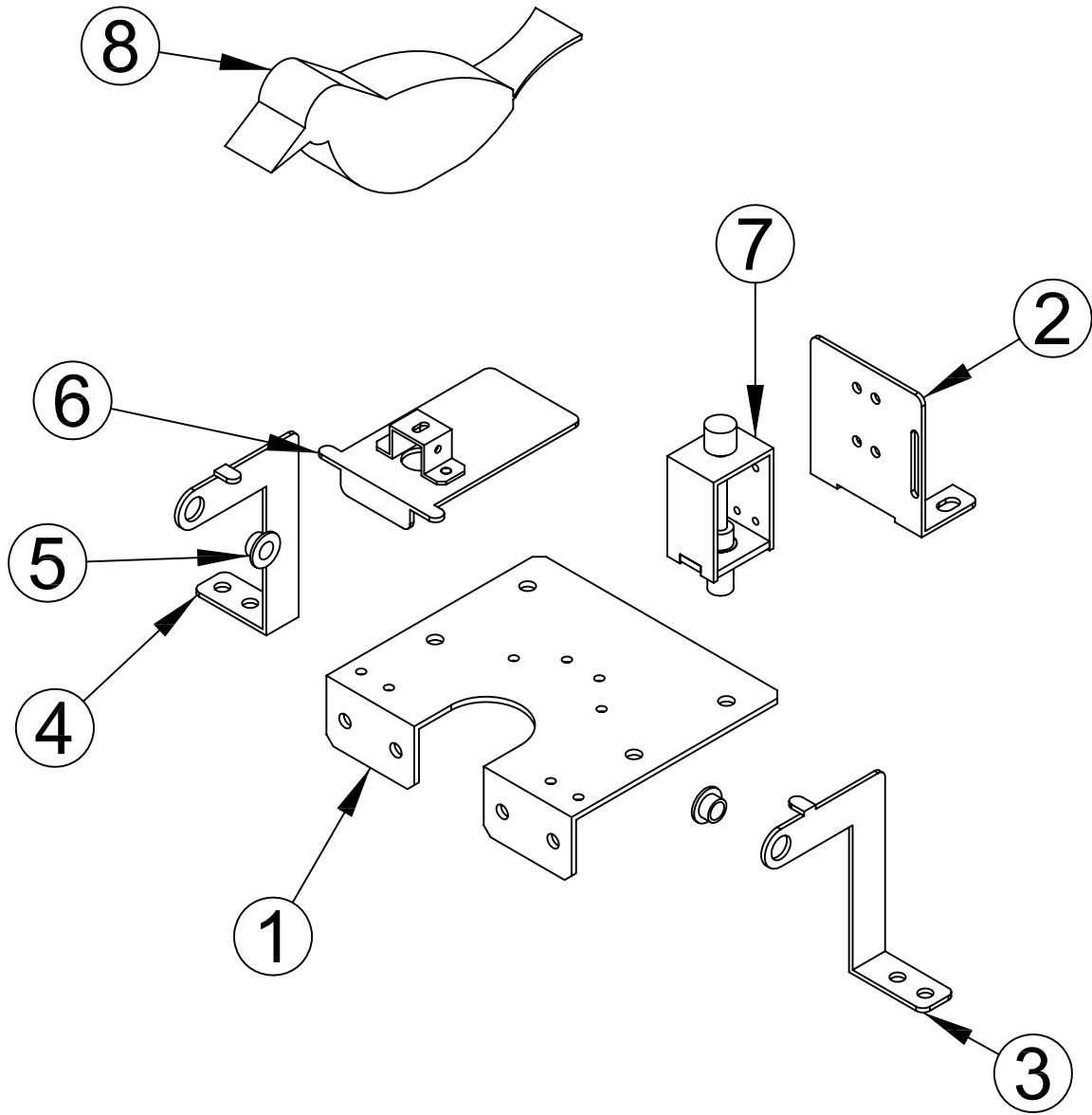

NO.	CODE NO.	QUANTITY	PART NAME	SPEC.
1	MCRC0MEP010	1	CUCKOO BODY	SPCC-2.0t
2	MCRC0MEP011	1	SOLENOID BKT	SPCC-1.6t
3	MCRC0MEP012	1	HINGE BKT	SPCC-1.6t
4	MCRC0MEP013	1	HINGE BKT_mir	SPCC-1.6t
5	MCUC0000006	2	FRANGE DU BUSH	D6 X 6L
6	MCRC0MEP014	1	CUCKOO PLATE WELD Ass'y	-
7	MCUC0000004	1	SOLENOID	DS-08A (12V)
8	MCUC0VAC001	1	CUCKOO VACUUM FORMING	-

10-9.ASSEMBLING TICKET BOX Ass'y

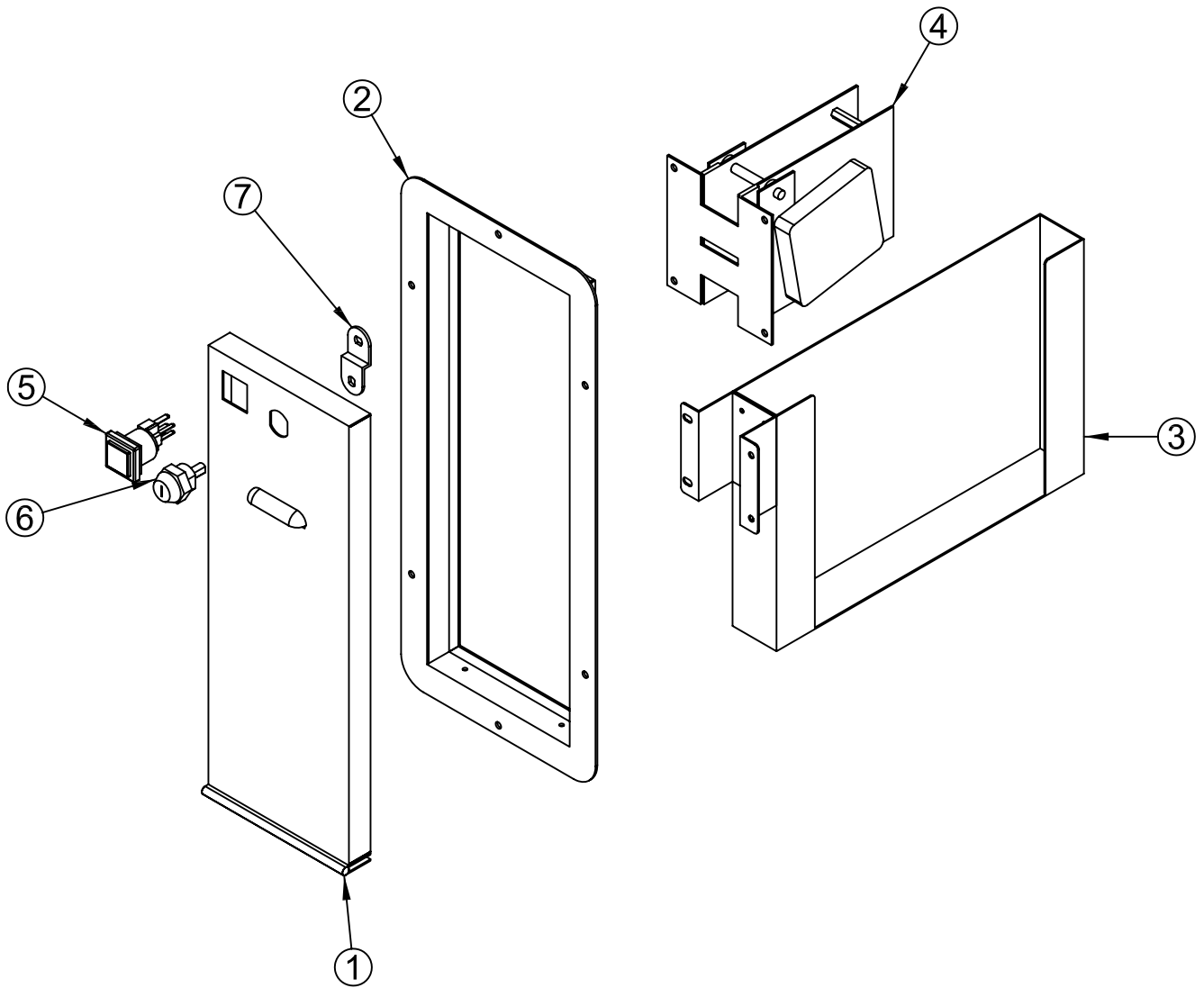

NO.	CODE NO.	QUANTITY	PART NAME	SPEC.
1	MCRC0MEP015	1	TICKET DOOR WELD Ass'y	-
2	MCRC0MEP016	1	TICKET DOOR COVER BKT	SPCC-1.6t
3	MCRC0MEP017	1	TICKET BOX WELD Ass'y	-
4	MZZZ0TID003	1	TICKET DIISPENSOR	CLECO
5	MHA20000007	1	BUTTON	AM1PB-26SH-R12D
6	MZZZ0KEY032	1	KEY Ass'y 7001	7001
7	MCRC0MEP105	1	TICKET KEY PLATE	SPCC-2.0t

10-10.ASSEMBLING TICKET FND Ass'y (CEC)

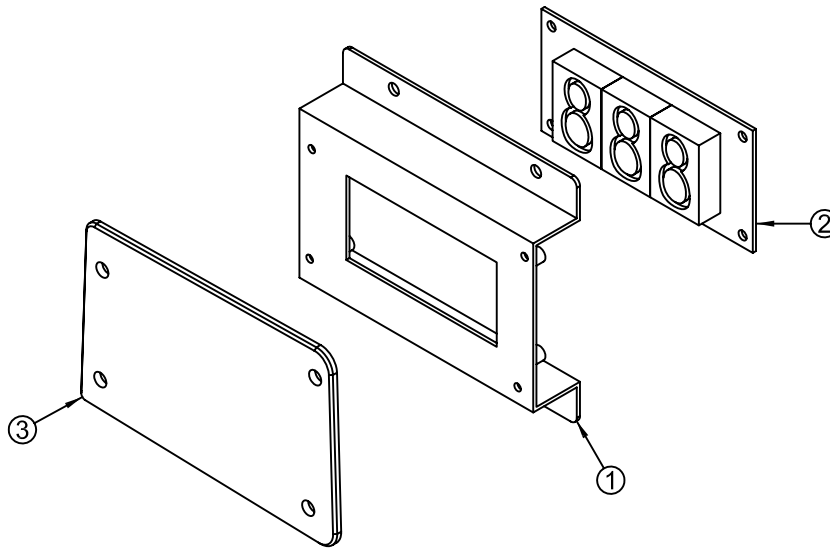

NO.	CODE NO.	QUANTITY	PART NAME	SPEC.
1	MCRC0MEP109	1	TICKET FND BKT (CEC)	SPCC-1.6t
2	ACUC0PCB006	1	TICKET OWED BOARD	-
3	MCRC0SHE014	1	TICKET OWED ACRYL	CLEAR ACRYL-3.0t

10-11.ASSEMBLING PENDULEM TOP LED Ass'y

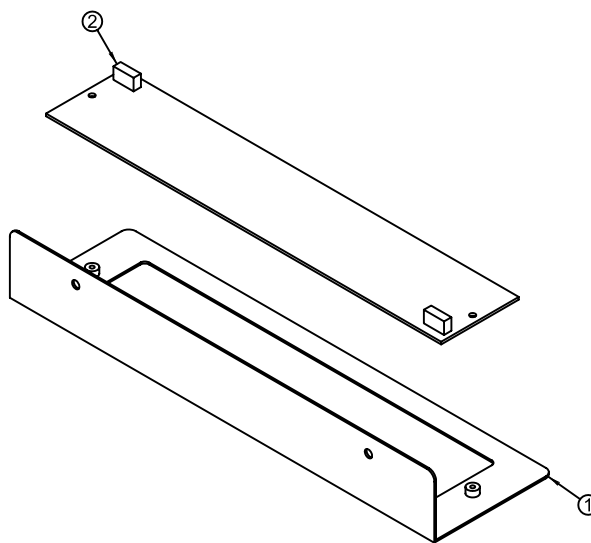

NO.	CODE NO.	QUANTITY	PART NAME	SPEC.
1	MCRC0MEP019	1	PENDULEM TOP LED BKT	SPCC--1.2t
2	ACRC0PCB003	1	PENDULUM TOP LED	-

10-12.ASSEMBLING FRONT DISPLAY ACRYL-L Ass'y

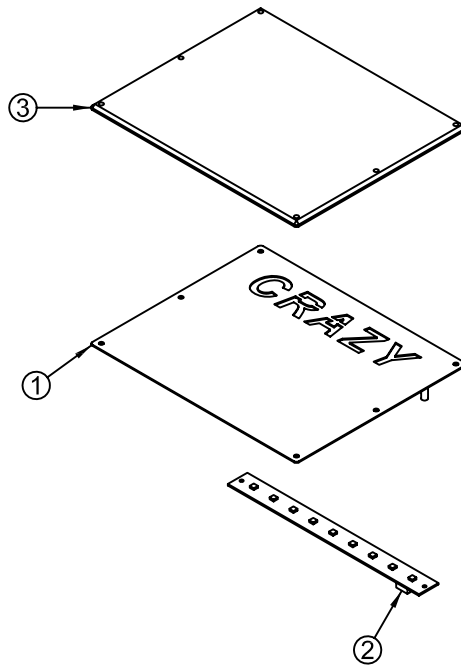

NO.	CODE NO.	QUANTITY	PART NAME	SPEC.
1	MCRC0MEP020	1	FRONT DISPLAY PANEL-L	SPCC-1.2t
2	ACU20PCB002	1	FRONT DISPLAY-L LED BOARD	-
3	MCRC0ACR002	1	FRONT DISPLAY ACRYL-L,R	CLEAR ACRYL-5.0t

10-13.ASSEMBLING FRONT DISPLAY ACRYL-R Ass'y

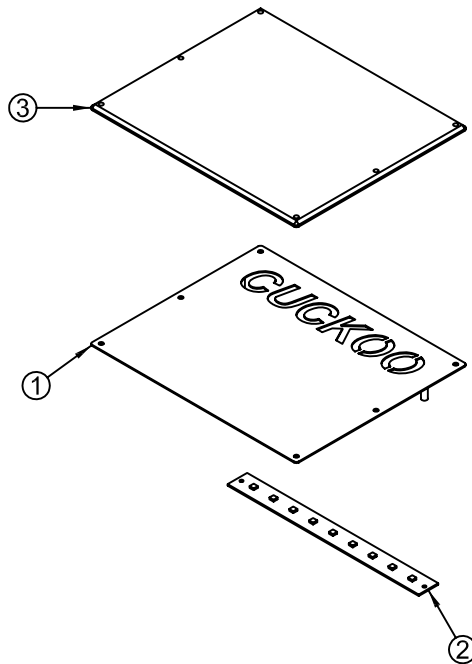

NO.	CODE NO.	QUANTITY	PART NAME	SPEC.
1	MCRC0MEP021	1	FRONT DISPLAY PANEL-R	SPCC-1.2t
2	ACU20PCB002	1	FRONT DISPLAY-L LED BOARD	-
3	MCRC0ACR002	1	FRONT DISPLAY ACRYL-L,R	CLEAR ACRYL-5.0t

10-14.ASSEMBLING COIN SLOPE Ass'y

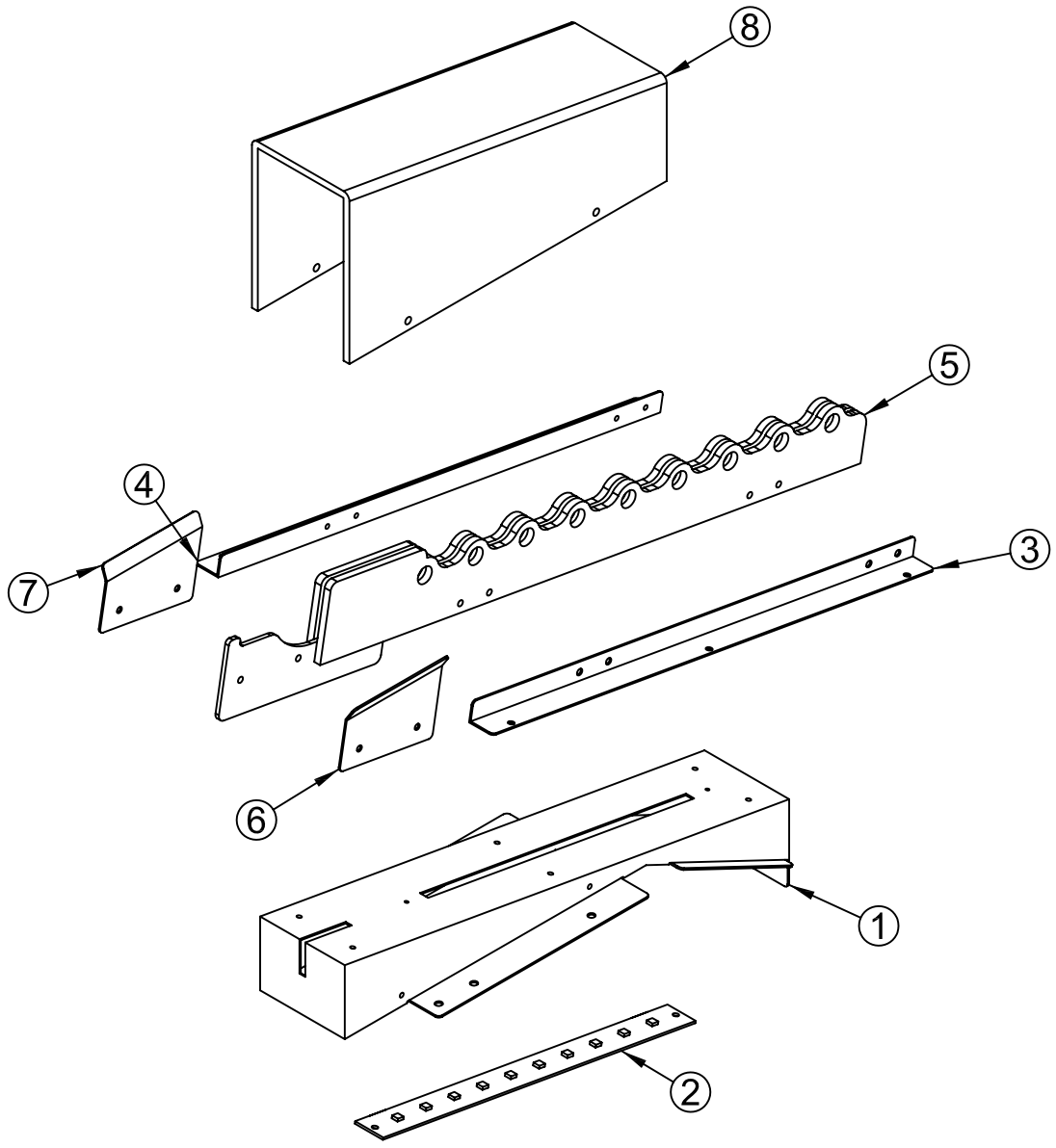

NO.	CODE NO.	QUANTITY	PART NAME	SPEC.
1	MCRC0MEP022	1	SLOPE BOTTOM BODY	SPCC-1.2t
2	ACUC0PCB004	1	SIDE LIGHT R.G,B BOARD	-
3	MCRC0MEP023	1	SLOPE FIXED BKT-A	SPCC-2.0t
4	MCRC0MEP024	1	SLOPE FIXED BKT-B	SPCC-2.0t
5	MCRC0ACR003	1	SLOPE BODY ACRYL BONDING Ass'y	-
6	MCRC0MEP025	1	COIN GUIDE BKT B	SUS304-1.2t
7	MCRC0MEP026	1	COIN GUIDE BKT B_mir	SUS304-1.2t
8	MCRC0ACR004	1	SLOPE COVER ACRYL	CLEAR ACRYL-5.0t

10-15.ASSEMBLING COIN CHECK Ass'y

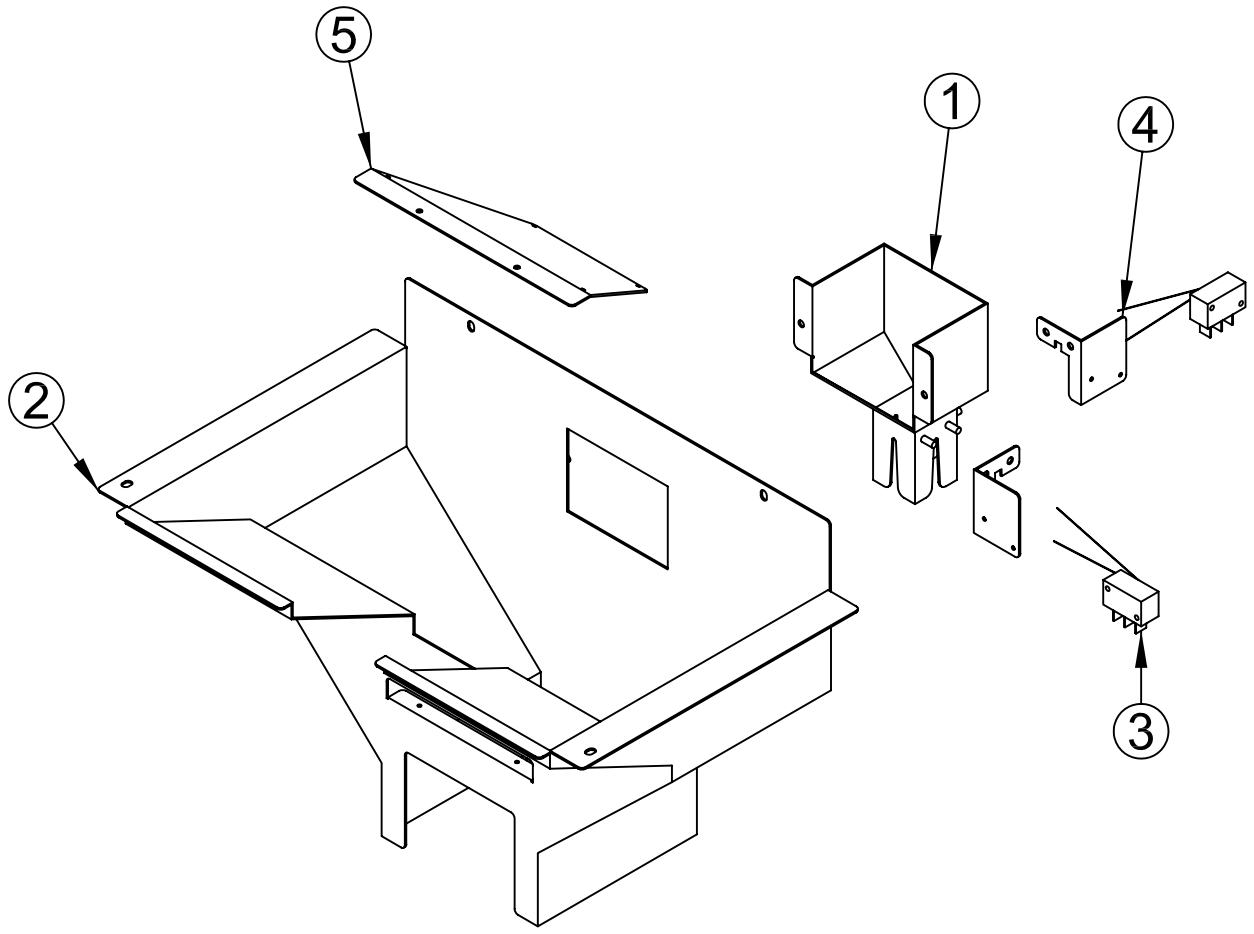

NO.	CODE NO.	QUANTITY	PART NAME	SPEC.
1	MCRC0MEP027	1	COIN CHECK	SPCC-1.2t
2	MCRC0MEP028	1	COIN GUIDE BASKET COVER	SPCC-1.2t
3	MELE0MIC002	2	MICRO SWITCH	CNR-05H03 (ZIPPY)
4	MCRC0MEP029	2	COIN CHECK MICRO SW BKT	SPCC-1.2t
5	MCRC0MEP030	1	COIN LAMP COVER	SUS304-1.2t

10-16.ASSEMBLING SIDE LED LIGHT BKT Ass'y

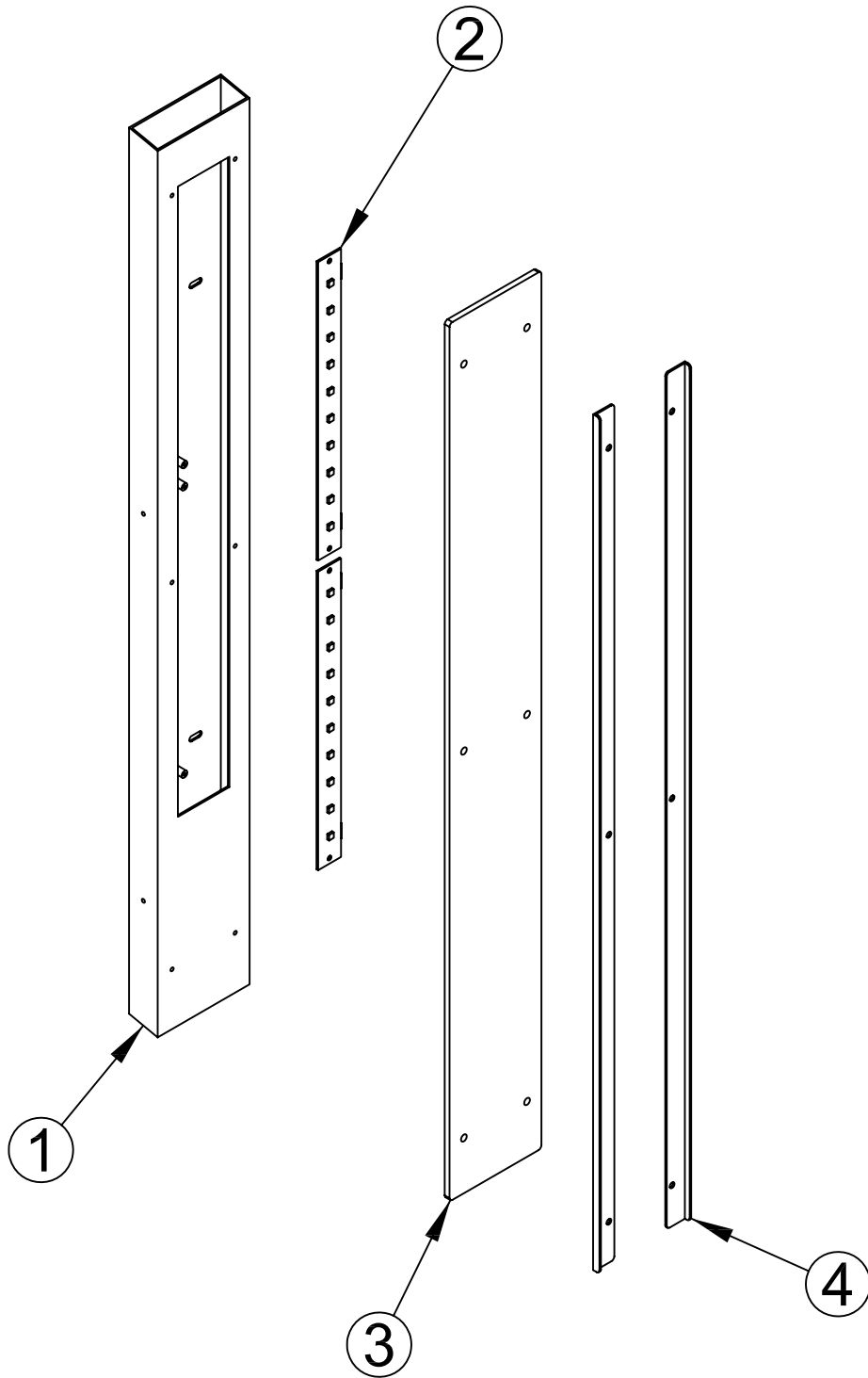

NO.	CODE NO.	QUANTITY	PART NAME	SPEC.
1	MCRC0MEP031	1	SIDE BKT	SPCC-1.6t
2	ACUC0PCB004	2	SIDE LIGHT R,G,B BOARD	-
3	MCRC0ACR005	1	SIDE LIGHTING ACRYL	WHITE LIGHT ACRYL-5.0t
4	MCRC0MEP032	2	SIDE LIGHT ACRYL FIX BKT	SPCC-1.6t

10-17.ASSEMBLING SIDE LED LIGHT BKT Ass'y_mir

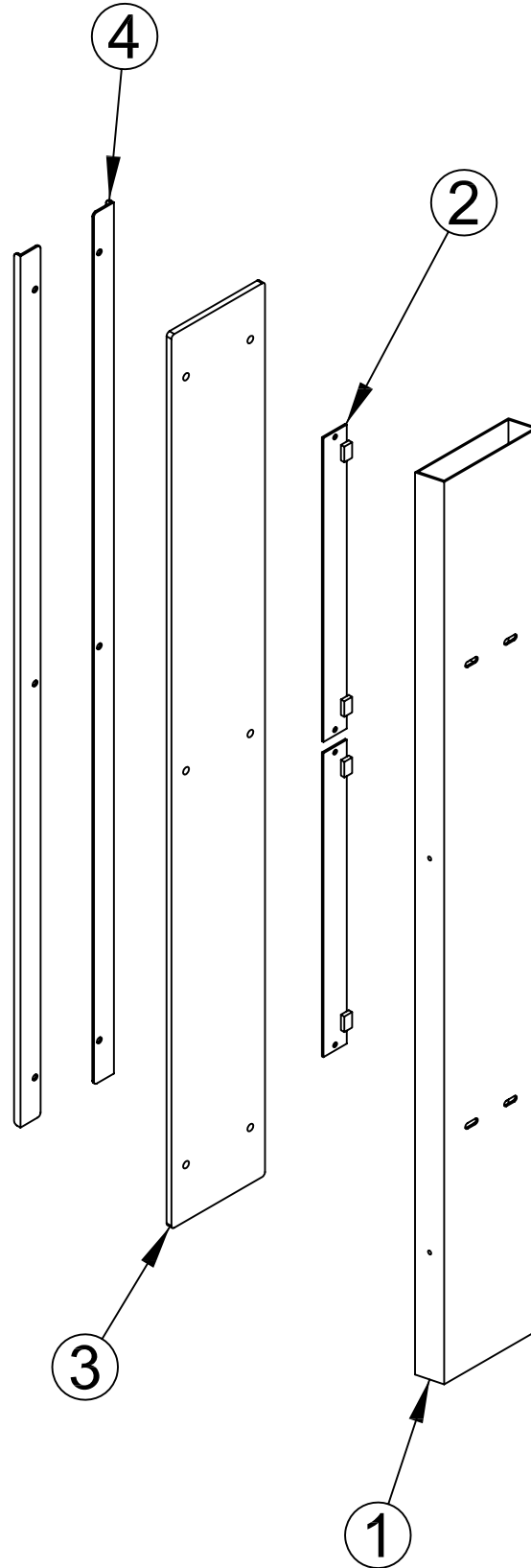

NO.	CODE NO.	QUANTITY	PART NAME	SPEC.
1	MCRC0MEP033	1	SIDE BKT_mir	SPCC-1.6t
2	ACUC0PCB004	2	SIDE LIGHT R,G,B BOARD	-
3	MCRC0ACR005	1	SIDE LIGHTING ACRYL	WHITE LIGHT ACRYL-5.0t
4	MCRC0MEP032	2	SIDE LIGHT ACRYL FIX BKT	SPCC-1.6t

10-18.ASSEMBLING SIDE TOP LED LIGHT BKT Ass'y

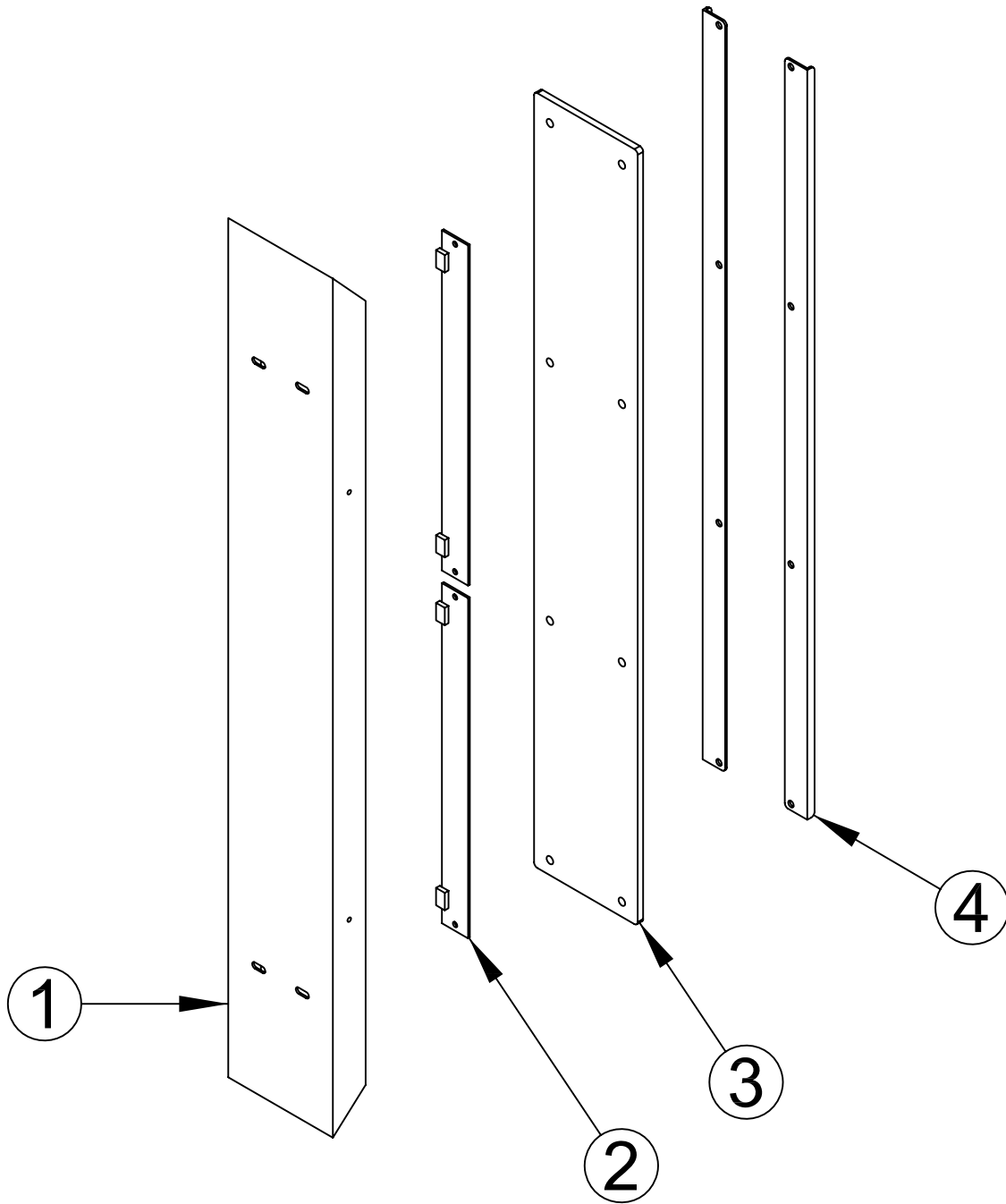

NO.	CODE NO.	QUANTITY	PART NAME	SPEC.
1	MCRC0MEP034	1	TOP BKT	SPCC-1.6t
2	ACUC0PCB004	2	SIDE LIGHT R,G,B BOARD	-
3	MCRC0ACR006	1	UPPER LIGHTING ACRYL	WHITE LIGHT ACRYL-5.0t
4	MCRC0MEP035	2	UPPER LIGHT ACRYL FIX BKT	SPCC-1.6t

10-19.ASSEMBLING SIDE TOP LED LIGHT BKT Ass'y_mir

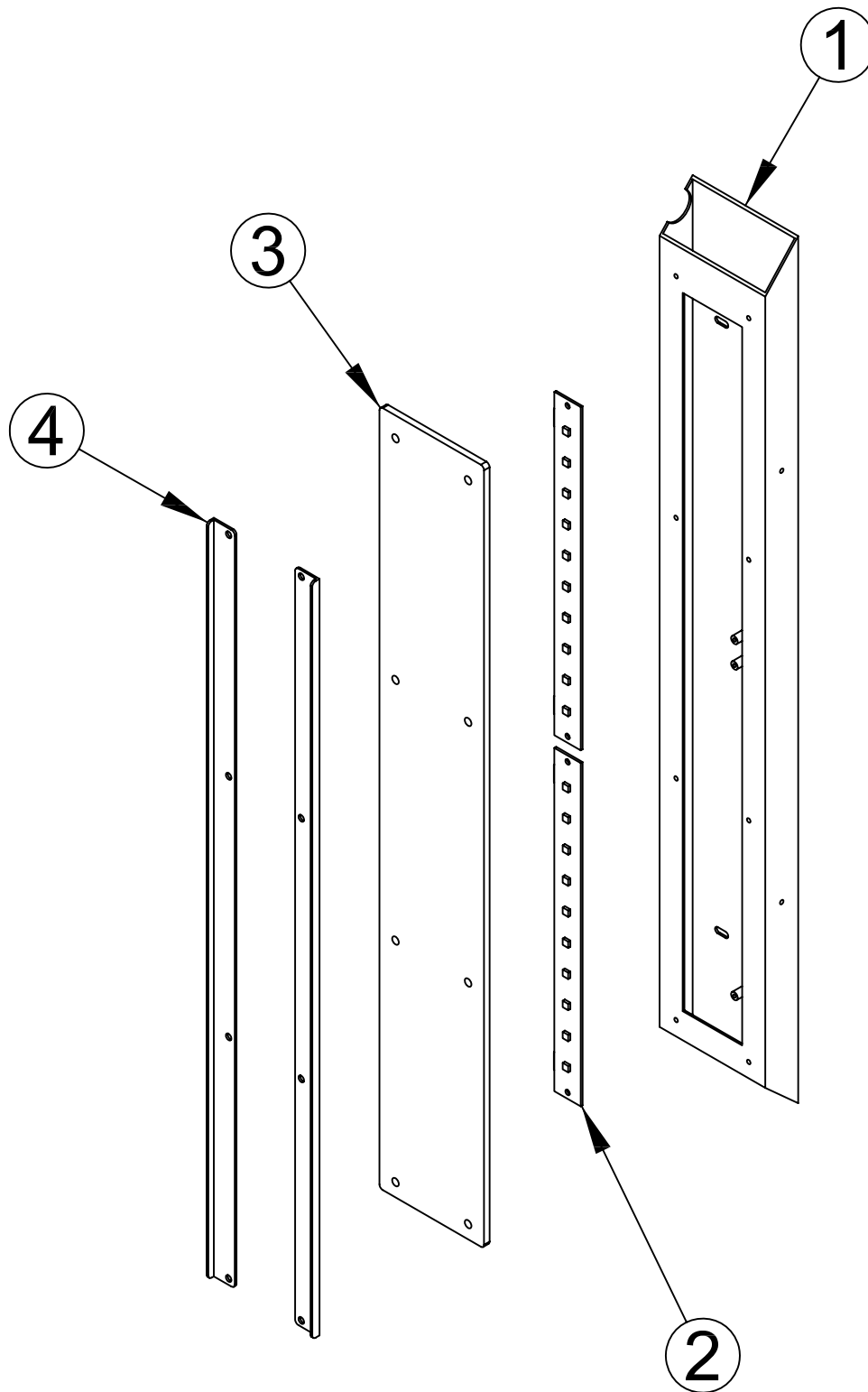

NO.	CODE NO.	QUANTITY	PART NAME	SPEC.
1	MCR00MEP036	1	TOP BKT_mir	SPCC-1.6t
2	ACUC0PCB004	2	SIDE LIGHT R,G,B BOARD	-
3	MCR00ACR006	1	UPPER LIGHTING ACRYL	WHITE LIGHT ACRYL-5.0t
4	MCR00MEP035	2	UPPER LIGHT ACRYL FIX BKT	SPCC-1.6t

10-20.ASSEMBLING E/L TAIL PULLEY BEARING Ass'y

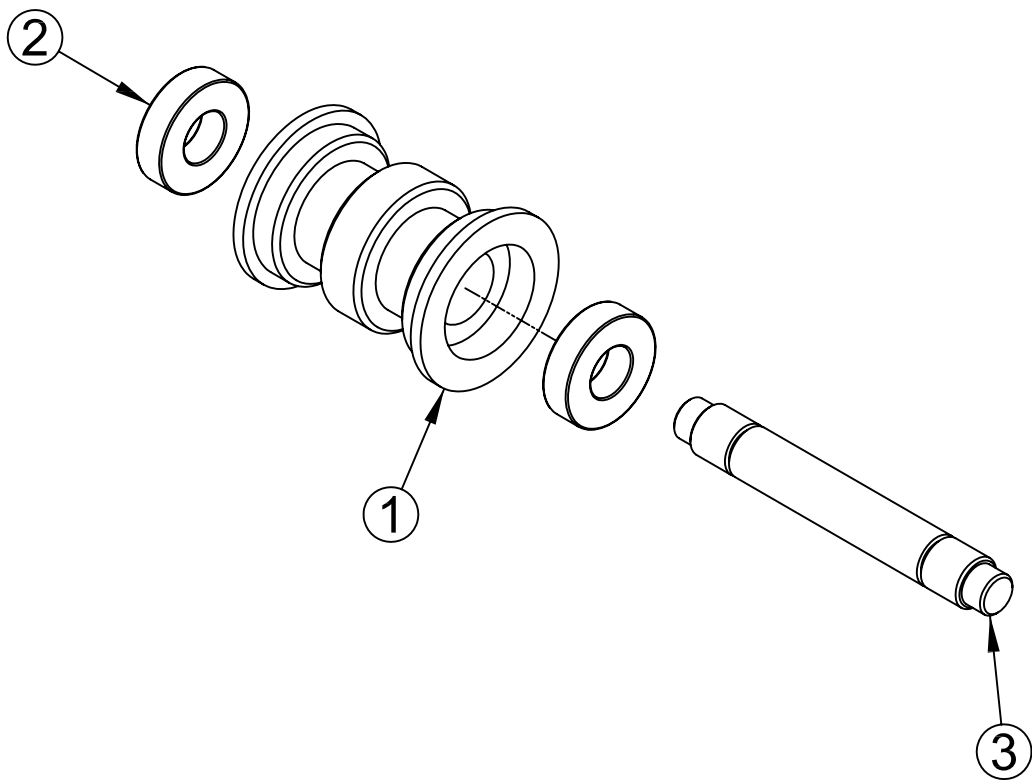

NO.	CODE NO.	QUANTITY	PART NAME	SPEC.
1	MCRC0PRO001	1	E/L TAIL PULLEY	SS41
2	MZZZ0BEA007	2	BEARING	6900 ZZ
3	MCRC0PRO002	1	TAIL SHAFT	SS41

10-21.ASSEMBLING ELEVATOR Ass'y

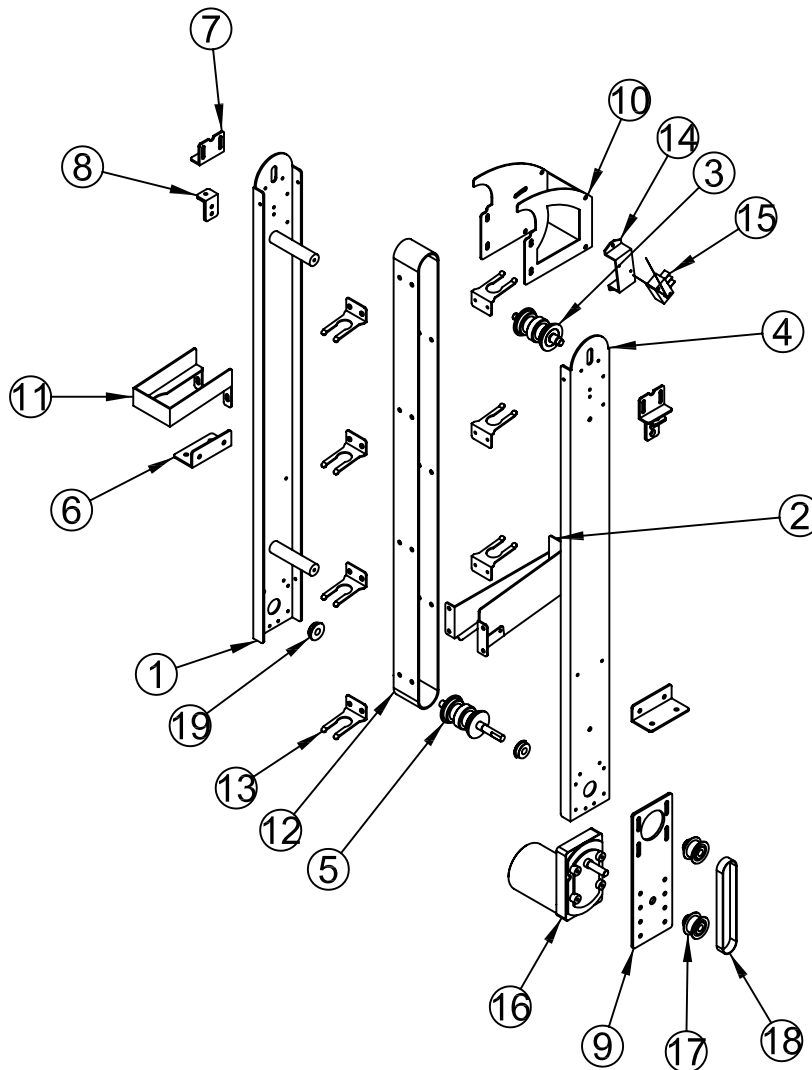

NO.	CODE NO.	QUANTITY	PART NAME	SPEC.
1	MCRC0MEP037	1	E/L BODY-A WELD Ass'y	-
2	MCRC0MEP038	1	E/L CHUTE-B WELD Ass'y	-
3	MCRC0MEP079	1	E/L TAIL PULLEY BEARING Ass'y	10-20 (p.31)
4	MCRC0MEP039	1	E/L BODY-B	SPCC-2.0t
5	MCRC0PRO003	1	E/L HEAD PULLEY	SS41
6	MCRC0MEP040	2	E/L FIXED BKT	SPCC-2.0t
7	MCRC0MEP041	2	TENSION BKT-A	SPCC-2.0t
8	MCRC0MEP042	2	TENSION BKT-B	SPCC-3.0t
9	MCRC0MEP043	1	MOTOR BKT	SPCC-3.0t
10	MCRC0MEP044	1	S/W BKT COVER	SPCC-1.6t
11	MCRC0MEP045	1	ELEVATOR SLOPE	SPCC-1.6t
12	MCUC0BEL001	1	CONVEYOR BELT	BLACK-2.0t
13	MCRC0MEP046	7	BALL ATTACHMENT	SUS304-1.5t
14	MCRC0MEP047	1	BALL TOUCH S/W BKT	SPCC-1.6t
15	MELE0MIC002	1	MICRO SWITCH	CNR-05H03 (ZIPPY)
16	MCUC0MOT002	1	MOTOR	KGY-055-6080D1
17	MCRC0PRO004	2	PULLEY (13XL 037 28F)	AL
18	MWET0BEL002	1	TIMING BELT	110XL 037
19	MTIM0BEA004	2	BEARING	F698 ZZ

10-22.ASSEMBLING PENDULUM Ass'y

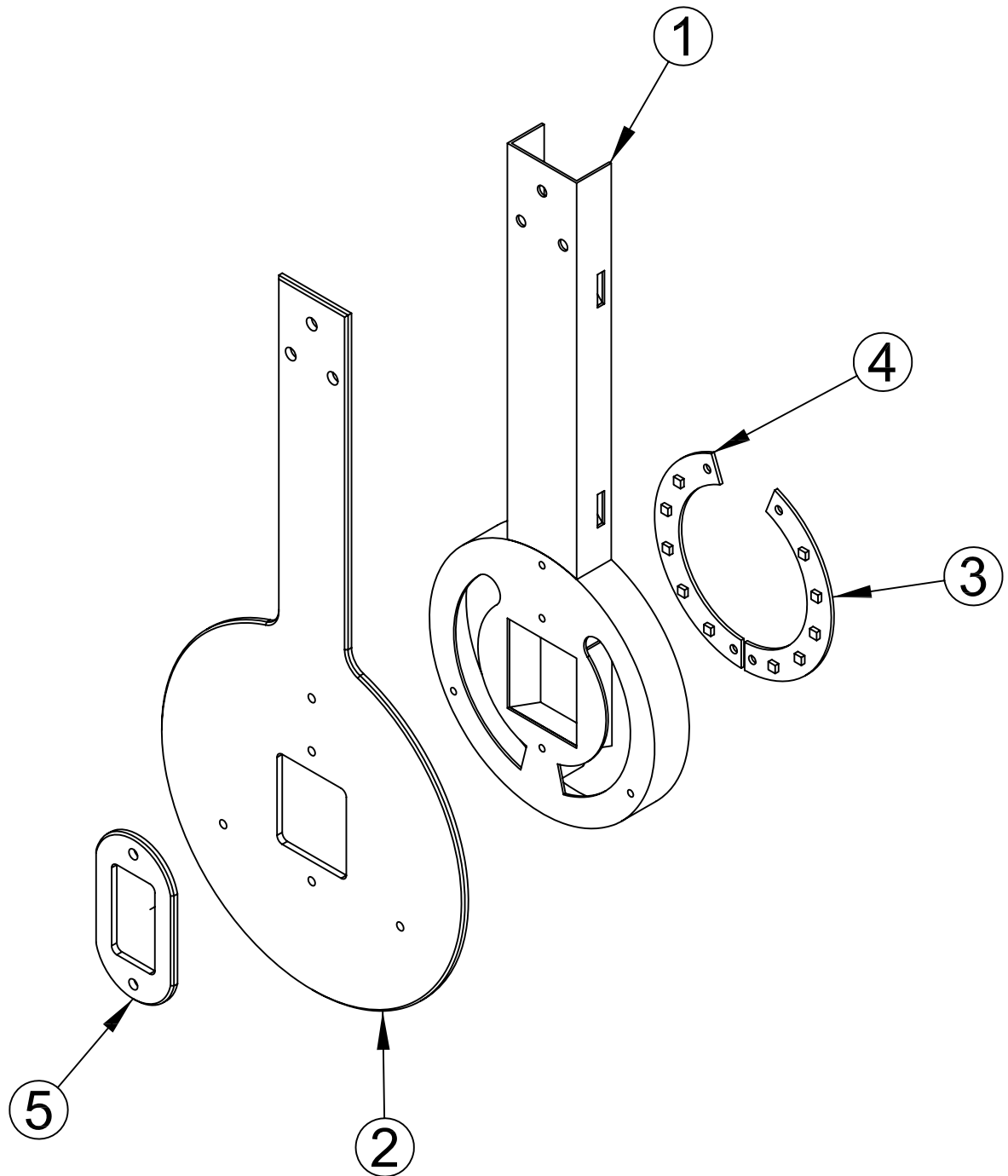

NO.	CODE NO.	QUANTITY	PART NAME	SPEC.
1	MCRC0MEP048	1	PENDULUM WELD Ass'y	-
2	MCRC0SHE018	1	PENDULUM ACRYL	CLEAR PC-3.0t
3	ACU20PCB004	1	PENDULUM R LED BOARD	-
4	ACU20PCB008	1	PENDULUM L LED BOARD	-
5	MCRC0SHE016	1	GUIDE ACRYL 25X45	CLEAR PC-3.0t

10-23.ASSEMBLING PENDULUM MOTOR Ass'y (CEC)

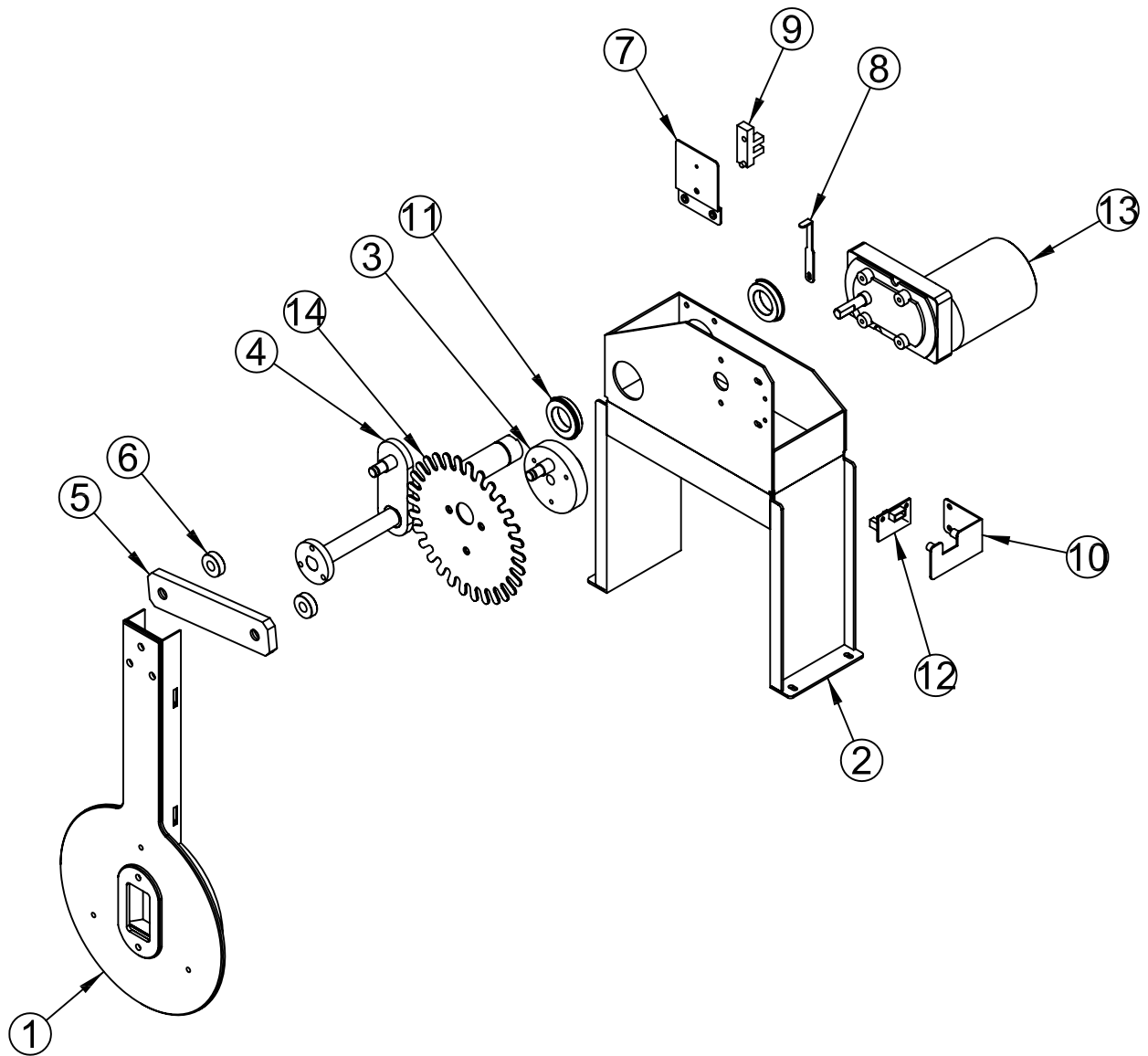

NO.	CODE NO.	QUANTITY	PART NAME	SPEC.
1	MCRC0MEP080	1	PENDULUM Ass'y	10-22 (p.33)
2	MCRC0MEP073	1	PENDULUM BODY WELD Ass'y (CEC)	-
3	MCRC0PRO014	1	MOTOR SHAFT WELD Ass'y (CEC)	-
4	MCRC0PRO015	1	CAM SHAFT WELD Ass'y (CEC)	-
5	MCRC0PRO005	1	LINK PLATE	SM45C
6	MZZZ0BEA032	2	BEARING	698 ZZ
7	MCRC0MEP049	1	SHAFT SENSOR BKT-B	SPCC-1.2t
8	MCRC0MEP050	1	SHAFT SENSOR BKT-A	SUS304-1.2t
9	MELE0PHO007	1	PHOTO SENSOR	LG-217L3
10	MCRC0MEP074	1	PENDULUM SENSOR BKT (CEC)	SPCC-1.2t
11	MCU20BEA001	2	BEARING (NR)	6804 ZZ (NR)
12	ASPS0PCB001	1	PHOTO SENSOR 1B BOARD	-
13	MSPS0MOT001	1	MOTOR	KGY-100-K6DG15N1
14	MCRC0MEP051	1	PENDULUM SENSOR VANE-A	SPCC-1.6t

10-24.ASSEMBLING WHEEL MOTOR Ass'y

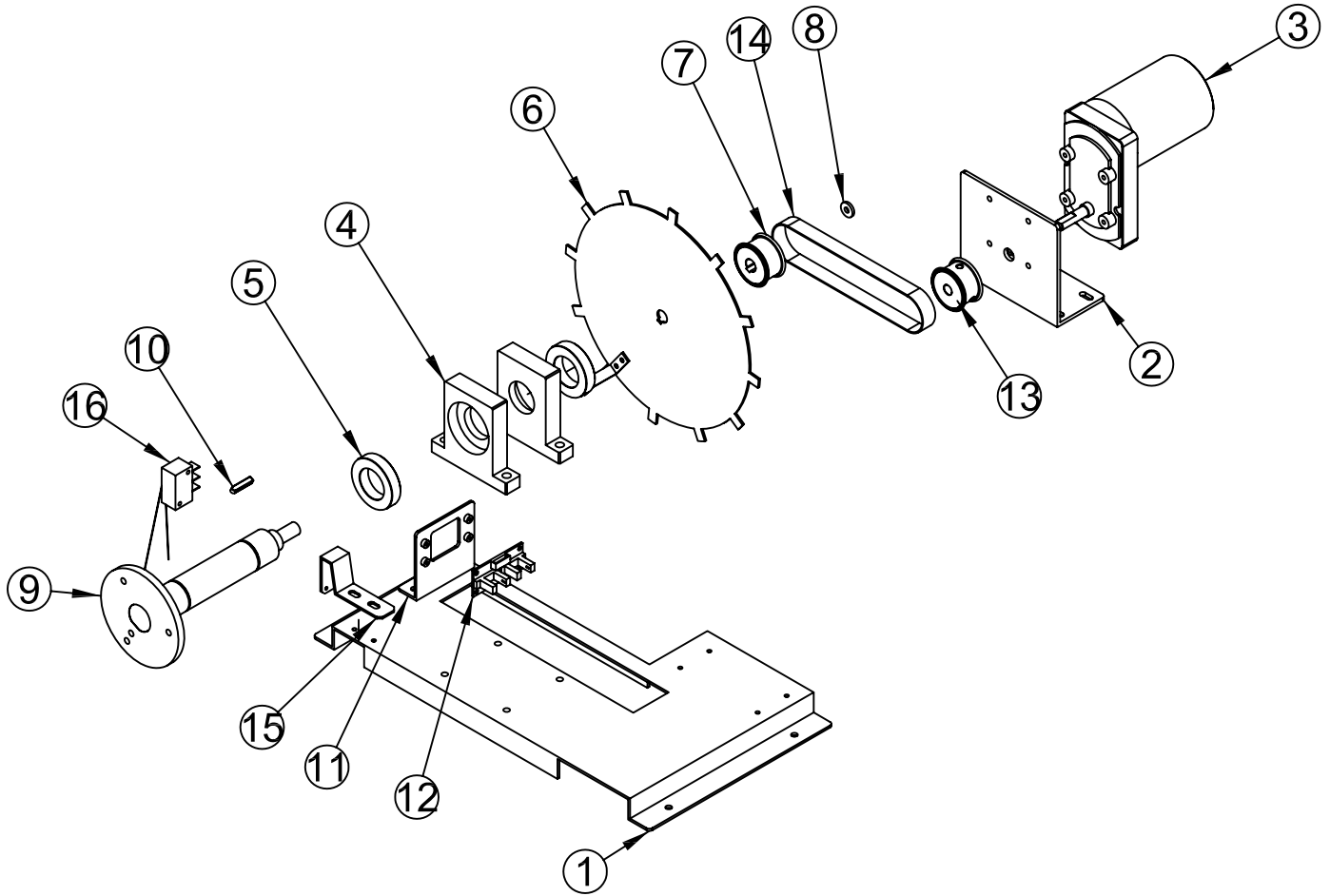

NO.	CODE NO.	QUANTITY	PART NAME	SPEC.
1	MCRC0MEP052	1	WHEEL MOTOR BASE WELD Ass'y	-
2	MCRC0MEP053	1	WHEEL MOTOR BKT	SPCC-3.0t
3	MCUC0MOT001	1	MOTOR	KGY-360-6080D1 (SSF-01)
4	MCRC0PRO006	2	R-BEARING HOUSING	SS41
5	MZZZ0BEA044	2	BEARING	6905 ZZ
6	MCRC0MEP054	1	SENSOR VANE WELD Ass'y	-
7	MCRC0PRO007	1	WHEEL SHAFT PULLEY (LO50-10 33F)	AL
8	MCRC0PRO008	1	WASHER	AL
9	MCRC0PRO009	1	R-SHAFT WELD Ass'y	-
10	MCRC0PRO010	1	4X4X20L KEY	SM45C
11	MCRC0MEP055	1	SENSOR BKT	SPCC-2.0t
12	AALA0PCB010	1	PHOTO SENSOR BOARD	-
13	MCRC0PRO011	1	WHEEL MOTOR PULLEY (LO50-10 33F)	AL
14	MZZZ0BEL008	1	TIMING BELT	135 L 050
15	MCRC0MEP056	1	MICRO S/W BKT	SPCC-1.6t
16	MELE0MIC002	1	MICRO SWITCH	CNR-05H03 (ZIPPY)

10-25.ASSEMBLING ROTARY WHEEL Ass'y

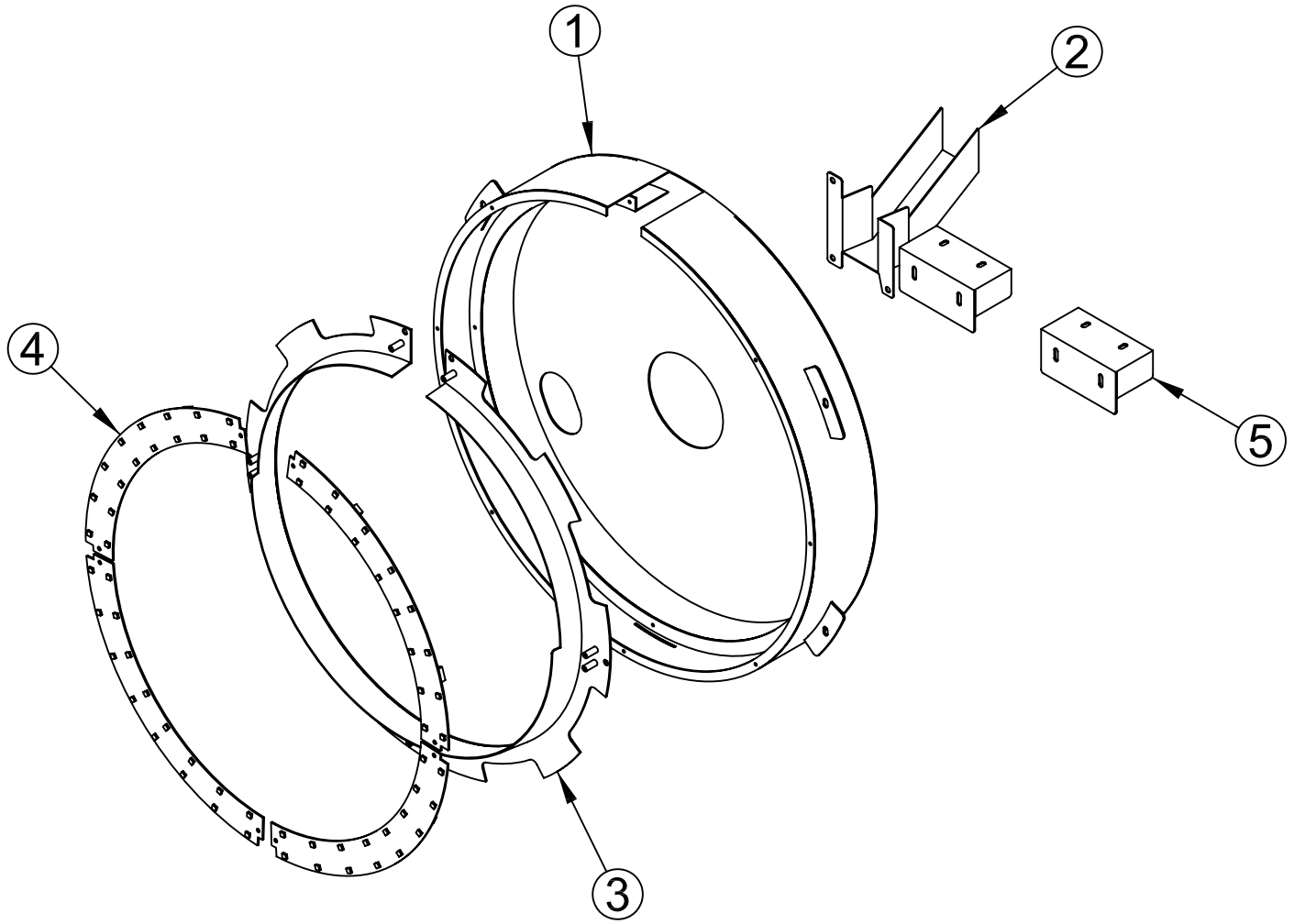

NO.	CODE NO.	QUANTITY	PART NAME	SPEC.
1	MCRC0MEP057	1	ROTARY WHEEL COVER WELD Ass'y	-
2	MCRC0MEP058	1	SLOPE-1	SPCC-1.2t
3	MCRC0MEP059	1	PCB BKT WELD Ass'y	-
4	ACUC0PCB008	4	BONUS LIGHT BOARD	-
5	MCRC0MEP060	2	ROTARY BODY-A BOTTOM SUPPORT	SPCC-1.6t

10-26.ASSEMBLING BONUS GAME PLATE Ass'y

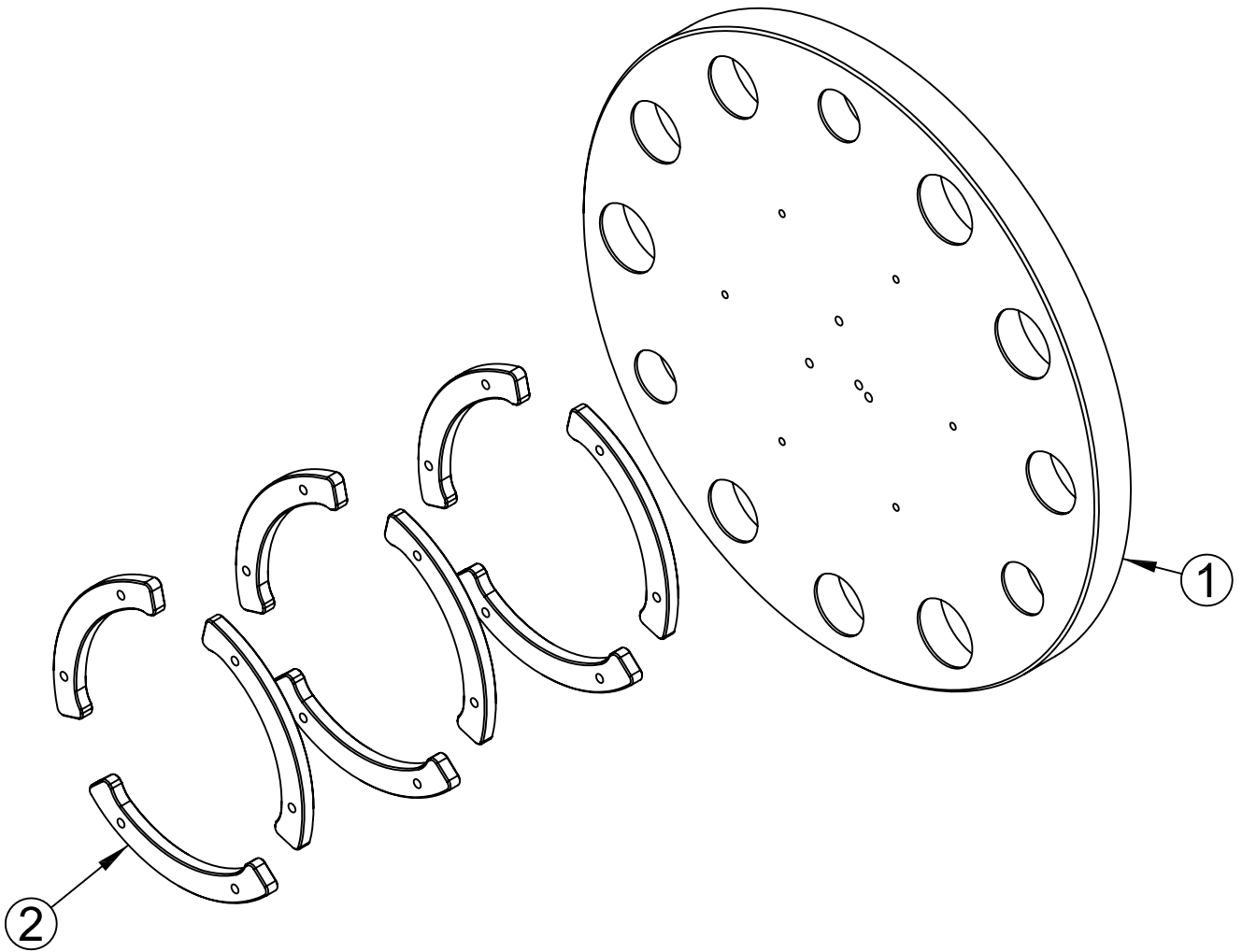

NO.	CODE NO.	QUANTITY	PART NAME	SPEC.
1	MCRC0WOO002	1	BONUS GAME PLATE	MDF-30.0t
2	MCRC0ACR007	9	BALL GUIDE ACRYL-C	CLEAR ACRYL-10.0t

10-27.ASSEMBLING CASE Ass'y (CEC)

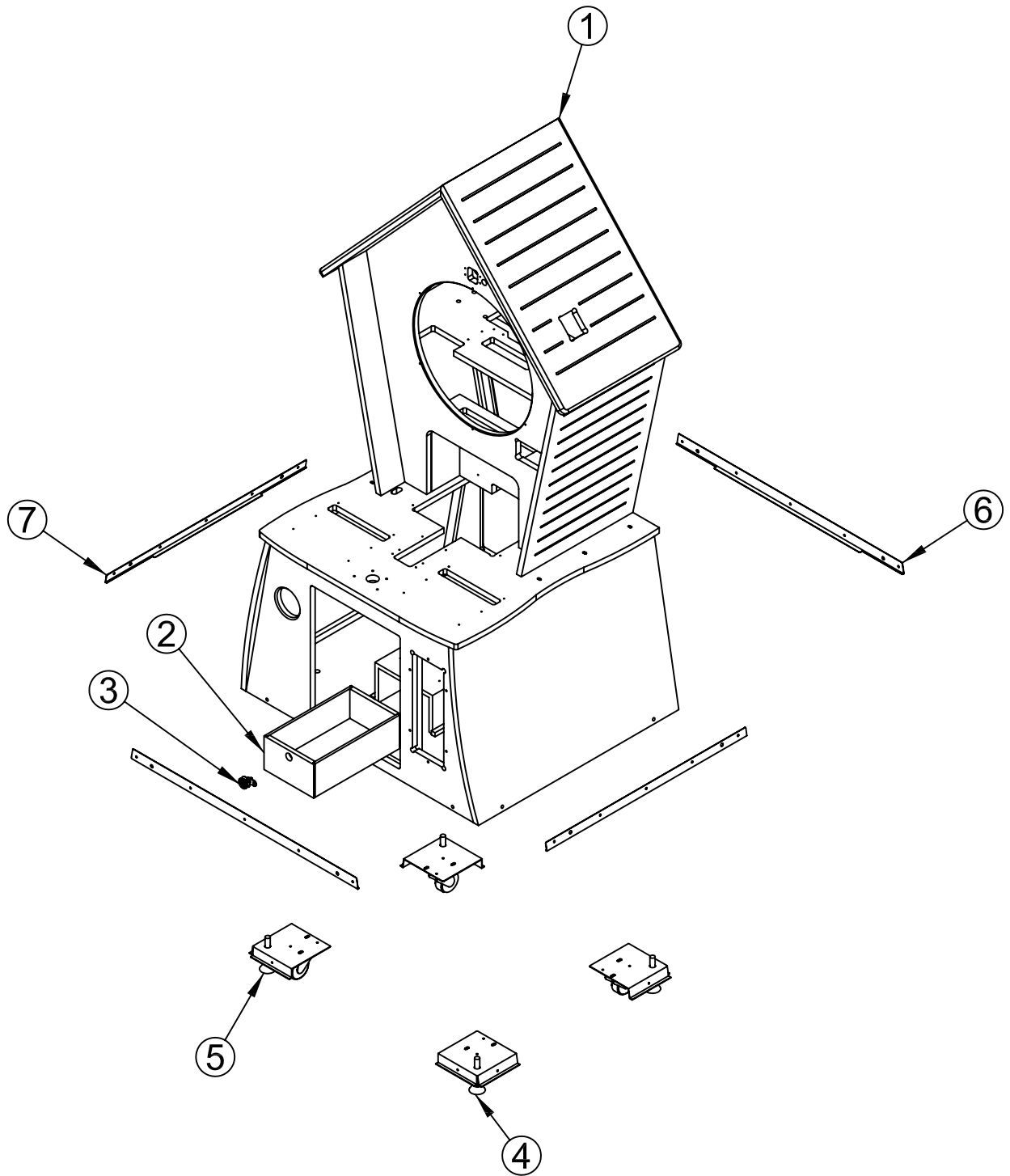

NO.	CODE NO.	QUANTITY	PART NAME	SPEC.
1	-	1	MAIN CASE (CEC)	-
2	MCRC0W00003	1	CASH BOX	MDF-9.0t & 15.0t
3	MZZZ0KEY013	1	KEY Ass'y (6001)	6001
4	MCRC0W00015	2	CASTER Ass'y	-
5	MCRC0W00016	2	CASTER Ass'y_mir1	-
6	MCRC0W00017	2	FRONT LOWER CASE COVER BKT (CEC)	SPCC-1.0t
7	MCRC0W00018	2	SIDE LOWER CASE COVER BKT (CEC)	SPCC-1.0t

10-28-1.ASSEMBLING CRAZY CUCKOO ALL FIX Ass'y (CEC)

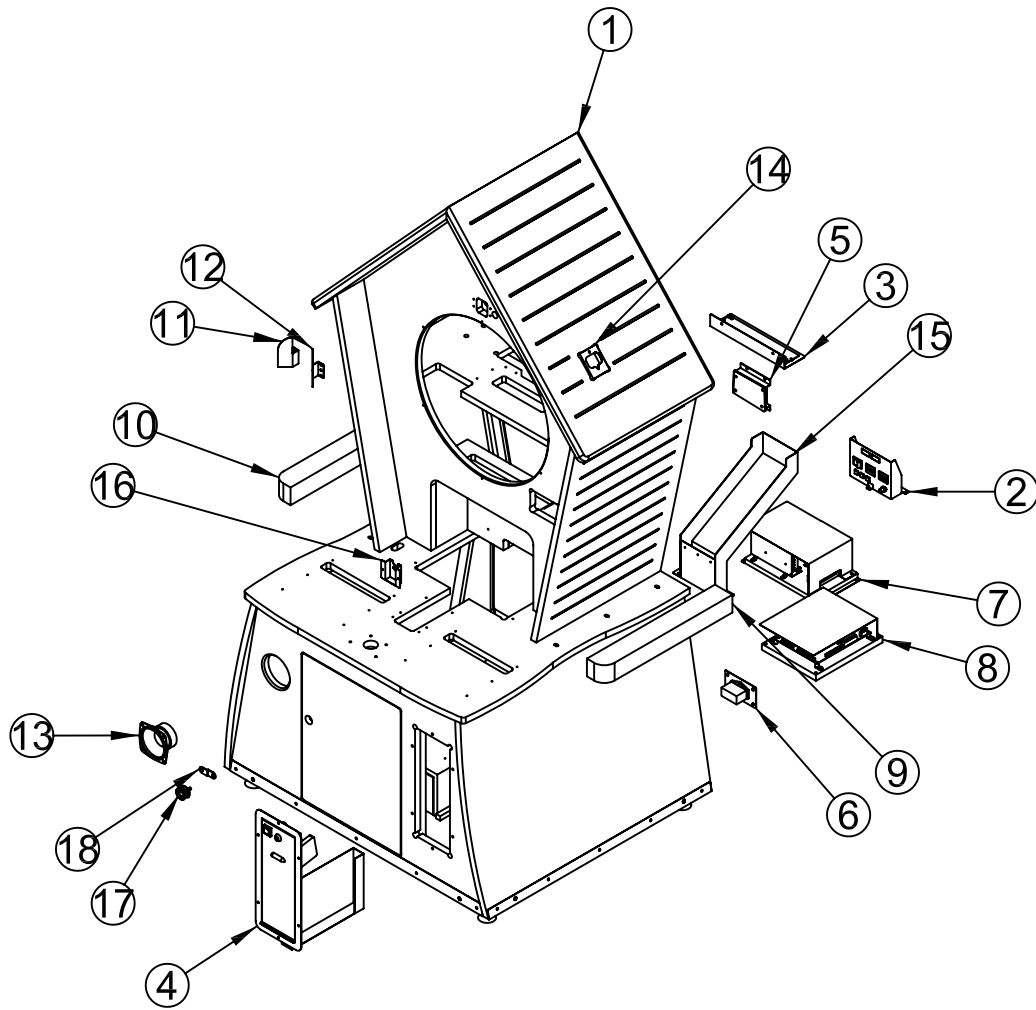

NO.	CODE NO.	QUANTITY	PART NAME	SPEC.
1	MCRC0WOO010	1	CASE Ass'y (CEC)	10-27 (p.38)
2	MCRC0MEP081	1	AC POWER SWITCH Ass'y	10-3 (p.17)
3	MCRC0MEP082	1	PENDULUM TOP LED Ass'y	10-11 (p.23)
4	MCRC0MEP101	1	TICKET BOX Ass'y	10-9 (p.22)
5	MCRC0MEP110	1	TICKET FND Ass'y (CEC)	10-10 (p.23)
6	MCRC0MEP084	1	NOISE FILTER Ass'y	10-6 (p.19)
7	MCRC0MEP106	1	POWER SMPS Ass'y (CEC)	10-5 (p.19)
8	MCRC0MEP107	1	MAIN BOARD Ass'y (CEC)	10-4 (p.18)
9	MCRC0MEP061	1	GARDEN PLATE-A	SPCC-1.2t
10	MCRC0MEP062	1	GARDEN PLATE-A_mlr	SPCC-1.2t
11	MCRC0MEP075	1	CUCKOO DOOR (CEC)	SPCC-1.6t
12	MCRC0MEP076	1	CUCKOO DOOR_mlr (CEC)	SPCC-1.6t
13	MZZZ0SPE004	1	SPEKER	MID 4.5 8Ω 80W
14	MCRC0MEP077	1	BONUS PLATE BKT (CEC)	SPCC-1.2t
15	MCRC0MEP063	1	COIN RETURN CHUTE	SPCC-1.2t
16	MCRC0MEP078	1	PENDULUM CONNECTOR BKT (CEC)	SPCC-1.2t
17	MZZZ0KEY032	1	KEY Ass'y (7001)	7001
18	MCRC0MEP072	1	KEY PLATE (CEC)	SPCC-2.0t

10-28-2.ASSEMBLING CRAZY CUCKOO ALL FIX Ass'y (CEC)

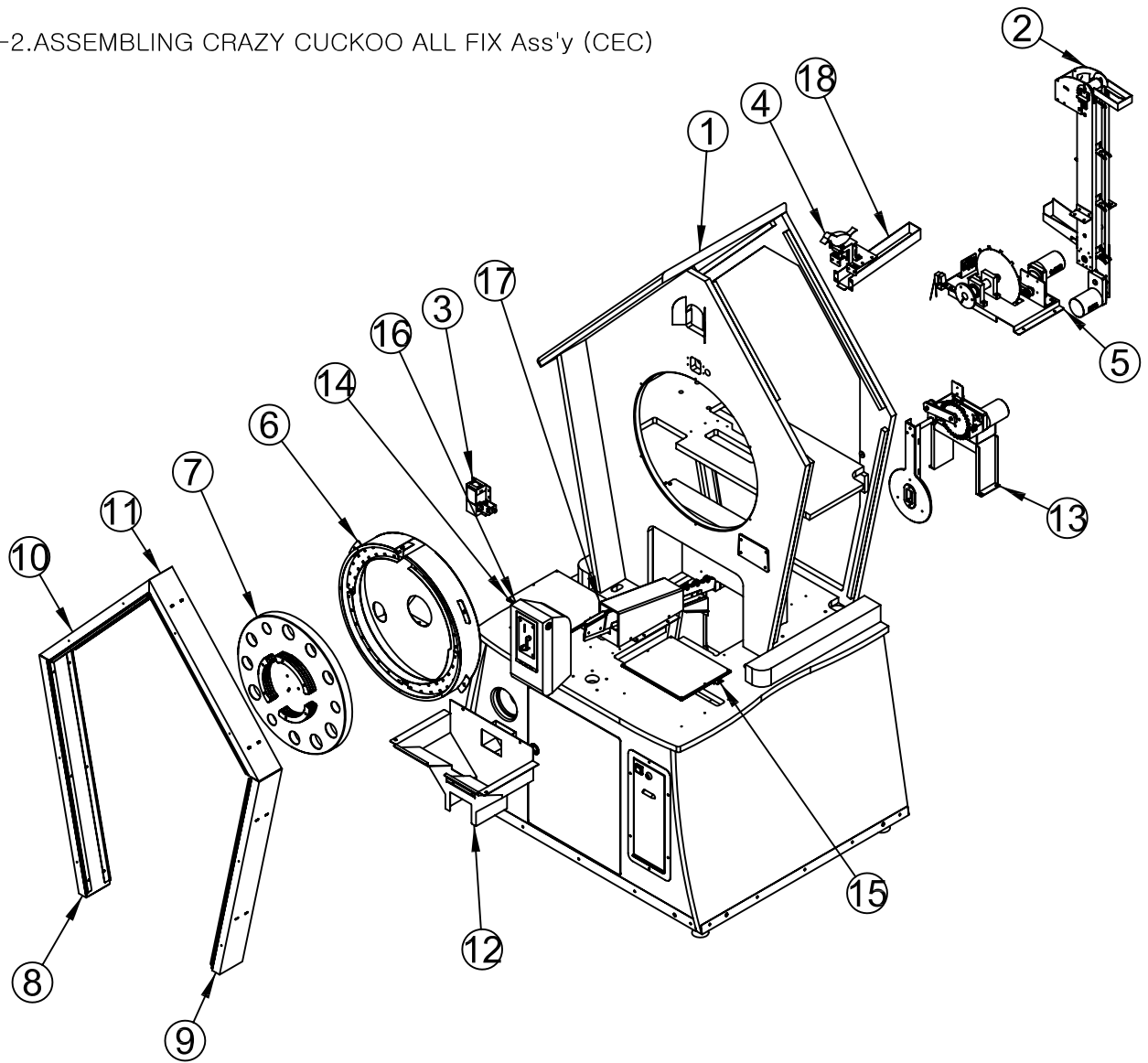

NO.	CODE NO.	QUANTITY	PART NAME	SPEC.
1	MCRC0WOO010	1	CASE Ass'y (CEC)	10-27 (p.38)
2	MCRC0MEP085	1	ELEVATOR Ass'y	10-21 (p.32)
3	MCRC0MEP086	1	BALL SLOPE Ass'y	10-7 (p.20)
4	MCRC0MEP087	1	CUCKOO HOUSE Ass'y	10-8 (p.21)
5	MCRC0MEP088	1	WHEEL MOTOR Ass'y	10-24 (p.35)
6	MCRC0MEP089	1	ROTARY WHEEL Ass'y	10-25 (p.36)
7	MCRC0MEP090	1	BONUS GAME-PLATE Ass'y	10-26 (p.37)
8	MCRC0MEP091	1	SIDE LED LIGHT BKT Ass'y	10-16 (p.27)
9	MCRC0MEP092	1	SIDE LED LIGHT BKT Ass'y_mir	10-17 (p.28)
10	MCRC0MEP093	1	SIDE TOP LED LIGHT BKT Ass'y	10-18 (p.29)
11	MCRC0MEP094	1	SIDE TOP LED LIGHT BKT Ass'y_mlr	10-19 (p.30)
12	MCRC0MEP095	1	COIN CHECK Ass'y	10-15 (p.26)
13	MCRC0MEP108	1	PENDULUM MOTOR Ass'y (CEC)	10-23 (p.34)
14	MCRC0MEP096	1	FRONT DISPLAY ACRYL-L Ass'y	10-12 (p.24)
15	MCRC0MEP097	1	FRONT DISPLAY ACRYL-R Ass'y	10-13 (p.24)
16	MCRC0MEP098	1	COIN BOX Ass'y	10-1 (p.15)
17	MCRC0MEP099	1	COIN SLOPE Ass'y	10-14 (p.25)
18	MCRC0MEP064	1	SLOPE-3	SPCC-1.2t

10-28-3.ASSEMBLING CRAZY CUCKOO ALL FIX Ass'y (CEC)

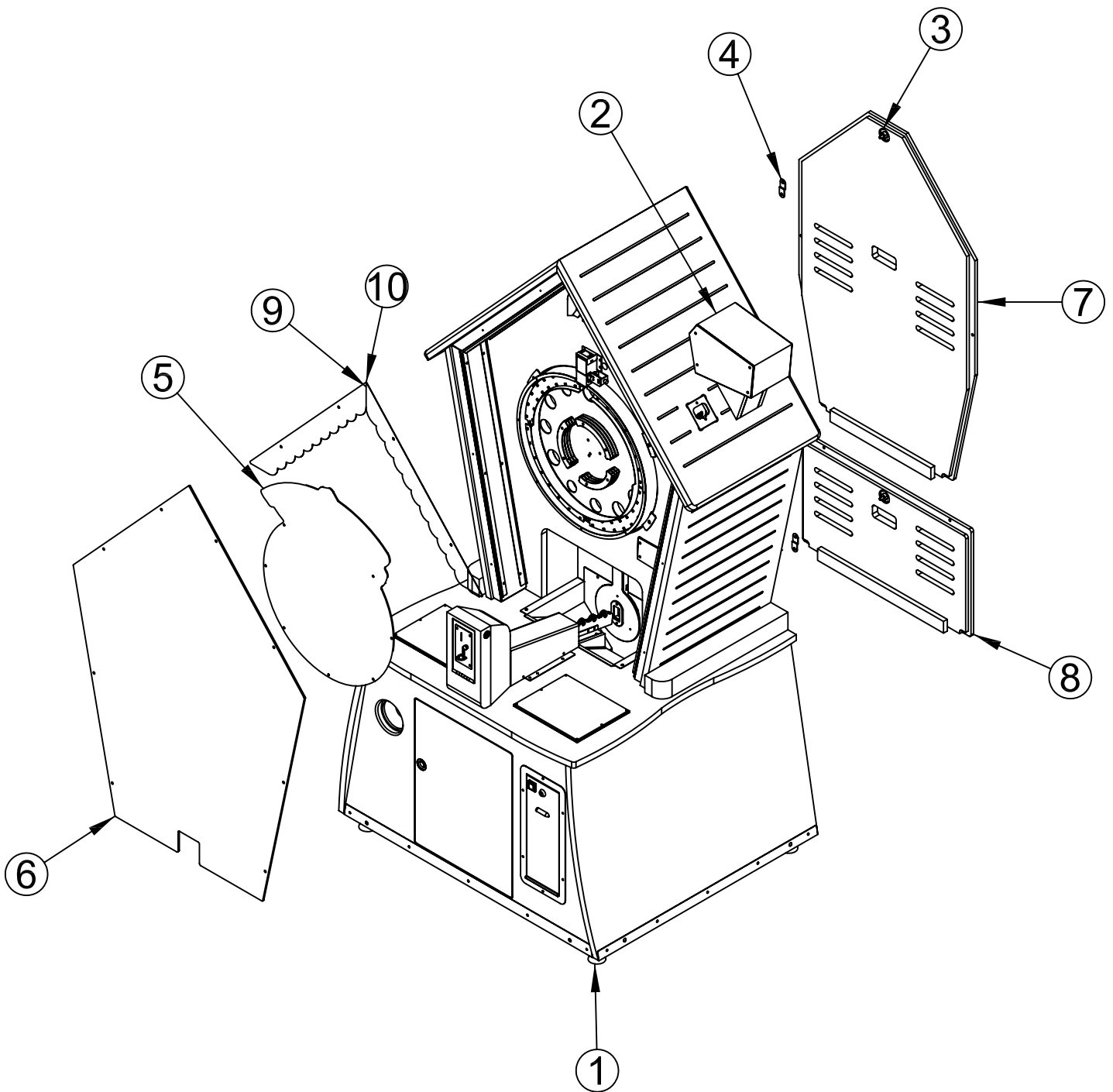

NO.	CODE NO.	QUANTITY	PART NAME	SPEC.
1	MCRC0WOO010	1	CASE Ass'y (CEC)	10-27 (p.38)
2	MCRC0MEP100	1	BONUS Ass'y	10-2 (p.16)
3	MZZZ0KEY032	2	KEY Ass'y (7001)	7001
4	MCRC0MEP072	2	KEY PLATE (CEC)	SPCC-2.0t
5	MCRC0SHE019	1	WHEEL COVER ACRYL	CLEAR ACRYL-3.0t
6	MCRC0ACR009	1	FRONT DOOR ACRYL	CLEAR ACRYL-5.0t
7	MCRC0WOO011	1	REAR UPPER DOOR (CEC)	MDF-20.0t
8	MCRC0WOO012	1	REAR LOWER DOOR (CEC)	MDF-20.0t
9	MCRC0SHE021	1	TOP DECO PET L	PET-1.0t
10	MCRC0SHE022	1	TOP DECO PET L_mir	PET-1.0t

CRAZY CUCKOO SHEET (CEC TYPE)











2012. 12. 19		CRAZY CUCKOO SHEET (CEC TYPE)			
IMAGE	NAME	QUANTITY	MATERIAL	CDDE NO.	
1		FRINT DOOR SHEET	1SET	SHEET Silk screen	MRCOSHE001
2		COIN GUIDE BASKET COVER A SHEET	1SET	SHEET Silk screen	MRCOSHE002
3		COIN GUIDE BASKET COVER B SHEET	1SET	SHEET Silk screen	MRCOSHE003
4		FRONT UPPER SHEET	1SET	SHEET Silk screen	MRCOSHE004
5		CUCKOO DOOR 01 SHEET	1SET	SHEET Silk screen	MRCOSHE005
6		GARDEN PLATE A L SHEET	1SET	SHEET Silk screen	MRCOSHE006
7		GARDEN PLATE A R SHEET	1SET	SHEET Silk screen	MRCOSHE007
8		GARDEN PLATE B L,R SHEET	2SET	SHEET Silk screen	MRCOSHE008
9		SEGA LOGO CUCKOO SHEET	1SET	SHEET Silk screen	MRCOSHE009
10		RECYCLE MARK SHEET	1SET	SHEET Silk screen	MRCOSHE010
11		TICKETS SHEET	1SET	SHEET Silk screen	MRCOSHE011
12		HOW TO PLAY L SHEET	1SET	BACK LIGHTING	MRCOSHE012
13		HOW TO PLAY R SHEET	1SET	BACK LIGHTING	MRCOSHE013
14		TICKET OWED ACRYL SHEET	1SET	ACRYL Silk screen	MRCOSHE014
15		GUIDE ACRYL 20X45 SHEET	1SET	ACRYL Silk screen	MRCOSHE015
16		GUIDE ACRYL 25X45 SHEET	1SET	ACRYL Silk screen	MRCOSHE016
17		GUIDE ACRYL 30X45 SHEET	1SET	ACRYL Silk screen	MRCOSHE017
18		PENDULUM ACRYL SHEET	1SET	ACRYL Silk screen	MRCOSHE018
19		WHEEL COVER ACRYL SHEET	1SET	ACRYL Silk screen	MRCOSHE019
20		BONUS ACRYL SHEET	1SET	ACRYL Silk screen	MRCOSHE020
21		TOP DECO PET L	1SET	ACRYL Silk screen	MRCOSHE021
22		TOP DECO PET R	1SET	ACRYL Silk screen	MRCOSHE022

CRAZY CUCKOO SHEET (CEC TYPE)



2012. 12. 19

CRAZY CUCKOO SHEET (CEC TYPE)

23		CUCKOO DOOR 02 L SHEET	1SET	SHEET Silk screen	MRCOSHE023
24		CUCKOO DOOR 02 R SHEET	1SET	SHEET Silk screen	MRCOSHE024
25		SIDE LOW L SHEET	1SET	SHEET Silk screen	MRCOSHE025
26		SIDE LOW R SHEET	1SET	SHEET Silk screen	MRCOSHE026
27		FRONT LOWER UPPER SHEET	1SET	SHEET Silk screen	MRCOSHE027
28		FRONT LOWER LOWER L SHEET	1SET	SHEET Silk screen	MRCOSHE028
29		FRONT LOWER LOWER R SHEET	1SET	SHEET Silk screen	MRCOSHE029
30		BONUS GAME PLATE CEC SHEET	1SET	SHEET Silk screen	MRCOSHE031

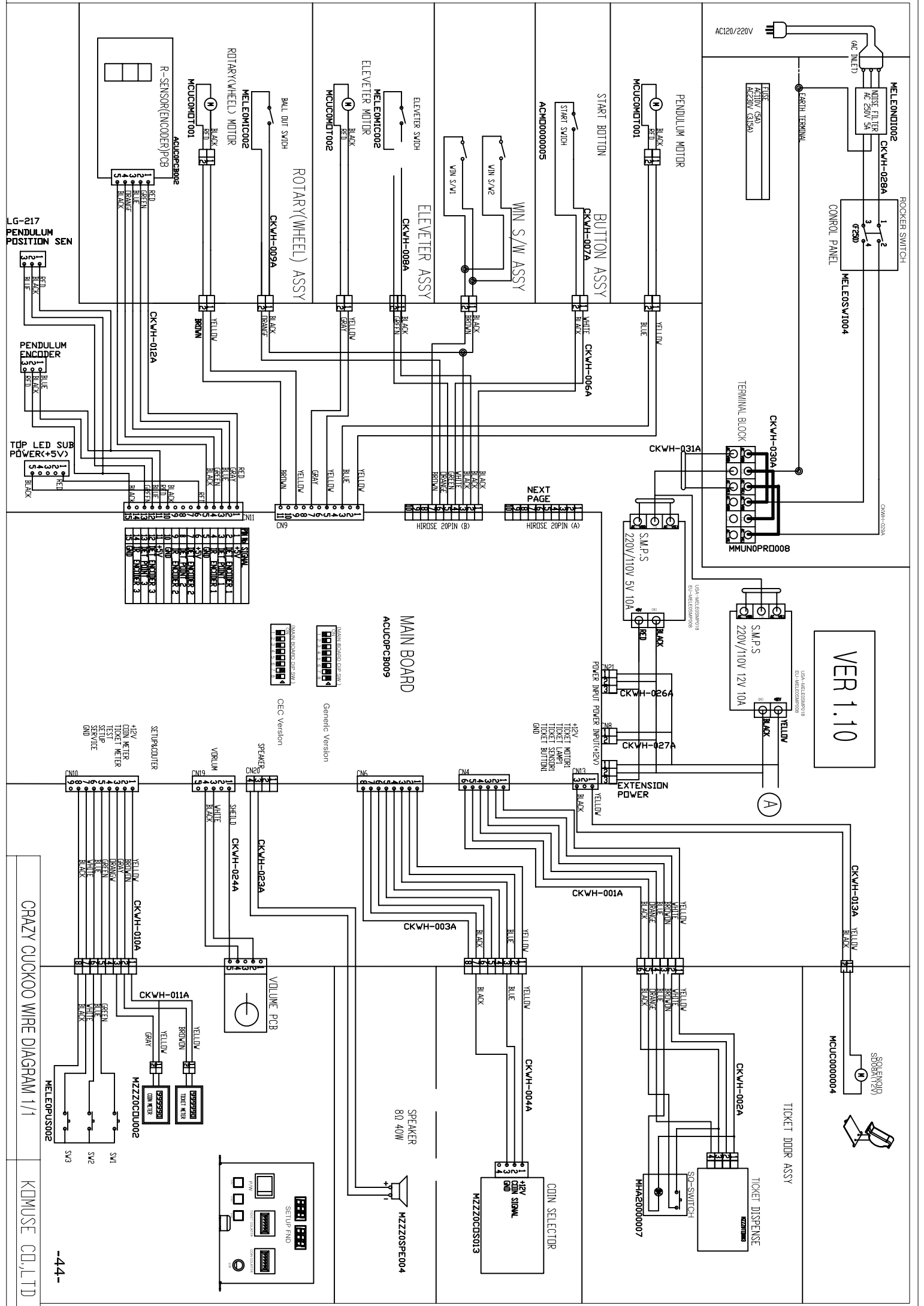

VER 1.10

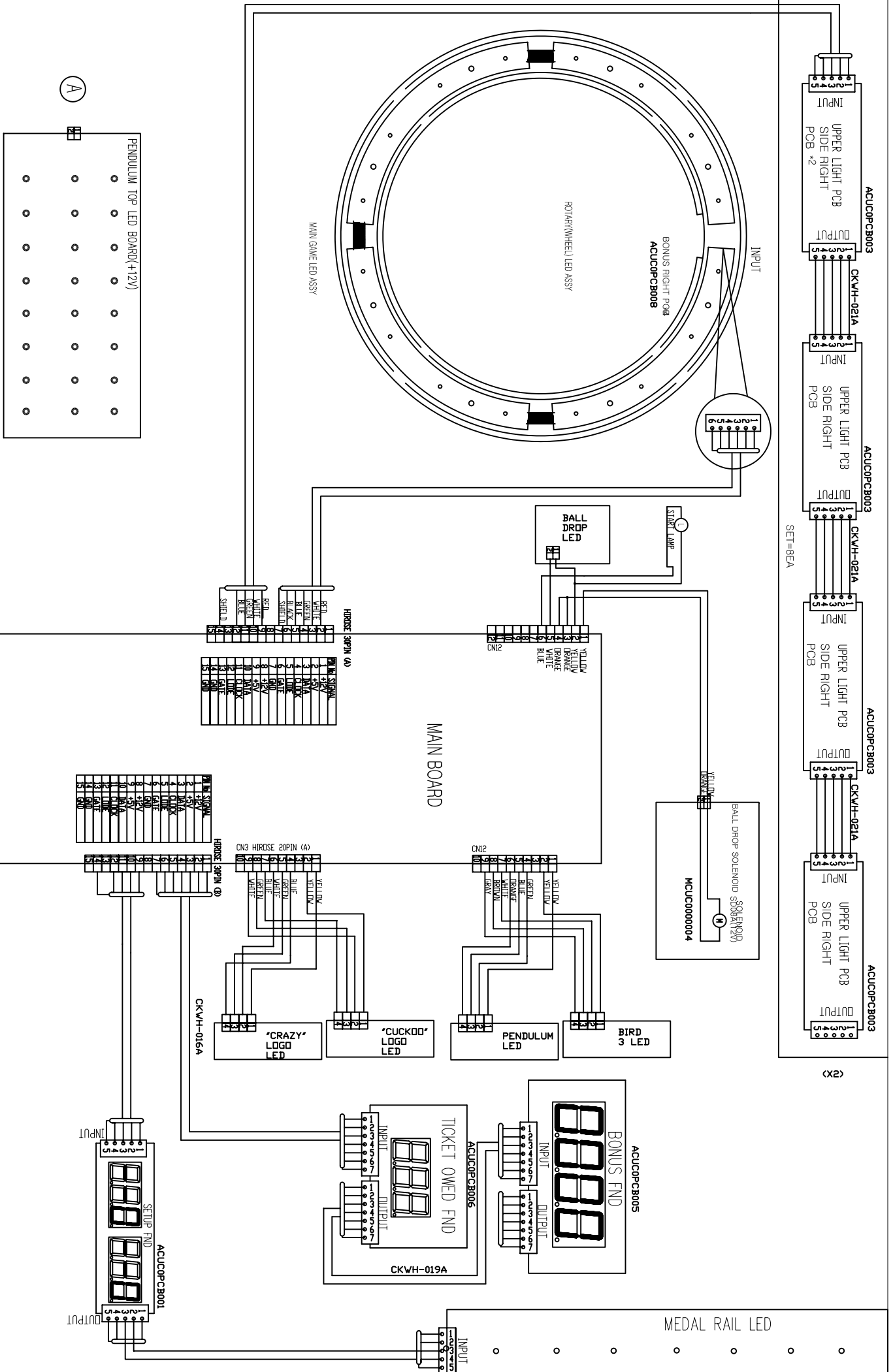



Sega Amusements U.S.A., Inc.

800 Arthur Avenue, Elk Grove Village, IL 60007-5215 U.S.A

Telephone: +1-847-364-9787

Toll free: +1-888-877-2669

Facsimile: +1-847-427-1065

<http://www.segaarcade.com>

Sega Amusements Europe Ltd.

42 Barwell Business Park, Leatherhead Road, Chessington, Surrey. KT9 2NY UNITED KINGDOM

Telephone: +44 (0) 208-391-8081

Facsimile: +44 (0) 208-391-8099

©SEGA

All manufacturers, cars, name, brands and associated imagery featured in this game are trademarks and/or copyrighted materials of their respective owners. All rights reserved.