



CONTENTS

Section		Page
1	Machine Description	4
2	Specification	6
3	Installation	7
4	Setup and Preparation	8
5	Loading Supplies	9
6	Cleaning	10
7	Preventative Maintenance	11
8	Test Procedures	12
9	System Book Keeping	14
10	Vend Price Adjustment	15
11	Troubleshooting	16
12	Mechanical Adjustments	35
13	Fig 1 – 19	38
14	Transistor Driver Identification	59
15	Wiring Diagrams.	60

1(a)

MACHINE DESCRIPTION

Cotton Candy is made by melting sugar using an electrically heated element which is rotating at high speed. The melted sugar is forced through a floss ring by centrifugal force forming very fine strands of sugar floss (also known as Cotton Candy). The floss is then collected on a stick rotating in the floss stream.

The entire mechanics are contained within a steel cabinet mounted on lockable wheels. The front door is hinged on the right-hand side to allow the operator to clean and re-stock the paper sticks while being secured with three individual locks on the left-hand side. The rear door also opens to allow access to the back portion of the machine where the sugar hopper, control P.C.B. volume control and spin speed control are located.

The customer will insert money into a MEI 2700 bill acceptor using \$1 OR \$5. There is also the option of the MEI 2700 with a built in recycler which has the facility of accepting \$1, \$5, \$10 and \$20 and giving change to the customer in \$1 bills. Coins may also be inserted using a coin mechanism located below the bill acceptor. When the proper amount of money equals vending price, the start button will commence flashing and indicate the machine is ready to operate. Meanwhile, the display mounted on the outside will indicate the status of the machine and instructions for its use.

When the start button is pressed, the following activities will begin...

- A) The floss spin head starts to rotate, eventually building up to between 5000 - 6000 RPM.
- B) The collection bowl (see fig 2 item 7) rotates counter clockwise in a circular motion. The heater element is turned on.
- C) The gripper head is rotated into a horizontal position allowing a stick to slide into it from the hopper. See Fig 7. This stick is moistened along its length by approximately two drops of water dripping from a nozzle located directly above the stick while being fed into the gripper head.

The stick rotates into a vertical position, secured by a small electrically operated D.C. solenoid (fig 7 item 1) mounted on the gripper head. The flap doors (fig 6) first open upwards and the stick is then lowered into the bowl. As it descends, the gripper mechanism is activated and holds the stick firmly, the DC solenoid is deactivated and the gripper head begins to slowly rotate.

At this time, a precisely-measured amount of sugar (approx 25 grams), sufficient to make an individual serving of Cotton Candy, is fed to the spinning floss head which is now pre-heated.

Cotton Candy (in the form of Floss) begins forming in the food grade plastic collection bowl (fig 2 item 7).

The moistened stick rotates, allowing a stream of hot Cotton Candy to attach to it. The cotton candy is then wound around the stick forming a cone or cylinder of floss.

After approx. 60 seconds of operation, the motors and heating elements are shut down and the stick now containing the Cotton Candy is raised up from the bowl into the vend chamber (fig 2 item 5). When raised to a sufficient height, the flaps close downward and form a flat serving surface in the vend chamber which now covers the bowl from view. At this time, the gripper head opens and the Cotton Candy is released into the vend chamber for collection by the customer.

1(b)

The customer is now able to open the Vend Door as the interlock solenoid (fig 4 item 3) is now de-activated. The customer slides the vend door upwards and reaches into the vend chamber to get their Cotton Candy. When the door is released, it again closes into a locked position after 3 seconds.

Information regarding number of credits, price per vend, etc is shown on the front door display when the machine has completed one cycle.

All the power devices operate on 120 AC Voltage, which is enabled via a heavy duty relay only after the start button is activated and is disabled when either front or rear door is open.

The system is controlled and sequenced by a custom micro processor unit (fig 14 item6) and housed in a ventilated compartment.

In the event that the machine fails to complete a task, it will “Time Out” and the complete system will shut down. It can only be restarted by a system reset. A diagnosis of the problem will be shown on the front door display.

NO attempt should be made to restart the machine until the cause has been investigated and corrected by an Authorized Service Technician.

NOTE:

To protect the vend door solenoid coil, the vend door “Times Out” after 25 seconds if it has not been opened and closed during this time. The door cannot be opened by hand. The locking bolt may be opened manually by inserting a paperclip or pin into a small hole (approx 1.5mm) to be found on the front door. See photo below.



Insert pin or paper clip to depress solenoid plunger. Lift vend door while simultaneously withdrawing the pin.

2

SPECIFICATION

DIMENSIONS

Shipping

HEIGHT 79 inches
WIDTH 39 inches
DEPTH 30 inches

WEIGHT 540 lbs.

Installed

HEIGHT 72 inches
WIDTH 34 inches
DEPTH 26 inches

WEIGHT 463 lbs.

POWER SUPPLY 110-120 V AC 1200 V.A

MICRO PROCESSOR ATMEGA 128

COIN MECHANISM HI-06 COMPARATOR or MONEY
CONTROLS SR3

BILL VALIDATOR MEI 2700 WITH OPTIONAL BILL
RECYCLER.

FLASH MEMORY 64MB FLASH CARD (FOR MUSIC)

SOUND MP3 SYSTEM
AMPLIFIER STEREO
15 WATT PEAK POWER

3

INSTALLATION PROCEDURE

WARNING

Access to the electrical and internal components as described in this manual should only be undertaken by a qualified service technician with proper training.

PLACING ON LOCATION

- 3.1 Make certain all parts and connections are secure.
- 3.2 Machine must be located on a level and stable flooring. Avoid locations with extreme dust.
- 3.3 This machine is designed for indoor use. If used outdoors it should be fitted with a customized canopy and power supplied via a protected electrical outlet. The machine should be taken indoors or covered with an insulated wrap at night to prevent condensation on internal metal surfaces.
- 3.4 The machine may be secured in place by locking the brakes on the rear wheels and/or by using a chain attached to a permanent structure.

ELECTRICAL SUPPLY

THIS MACHINE MUST BE GROUNDED

If used outdoors, the electrical supply MUST come from a GFI PROTECTION OUTLET.

This machine must be connected to the outlet using an approved plug protected by a fuse not exceeding 13 amps.

Ensure that the cord does not exceed 10 feet.

If this machine does not have a suitable plug for your outlet, the plug should be removed and replaced with an appropriate one.

VERY IMPORTANT INFORMATION!!!

<p>GREEN AND YELLOW = EARTH/GROUND WHITE = NEUTRAL BLACK = LIVE/HOT</p>

4 SET UP & PREPARATION

DO NOT PLUG THE MACHINE UNTIL ALL STEPS COMPLETED

- 4.1 Unlock and open the front door.
- 4.2 Cut and remove cable ties securing the vend arm. Remove the spin head shipping bolts using the 6mm allen wrench supplied (see photo below) and retain for future reuse in transporting unit. Remove the tape securing the stick and sugar hopper lids.

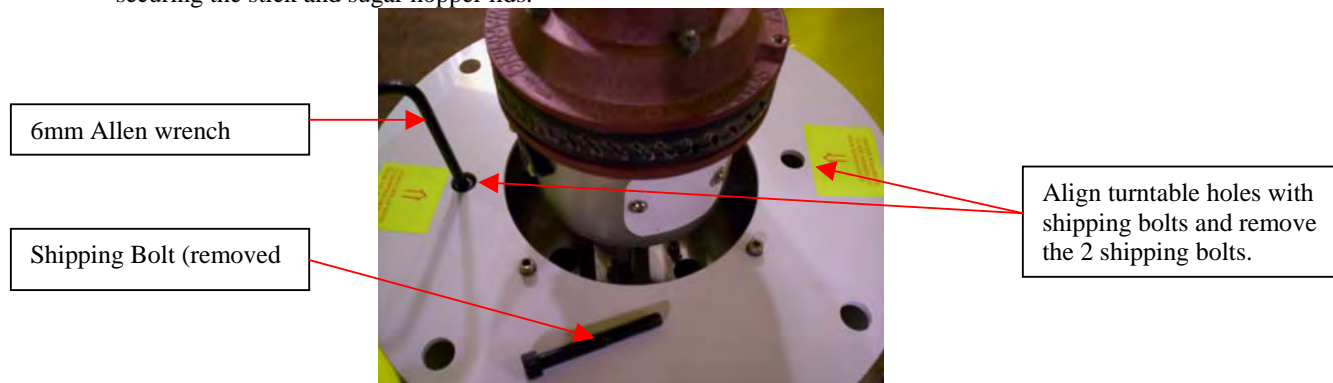

- 4.3 Ensure there is no debris or foreign object inside the cabinet, especially near the spin head. It is recommended that you vacuum the inside of the spin head and the cabinet to be certain.
- 4.4 Remove the bowl cover and the bowl, wash both with hot water. Dry thoroughly before replacing.
- 4.5 The stainless steel surfaces should also be cleaned using hot water and dried thoroughly.
- 4.6 Re-assemble the bowl, ensuring both pegs under bowl base fit securely into slots in the turntable.
- 4.7 Refit bowl cover and tighten all 3 thumb screws.
- 4.8 Open the electronics compartment; ensure the logic P.C.B. is pushed securely into the edge connector. Locate volume output level of the sound amplifier at rear area of electronics compartment and adjust to required volume (see section 8.12 on the sound test) and close the compartment cover.
- 4.9 Ensure that there is no restriction or obstructions to the free movement of the robotic arms, both horizontal and vertical.
- 4.10 Attach the machine connector to the power source and switch on, while standing back from unit.
- 4.11 The machine will initialize and return all actuators to their normal start position; the front door display reads "FRONT DOOR OPEN".

HINT -To enable motors which are not "at-home position". To reset, turn on service key switch (Fig 1 item 2) with door open. (Please note this will activate the electrical circuits within the machine and caution will have to be observed as components may begin to move and can cause injury).

- Should more than one actuator be off the home position, it may be necessary to reset manually by raising the vend arm manually using the motor shaft (Fig 12 item 10). For example, if the flap doors are open.

- The vend door solenoid "times out" if a finished product is not removed from the vend chamber in 25 seconds. To open the vending door and temporarily release the solenoid, insert a paperclip or a pin in the small hole located on the front door decal. See photo on page 5.

5

LOADING SUPPLIES

This machine requires a supply of: - **PAPER STICKS 5mm x 300mm**

**VERY IMPORTANT INFORMATION!!!
THIS STICK SIZE IS CRITICAL FOR CORRECT OPERATION WITH THIS
MACHINE. FAILURE TO USE THESE STICKS SUPPLIED BY AND PURCHASED
THROUGH COTTONCANDYVENDING.COM WILL VOID FACTORY WARRANTY!**

- **GRANULATED SUGAR**

- **CLEAN WATER**

Please familiarize yourself with the location of the relevant containers by referring to FIG. 1 & 2

- 5.1 Locate and fill the water container with clean water by unscrewing top. Reattach by depressing the metal catch on the pipe fitting and pushing the container until it latches into place.
- 5.2 Push and hold the pump priming switch (Fig 12 item7) until water starts dripping, and then count 50 drips it should drip at a rate of 1 drip per second. During operation, an average of 2 drops will wet the stick.
- 5.3 Add a supply of paper sticks to the stick hopper, stacking horizontally and ensuring all are lying flat and straight. Maximum capacity of hopper is 1,200 sticks. (Use disposable gloves when handling the sticks).
- 5.4 Fill the sugar hopper with approx. 22 lbs. of sugar (enough for 400 vends). Make certain that the sugar remains completely dry and free from lumps. Sugar will dispense more evenly when the hopper level is maintained at a proper level and quality. Do not transport the machine with sugar in the hopper.
- 5.5 Fit covers on both stick and sugar hoppers.
- 5.6 Close and lock front and rear doors. The machine is now ready for use. A moving "ATTRACT MODE" will now appear on the front door display.
- 5.7 Set vend price - see section 10.
- 5.8 A number of flavors and colors may be added to the sugar before loading the hopper. It is recommended to mix any additives thoroughly with the sugar in a separate container prior to filling the hopper and not exceed the recommended quantity or proportions.

Regular granular sugar purchased from supermarkets can be used in the operation of this machine.

Powdered or caster sugar should not be used in this machine.

6.1

CLEANING **Cleaning the Cotton Candy Bowl** **Weekly**

- **Before any cleaning is carried out insure the machine is switched off at the mains.**
Unlock the front door, Undo the 3 black thumb screws that hold the bowl lid in place, lift the central sugar feed tube and remove the bowl lid.
- With the central sugar feed tube still held up remove the white plastic cotton candy bowl.
- The cover plate and bowl need to be washed using hot water, rinsed, sanitized, and completely dried using paper towel to remove any excess water.
- Replace the bowl first by lifting the central sugar feed tube and ensuring that the 2 lugs on the bottom of the bowl are fitting into the relevant holes on the plate which the bowl sits.
- With the central sugar feed tube still lifted now replace the cover tray on top of the bowl and replace the 3 black thumb screws, ensuring the sugar tube is lowered so it sits just inside the main spin head.
- Fill the sugar container as required using sugar from the stock supplied and replace lid.
- Use only hot water to wash the shelf to remove the build up of sugar, then wipe dry with paper towel to bring back the shine.
- Wash and polish the glass panels inside and out on the front door, again drying using paper towel.

6.2

Cleaning the Vend Chamber **Daily**

- **Before any cleaning is carried out insure the machine is switched off at the mains.**
- Using a small pin or paper clip, insert into the small hole located in the on the front door decal. See page 5. Locate this hole by looking at the outside of the door opposite the vend door solenoid, (Fig 4 item 3) inside front door, then slide the clear vend chamber door up.
- Using hot water wash the chamber and stainless steel vend doors; ensure they are completely dried with paper towel.
- Open the main door and wipe clean the inside of the vend chamber plastic door, again drying with paper towel.

Close the door and re lock. Inspect the external casing of the machine and wipe clean as necessary.

- 6.3 It is also very important to clean the extraction fan in the rear door. Open the back door and brush off any surplus sugar with a stiff brush, then wipe with a slightly damp cloth (not dripping wet).
- 6.4 Cleaning the gripper head is essential to ensure sticks are gripped tightly when making cotton candy and released properly when finished. Use a dry bottle brush only (NOT WET CLOTH) to clean the gripper head periodically. Examine the gripper head and the pusher thoroughly for any deposits of sugar and remove by brushing. It is important that moisture be kept away from these moving parts or syrup could form and impair operation. Dry off thoroughly with cloth when clean.
- 6.5 Need for cleaning is dependent on the level of use. The quality of the product is reduced if there is a buildup of deposits on the bowl and crystallization has occurred.

7.0 Preventative Maintenance.

In addition to cleaning, the following steps should be carried out and corrective action taken where necessary.

Weekly

- Carry out all test functions from 0 through to E detailed in section 8. If any function is not operating or out of adjustment report the problem immediately to a qualified service technician.
- Empty the water container and refill with fresh water.
- Operate the water pump prime switch to bleed the system and check the operation of the pump.
- Ensure that the paper sticks in the stick hopper are loaded correctly, and remove any bent sticks to reduce the possibility of stick feed problems.
- Press the service button, close the front door and make a cotton candy.

Quarterly

- Remove bowl and visually inspect for cracks. Replace if required.
- Remove the carbon brushes (fig 18a item 4) and check for wear. Replace if required.
- Remove the inspection cover (Fig 17a item 3) and clean the brass rings with fine abrasive paper (typically 800 grade) and clean with a solvent.
- Perform a spin head clean to remove any build up of sugar in the spin head. Visually inspect the floss band (Fig 17a item 2) for damage or wear.
- Remove the sugar hopper and empty the contents into a clean container. Rotate the sugar coupling by hand (counter clockwise) and check that the mechanism rotates freely. Refill with sugar and refit.
- Wash out water container. Refill and prime water system.
- Brush clean the top and bottom air vents on the rear door.
- Check the stick holding tension (Section 12) and adjust if required. Also check that the stick drops under its own weight when released.
- Check power cord for damage. Avoid using long extension cords.
- Check the exterior of the machine cosmetically. Replace damaged graphics, labels, or windows.
- Check all door locks and tighten retaining nuts if required.

• **8(a)** **TEST PROCEDURES**

8.0 ONLY authorized, qualified and properly trained personnel should carry out these test procedures. These have been designed to check adjustments as well as individual machine functions, then properly correct as needed.

THE FOLLOWING TEST PROCEDURES CAN ONLY BE PERFORMED WITH THE FRONT DOOR UNLOCKED & OPEN AND THE SERVICE KEY INSERTED INTO THE KEY SWITCH LOCATED ON THE FRONT EDGE OF THE EQUIPMENT SHELF AND THE KEY TURNED IN THE “ON” POSITION (TURNED TO THE RIGHT)

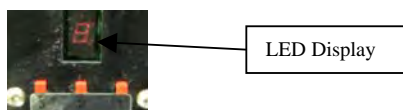

Three push buttons are used in tests, located on front panel inside machine and designated 1, 2 & 3 from right to left. The action corresponding to each test is displayed on the “Front Door Display” while the LED display on the control panel indicates the “Test Number”.

A reminder label of the test numbers and their description can be found inside the front door.

8.1 **PUSH BUTTON 1** - Display reads **0**, **PUSH BUTTON 2** to enter test

TEST - “VEND ARM TO LOAD” POSITION

This test checks the “gripper head” is in the correct position, to receive the stick, i.e. it should be horizontal. An emerging stick should be centered in the gripper head. Its alignment may be checked by pushing a stick through the head from the left hand side and ensuring it lines up with stick emerging from the “stick hopper”. Adjustment should be made using the stop adjustment nuts on the actuating lever. If this doesn't give the required adjustment, adjustment of proximity detector A (Fig 5) or the top mechanical stop may be necessary. (See section 12)

8.2 **PUSH BUTTON 1** - Display reads **1**, **PUSH BUTTON 2** to enter test.

TEST - “LOAD STICK”

A stick is pushed from the hopper into the gripper head. The stick should be centered in the gripper head entry funnel opening.

8.3 **PUSH BUTTON 1** - Display reads **2**, **PUSH BUTTON 2** to enter test.

TEST - “OPERATES AND RELEASES GRIPPER SOLENOID

8.4 **PUSH BUTTON 1** - Display reads **3**, **PUSH BUTTON 2** to enter test.

TEST - “VEND ARM LOWERS INTO BOWL AND STOPS”

The gripper head is mechanically activated at the bottom of the stroke by a SWINGING DETENT ARM and the stick will be held firmly. Listen for the detent arm clicking positively into place otherwise the stick will drop when the vend arm commences to rise in test 4. The solenoid now releases and the stick commences to rotate about its axis. Check grip by holding the stick during rotation between finger and thumb.

8.5 **PUSH BUTTON 1** - Display reads **4**, **PUSH BUTTON 2** to enter test.

TEST - “VEND ARM RAISES AND STOPS AT HOME POSITION

After pausing momentarily to permit the flaps to close

The stick should release under its own weight, indicating friction free operation of the collet in the vertical position.

8.6 **PUSH BUTTON 1** - Display reads **5, PUSH BUTTON 2** to enter test.

TEST - “FLAPS ON BOTTOM OF THE VEND CHAMBER OPEN AND CLOSE ALTERNATLY ON EACH PUSH OF BUTTON 2”

8.7 **PUSH BUTTON 1** - Display reads **6, PUSH BUTTON 2** to enter test.

TEST - “ROTATE DRUM”, DRUM (BOWL) ROTATES

8.8 **PUSH BUTTON 1** - Display reads **7, PUSH BUTTON 2** to enter test.

TEST - “OPERATE SUGAR FEED MOTOR”

This feeds sugar into the spin head via the sugar feed tube. The sugar should be collected by placing a container under the end of the tube. Check sugar for quantity which should be 25 grams.

8.9 **PUSH BUTTON 1** - Display reads **8, PUSH BUTTON 2** to enter test.

TEST - “STICK AGITATOR SOLENOID ACTIVATED”

This is called up in operation each time a cotton candy is made and when **LOW STICK LEVEL** sensor is active

8.10 **PUSH BUTTON 1** - Display reads **9, PUSH BUTTON 2** to enter test.

TEST - “SPIN MOTOR ROTATES”

The spin motor rotates in an anti clockwise direction picking up speed over 15-20 seconds until it stabilizes. A normal reading on the door display would be 5500 (\pm 300) RPM. The speed control adjuster is located on the rear of the spin motor housing (fig 3a item 4). To increase the speed turn the adjuster counter clockwise (CCW). The spin motor will “time out” after 30 seconds. To restart the test, press button 2.

8.11 **PUSH BUTTON 1** - Display reads **A, PUSH BUTTON 2** to enter test.

TEST - “NOTE VALIDATOR TEST”

Insert \$1 or \$5 the front door display gives the value of the first note accepted.

8.12 **PUSH BUTTON 1** - Display reads **B, PUSH BUTTON 2** to enter test.

TEST - “SOUND TEST”

Continue to push 2 to select different tracks from the library including speech. Set the volume level if necessary using the volume control on the main PCB.

8.13 **PUSH BUTTON 1** - Display reads **C, PUSH BUTTON 2** to **CLEAR STORED FAULTS and REPORT “FAULT CLEARED & MACHINE SATISFACTORY “ to the Telemetry System**

8.14 **PUSH BUTTON 1** - Display reads **D, PUSH BUTTON 2** to read the number of vends remaining until stick re-order.

8.15 **PUSH BUTTON 1** - Display reads **E, PUSH BUTTON 2** to exit test mode.

REMOVE KEY SWITCH BEFORE CLOSING FRONT DOOR.

9 BOOKKEEPING FEATURES

WITH FRONT DOOR OPEN

PUSH BUTTON 3 - TO ENTER BOOKKEEPING FUNCTIONS

PUSH 2 TO SCROLL THROUGH EACH OF THESE STEPS WHICH ARE NOW DISPLAYED ON FRONT DOOR DISPLAY

1. **ONS - NUMBER OF TIMES THE MACHINE HAS BEEN SWITCHED OFF AND ON.**
2. **ST VENDS – NUMBER OF COTTON CANDY MADE SINCE LAST RESET.**
3. **LT VENDS - TOTAL AMOUNT OF COTTON CANDY MADE**
4. **SERVICE - NUMBER OF SERVICE (FREE) VENDS**
5. **ST COIN – VALUE OF COINS ACCEPTED SINCE LAST RESET**
6. **ST NOTE - VALUE OF BILLS ACCEPTED SINCE LAST RESET**
7. **LT NOTE- TOTAL VALUE OF COINS ACCEPTED**
8. **LT NOTE TOTAL VALUE OF BILLS ACCEPTED**
9. **COUPON – NUMBER OF COUPONS ACCEPTED**
10. **CASHBACK – VALUE OF NOTES GIVEN IN CHANGE SINCE LAST RESET**
11. **RESET METER READINGS (push button 3 to reset readings) THIS RESETS O.N.S AND ST READINGS**
12. **EXIT METER READINGS**

If the machine is fitted with a recycler the value of bills in the stacker will equal the ST NOTE reading minus the CASHBACK reading provided that the recycler is full of change at the start and end of the day. The recycler holds a maximum of \$30 in \$1 bills. Any \$1 bills inserted after the recycler is full will be diverted to the stacker.

IMPORTANT: ALL READINGS OR NUMBERS WILL BE ERASED IF THE BOARD IS REPROGRAMMED. IN NORMAL OPERATION, ONLY CURRENT READINGS ARE ZEROED.

The machine also has a “hard meter” which cannot be reset. This is visible through a slot in the bottom left of the electronic compartment cover. This will show the total number of vends completed by the machine during its lifetime.

10

VEND PRICE ADJUSTMENT

These are programmed in the software and are selected using the Dip switches. (Fig 12 item 4)

No change is given. The “start lamp” commences flashing when sufficient money is inserted each time.

0 - OFF

1 - ON

VEND PRICE	1	2	3	4	5	6	7	8
\$1	0	0	0	0	0	0	0	0
\$1.50	1	0	0	0	0	0	0	0
\$2	0	1	0	0	0	0	0	0
\$2.50	1	1	0	0	0	0	0	0
\$3	0	0	1	0	0	0	0	0
\$4	1	0	1	0	0	0	0	0
\$5	0	1	1	0	0	0	0	0
\$6	1	1	1	0	0	0	0	0
	0	0	0	0	I	0	0	0
FREE PLAY	0	0	0	1	0	0	0	0
ATTRACT MUSIC OFF	0	0	0	0	0	1	0	0
HIGH AMBIENT TEMPERATURE	0	0	0	0	0	0	1	0
TEXT LANGUAGE	0	0	0	0	0	0	0	1

*THIS SETTING CONTROLS A COOLING PROGRAM WHICH IS INSTALLED IN HIGH USAGE MACHINES WHERE TEMPERATURES CONSISTENTLY EXCEED 80F FOR LONG PERIODS OF TIME.

ONLY authorized, qualified and properly trained personnel should carry out ANY functions or change settings

11

TROUBLESHOOTING

Before carrying out the repair procedures listed below it is good practice to carry out a visual inspection of all the components. Then check the fuses located in the rear of the machine and the fuses located inside the PCB housing.

Listed are the fault codes that are displayed on the front panel if the machine faults. If an alternate language is selected using switch 8 the errors are given a number.

Fault Text	Flow Chart Number
Vend door open (error 3)	11a
Door cycle (error 4)	11b
Stick feed error (error 5)	11c
Vend top error (error 6)	11d
Vend home error (error 7)	11e
Vend lower error (error 8)	11f
Spin motor fault (error 9)	11g
Flap open error (error 10)	11h
Flap close error (error 11)	11i
I2c bus error (error 12)	11j

These are flow charts for issues that might be experienced

	Flow Chart Number
No power to the machine	11(k)
Small sized product	11(l)
Stick not picking up floss	11(m)
Floss forming around spin head	11(n)
Stick not feeding into gripper head	11(o)
Gripper head not returning to vertical position following stick feed	11(p)
Dropping sticks	11(q)
Burning smell or excessive smoke	11(r)

Checking proximity detectors

When there is no magnet near the end of the proximity detector there should be no continuity through the switch (no circuit).

When the magnet is approximately 5mm from the end of the proximity detector, it activates the contact inside the proximity detector and permits continuity through the detector. (Less than 1 ohm measured with an ohm meter).

11(a)

Vend door Open

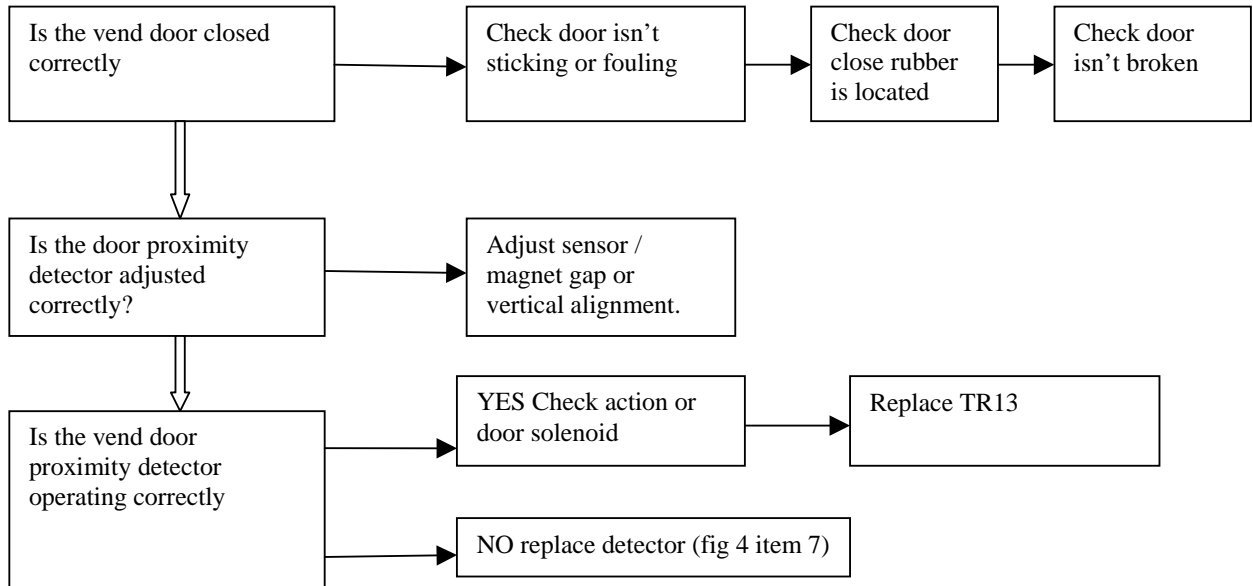

11(b)

Door cycle (Flap doors continually opening and closing)

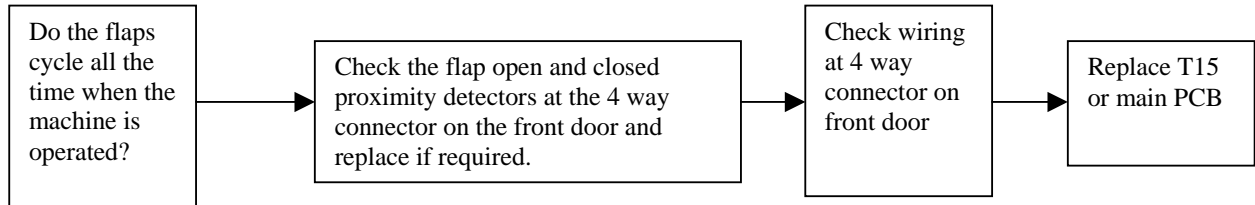

11(c)

Stick feed error

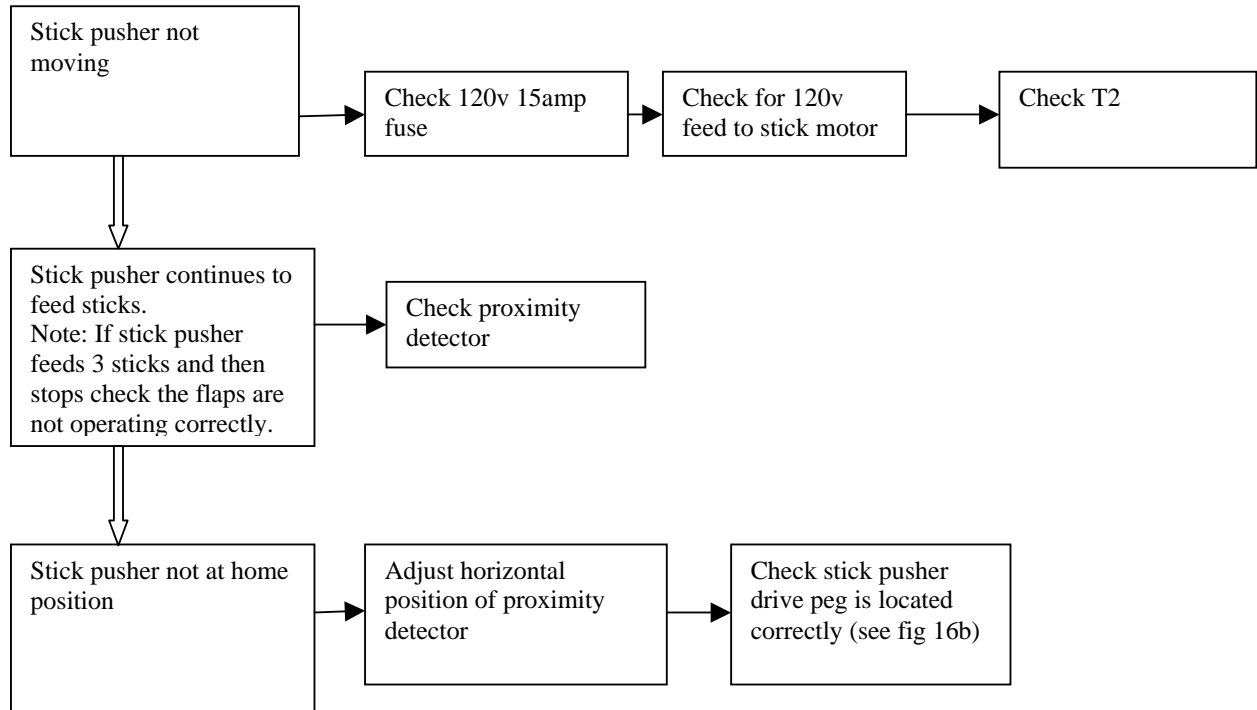

11(d)

Vend top error

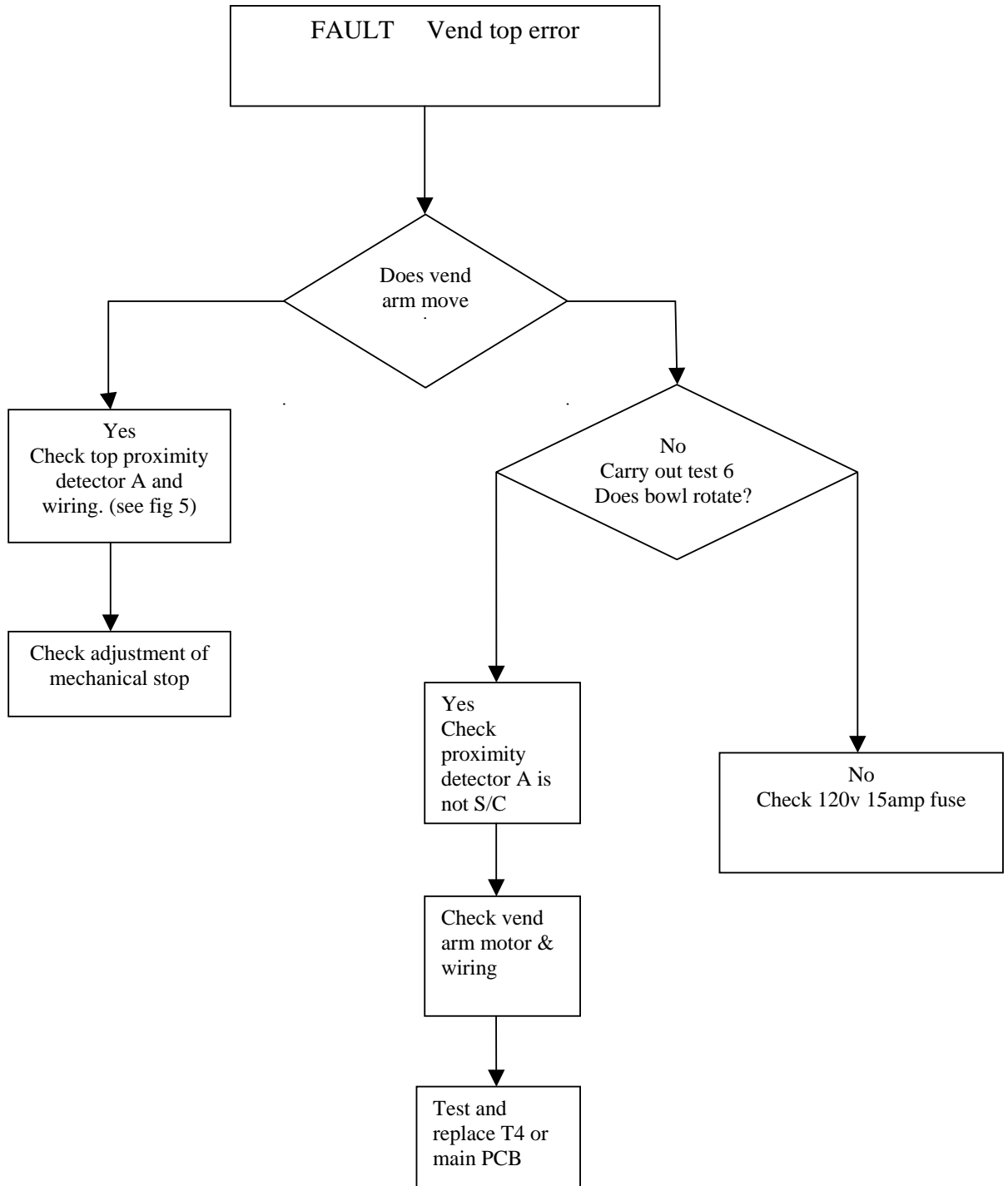

11(e)

Vend home error

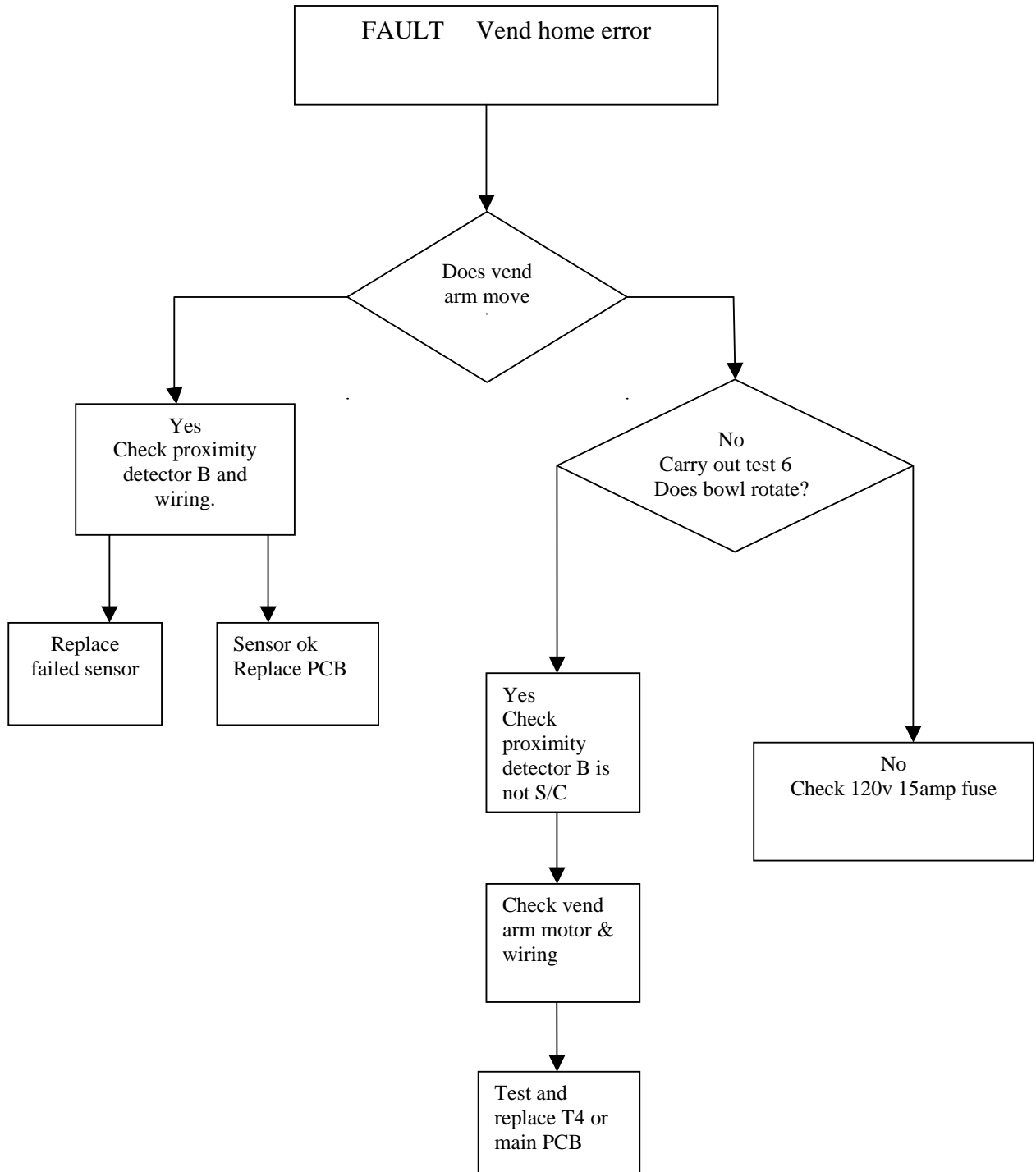

11(f)

Vend Lower Error

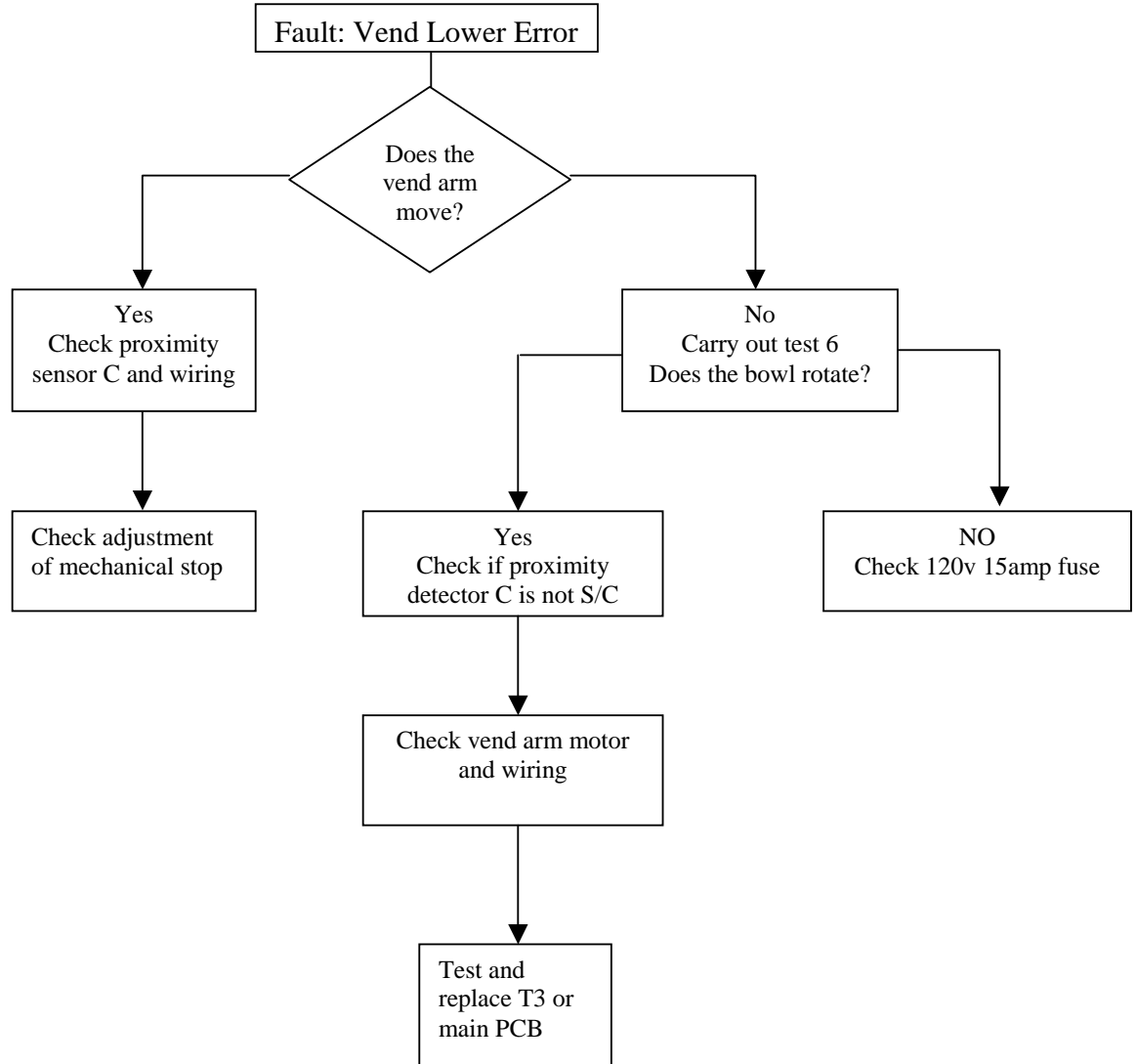

11(g)

SPIN MOTOR FAULT

If this fault occurs while making cotton candy first check that the front and rear doors are closed properly and the door strikers are properly aligned with the interlock switches. If the spin motor runs in test mode with the service key operated but not with the doors closed check the electrical interlock switches.

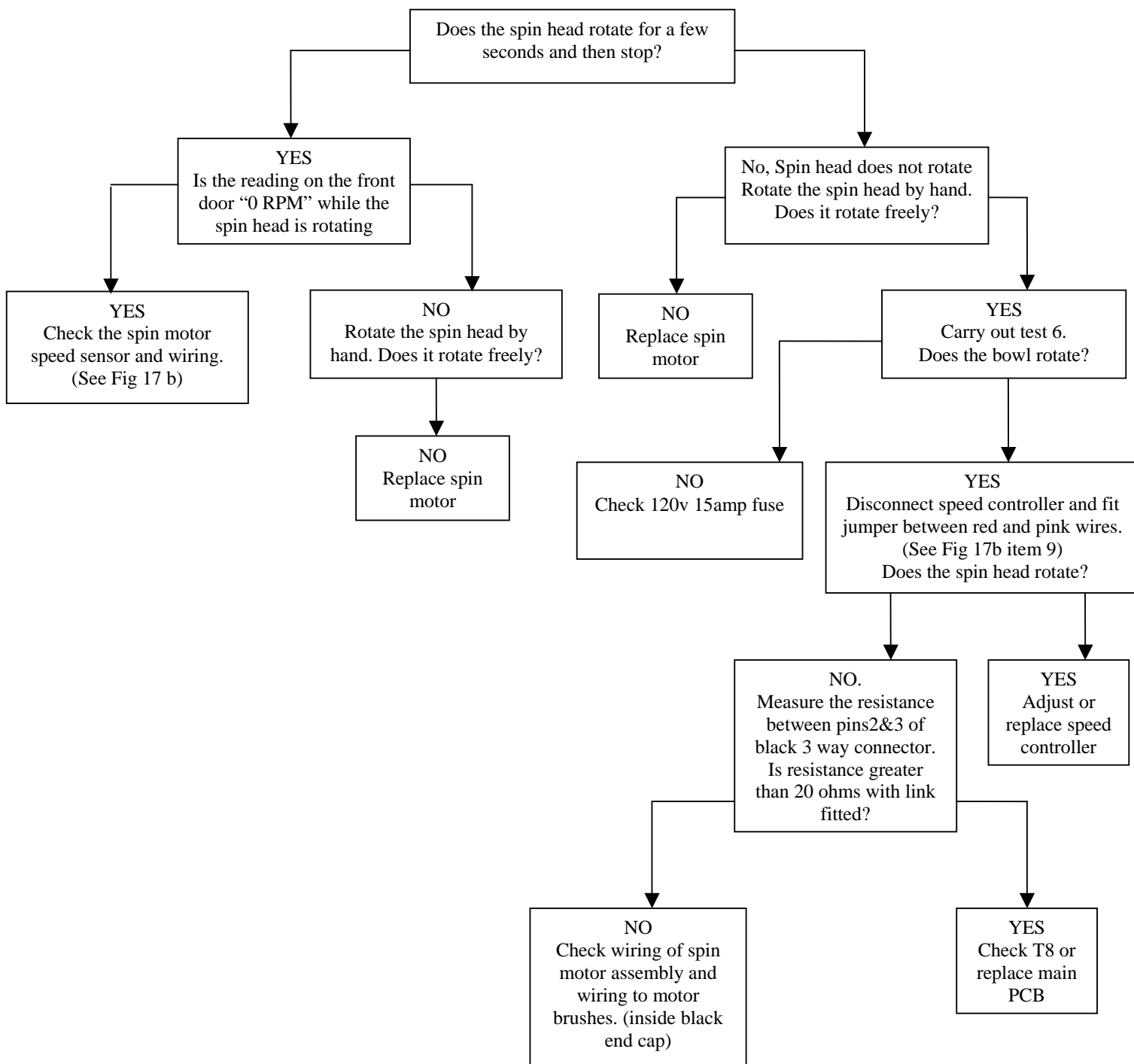

11(h)

Flap open error

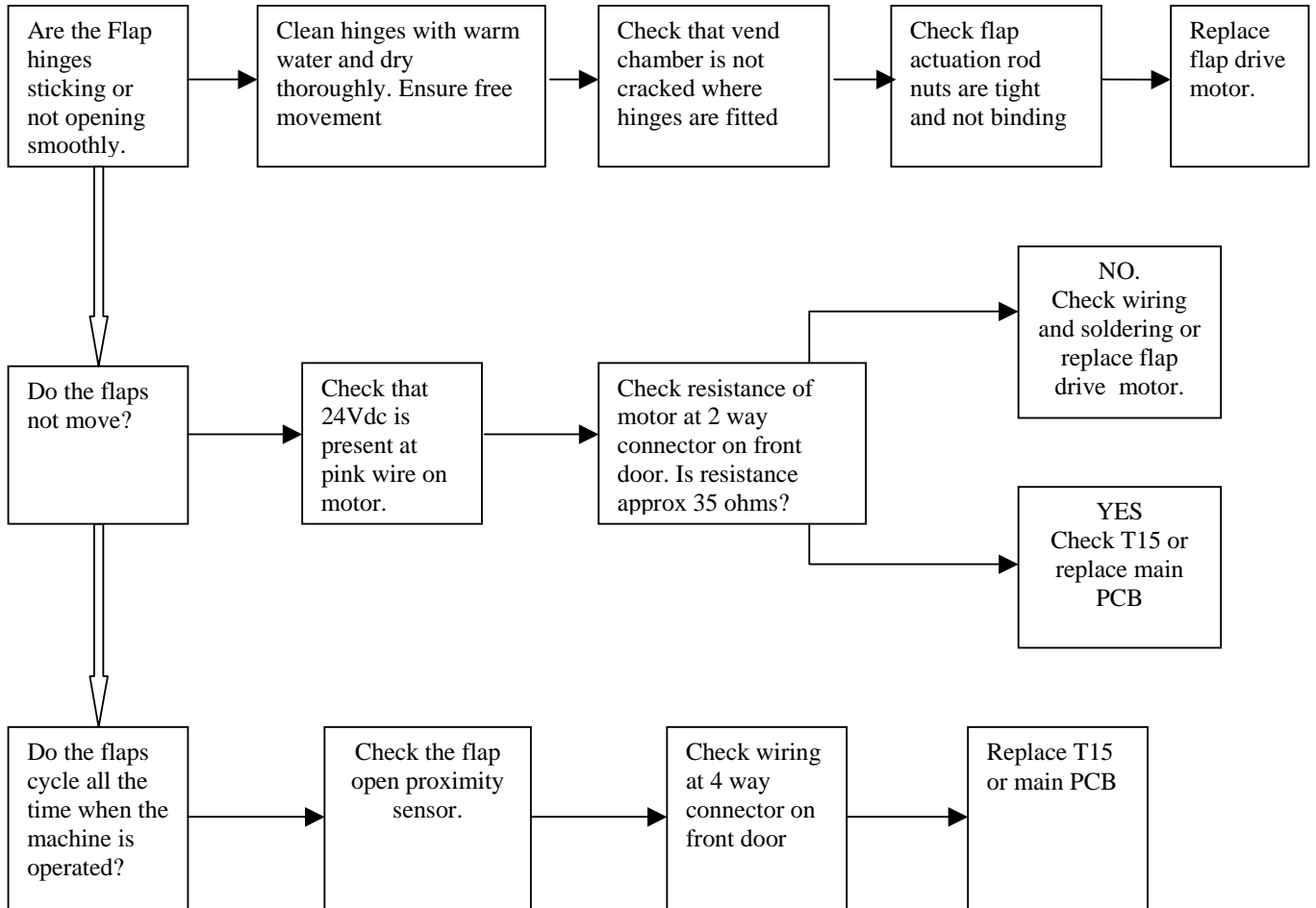

11(i)
Flap close error

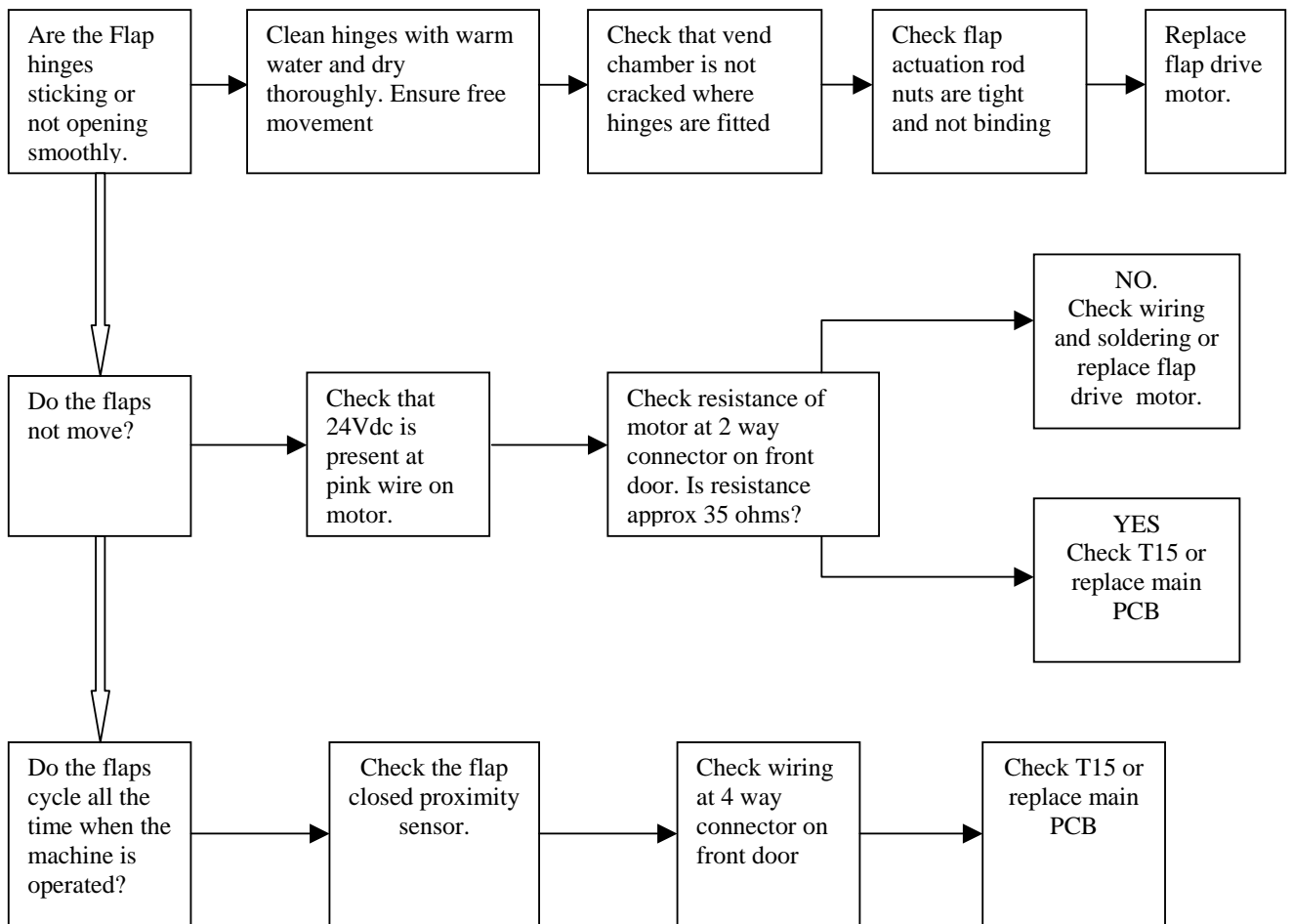

11(j)

I2c Bus error

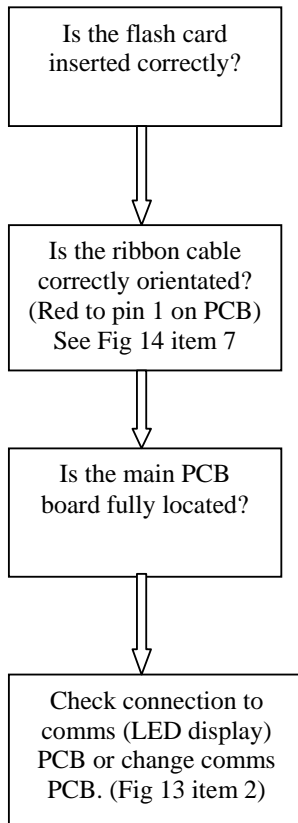

11 (k)

NO POWER TO THE MACHINE

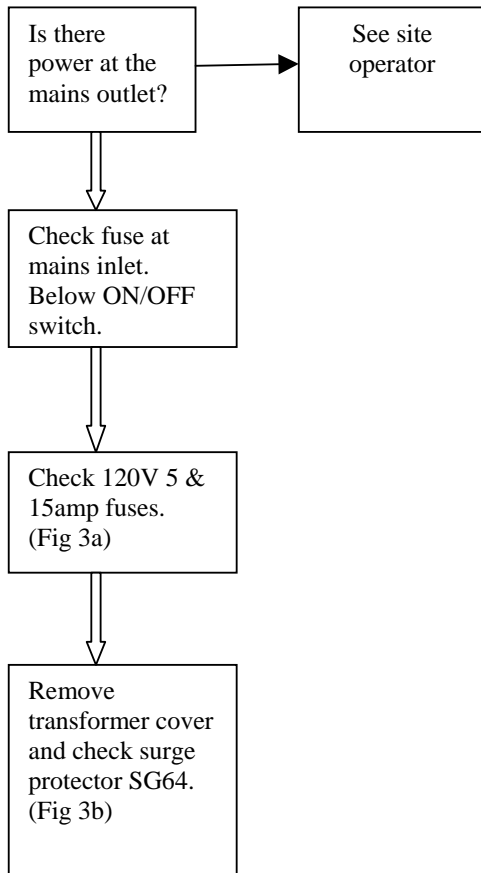

11(I)
Small Product

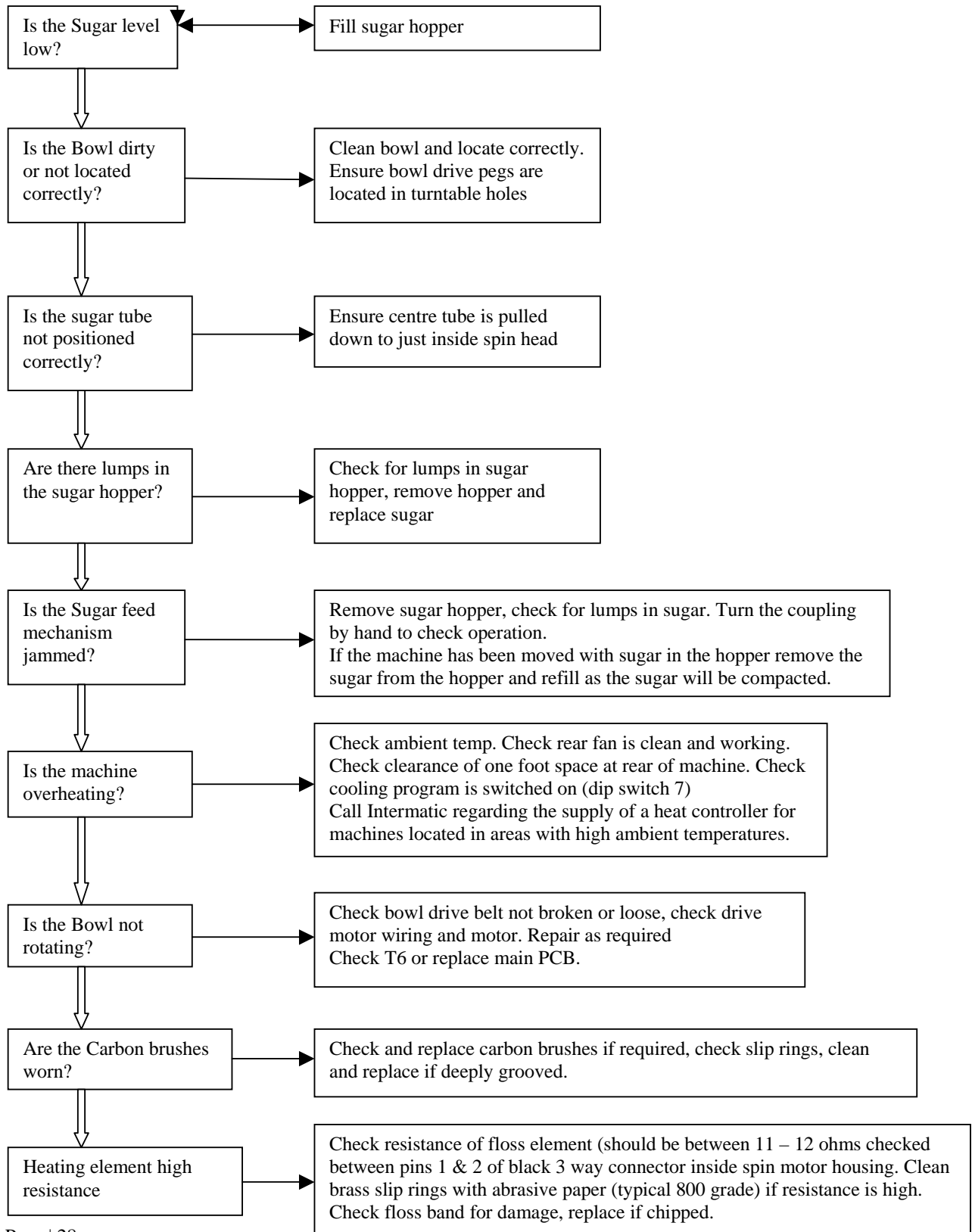

11 (m)

Stick Not Picking up Floss

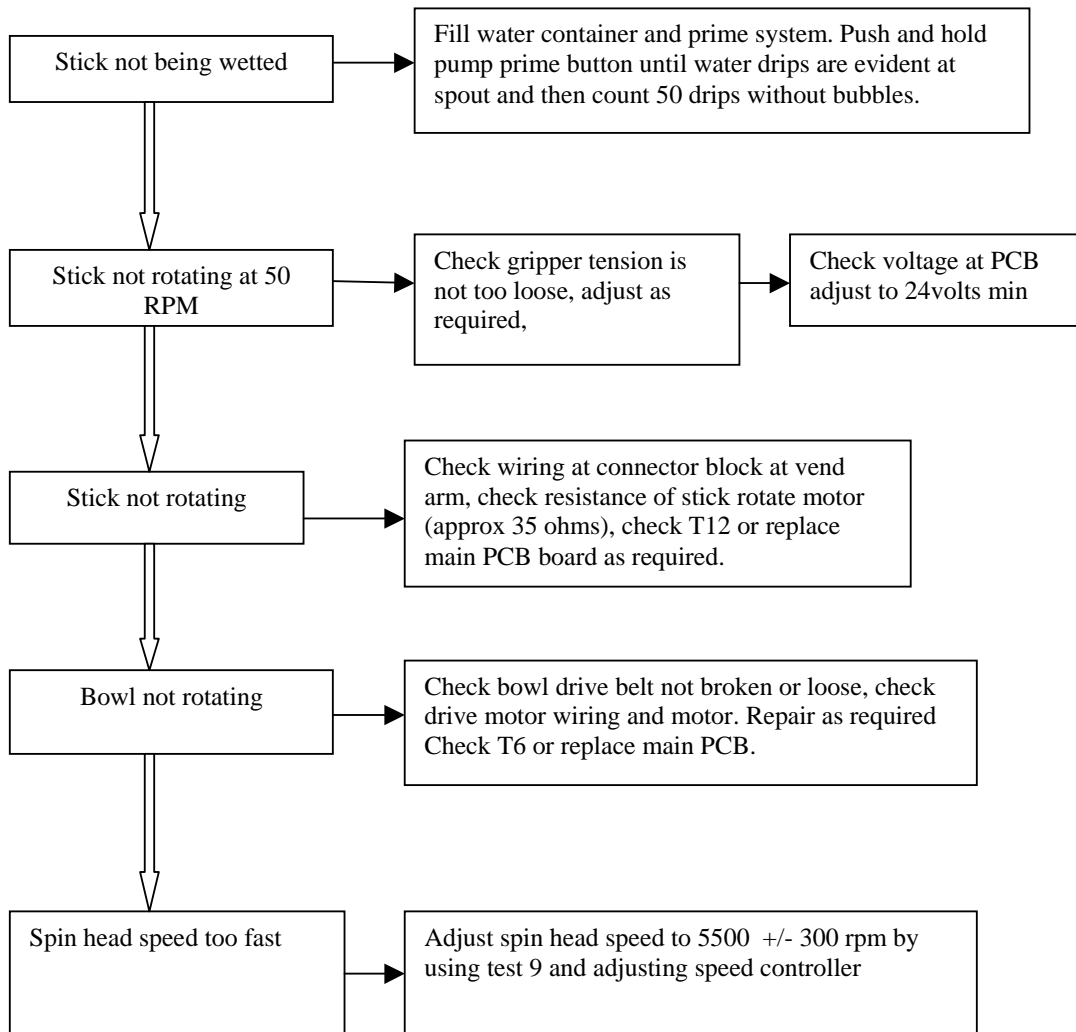

11 (n)

Floss Forming Around Spin Head

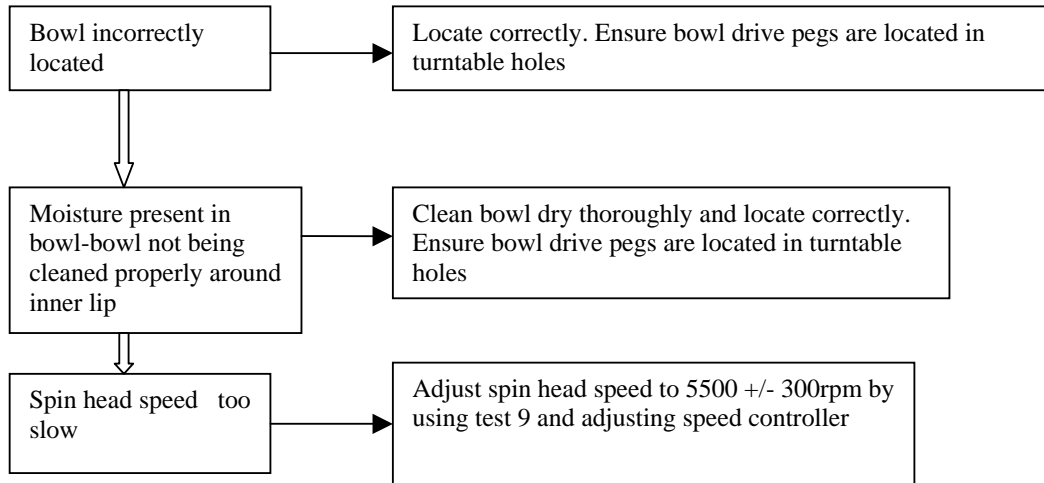

11 (o)

Stick Not Feeding into Gripper Head

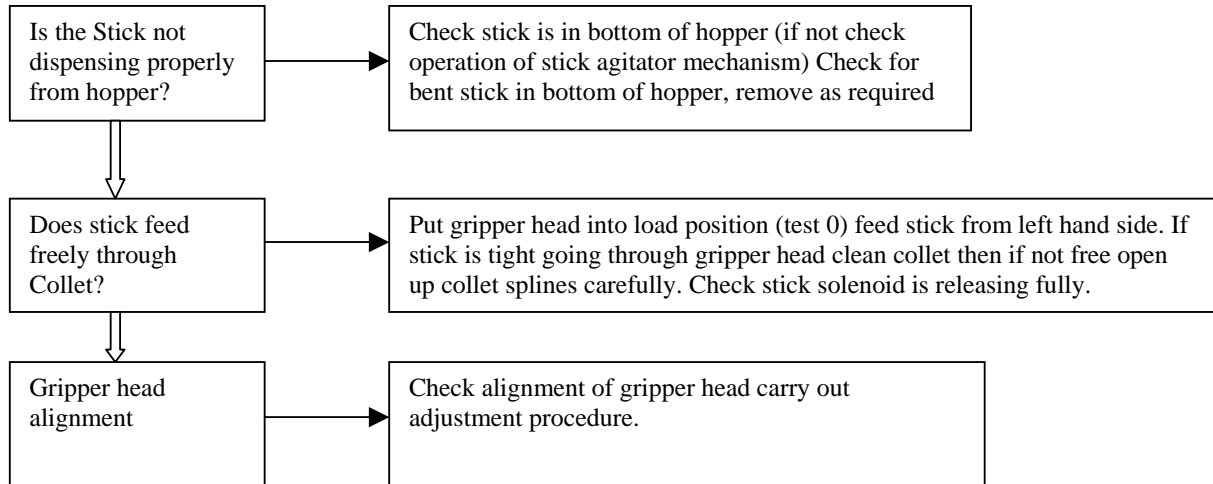

11(p)

Gripper Head Not Retuning To Vertical Position Following Stick Feed

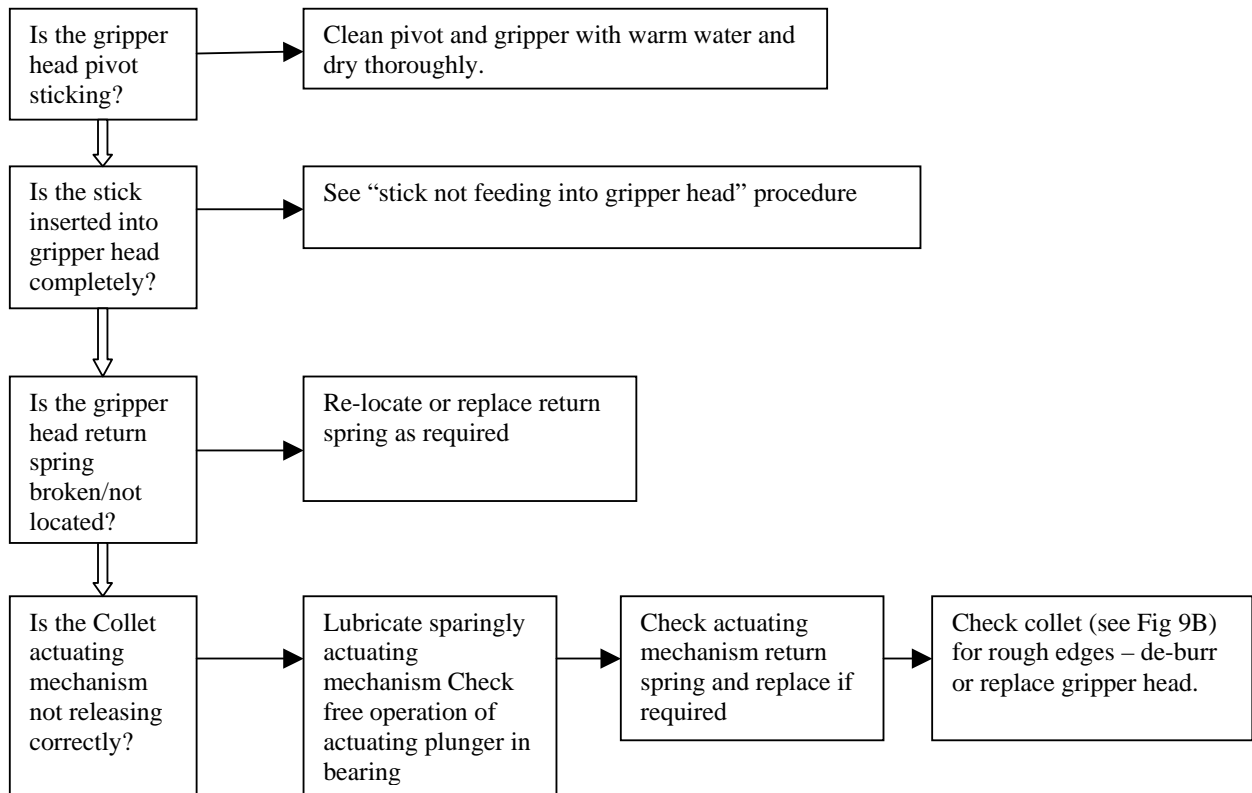

11 (q) Dropping Sticks

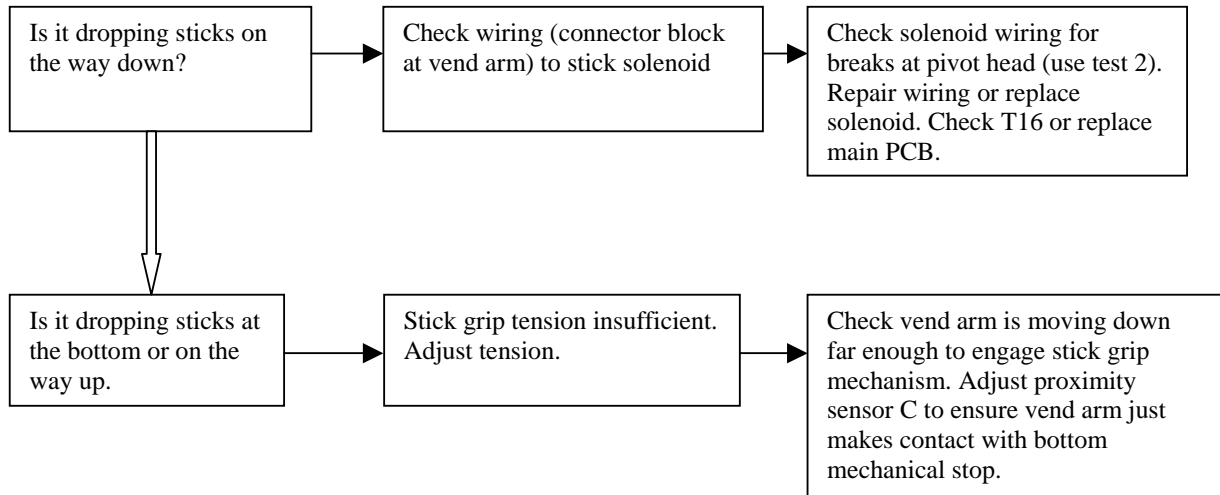

11 (r)

Burning smell or excessive Smoking

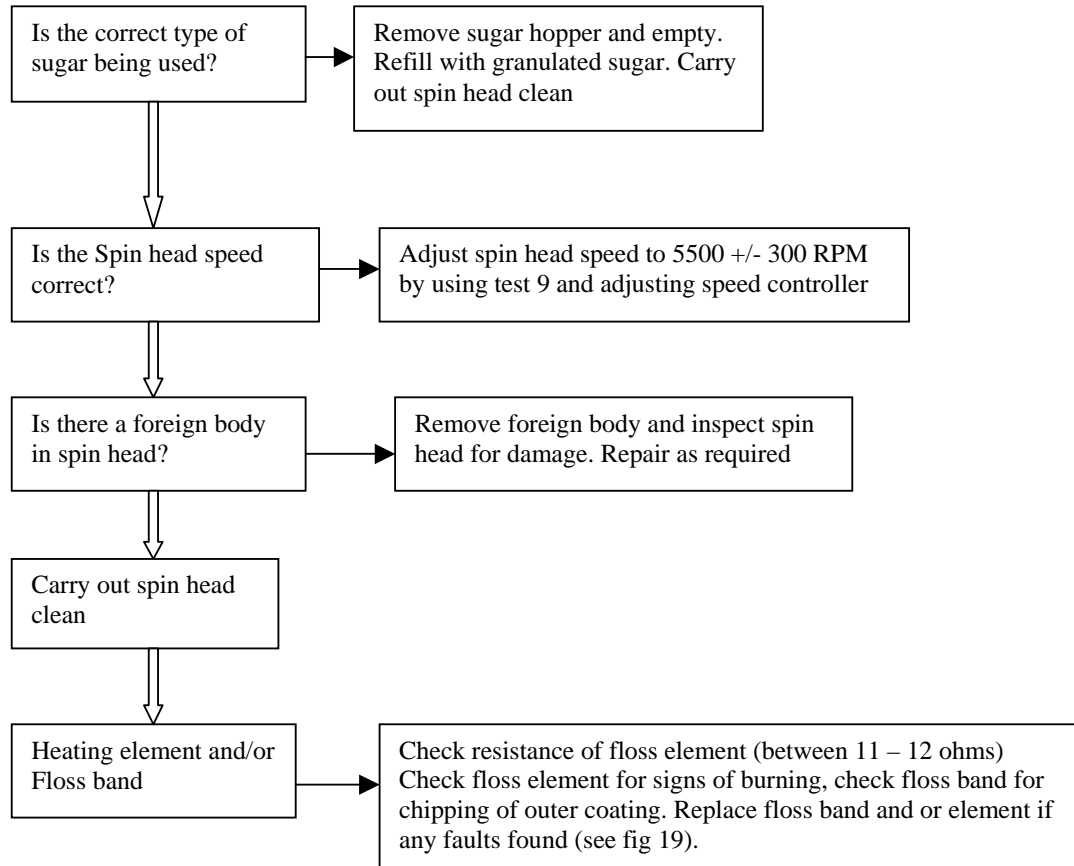

12

MECHANICAL ADJUSTMENTS

The up & down movement of the central apparatus which collects and feeds the 'paper stick' is controlled by an induction motor driving a chain. The direction of motor rotation is reversed by application of the drive voltage to alternate ends of the motor winding; i.e. the application of the drive voltage to one end drives the motor up whereas application to the other end drives the motor down.

The motor is stopped precisely by the joint action of removing the drive voltage the vend arm coming to rest against the mechanical stops.

For manual movement of the vend arm rotate the vend arm motor shaft by hand.

PROXIMITY DETECTORS

The signals indicating the stop positions for the gripper head are provided by the proximity detectors marked A, B, & C on Fig 5 . These are activated by a magnet. These are factory set and normally require no adjustment.

There are three important positions for the gripper head to reach, which require periodic checking to ensure trouble free operation: these can be checked and readjusted by using the test procedures in section 8A

Pre-setting checks and adjustments

CHAIN ADJUSTMENT

The chain can stretch with repeated use and could eventually cause improper alignment, particularly at the point of stick feed and swinging arm engagement.

Ideally the chain should have about 10mm of flex when pressed inwards in the center.

To tighten: loosen the 6 screws, 3 on either side of the top of the central column (fig 7) with an Allen Wrench, then turn the 2 top screws (10mm hex) on either side of the chain in a clockwise direction an equal amount.

Tighten the 6 screws (3 each side) once again with an Allen Wrench. **DO NOT OVER TIGHTEN THE CHAIN.**

Setting stick holding tension

Wind down the vend arm approximately 2 inches from the home position using the protruding vend arm motor shaft to the left of the control panel.

Remove the LED panel from the front of the vend arm by removing the 2 screws and disconnecting the wiring connector.

Feed 60mm of the stick into the gripper head from underneath.

Operate the locking mechanism by gently pushing down by hand until it engages.

The stick should be gripped just as the locking mechanism engages.

The stick should be held firm enough so it requires a gentle pull to remove it from the gripper head.

NB. The gripper head tension needs to be sufficient to hold the stick firmly whilst making the cotton candy, and to lift the cotton candy from the bowl even if it contacts the vend chamber on the way up. On the reverse ensure that the tension is not too great, this can be checked by looking at the paper stick where it is held by the gripper head. No marks or tears should be left on the stick.

To lessen the gripper head tension, loosen lock nut and set screw (fig10a). Screw in adjusting wheel (fig 10a item 4) counter clockwise (looking from the top) a quarter of a turn and re check tension. Repeat this operation until the tension is correct. Tighten set screw and lock nut.

To tighten gripper head tension, loosen lock nut and set screw. Screw out adjusting wheel clockwise (looking from the top) a quarter of a turn and re check tension. Repeat this operation until the tension is correct. Tighten set screw and lock nut.

The stick should drop out of the gripper head under its own weight when the engage arm fig10a item 2 is released and there should be no evidence of the stick being marked by the gripper head.

Stick feed position (see fig 7)

Ensure the top mechanical stop is backed off sufficiently to allow the following steps.

1 - Move the vend arm upwards by hand, using the protruding motor shaft, (fig 12 item 9) until the gripper head has moved through 90deg and the middle of the gripper head is aligned with the stick exit point of the hopper.

2- Ensure the pivot rod (fig 7 item 3) is long enough to compress the spring loaded plunger by 1-3mm pushing the gripper head against the pivot arm stop.

3-Insert cotton candy stick from the left hand side of the gripper head.

4- The stick should slide perfectly from the gripper head to the stick hopper with no resistance or binding. The stick should be horizontal and level with the aluminum bar in the stick hopper.

Adjustments

The pivot rod may be lengthened or shortened using the adjuster, see fig 7 item 4.

Use the gripper head angle adjusting screw to align the gripper head horizontally fig 9 item 3.

The stick hopper can be moved backwards and forwards by loosening the 4 retaining screws underneath the shelf, to achieve the required alignment. The 2 rear screws are accessed through holes in the lower cover.

Pull the stick out from the left hand side of the gripper head and check that it is aligned in the middle of the slot cut out in the shelf to allow the stick to pass through.

Tighten gripper head angle lock nut and stick hopper retaining screws.

Adjust the top mechanical stop until it contacts with the hexagon bolt head in the top of the vend arm assembly. Tighten the lock nut. See fig 11.

Setting the lower vend arm position (see fig 10a and 10b)

Enter test 3 - The gripper head takes up a vertical position and moves downwards until stopping at a point within the bowl for the floss pick up. The bottom of assembly should now be ideally between 10mm from the shelf and the stick grip mechanism should be engaged. It is important that the engage arm is in the locked (engaged) position otherwise the stick will be dropped when the gripper head is withdrawn from the bowl.

Adjustments

- 1 - Move the vend arm by hand to approximately half way through its downwards travel.
- 2 - Cut a stick 80mm long, wrap 2 times around with masking tape around one end and insert into the Gripper head 60mm from the right hand side, and tape last. (This device stays in the gripper head for the remainder of the set up procedure, and is to stop the gripper head from distorting when being operated whilst setting the lower stop).
- 3 - Move the vend arm down by hand until the lower mechanical stop comes into contact with the shelf. At this point there should be a 10mm gap between the vend arm retaining block (fig 10b item 5) and the shelf. The lower mechanical stop is a hexagon screw with a locknut. This should be preset to 10mm and should not require adjustment.
- 4 - With the vend arm in this position adjust the engage arm adjuster (Fig 11b) by loosening the M8 locknut (13mm wrench), and turning the adjuster from underneath the shelf (screw driver slot), until the engage arm detent just moves to the locked position. Turn the height adjuster one more turn clockwise (looking from underneath) from this position and then tighten the locknut. Check from the front that there is 1 to 2mm gap between the engage arm detent (Fig 10a item 1) and the engage arm (Fig 10a item 2).

NB. When stick is held by locking mechanism and turning it should be possible to apply gentle pressure with your thumb and finger to the stick and the stick to continue to rotate and start to slow the rotating motor down but not stalling it)

Setting the home position See fig 8 & 11

- 1 - Set the home position proximity detector B so that the vend arm stops just after the engage arm mechanism is released and the stick is dropped.
- NB** A rough guide of this position is the centerline of the stick solenoid is just below the top face of the shelf or the centerline of the engage arm detent bearing is 4mm below the centerline of the detent strike stud.
- 2 - Adjust the detent strike stud (Fig 8 item 1), held by M6 nut (10mm wrench), as far to left as possible but still releasing the engage arm in the home position.
 - 3 - Check for a 1 to 2mm gap between the pivot rod and the spring loaded plunger. Adjust the length of the pivot rod if required.
 - 4 - Tighten proximity sensor B.

Setting upper and lower proximity detectors

- 1 - Operate the vend arm to the load position. (test 0) The vend arm should stop just before reaching the top mechanical stop. Mark the position of the sensor as a reference.
- 2 - Move the proximity detector A upwards in small increments, operating the vend arm between each movement to the load position (test 0), until the vend arm stops electrically just as the hexagon bolt head comes into contact with the top mechanical stop.
NB The motor should not drive the vend arm hard into the top stop but it should come rest against the stop each time.
- 3 - Tighten sensor lock nut.
- 4 - Carry out the same procedure to adjust the lower proximity sensor C.

13.

Fig 1. Front View.
Door open, bowl and bowl lid removed.

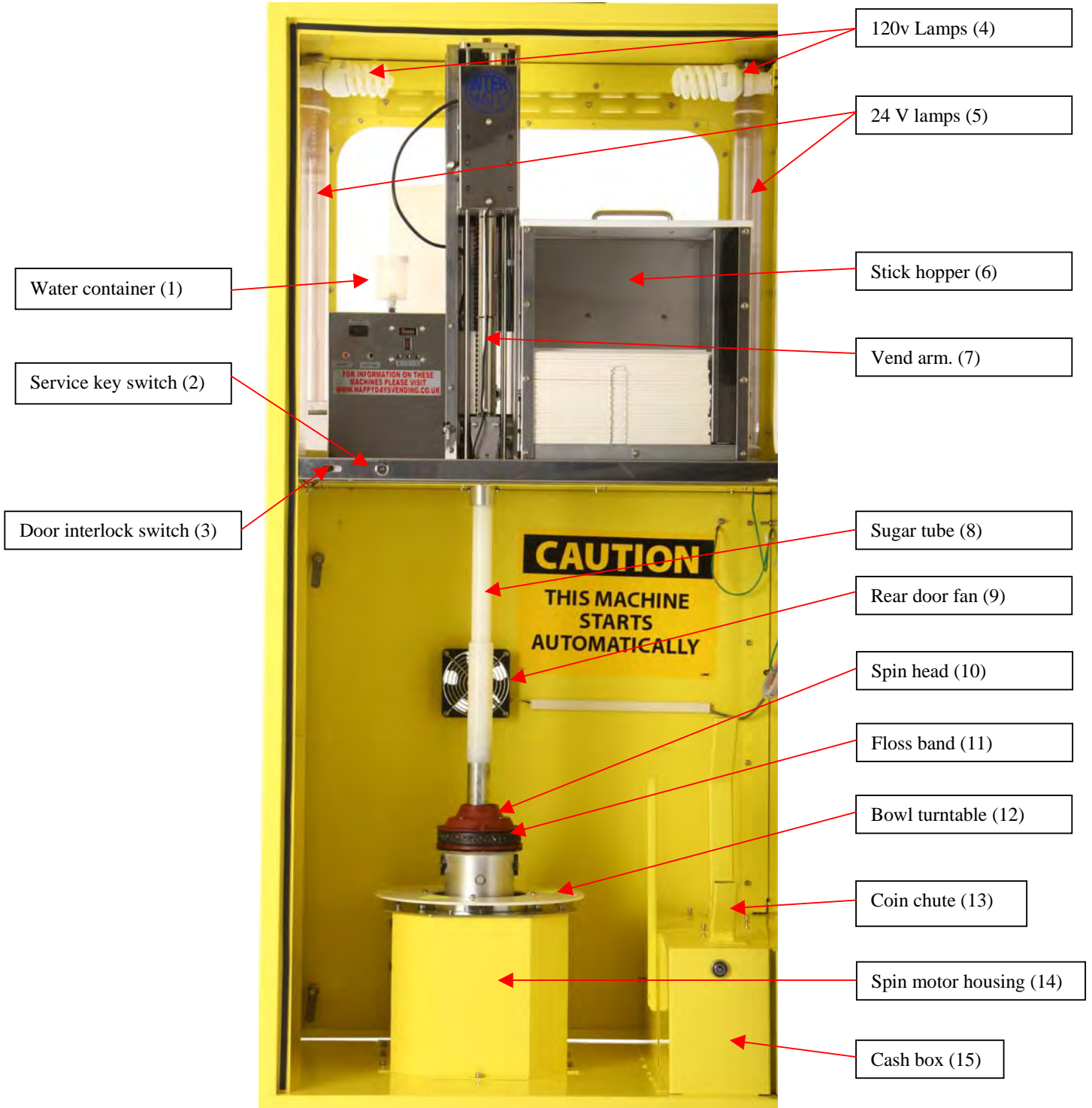

Fig 2. Rear View.
Door open, electronic enclosure lid removed.

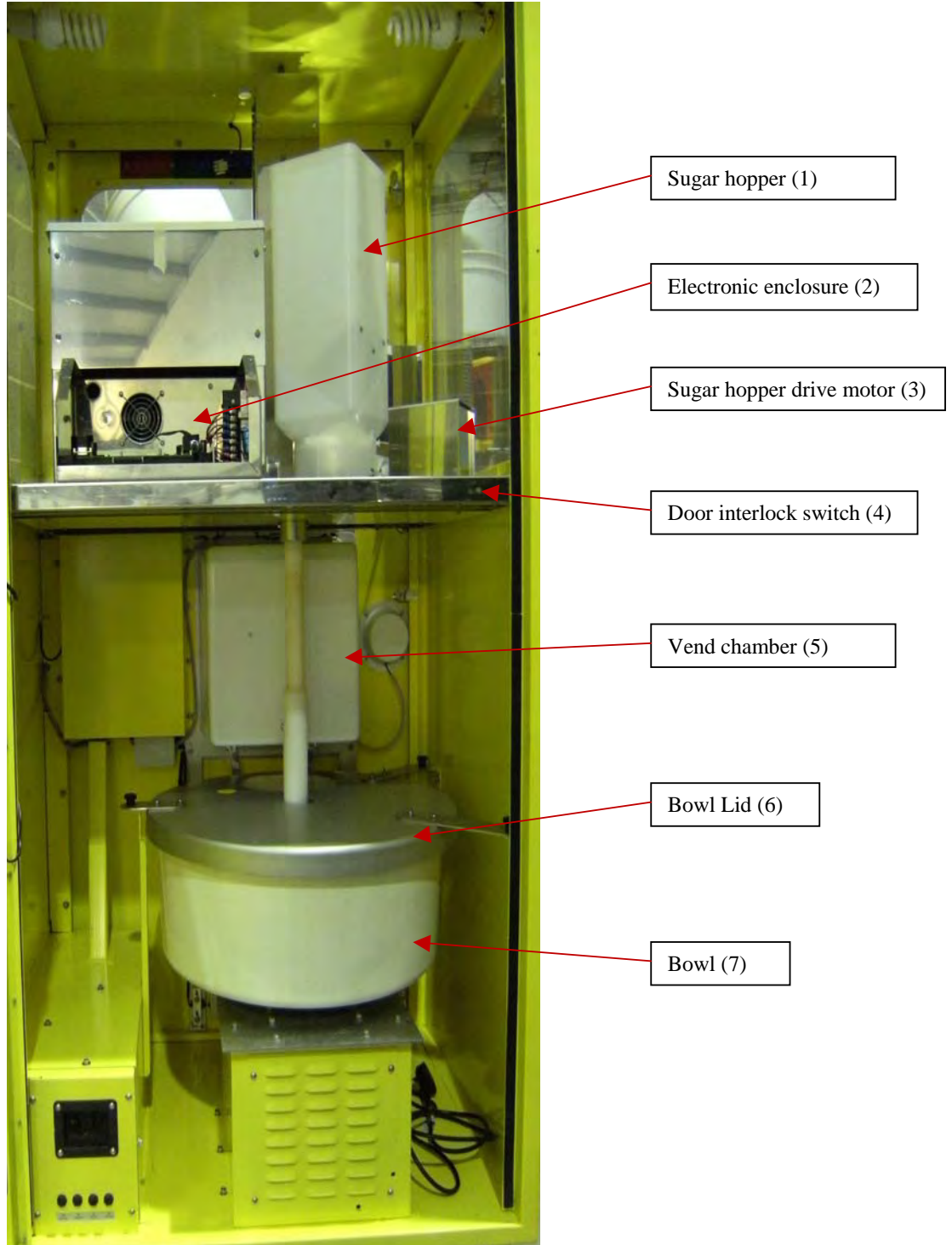

Fig 3a. Rear lower view.



Fig 3b. Transformer enclosure.

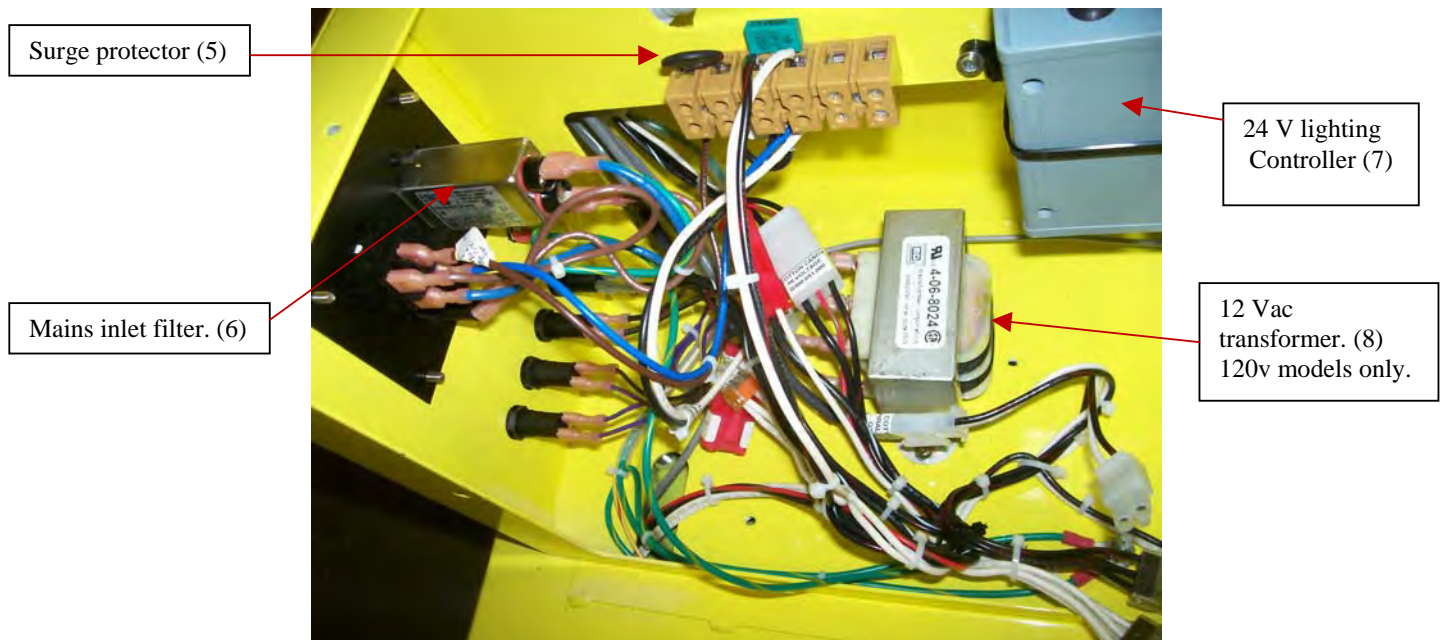

Fig 4. Inside front door.

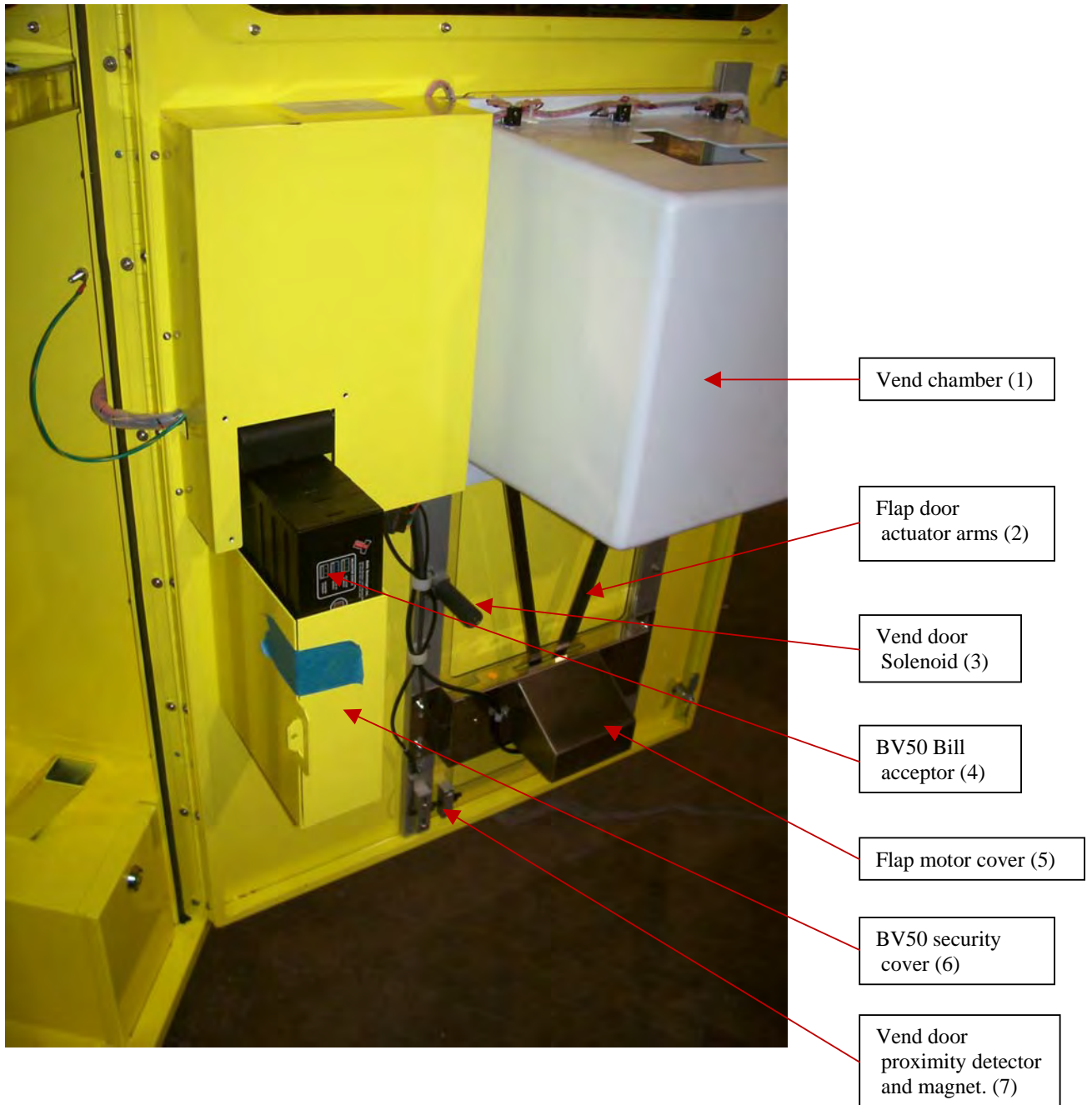
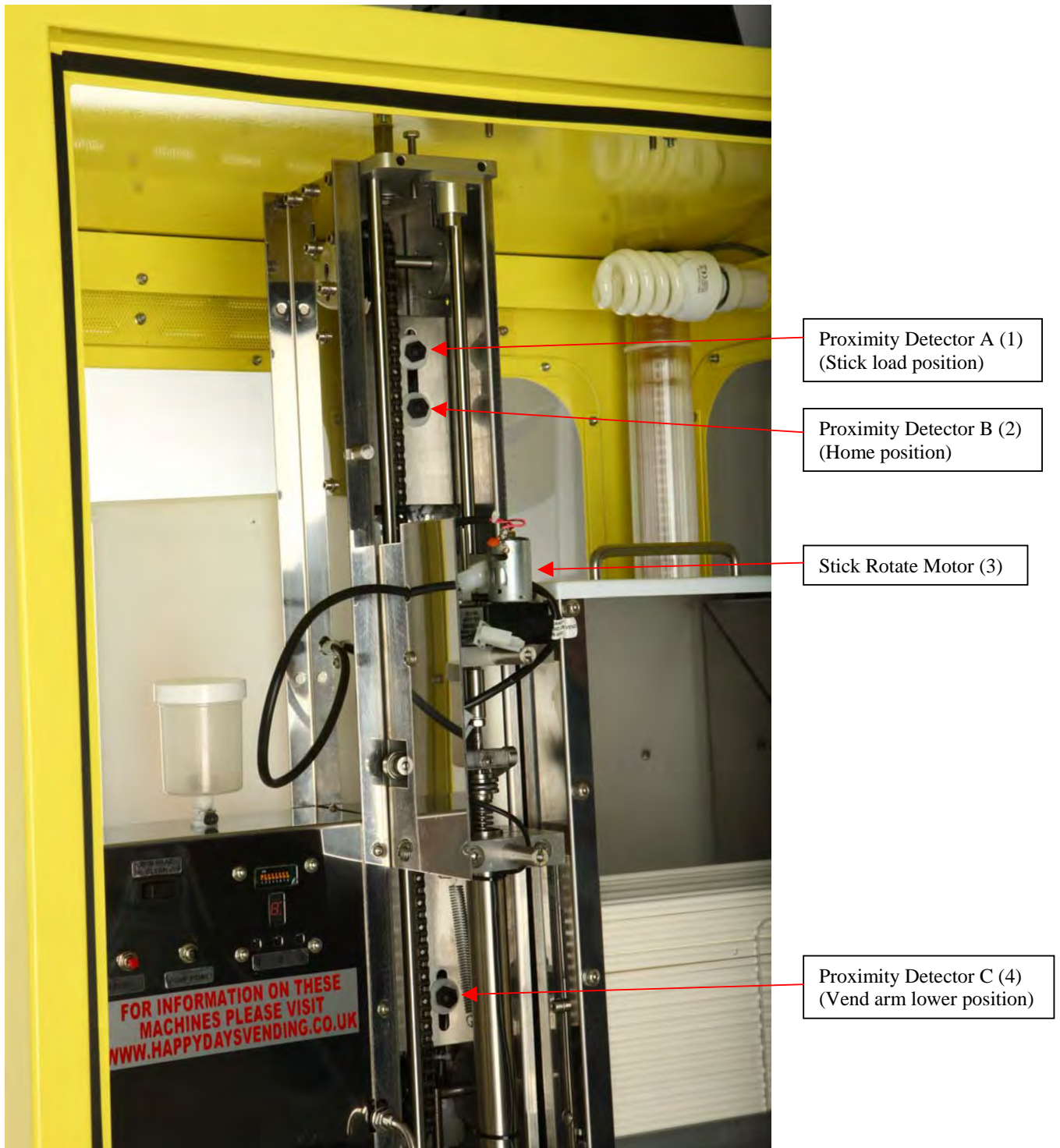

Fig 5. Vend assembly.



Vend Arm Pause Detector

Machines built after November 2010 will have an additional detector fitted to the vend assembly. This is to allow for accurate adjustment of the “pause” position. This is when the vend arm stops momentarily to allow the flap doors to close before continuing to the home position

Fig5a.

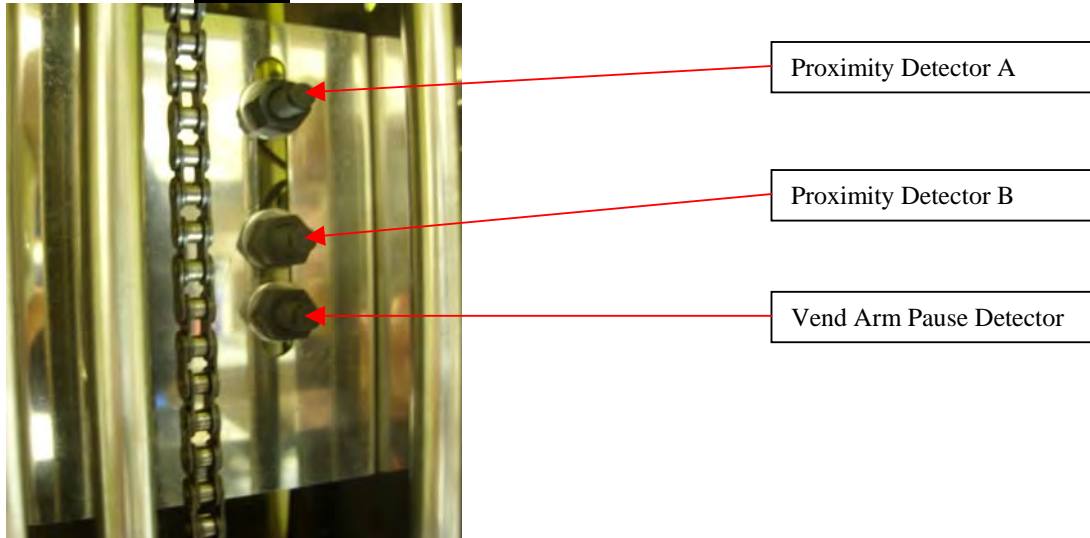

HOME POSITION

Fig 6.

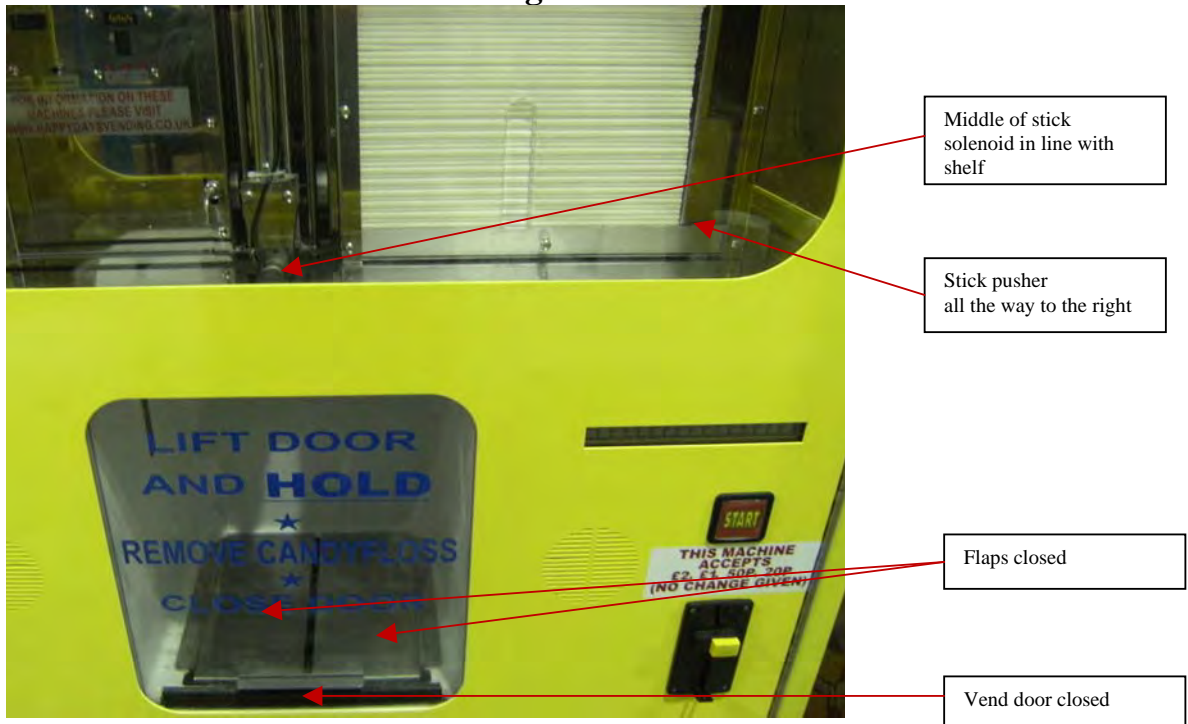

STICK FEED POSITION

Fig 7

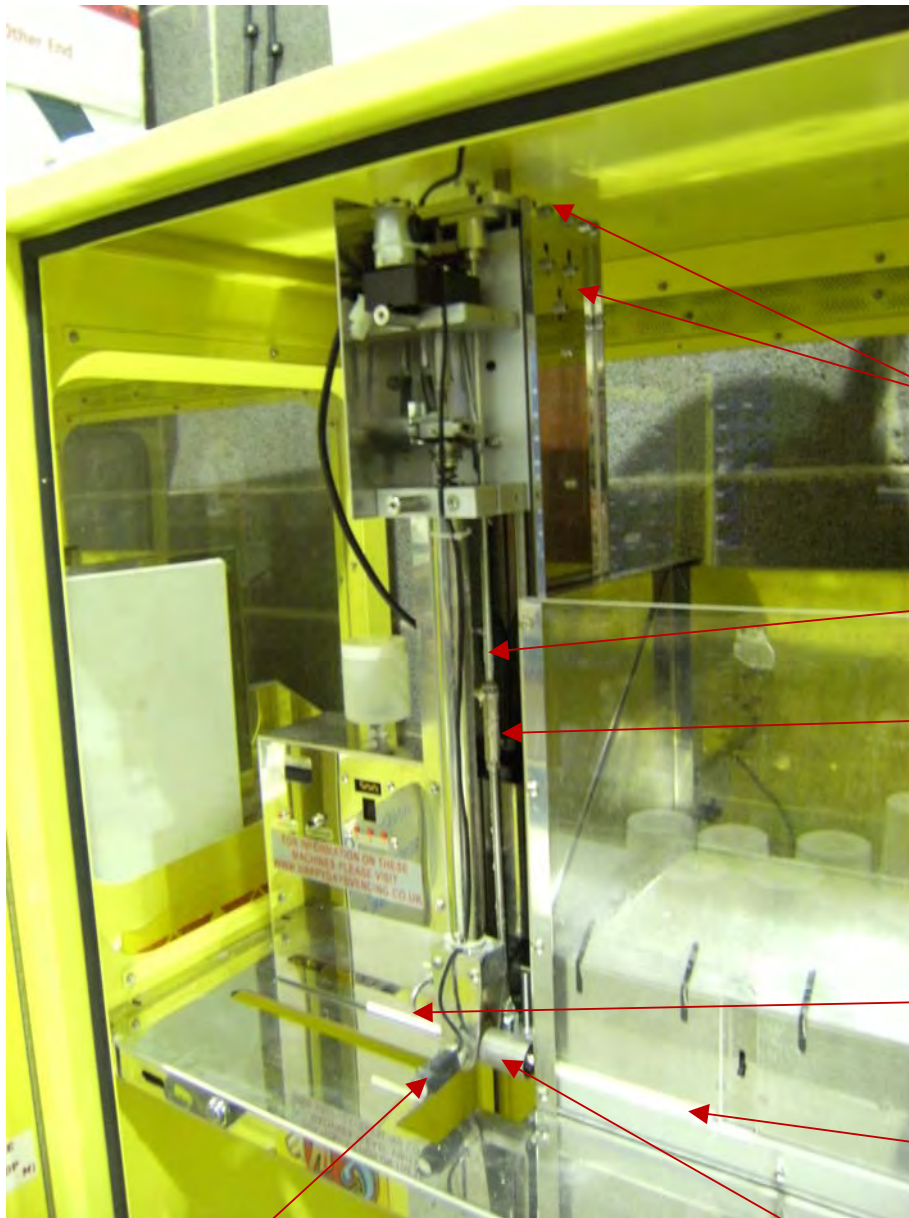

Vend arm chain adjusting screws (same on the other side) (2)

Pivot rod (3)

Pivot rod length Adjuster (4)

Gap of 1 to 2mm between stick and water nozzle

Stick horizontally in line with stick hopper

Gripper head (5)

Stick grip solenoid (1)

**Fig 8. Vend arm mechanism. Home Position
(covers removed)**

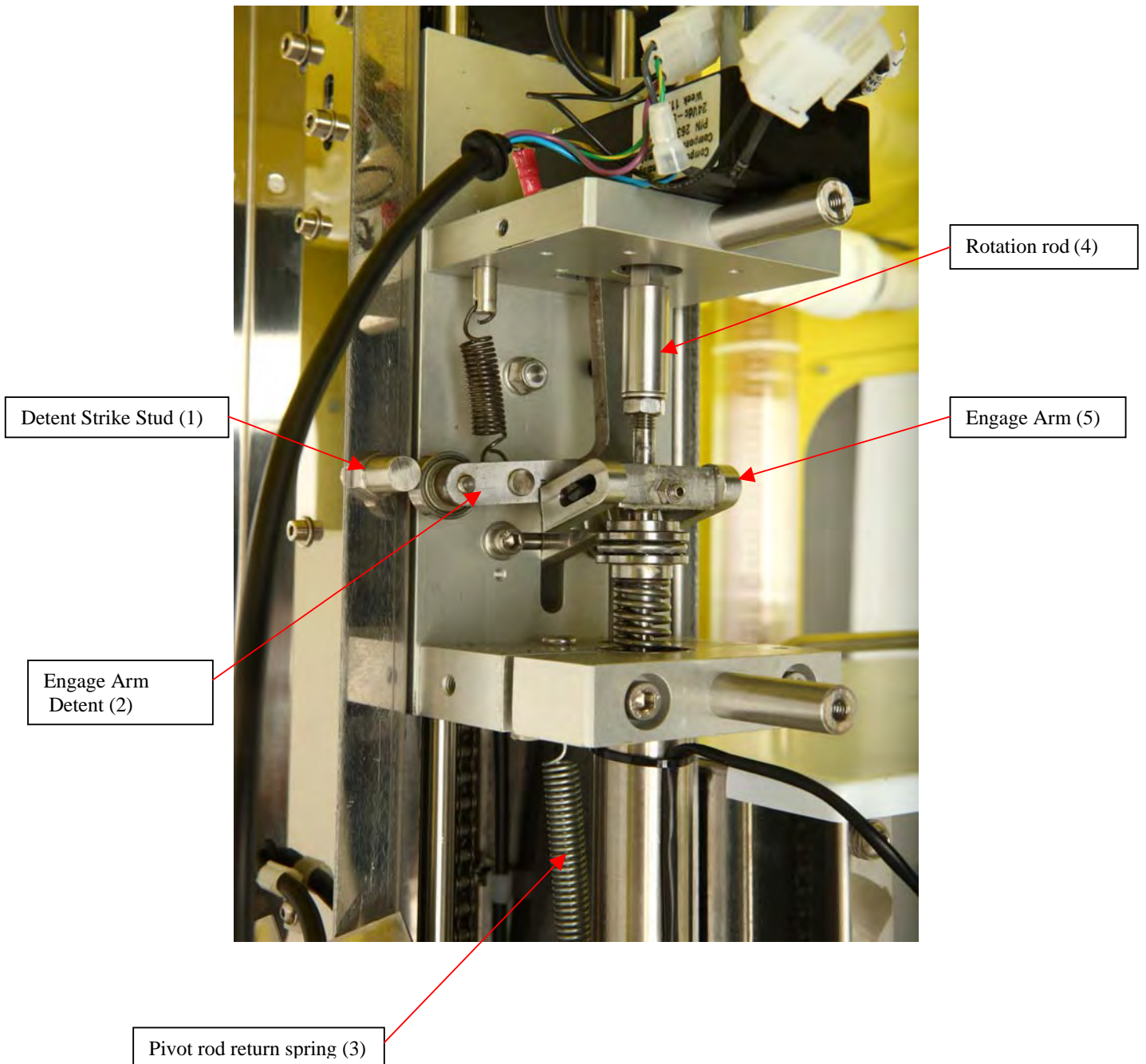

Gripper head angle adjusting screw
Fig 9a

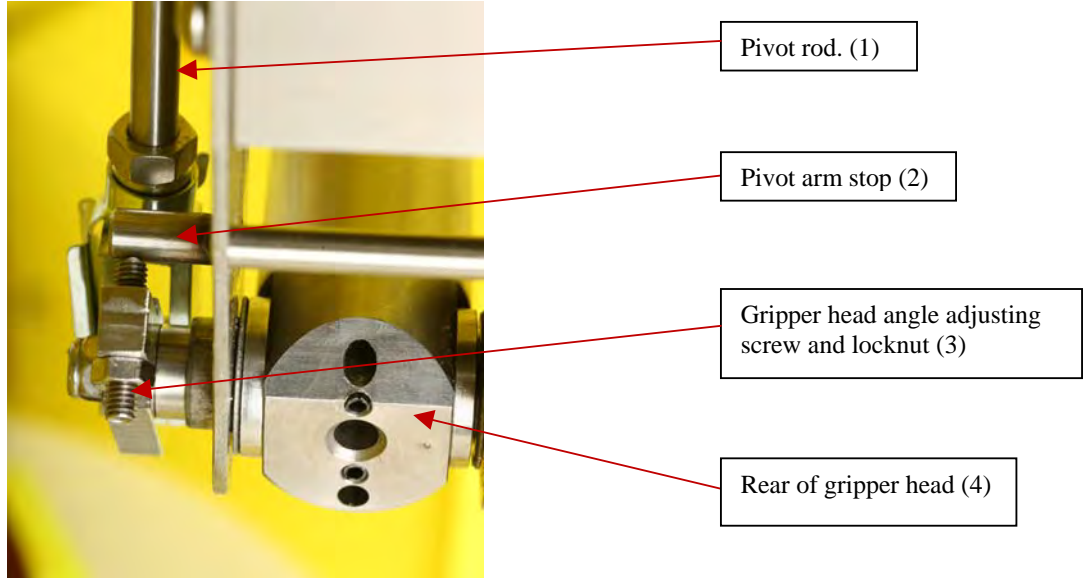

Gripper head.
Fig 9b.

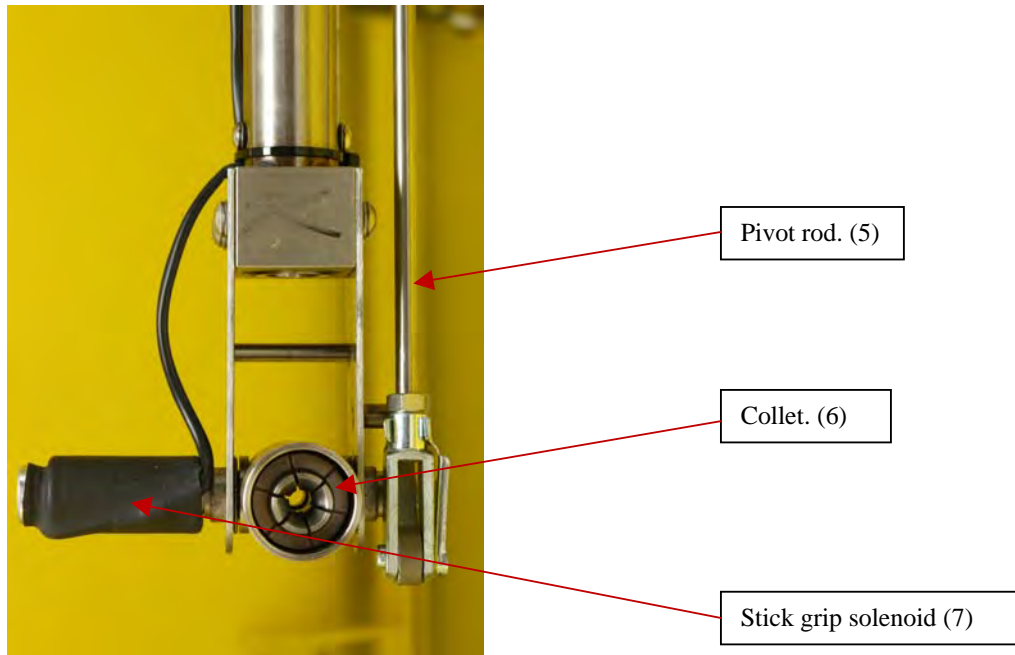

Lower Position
Fig 10a.

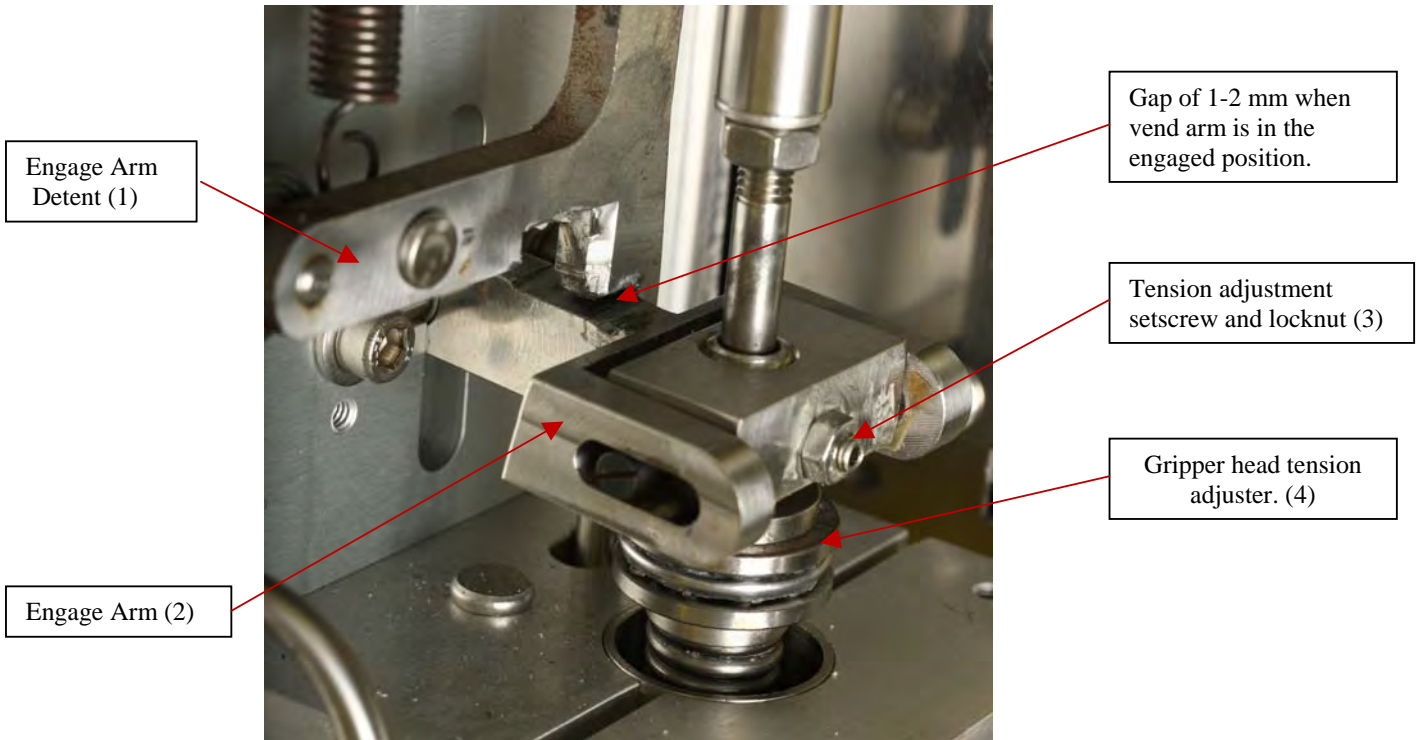

Fig 10b

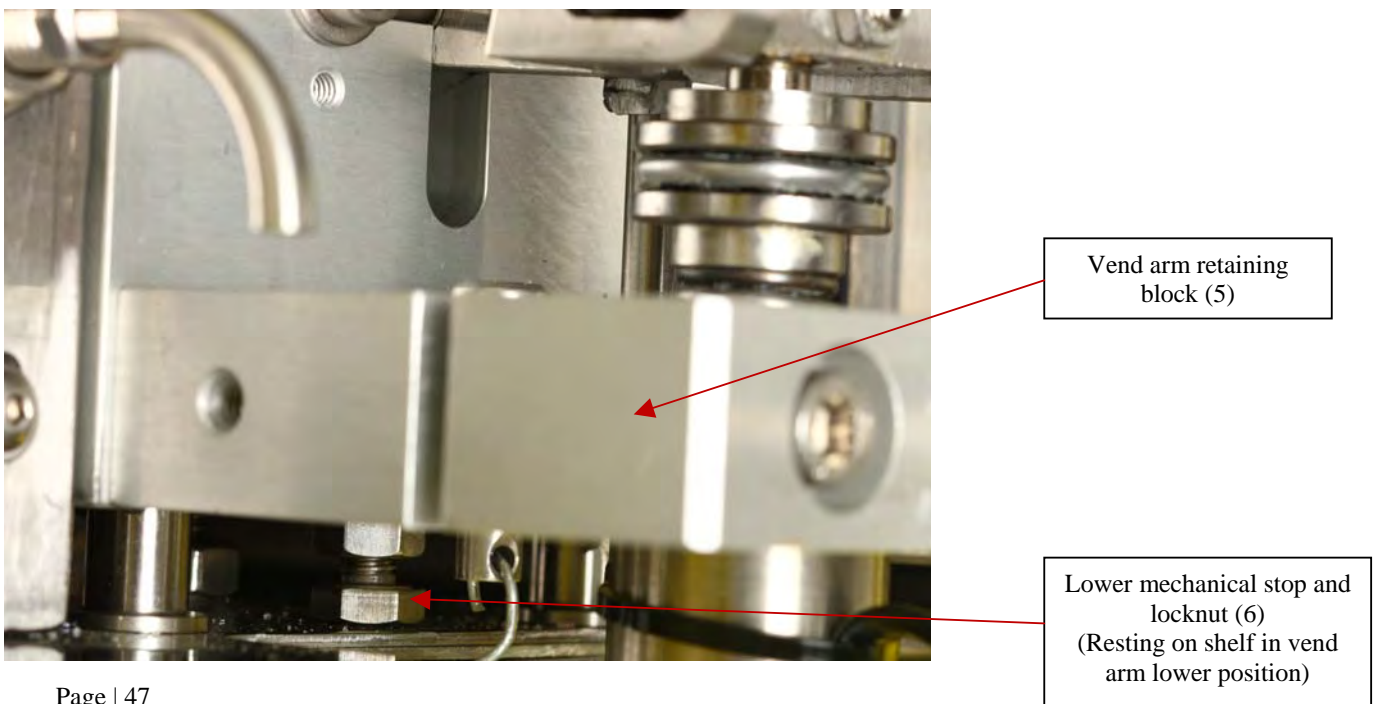

Fig 11a

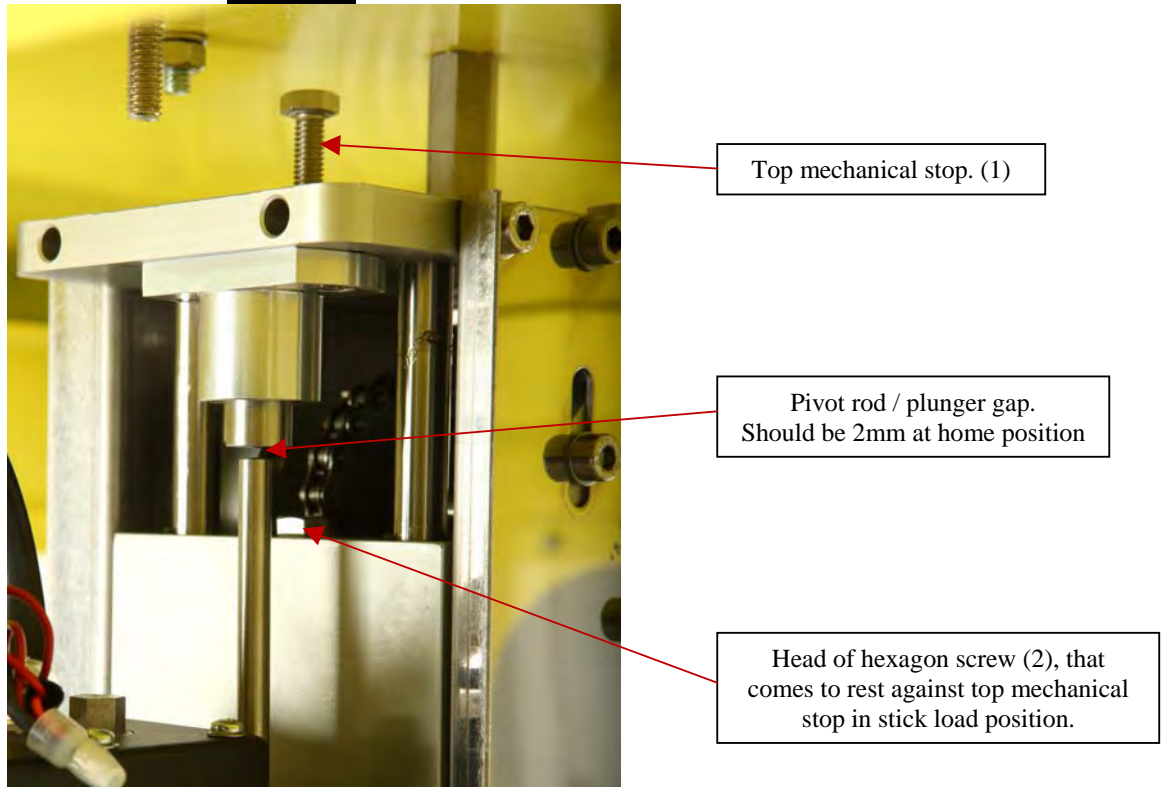

Fig 11b

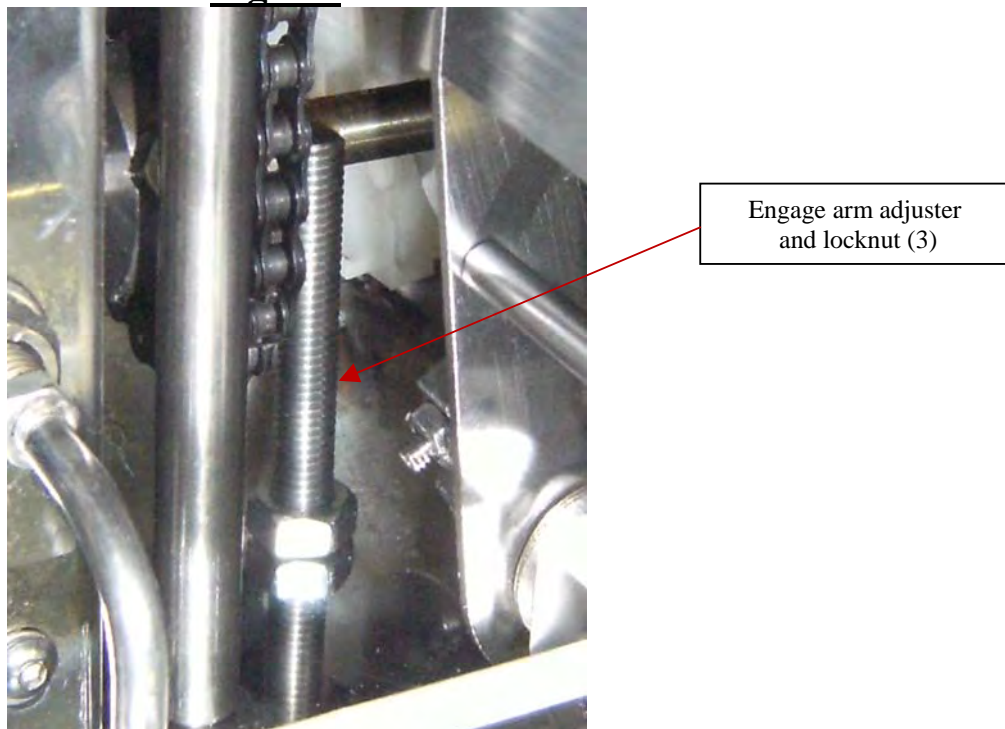

Fig12.

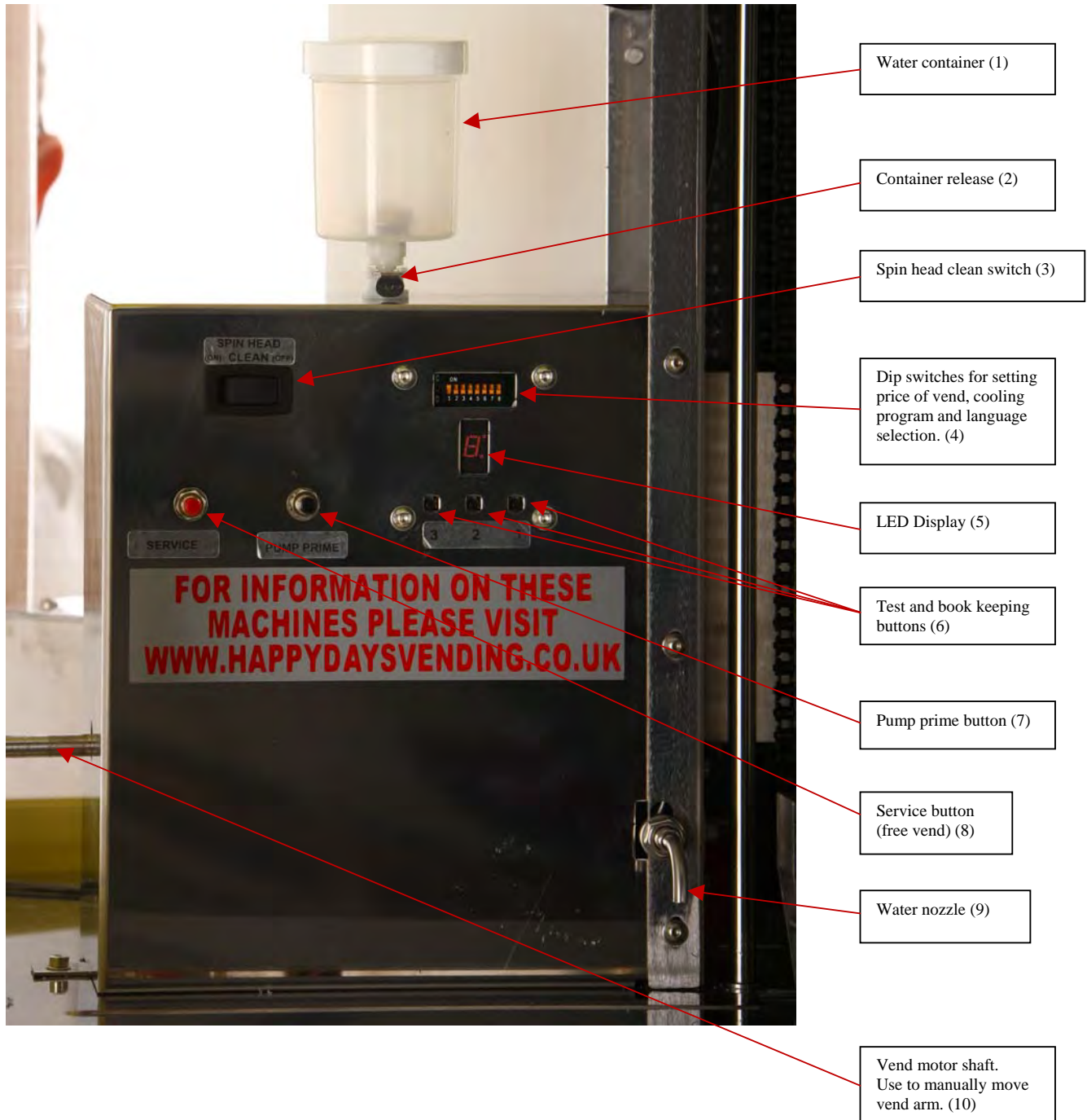

Fig 13.
VEND MOTOR REAR

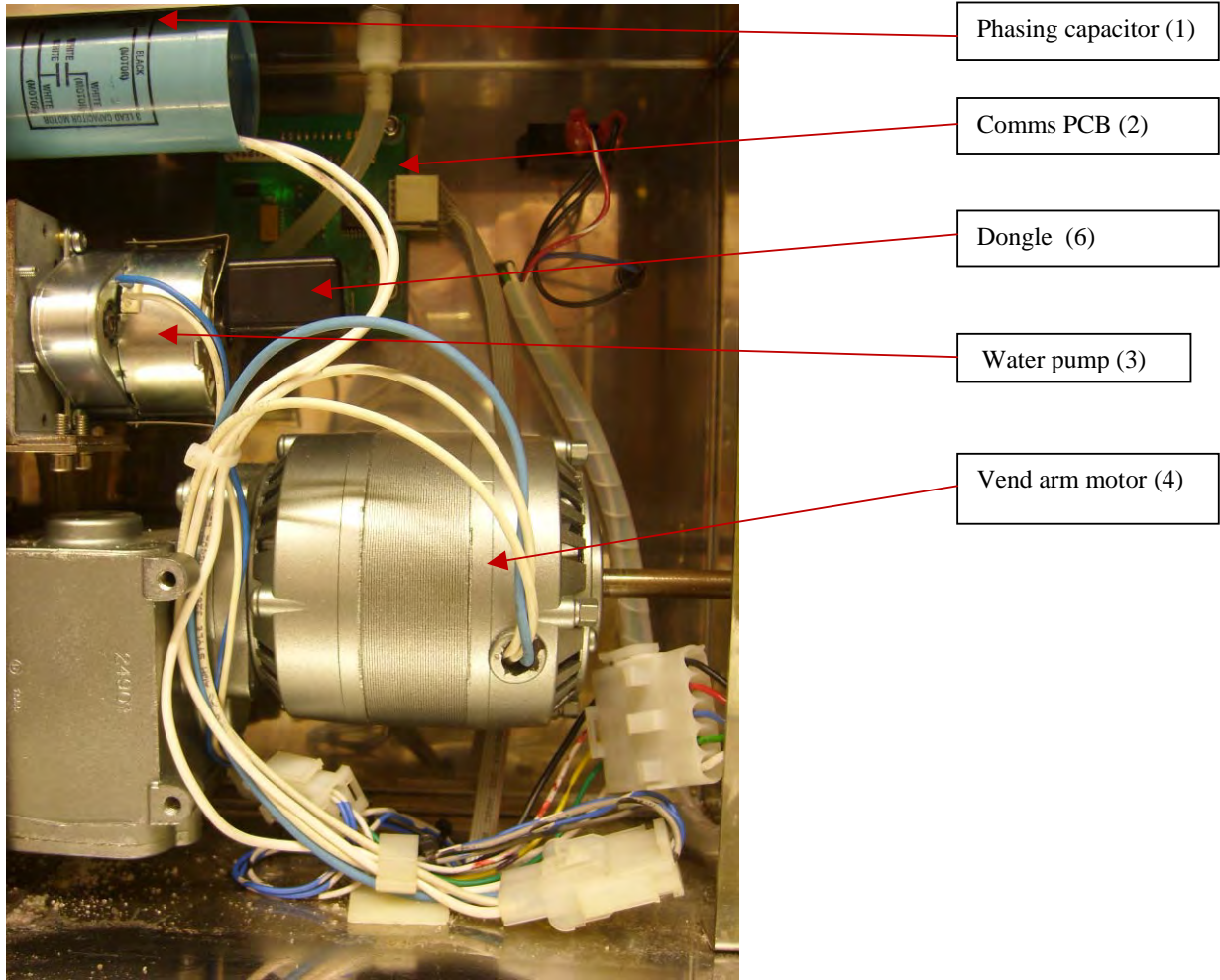

Fig 14
ELECTRONIC ASSEMBLY REAR

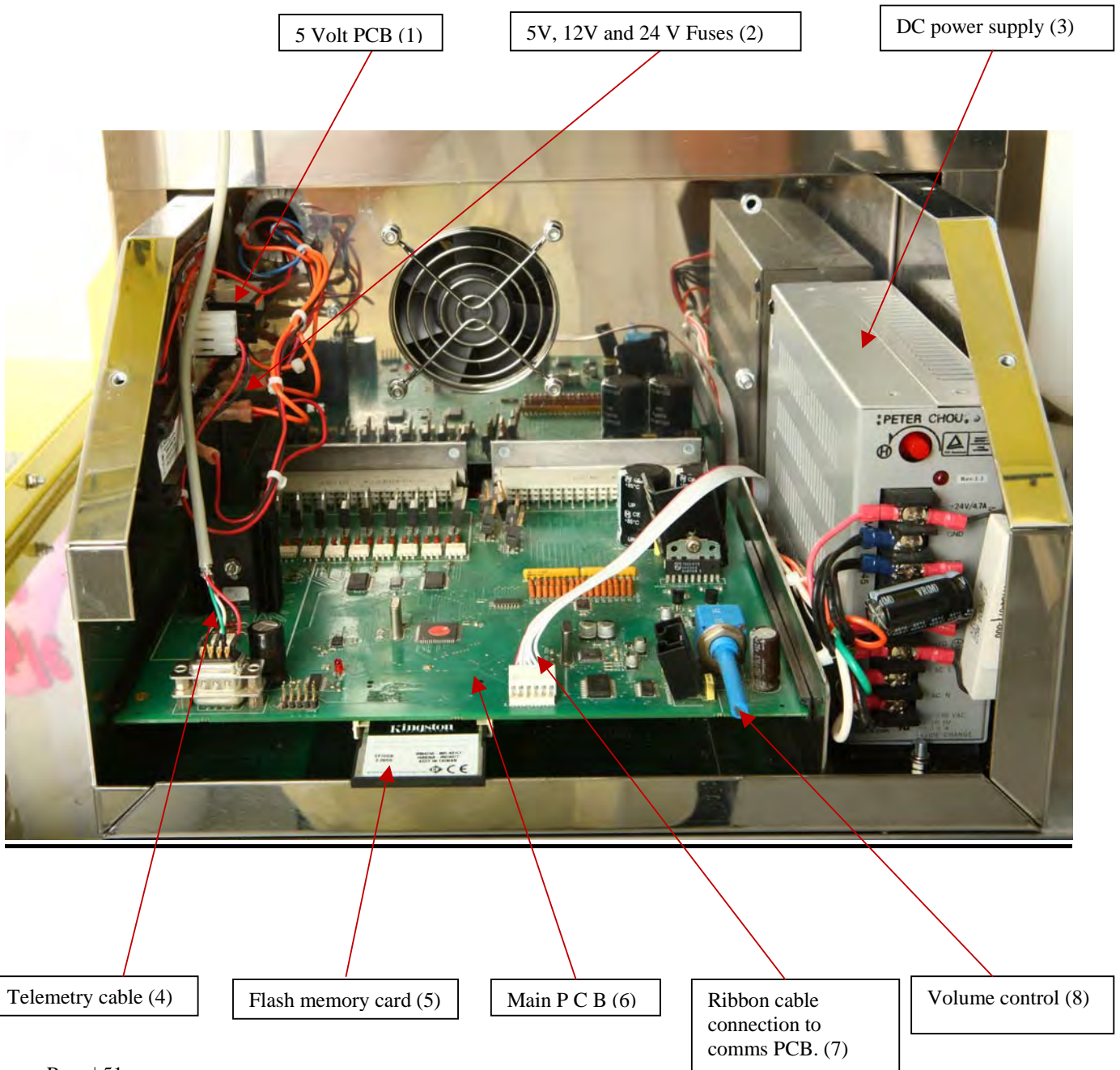
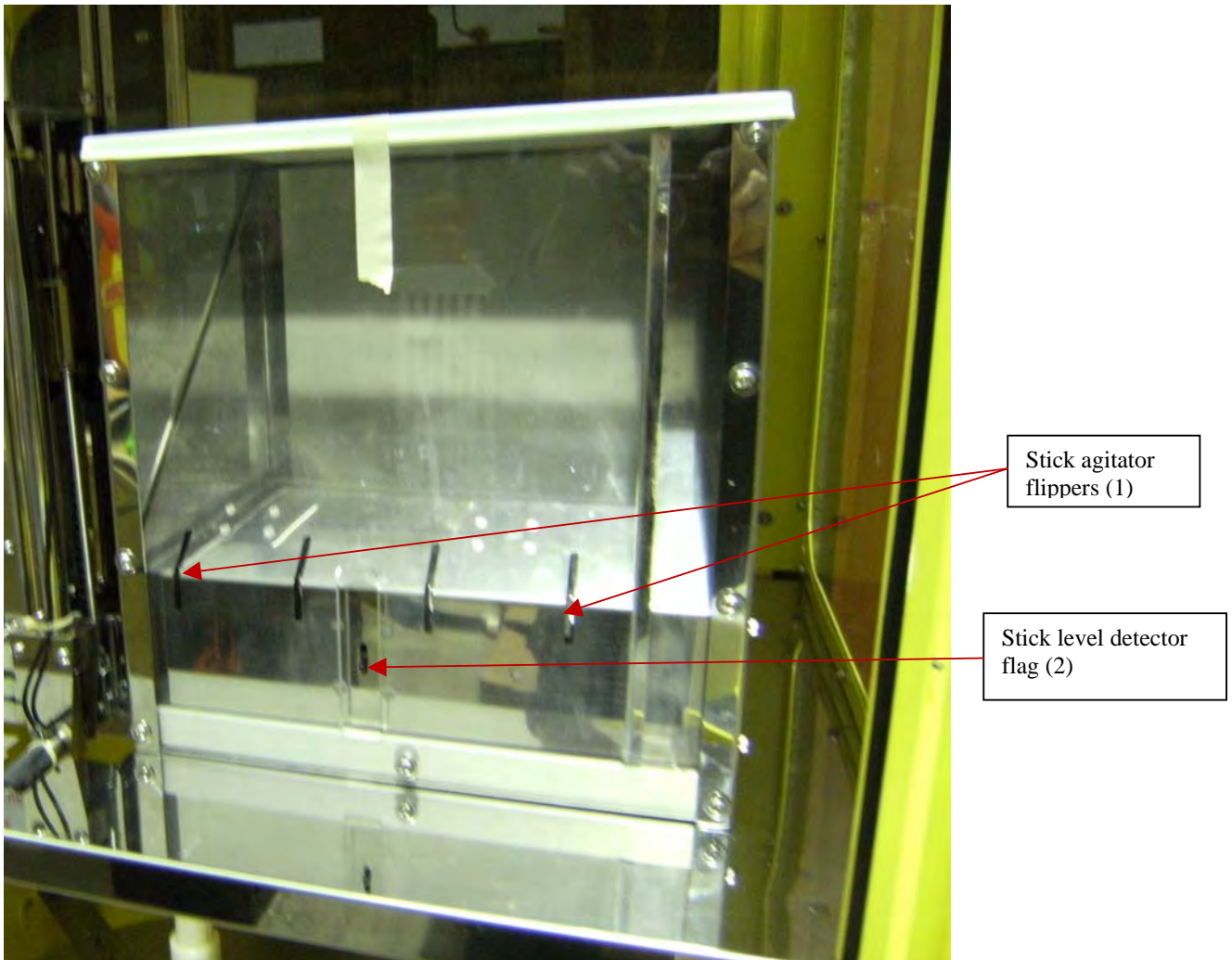
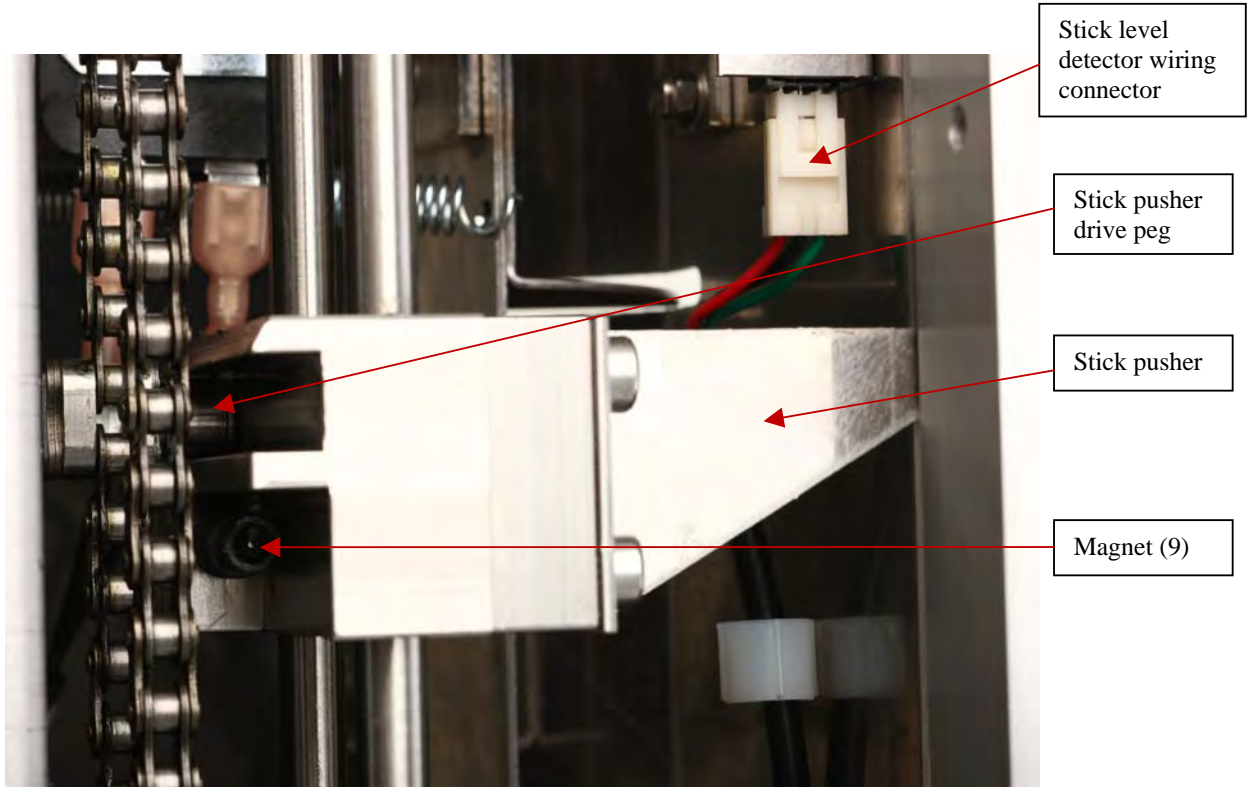
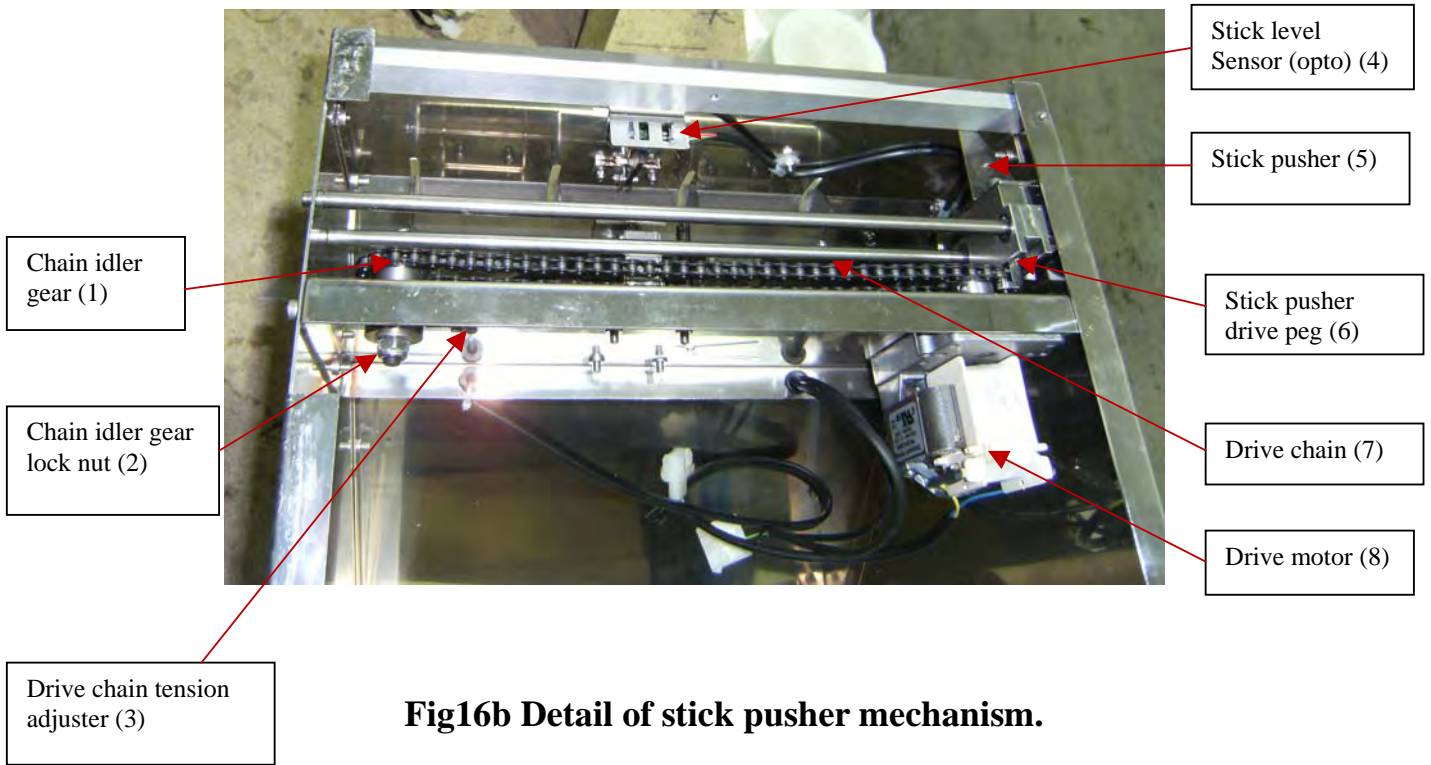

Fig 15.
STICK HOPPER FRONT



If the stick pusher drive peg comes out of the channel it can be re-located without removing the stick hopper. See Fig below. Check for any binding or obstruction in the drive mechanism. The usual reason for the pusher to be out of location is after much use the drive chain will possibly stretch and require re-tensioning. To do this loosen drive chain idler gear lock nut, loosen off the adjuster lock nut screw in the adjuster $\frac{1}{2}$ a turn, retighten and check chain tension. It is important NOT to over tighten chain tension. Ideally there should be a small amount of slack in the chain approx 5mm deflection at the centre.

Fig 16a STICK HOPPER
Viewed from underneath in the home position



Spin assembly.

Fig 17a

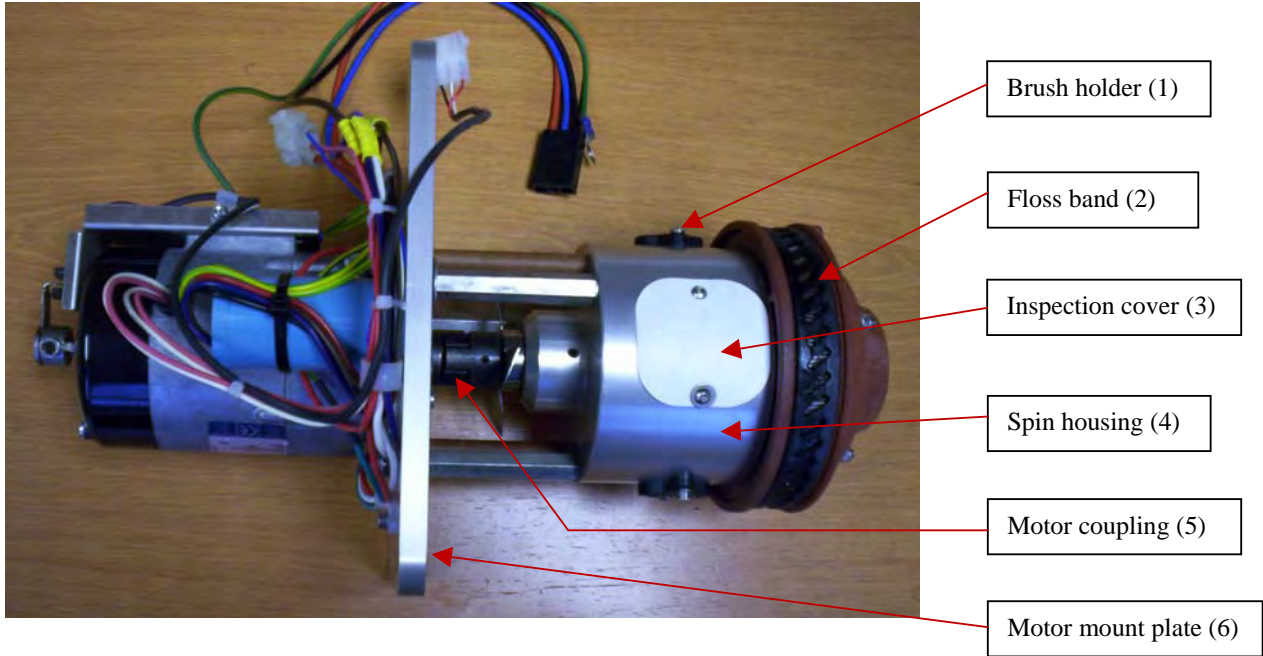

Fig 17b

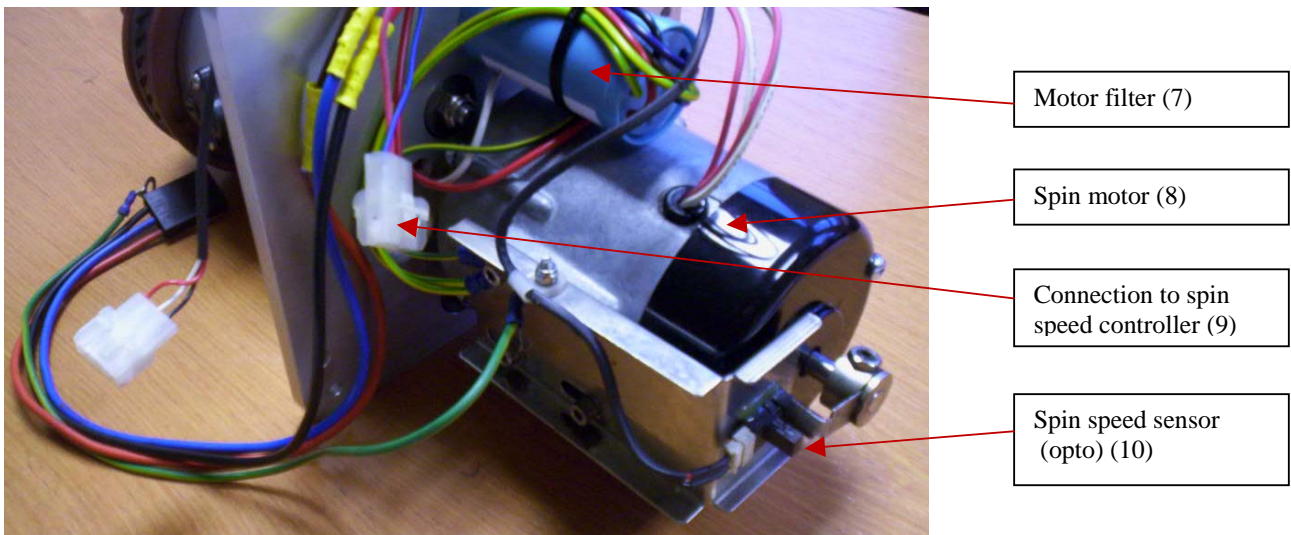

Fig 18a Spin head removed.

Components shown in order of removal.

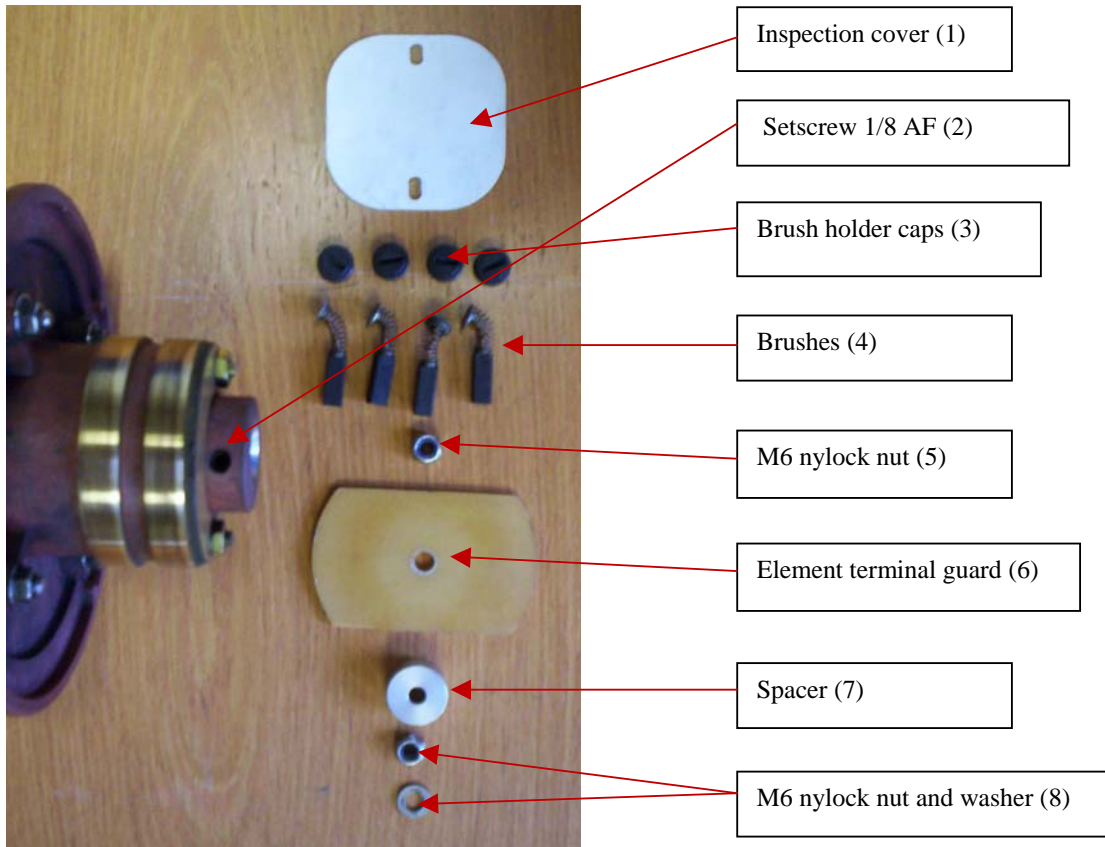
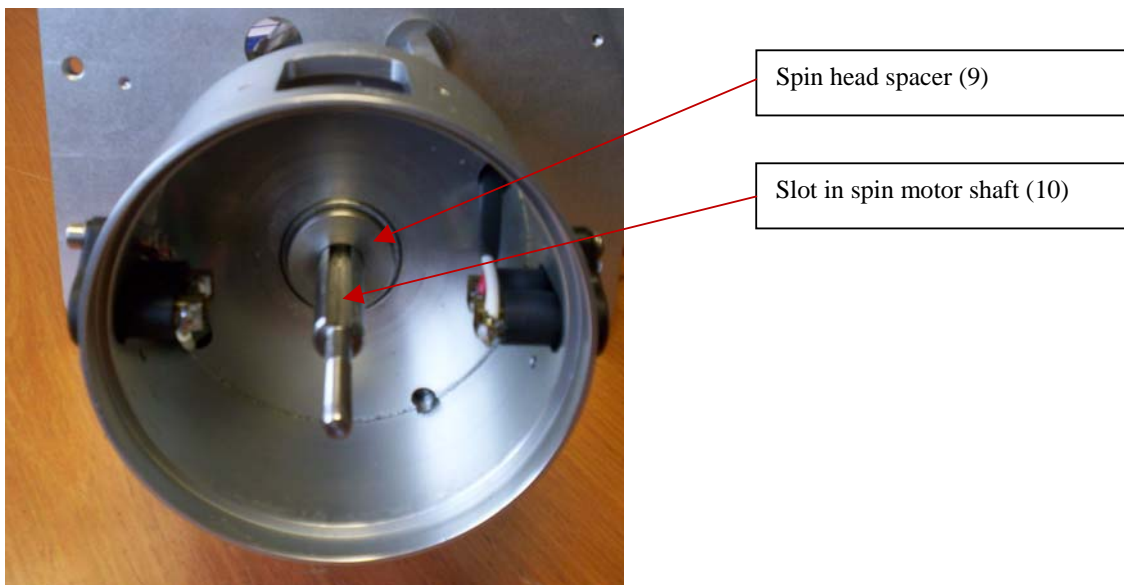

Fig 18b Spin housing and shaft.



Hall Effect Spin Speed Sensor.

In the latest version of spin motor assembly the optical speed sensor is replaced with a magnetic sensor as shown in Fig 18c below. The detector is activated by a magnet fitted to the rotating bracket on the motor shaft. The LED on the sensor will illuminate when the magnet passes over it. The magnet to sensor gap should be set to approximately 5mm.

Fig 18c

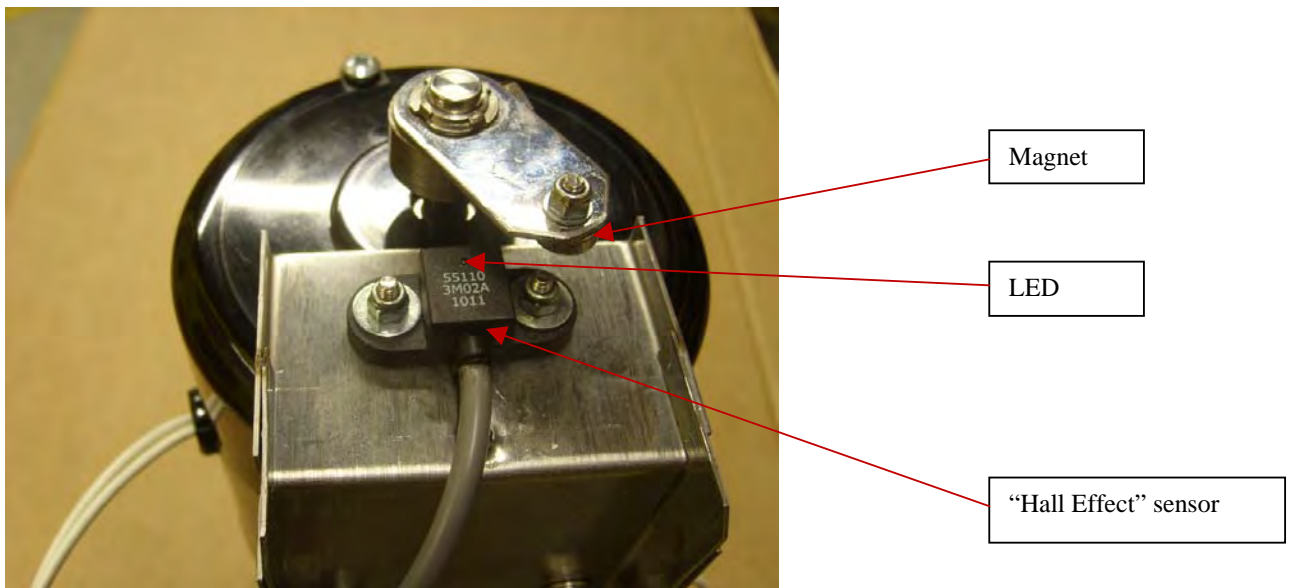

Changing The Heating Element

Fig 19a

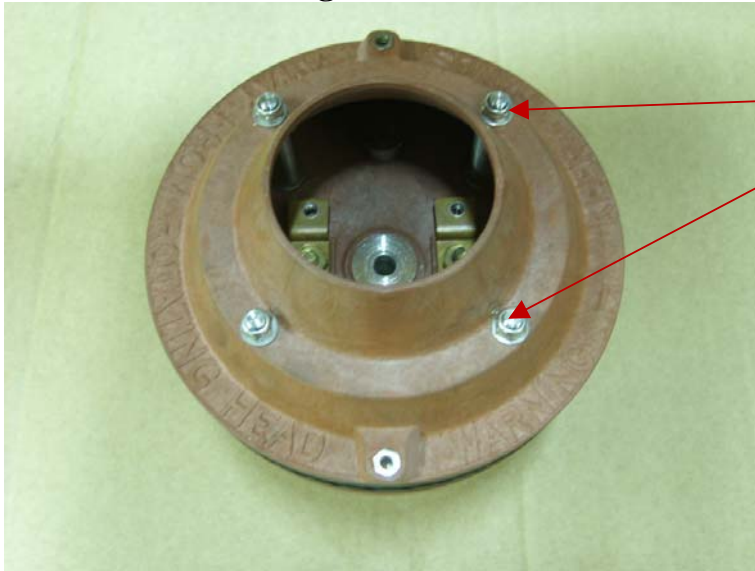

Remove 4 nuts and washers and remove the spin head top cap.

Fig 19b

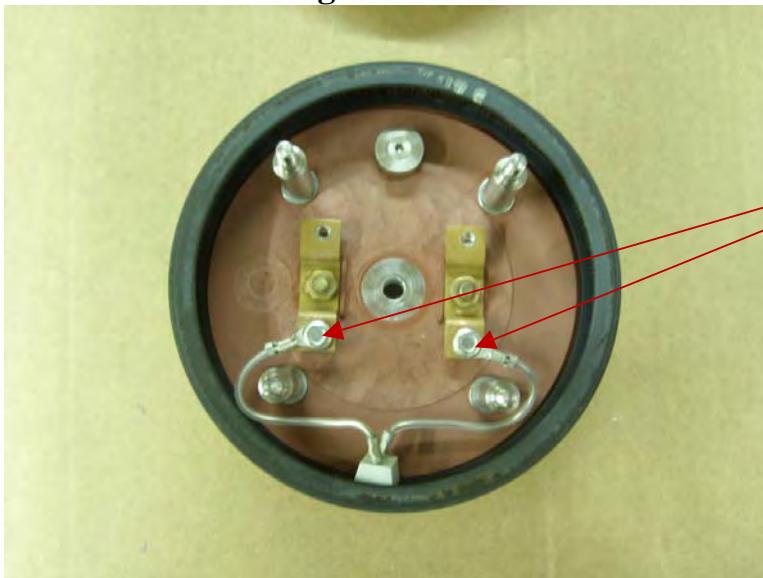

Remove element screws and remove floss band and element as one unit.

Place the floss band and element in hot water to melt the sugar and release the old element from the floss band. Check the floss band for any external chipping or damage. If any is found then the floss band needs to be replaced. The new heating element will be supplied as shown in Fig 19c. Ensure that the floss band is clean and dry and fit the new element taking care not to damage or stretch it. The leads should be carefully formed around the stainless steel posts as in Fig 19b.

Fig19c (New element)



Fig 19d (Element fitted to floss band)



Heating element is fitted with the flat side of the connector terminal facing downwards

Ensure the leads don't make contact with the posts of the spin head

Fit the floss band and element to the base of the spin head. Fit and tighten the element nuts ensuring that the leads and terminals do not make contact with the metal posts. Fit the top cap, washers and nuts. Centralize the floss band assembly in the spin head before tightening the retaining nuts.

14 AC AND DC DRIVER IDENTIFICATION

AC DRIVERS

- T1 Sugar feed motor
- T2 Stick feed motor
- T3 Vend arm down
- T4 Vend arm up
- T5 Stick agitate solenoid
- T6 Bowl rotate motor
- T8 Spin motor
- T9 Water pump
- T10 Heater element

DC DRIVERS (24V)

- T12 stick rotate motor
- T13 Vend door solenoid
- T15 Flap motor
- T16 Stick grip solenoid

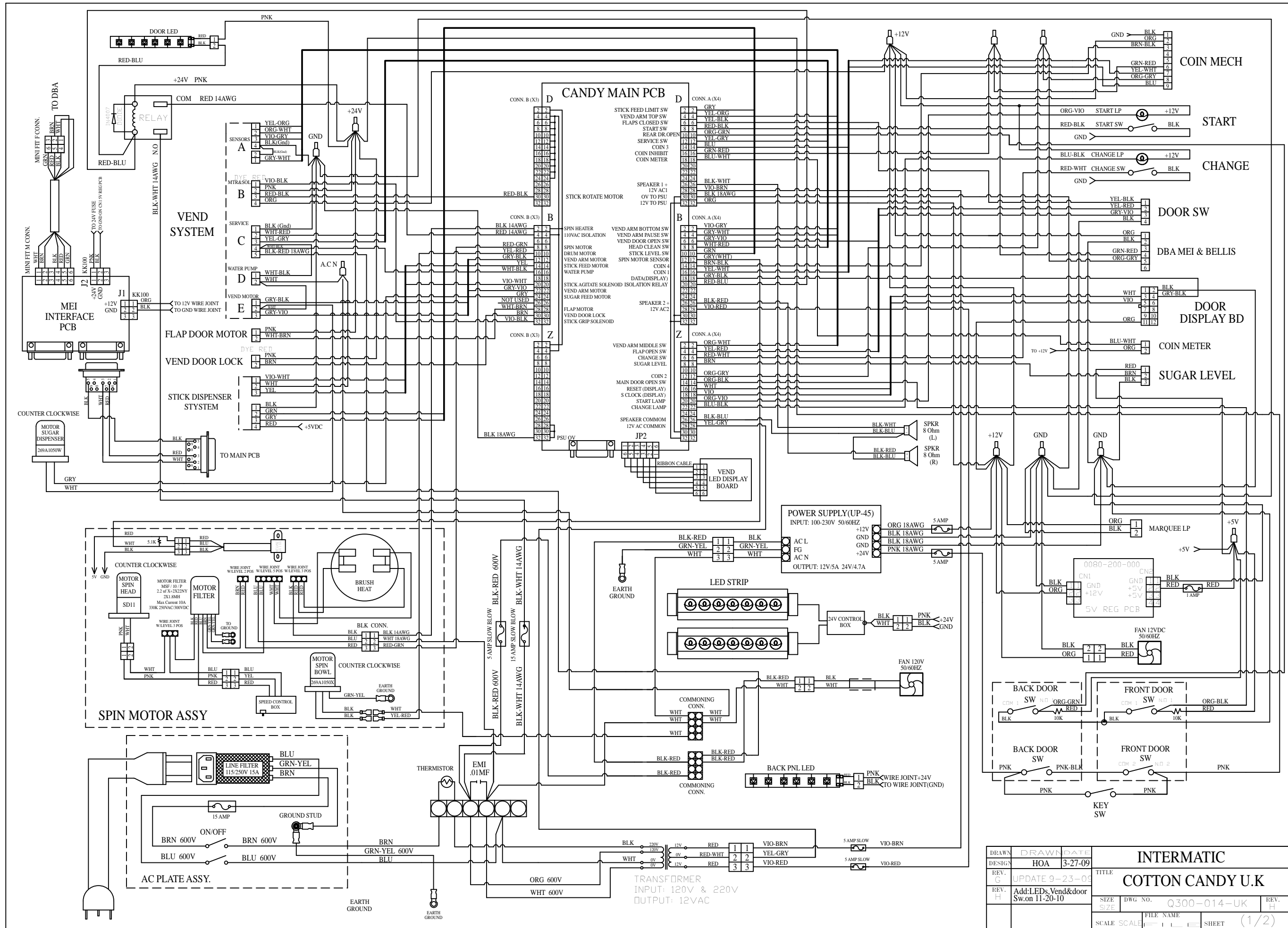

DRAWN	HOA	DATE	3-27-09	INTERMATIC COTTON CANDY U.K.	
DESIGN	G	UPDATE	9-23-09		
REV.	H	Add:LEDs,Vend&door Sw.on 11-20-10		SIZE	DWG NO.
				SCALE	Q300-014-UK
				FILE NAME	REV. H
				SCALE	SHEET (1/2)

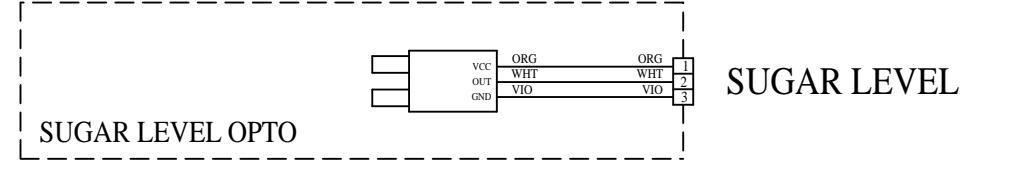
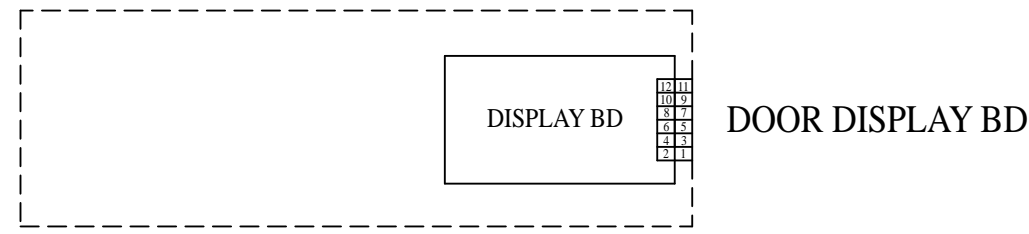
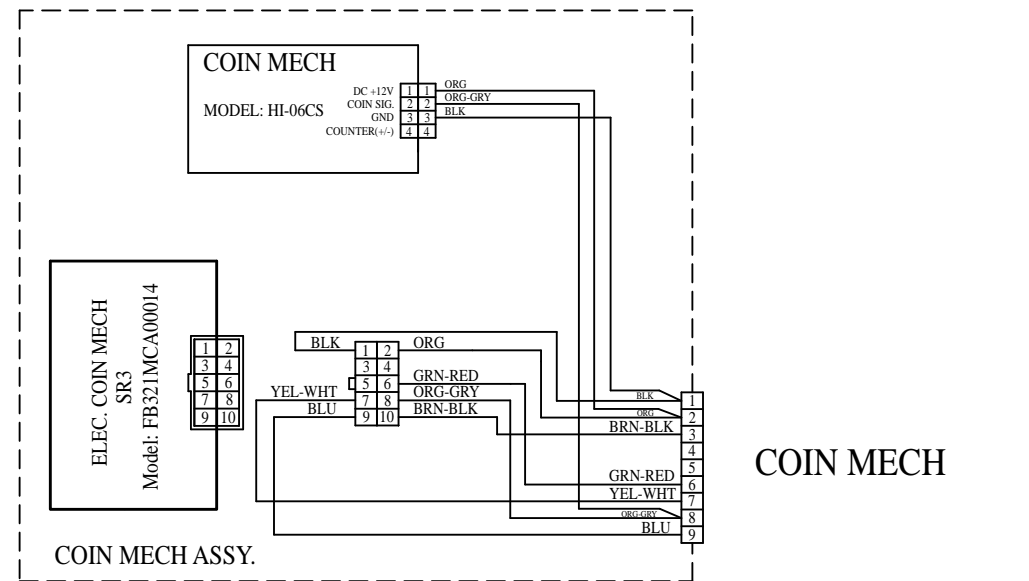
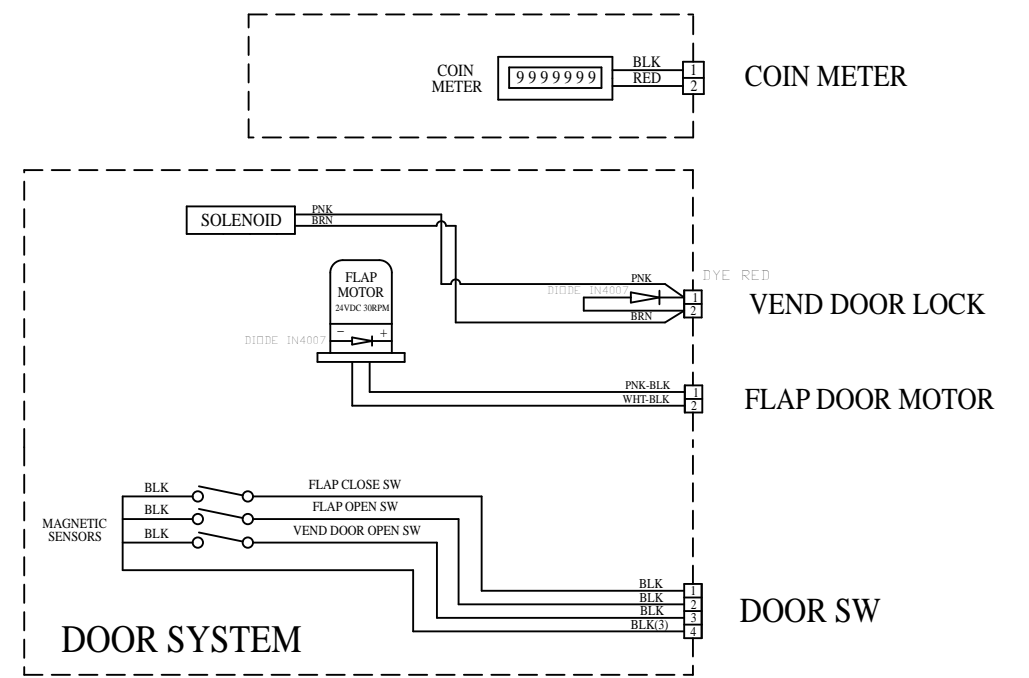
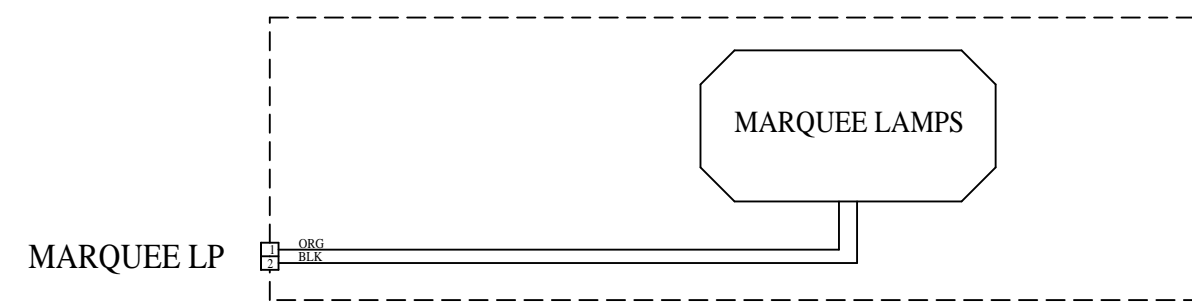
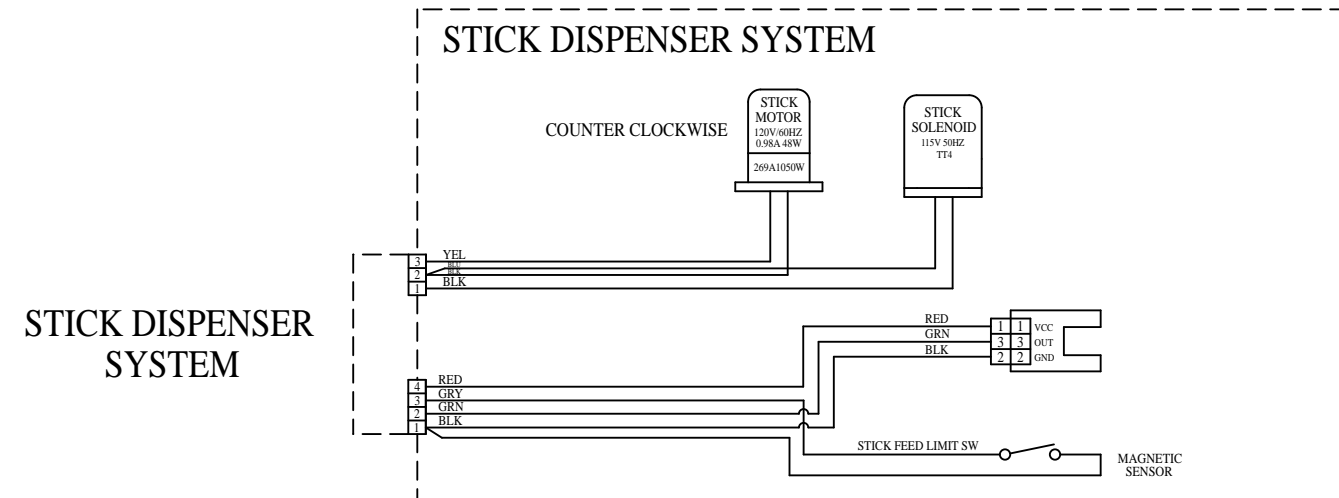
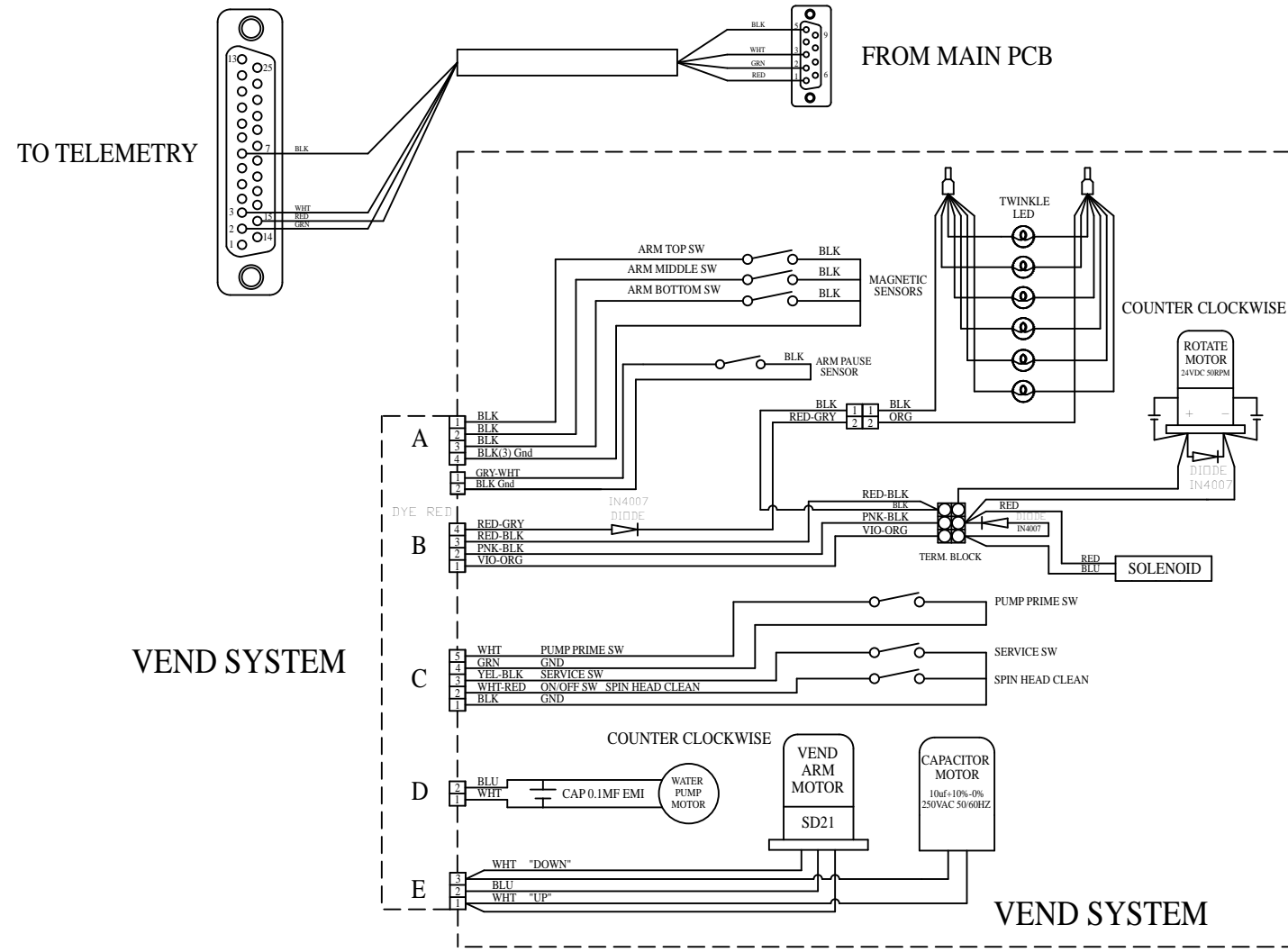

DRAWN	HOA	DATE	2-26-09	INTERMATIC	
DESIGN	ADD:4th SW.on Vend assy.11-22-10	TITLE	COTTON CANDY U.K		
REV.	H	SIZE	DWG NO.	Q300-014-UK	REV. H
		SCALE	SCALE	FILE NAME	SHEET (2/2)