



OPERATION & SERVICE MANUAL

VC1100 Series

MDB-120 Controller

67196-2 Software

120 Volts, 60 HZ

230 Volts, 50 HZ

Seaga Manufacturing, Inc. 700 Seaga Drive, Freeport IL 61032 USA

Phone: 815-297-9500 Fax: 815-297-1700

www.vendtronics.com www.seagamfg.com

A Member of the  Family of Companies.

Table of Contents

SECTION 1 – SPECIFICATIONS

Physical characteristics	4
Environment	4
Health safety protection	4
Electrical and Refrigeration Characteristics	4

SECTION 2 - INSTALLATION

Location	5
Power supply connection	5

SECTION 3 – INITIAL SETUP

Vending	6
Health and Safety Range	6
Temperature Settings	6
Defrost Delay	6

SECTION 4 – OPERATION

Refrigeration System	7
Condensing unit	7
Evaporator	7
Temperature Display	7
Refrigeration Control system	8
Defrost System	8
System Control	8
Door Switch monitoring	9
Idle Condition	9
Coin Acceptance	9
First Bill Acceptance	9
Additional Bill Acceptance	10
DEX / UCS Data Retrieval	10
Vending Selection	11-12

SECTION 5 – PROGRAMMING

The Service Mode of Operation	13
Flow Chart	14
Diagnose	15
Error Codes	16-17
Motor	18
Count	18
Config	18
Account	18
Hist Sales	18
Hist Count	18
Res Sales	18
Res Count	18
Rdr Sales	19
Set Range	19

Table of Contents

SECTION 5 – PROGRAMMING

Range Cash	19
Range Vends	19
Clear	19
Coin	20
Payout	20
Tube Fill	20
Uncon Accp	20
Exact Change	21
Test	22
Test Vend	22
Test Relay	23
Menu 2	
Serv / Contr	24
Price	25
Items	25
Options	26
Bill Escrow	26
Force Vend	26
Max Change	26
Value	26
Multi Vend	27
Free Prod	27
Promo Vend	28
Default	29
Model	29-31
Messages	31
Options	32
Menu 3	
POS / AUX	33
POS	33
Language	34
AUX	34
Time / Date	35
Shutdown	36-37
Temperature	37
Degree	37
Sensor 1	37
Sensor 2	37
Set Point	38
Delta	38
Health	39
Defrost	40-41
Discount	42-43
Autoreinstate	44
Can / Bottle	45
Optic	46

Table of Contents

SECTION 6 WIRING DIAGRAMS

Refrigeration Interface Diagram	47
High Voltage Ladder Diagram 115 Vac	48
High Voltage Ladder Diagram 220-240 Vac	49
Low Voltage Schematic	50
Power Panel Wire Locations 115Vac	51
Power Panel Wire Locations 220-240Vac	52
Dual Coil Tray Wiring	53

SECTION 7 PARTS

Dual Tray, 3 Column	54
Standard Tray 3 Column	55
Tray Options	56
Instructions for converting a 6 Column Tray to a 5 Column Tray	57
Condensing Unit	58
Evaporator	58
Trim	59
Service Door	60-61
Freezer Door and Product Door	62-63
VC1100 Cabinet	64-65
Electrical Panel	66-67
Cable Assemblies	67

SECTION 8 MAINTENANCE 68

SECTION 8 TROUBLESHOOTING 69-70

APPENDIX 1 MESSAGES 71-72

APPENDIX 2 DEX / UCS RECORD SUBSET 73

PHYSICAL CHARACTERISTICS

- Height: 72 in. / 183 cm.
- Width: 41 in. / 104 cm.
- Depth: 32 1/8 in. / 82 cm.
- Weight: 650 lb
- Construction: Heavy Gauge Steel
- Finish: Powder Coated Paint
- Number of Trays: 5
- Maximum Selections: 30 / 45
- Maximum Capacity: 240 / 450
- Available coil sizes: 4,5,6,7,8,10,12,16

ENVIRONMENT

- Operating Ambient Temperature: 50°F to 100°F
- Location Environment: Indoors only

HEALTH AND SAFETY PROTECTION (Vending of products is disabled)

- Activation Temperature:
 - Frozen Foods: +0°F or higher if more than 15 minutes
 - Slack Frozen: +15°F or higher if more than 15 minutes
 - Refrigerated: +41°F or higher if more than 15 minutes
 - None None

ELECTRICAL AND REFRIGERATION REQUIREMENTS

Power Requirements	110 / 120 Vac, 60Hz
Amperage Rating	16
Control Transformer	1/2 Amp fuse
Lamp Transformer	2 Amp fuse
Compressor	3/4 hp Hermetic
Refrigerant Charge	1 lb 10 oz R-404A
Evaporator	Forced air, Elec. Defrost

LOCATION

Upon receipt of the unit, inspect for any shipping damage and report directly to the carrier. A damage report will be necessary before contacting the factory. Allow the unit to set at room temperature for at least 24 hrs. before operation. The unit should be stored or transported vertical at all times. When relocating the unit, it should not be tipped at extreme angles. If the unit is relocated, it is strongly recommended that a similar 24 hr. non-operating period be observed. If the unit was in an operating mode prior to relocation, the inside of the refrigerated compartment should be allowed to rise to room temperature and completely dry out before placing back into service.

The back of the unit must be located at least 6 inches from any obstruction to ensure proper airflow in the compressor area. The system requires air to be induced from underneath the base of the unit, through the air filter and condensing coil, and expelled out the back of the vending machine.

POWER SUPPLY CONNECTION

CAUTION: DO NOT USE AN EXTENSION CORD
--

The 110 / 120 Vac unit requires an independent 20-amp earth grounded circuit.

To insure safe operation of the VC1100, the power supply must be a properly grounded and a polarized outlet must be used. Before plugging the VC1100 into the outlet, test the outlet to confirm it will meet the VC1100 power requirements. If the power requirements are not met, contact a Licensed Electrician and have any necessary corrections made. After connecting to the wall outlet, open the Service Panel and turn the main power switch on. The display on the front panel should become active after approximately 20 seconds.

Upon placement of the machine on location, the following programming should be setup to insure proper operation of the VC1100. Please verify the unit has reached the desired temperature settings before loading product.

The temperature may be viewed at any time by pressing the “0” button on the keypad.

VENDING

Vending operations, such as, setting prices, changing the message on the front display, handling bills, coins, credit, making change, and operating vend motors should be tested before loading product into the machine.

(Refer to Section 5 for programming instructions)

HEALTH AND SAFETY RANGE

The function of this system is to provide additional user protection by disabling vending operations, “PLEASE CALL SERVICE” will be displayed if the air temperature inside the refrigerated space rises above the selected setting for a preset period of time.

Proper Health and Safety settings must be set for proper operation.

Frozen Foods:	+0°F or higher if more than 15 minutes
Slack Frozen:	+15°F or higher if more than 15 minutes
Refrigerated:	+41°F or higher if more than 15 minutes
None:	None:

A magnetic switch is located at the top of the glass door that will provide an additional 60 minutes whenever the service door is opened, an additional 15 minutes will also be provided whenever a defrost cycle occurs.

TEMPERATURE SETTINGS

Temperature settings can be programmed for Degrees Fahrenheit or Degrees Celsius. The Set Point can be programmed to maintain a desired temperature. A minimum 6°F / 14°C delta is recommended to prevent short cycling and extend the life of the Compressor.

The temperature may be viewed at any time by pressing the “0” button on the keypad.

DEFROST DELAY

This option is only necessary if the customer would like the machine to defrost at a specific time. This option allows the user to set the starting point for the first defrost cycle. When a power loss to the Control Board has occurred, 12 hours of operation will be resumed from the moment power was restored, before defrosting.

REFRIGERATION SYSTEM

The system is comprised of an Evaporator, Condensing Unit, and Electronic Control System. The refrigeration system will shut down whenever the glass door is opened. The System Control Board regulates all refrigeration functions; the temperatures can be adjusted by entering the service mode and inputting the desired set point and delta temperature settings. In the event of a Control Board failure, the Refrigeration system will run continuously, and will not cycle off until the Control Board is repaired or replaced.

The Evaporator removes heat from the air in a refrigerated space and transfers the heat to the liquid Refrigerant. The liquid Refrigerant evaporates and is pumped out by the Compressor through the larger diameter tubing. The Compressor pumps the low-pressure vapor into the Condensing Coil where it gets rid of the heat and condenses into a high-pressure liquid. The high-pressure liquid travels through the smaller diameter tubing to the T.E.V. (Thermostatic Expansion Valve). The T.E.V. controls the amount of refrigerant supplied to the Evaporator, and the cycle is repeated.

The temperature can be viewed at any time by pressing the “0” symbol on the keypad.

CONDENSING UNIT

The VC1100 uses a 3/4 hp Tecumseh Condensing Unit. It is located on the base of the cabinet and can be accessed from the back of the unit. It consists of a Compressor, Condensing Coil, Fan, Liquid Receiver, Starting Relay, Start Capacitor, Run capacitor, and a Thermal Overload Protection Device. Two service ports are provided for a Qualified Service Technician to diagnose and repair the Refrigeration System.

EVAPORATOR

The VC1100 uses a low Temperature, Forced Air, and Electric Defrost Evaporator. Each consists of an Evaporating Coil, Thermostatic Expansion Valve, Evaporator Fan, ¼ ton TEV, and a Heating Element. They are located inside each of the refrigerated spaces at the top

WARNING:
UNAUTHORIZED ADJUSTMENT OF THE THERMOSTATIC
EXPANSION VALVE WILL VOID THE WARRANTY!

TEMPERATURE DISPLAY

The temperature sensor readings can be displayed by pressing “0” in the sales mode of operation.

REFRIGERATION CONTROL SYSTEM

The following sequence describes a typical Refrigeration Control cycle.

Upon initial power up, both compartments will begin to cool down.

1. The air temperature inside the refrigerated space cools down to the Cut-Out setting.
2. The Control Board receives a signal from the Temperature Sensor.
3. The Control Board energizes a 24Vdc Refrigeration Relay and opens the Normally Closed Contacts.
4. The Compressor shuts off, Evaporator Fans continue to run.
5. The system remains off until the air temperature inside the refrigerated space warms up to the Cut-In setting.
6. The Control Board receives a signal from the Temperature Sensor.
7. The Control Board de-energizes the Refrigeration Relay and closes the Normally Closed Contacts.
8. The Compressor starts up and the cycle is repeated until the unit goes into defrost.

DEFROST SYSTEM

The Control Board controls the timing of the defrost cycle. The Control Board will simultaneously energize a Defrost Relay, and the Refrigeration relays. When the Defrost Relay is energized, the Normally Closed Contacts open and shut off the Compressor and Evaporator fans, the Normally Open Contacts close and turn the Defrost Heaters on. The electric defrost is automatic and will be initiated every 12 hours. The on time will be approximately 21 minutes. During this period the compressor and evaporator fans are turned off. Whenever power to the Control Board is removed, the Refrigeration will run for a full 12 hrs. before a defrost period begins. The Defrost Start Time, duration, and period can be programmed from within the service mode of operation.

SYSTEM CONTROL

The MDB-120 Selection System Control Board controls the message on the front Display, Bill Acceptor, Coin Changer, Accumulation and Display of Escrow, Issuing Change Payments, Keypad Selection, Vending of product, Price Settings, Health Safety, and Refrigeration Control Functions.

The Sales Mode is the normal mode of operation. The controller will always default to the sales mode under the absence of other inputs.

DOOR SWITCH MONITORING

Both of the door switches will be monitored at all times, if an open to close transition is detected then all health safety related errors, timers, and sold out errors will be reset.

If either glass door is opened the refrigeration system will be switched off. If this open state exceeds 30 minutes then a DOOR OPEN ERROR message will be continuously scrolled across the display and the refrigeration system will be reactivated.

To protect the compressor from encountering overpressure situations due to opening and closing the door repetitively, the controller will not re-activate the refrigeration system for a period of 90 seconds from the initial opening of the glass door.

IDLE CONDITION

The controller will monitor all present MDB peripherals for customer input while waiting for a keypad generated interruption. If no action is taken, then the programmable Point of Sales message will be scrolled on the display; provided there are sufficient coins in the coin changer. If an adequate quantity is not detected, the “PLEASE INSERT EXACT MONEY” message will be displayed. When credit has been established, the amount of credit will be displayed, otherwise the controller will continue as above until a vend sequence is initiated or a Coin Return request is made. If a Coin Return request is received and the Force Vend feature is disabled, the deposited credit will be returned in a “like coin” fashion.

COIN ACCEPTANCE

The controller will allow acceptance of all coins as long as the accumulated credit is equal to or less than the maximum price of any selection in the current configuration. When Multivend is active then this maximum value increases to 3 times the highest priced selection in the machine. Coin acceptance will be disabled during all vends, while coins are being paid out, and while in the service mode of operation, and if card reader credit is established.

FIRST BILL ACCEPTANCE

The first bill will be accepted if the quarter tube is above the low indicator or if the dime and nickel tubes are both above the low indicators. When accumulated credit is greater than or equal to the maximum price, additional bill acceptance will be prevented. When multivend is active then this maximum value increases to 3 times the highest priced selection in the machine. If the bill acceptor offers escrow and acceptance is disabled because of the maximum price, the last bill inserted will be kept in the escrow position, otherwise the bill will go straight into the bill stacker. If the bill acceptor does not offer escrow, or bill escrow is disabled, the bill will go straight to the bill stacker. **The bill will be accepted if the coin tubes total cash amount is greater than or equal to the established credit plus the additional bill value.** If credit is established from a card reader, no bills will be accepted.

ADDITIONAL BILL ACCEPTANCE

Additional bills will be accepted if the dime and quarter tubes are both above the low indicators. If the accumulated credit is greater than or equal to the maximum price, additional bill acceptance will be disabled. When multivend is active then this maximum value increases to 3 times the highest priced selection in the machine. If the bill acceptor offers escrow, and acceptance is disabled because of the maximum price, the last bill inserted will be kept in the escrow position. If the bill acceptor does not offer escrow, or bill escrow is disabled, the bill will go straight to the bill stacker and the bill acceptor will be disabled after the second bill has been sent to the stacker.

DEX / UCS Data Retrieval

DEX / UCS data retrieval is only allowed in the sales mode of operation. The retrieval device initializes the data retrieval after it has been properly connected to the DEX port. Refer to page 73 for the available DEX fields.

VENDING SELECTION

The controller responds to keypad selections from two possible sources. One source is the 120 Select controller's own keypad and the other source is a selection received from an MDB USD peripheral by the 120 Select Controller.

Following reception of any keypad selection, the controller will then calculate a checksum of the MIS and pricing information. The resulting checksum will then be compared to the previous checksum calculated when the controller last changed a MIS or price location.

If the two checksums are different, the vend will not be allowed. This same checksum error will cause the controller to return any deposited credit in a "like coin" fashion.

If the two check sums are identical, then the selection's character, number, and price will be displayed while additional checks on the selection are made in the following order.

- 1) Passes Health and Safety rules
- 2) Item is not in Shutdown range of the 'Timed Shut Down Intervals' feature
- 3) Item is in the configuration and it does not contain a bad motor
- 4) Deposited credit is greater than or equal to the price of the selection

If the selection fails any of these checks then the vending attempt will be aborted. The controller will continue to display the selection's character, number, and price for a period of 1 second. This is followed with three beeps from the speaker along with the one-time scroll of a failure dependent message.

- If the item failed the shutdown check then this scrolled message will be "VENDING OPERATION TO RESUME AT hh.mm". The deposited money will be automatically returned to the customer.
- If check #4 failed then this message will be "PLEASE INSERT MORE MONEY".
- For the other failures, "MAKE ALTERNATE SELECTION" will be the message. The credit or the point of sales message (if no credit has been established) will be displayed again following the message.

If the selection has passed all of the previous checks, the controller will determine if the exact amount of change can be paid to the customer.

The vending sequence will be halted if the controller determines that exact change can not be returned. The controller will return the deposited credit in "like coin" fashion. The controller will issue three beep tones along with one scroll of the "PLEASE INSERT EXACT MONEY" message and then return to the idle condition of the sales mode. If a Promotional item (in response to purchase of another item) failed to vend, the vend is considered good. The failed motor is flagged and displayed in service mode.

If all previous checks have passed then a vend of the selection will be attempted.

A successful vend results in a display of the amount of change while it is returned using a "least coins" algorithm. If the correct change is returned, the "THANK YOU" message will be displayed for 0.8 seconds, followed by the idle condition of the sales mode. If for some reason the exact amount of change cannot be returned, as much as possible will be paid out and the remaining amount will be retained as credit toward another vend. An item price of \$0.00 is allowed as a valid vend while in the sales mode of operation.

When a vend fails, the controller will beep three times while the "MAKE ALTERNATE SELECTION" message is scrolled one time. This will be followed by the amount of accumulated credit. When the force vend feature is enabled, faulty vends will result in an override of the force vend feature. Force vend will stay overridden until the customer has attempted to escrow the credit or vended another product.

For those failed vend attempts of motors connected to the 120 Select controller, if the motor is not allowed to complete a full cycle, or if after twelve seconds the motor has not yet returned to a home position, the vend will be considered a failure.

A bad motor is defined as:

- 1) A motor location requiring more than 12 seconds before detecting a home position signal
- 2) An electrically open motor circuit at the time the controller first attempts to vend the motor.

If a configured motor not in the autoreinstate range has been detected as being bad due to the detection of an open circuit, that motor can not be vended until it is cleared by performing a successful free vend from within the service mode of operation.

When the optics mode is enabled and autoreinstate is inactive for the particular selection but the optical sensor detects no product. In this case, the controller will flag the item with a sold out error (VMC 9) in addition to a long vend error (VMC 2). The controller will also prevent further attempts to vend the particular selection until the selection's sold out error status is cleared.

THE SERVICE MODE OF OPERATIONS

To enter the Service Mode press the red button located on the controller board. The controller automatically returns to the sales mode if no input from the keypad is received in approximately 25 seconds, or if the button is pressed a second time within this period. If credit exists upon entering the service mode, it will be restored when the sales mode is re-established.

At the time of initial entry into and final exit from the service mode, the controller will briefly power all currently configured motors to determine if an open circuit condition exists. Any configured motor that exhibits an open circuit during this process will be immediately removed from the vending machine configuration. This means that a motor previously tagged bad in the sales mode due to an open circuit condition, and presently found to have an open circuit condition upon entry to the service mode, will not be flagged as bad in the diagnostics service mode menu.

For the remainder of the programming section the following commands will be used in place of keypad buttons

5 keypad buttons will be used to navigate the service menu

- A = SCROLL UP
- B = ENTER
- C = SCROLL DOWN
- D = SAVE
- E = EXIT / CANCEL

A	1	2
B	3	4
C	5	6
D	7	8
E	9	0
F	G	H
J	K	L

DI AGNOSE

The Diagnostics menu item displays the current status of the controller and peripherals. Pressing “ENTER” after the user has navigated to the menu item labeled DI AGNOSE starts this function. Upon entry the status of the controller and each of the peripherals will be checked. The order of checking is the Vending Machine Controller, the Changer, the bill Validator, and the card reader. The display will show in that order "VMC", "CHANGER", "VALIDATOR", and "READER". If no problems are encountered with the individual device then the name of the device will be followed by "OK". If problems are encountered then the device name will be followed by an error code.

In the case of the Vending Machine Controller, it's possible that a sequence of error codes could follow the "VMC" display if multiple errors are found with that device. The diagnostics for the VMC will include an error code if any motor in the configuration has been flagged as bad. In addition, the error code for the bad motor will indicate why.

A definition of all possible error codes is shown in the table below. This function may be exited at any time by pressing the "CANCEL" button.

ERROR CODE	ERROR DESCRIPTION
VMC 1	Too little motor current (under 20mA). For an example, the display will show "VMC A1 1"
VMC 2	Too much time to complete vend (12 seconds). For an example, the display will show "VMC C2 2"
VMC 4	NOVRAM checksum error. The display would read "VMC 4"
VMC 5	Health & safety error on temperature sensor 1. The display would read "VMC 5".
VMC 6	Health & safety error on temperature sensor 2. The display would read "VMC 6".
VMC 7	The door is still open after 30 minutes "VMC 7".
VMC 8	Eyes on the activated optical sensor are blocked.
VMC 9	Selection was not detected by optical sensor and, as such, is considered sold out.). For an example, the display will show "VMC A1 9"
CHANGER 3	Loss of changer communications or no changer. The display would show "CHANGER 3".
VALIDATOR 7	Loss of bill validator communications or no bill validator. The display would read "VALIDATOR 7"
READER 8	Loss of card reader communications or no card reader. The display would read "READER 8"

ERROR CODES

Enter the service mode by pressing the red button on the controller, a beep will be issued to recognize the transition and “DIAGNOSE” will be displayed until a function key is pressed. Press the letter “B” to enter the diagnostics menu. The diagnostics routine will present various error codes relating to the nature of a fault condition

VMC 1

If any previously configured selection motor has become disconnected, the Control Board will display VMC 1 after entering the Diagnostics Mode. A successful Test Vend of the selection will clear this Error.

VMC 2

If any selection becomes jammed, turns too slow, or the home switch on the motor does not detect the home position, the Control Board will display a VMC 2. A successful Test Vend of the selection will clear this Error.

VMC 4

A NOVDRAM checksum error indicates that "some" configuration information has changed erroneously. Configuration information consists of prices and all option settings including health safety and temperature settings. When the error occurs, the controller does not know what information changed, just that "some" information changed. It could be a single location or all locations. Your customer must go in and manually check all settings to insure the controller will function, as they want it to. This error will be cleared upon exiting the Service Mode of Operation. Power surges are the most likely cause of a VMC 4 message

VMC 5

A VMC 5 Error indicates that **Sensor 1** air temperature in the refrigerated space has risen above the Health and Safety setting selected by the user. All vending functions within a selected range of rows will be disabled and “MAKE ALTERNATE SELECTION” will be displayed. If all rows are designated in the range, “PLEASE CALL SERVICE “will be displayed. This Error will be cleared upon exiting the Service Mode of operation.

- **Frozen Foods:** **+0°F or higher if more than 15 minutes**
- **Slack Frozen:** **+15°F or higher if more than 15 minutes**
- **Cold:** **+41°F or higher if more than 15 minutes**
- **None:** **None**

VMC 6

A VMC 6 Error indicates that **Sensor 2** air temperature has risen above the Health and Safety setting; The VC1100 does not utilize a 2-sensor mode of operation and must be disabled.

VMC 7

A VMC 7 error indicates that the reset switch at the top of the glass door has remained open for more than 30 minutes. This error will be cleared upon exiting the service mode of operations.

VMC 8

A VMC 8 error indicates that the optical sensor is blocked, the lens is dirty, faulty sensor, or the connector on header P8 is disconnected. This error cannot be cleared until the problem is resolved.

VMC 9

A VMC 9 error indicates that the optical sensor did not detect product. These errors will be automatically cleared by either opening and closing the glass door or exiting the service mode.

CHANGER 3

If the Coin Changer becomes disconnected from the Control Board, (i.e. Broken wire, Faulty Control Board, or Faulty Coin Changer) CHANGER 3 will be displayed. This Error cannot be cleared until the source of the problem is repaired. If the VC1100 uses a Debit Card Reader without a Coin Changer or Bill Acceptor, CHANGER 3 will always be present and cannot be cleared, this is normal

VALIDATOR 7

If the Bill Validator becomes disconnected from the Control Board, (i.e. Broken wire, Faulty Control Board, or Faulty Bill Validator) VALIDATOR 7 will be displayed. This Error cannot be cleared until the source of the problem is repaired. If the VC1100 uses a Debit Card Reader without a Coin Changer or Bill Acceptor, VALIDATOR 7 will always be present and cannot be cleared, this is normal

READER 8

If the Card Reader becomes disconnected from the Control Board, (i.e. Broken wire, Faulty Control Board, or Card Reader) READER 8 will be displayed. This Error cannot be cleared until the source of the problem is repaired. If the VC1100 does not use a Debit Card Reader, READER 8 will always be present and cannot be cleared, this is normal

MOTOR

This menu provides motor count and configuration options. Pressing the "ENTER" button after the user has navigated to the menu item labeled MOTOR will enter this menu. To exit this menu, the "CANCEL" button should be pressed.

➤ COUNT

This function counts and displays the total number of functioning motors. Pressing "ENTER" after the user has navigated to the menu item labeled COUNT starts it. The controller will test each motor drive in the current configuration to determine if a valid motor is connected at that instant. The message COUNT and the number of motors responding will then be displayed. To exit this function, press the "CANCEL" button.

➤ CONF I G

This function is used to remove undesired motor selections from the configuration. Pressing "ENTER" after the user has navigated to the menu item labeled CONF I G starts it. The controller will reconfigure to the currently functioning motors and display CONF I GURED. This is the only means of removing motors from the configuration. To exit this function, press the "CANCEL" button.

ACCOUNT

This menu provides functions for displaying the stored accountability. Pressing the "ENTER" button after the user has navigated to the menu item labeled ACCOUNT will enter this menu. To exit this menu or any of the functions within this menu, the "CANCEL" button should be pressed. Pressing the "ENTER" button may enter all the following accounting functions.

➤ HI ST SALES

Display value of all paid sales since initialization (VA101), which will rollover after \$99,999.95.

➤ HI ST COUNT

Display total number of products vended since initialization (sum of PA201 fields), which will roll over after 79,999,920

➤ RES SALES

Display value of all paid sales since the last reset (VA103), which will rollover after \$9,999.95.

➤ RES COUNT

Displays total number of products vended since the last reset (sum of PA203 fields), which will roll over after 79,999,920.

➤ RDR SALES

Display value of total card reader sales since initialization (no corresponding DEX field), which will rollover after \$9,999.95

➤ SET RANGE

This allows the user to set a range of rows that will be tracked for accounting purposes. Once in this menu item, the user will see a display similar to SR/ER A-L. The user sets the first row in the range by selecting any letter (from "A" through "L"). The last row in the range may then be selected by entering any letter that is greater than or equal to the first row in the range ("A" through "L"). Once the 2 letters in the range are entered, the setting may be saved by pressing the "SAVE" button or canceled by pressing the "CANCEL" button. Pressing either of these buttons forces exit from this submenu and returns control to the previous menu level.

➤ RANGE CASH

Display value of all paid sales over the range defined in SET RANGE submenu since the last reset (sum of PA204 fields in the defined range).

➤ RANGEVENDS

Display total number of products vended over the range defined in SET RANGE submenu since the last reset (sum of PA203 fields in the defined range).

➤ CLEAR

This function allows the user to set all re-settable fields to 0. Upon entry into the function, those re-settable items are cleared and the display shows CLEARED.

COIN

This function is provided for manually filling and dispensing coins from the changer. In addition, there are several functions for controlling credit acceptance and the display of messages related to credit status. Pressing the "ENTER" button after the user has navigated to the menu item labeled COIN enters this menu. To exit this menu or any of the functions within this menu, the "CANCEL" button should be pressed. Pressing the "ENTER" button will enter all the following coin functions.

➤ PAYOUT

This function allows for the dispensing of coins from the inventory tubes. Upon entry into this function the controller will display DISPLAY and wait for the user to press one of the following numbers. The corresponding coins will continue to be paid out until the number is released.

- 1 = Most significant coin
- 2 = Next significant coin
- 3 = Next significant coin
- 4 = Least significant coin

➤ TUBE FILL

Upon entry into this function, the controller will first display FILL COINS. After a short delay, the controller will change the display to show zero credit. At this point, the operator may begin entering coins into the changer. As coins are entered the display will note the total value of the coins entered. After returning to sales mode the credit will be zero. This feature will be inhibited in the service mode if a credit exists from the sales mode before entering service mode.

➤ UNCON ACCP

The Unconditional Acceptance option forces the controller to accept any bill or coin less than a specified value regardless of whether the changer can return an equivalent value of credit. All coins or bills equal to or less than this specified value will be accepted.

Upon entry to this function a five-digit number representing the current unconditional acceptance value appears. A value up to 5 digits may now be entered using the numeric keys. This value may be saved at any time by pressing the SAVE key. **The maximum settable value for Unconditional Acceptance is equal to the largest denomination of currency or coin accepted by the changer or validator.** If the operator attempts to save a value that exceeds this amount, a warning message will appear and the displayed setting will revert to this maximum value. To exit this mode, before entering a value, press CANCEL or exit the service mode.

EXACT CHNG

The Exact Change option forces the controller to display the message PLEASE INSERT EXACT MONEY if a specified value of credit and every value, in increments of the least coin tube value, less than this value cannot be paid back.

Upon entry to this function a five-digit number representing the exact change value appears. A value of up to 5 digits may now be entered using the numeric keys. This value may be saved at any time by pressing the SAVE key.

- When the highest vend price is greater than the unconditional acceptance value, then the maximum settable value for exact change will be 3 times the highest vend price.
- When the highest vend price is less than the unconditional acceptance value then the maximum settable value for exact change is 3 times the unconditional acceptance value.
- If the operator attempts to save a value that exceeds this amount, a warning message will appear and the displayed setting will revert to this maximum value.
- The minimum value for exact change is the unconditional accept value. If the operator attempts to save a value less than this amount, a warning message will appear and the displayed setting will revert to this minimum value.

To exit this mode before entering a value, press CANCEL or exit the service mode.

TEST

This menu provides functions that allow the operator to test motors and/or relay output control lines. Pressing the "ENTER" button after the user has navigated to the menu item labeled **TEST** will enter this menu. To exit this menu or any of the functions within this menu, the "CANCEL" button should be pressed.

➤ TEST VEND

This menu provides functions that allow the operator to test vend either individual motors or a range of motors. Pressing the "ENTER" button after the user has navigated to the menu item labeled **TEST VEND** will enter this menu. Upon entry to the function, the display will read **SELECT - - .**

To test vend a single motor the user should enter the desired selection's letter followed by its number. To test vend a range of motors the user should enter the letter of the first row to vend followed by the letter of the last row to vend. After entering the selection(s), if the operator is satisfied then the "SAVE" button should be pressed to initiate a vend attempt on the selected motor(s). If the operator is not satisfied with the selection or if he/she wants to exit the menu then the "CANCEL" button should be pressed and control will pass back to the higher level where **TEST VEND** will be displayed once again.

When the vend process is initiated, the display will show the particular selection followed by the price of the selection as a vend is attempted. When the vend attempt has completed and the selection corresponded to a single selection or the last selection in a range of selections, control will pass back to the selection display, **SELECT - - .**

- If for any reason, a vend attempt on a particular motor fails then the controller will signal this by beeping 3 times.
- If optical sensor is enabled, the controller will wait for 3 seconds to verify product, if no product was detected then the controller will beep three times before attempting the next selection in the sequence.
- During the process of test vending a range of selections, the operator may press and hold the "CANCEL" button to cancel the process and return control to the selection display, **SELECT - - .**
- A successful test vend on a motor clears all errors associated with that selection.

TEST RELAY

WARNING !!!

The operator should be aware that operations of the functions within this menu have direct control over whatever device(s) is/are connected to those lines. With some devices (such as compressors), there is the potential for damaging the device with frequent toggling of this line.

This menu provides functions that allow the operator to test the operation of the refrigeration and defrost relays. Pressing the "ENTER" button after the user has navigated to the menu item labeled **TEST RELAY** will enter this menu. Upon entry to the menu, the display will read **RELAY1**. By scrolling through the menu the operator may choose 2 additional relay functions, **RELAY2**, and **RELAY3**. To enter any of these functions the operator should press the "ENTER" button.

Upon entry to the individual relay functions, the display will change to reading **ON *** or **OFF *** where the * indicates editing mode. This initial ON/OFF status indicates if the corresponding relay control is active or inactive. Pressing "ENTER" again will toggle the on/off state. At any time, pressing the "SAVE" or "CANCEL" buttons will exit the function. Upon exit from the function the state of the corresponding relay control line will revert to a state that is dependent on the controller's normal relay control algorithm.

➤ RELAY 1

RELAY 1 is the Left Refrigeration Relay and is controlled by Sensor 1 located in the refrigerated compartment. When Relay 1 is off, relay 1 will be energized and the Compressor and Evaporator Fans will be off.

➤ RELAY 2

RELAY 2 is the Right Refrigeration Relay and is controlled by Sensor 2. Relay 2 is not used on the VC1100

➤ RELAY 3

RELAY 3 is the defrost relay. When relay 3 is on, relay 3 will be energized and the heaters will be on. The Compressor and Evaporator Fans will be off.

Menu 2

The following sub-menu's can be accessed within MENU 2

SERV/CONTR

This password accessible menu allows the operator to control which menus will appear during navigation of the service mode. The only menus not under this control are MENU 2, MENU3, and this menu.

The user enters this menu by pressing the "ENTER" button after navigating to the menu item labeled **SERV/CONTR**. Upon entry to this menu, the controller will display **PASS - - -** and request that the operator enter a password. The procedure for entry of the 4-character password follows the same method used for programming POS messages.

Please contact your distributor for password HELP.

If password entry is left early or if the password entered is incorrect then the menu is exited and menu navigation control passes back to the higher level.

If the password entered is correct then control passes to the next lower level. At this point, the display will read **DI AGNOSE** which corresponds to the first selection that appears upon entry to the service mode. The operator may now either:

- 1) Scroll through the remaining functions in the menu which correspond to all of the configurable menus in the service mode
- 2) Enter a function by pressing the "ENTER" button
- 3) Exit this whole menu by pressing the "CANCEL" button which returns control to the menu just above the **SERV/CONTR** menu should be pressed.

If any of the menu items are entered then the display will change to reading **ON *** or **OFF *** where the * indicates editing mode. This initial ON/OFF status indicates if the corresponding service menu is currently active or inactive. Pressing "ENTER" again will toggle the on/off state. At any time the state may be stored and this function exited by pressing "SAVE". If the "CANCEL" button is pressed then the function will not modify the status of the specific service mode menu.

PRI CE

This menu provides functions that allow the operator to assign prices to individual selections, over a range of selections, or to a combination of selections. Pressing the "ENTER" button after the user has navigated to the menu item labeled PRI CE will enter this menu. To exit this menu or any of the functions within this menu, the "CANCEL" button should be pressed. Pressing the "ENTER" button when any of the following functions are highlighted will pass control to that function.

Note that the maximum price that can be set in all of the following cases is 199.99 for a scale factor of 1 and 999.95 for a scale factor of 5.

➤ I TEM (S)

Pressing the "ENTER" button after the user has navigated to the menu item labeled I TEM (S) will enter this menu. Upon entry, the display will read SELECT - - .

- **To set the price of a single selection** the user should enter the letter of the selection followed by its number. After entering the selection, the "SAVE" button should be pressed. The selection's location will be displayed along with a 5-digit price. The desired price should then be entered using the numeric keys starting with the most significant digit followed by lesser significant digits. . Pressing "SAVE" will store the value and return to SELECT - - on the display.
- **To set the price for a range of selections** the user should enter the letter of the first row followed by the letter of the last row. After entering the selections, the "SAVE" button should be pressed. A 5-digit price will appear the display. The desired price should then be entered using the numeric keys starting with the most significant digit followed by lesser significant digits. . Pressing "SAVE" will store the value and return to SELECT - - on the display.
- Pressing the "CANCEL" button while SELECT - - is displayed will return to the PRI CE menu.
- Pressing the "CANCEL" button while 000.00 is displayed will return to the SELECT - - menu.

OPTI ONS

This menu provides functions that allow the operator to control a variety of vending options. Pressing the "ENTER" button after the user has navigated to the menu item labeled "OPTIONS" will enter this menu. To exit this menu or any of the functions or submenus within this menu, the "CANCEL" button should be pressed. Pressing the "ENTER" button when any of the following functions are highlighted will pass control to that function.

➤ BI LL SCROW

This option will allow the last bill accepted to be returned, provided the bill acceptor is capable of such a feature.

Upon entering this function the display will show the current on/off state as On * or OFF *. Pressing "ENTER" again will toggle the on/off state. Pressing "SAVE" will store the setting and exit the menu. Pressing "CANCEL" will exit the menu without modifying the setting.

➤ FORCE VEND

This option will force the customer to complete a purchase once they have deposited money of any form. If a vend is attempted on a configured selection and the motor fails during this vend, the credit will be placed in escrow and the customer would be allowed a credit return in a "like coin" fashion, regardless of the force vend status.

Upon entering this function the display will show the current on/off state as, On * or OFF *. Pressing "ENTER" again will toggle the on/off state. Pressing "SAVE" will store the setting and exit the function. Pressing "CANCEL" will exit the function without modifying the setting.

➤ MAX CHANGE

This option will prevent change from being returned to the customer until the credit amount is less than or equal to the programmed maximum change limit.

Upon entering this submenu, the display will show the current On/Off State as "On" or "OFF". At this point, the user may edit the On/off State or scroll to the "VALUE" function using "UP" or "DOWN". Either function may be entered by pressing "ENTER". If the on/off function is entered then the display will appear as either ON * or OFF * where the * indicates editing mode. Pressing "ENTER" again will toggle Maximum change's on/off state. Pressing "SAVE" will store the setting and exit the function. Pressing "CANCEL" will exit the function without modifying the setting.

➤ VALUE

Upon entering the VALUE function, the display will show the currently programmed maximum change limit. This limit may now be modified in the same manner as described in the price setting procedure.

➤ MULTI VEND

This option will allow the customer to purchase more than one product if enough credit has been deposited. When this option is active, any credit remaining after a vend attempt is not automatically returned. At this point, the customer has one of the following options.

- 1) Making another selection if there's enough credit
- 2) Depositing more money
- 3) Coin return of escrowed credit.

If Force Vend is also active then the customer will be forced to attempt the purchase of at least one item. If a vend is attempted on a configured selection and the motor fails during this vend, the credit will be placed in escrow and the customer will be allowed a credit return in a "like coin" fashion, regardless of the force vend status.

Upon entering this function the display will show the current on/off state as On * or OFF *. Pressing "ENTER" again will toggle the on/off state. Pressing "SAVE" will store the setting and exit the function. Pressing "CANCEL" will exit the function without modifying the setting.

➤ FREE PROD

This option allows a free product to be given to the customer at a preprogrammed interval. When enabled, every nTH product will be vended at no cost, all accumulated credit will be returned, and the message "FREE ON US" will be displayed during the vend process. Setting this interval to '1' provides a free vend at every transaction, '0' disables the option, and the maximum valid interval is 255. Note that determination of free product status is made only after credit equal to or greater than the normal cost of a product has been deposited and the customer has selected the specific product.

Upon entry into this function, the current interval will be displayed as FREE ×××. A new interval may be entered by pressing the numeric keys, these will be displayed as they are entered. The most significant digit followed by lesser significant digits. It is not necessary to enter leading zeros and only the first three numbers will be used. Pressing "SAVE" will store the setting and exit the function. Pressing "CANCEL" will exit the function without modifying the setting.

PROMO VEND

This function will allow a promotional product to be given to a customer for free in response to their purchase of another product. When enabled, purchasing selection '1' from one of the two possible promotional rows will result in both selection '1' and '2' of that row to vend sequentially.

Upon entering this submenu the display will show the current on/off state as "On " or "OFF". At this point, the user may edit the on/off state or scroll to the "RANGE" function using "UP" and/or "DOWN". Pressing "ENTER" may enter either function.

If the on/off function is entered then the display will appear as either ON * or OFF * where the * indicates editing mode. Pressing "ENTER" again will toggle the on/off state. Pressing "SAVE" will store the setting and exit the editing mode.. Pressing "CANCEL" will exit the editing mode without modifying the setting.

➤ RANGE

Programming promotional rows is done in the "RANGE" function. After entering this function the display will show SR/ER X- Y. Where X and Y represent the promotional rows to be programmed (row A, row B...etc.). Pressing the alphabetic keys may enter new rows. The first entry will effect the center character and the second will effect the right most character. To store the rows, press "SAVE" after both entries are entered. Pressing "CANCEL" before "SAVE" will exit the function without storing the new rows.

DEFAULT

This menu provides functions that allow the operator to restore some or many of the controller's default settings. Pressing the "ENTER" button after the user has navigated to the menu item labeled "DEFAULT" will enter this menu. Pressing the "ENTER" button when any of the following submenus or functions are highlighted will pass control to that respective submenu or function. Upon entry to the MESSAGES and OPTIONS functions, the controller will display "CONFIGURED" indicating that the settings associated with the corresponding function are now in effect. To exit any portion of this menu or any of the functions within this menu, the "CANCEL" button should be pressed. The following 3 sections contain tables showing those settings, which take effect when the corresponding function is selected.

➤ MODEL

This function allows the operator to choose a specific set of default machine settings that correspond to the type of vending machine the 120 Select Controller will be used to control.

Upon entry into this function, the controller will display one of the machine types listed at the top of each of the following tables along with an appended "*". The displayed machine type represents the current machine configuration. The "*" indicates that editing mode is active and that the operator may scroll through the available machine types via the "UP" or "DOWN" buttons. Pressing "SAVE" will reconfigure the default settings of the controller to correspond to those associated with the selected type and shown in the table. In addition, a press of the "SAVE" will force an exit from the menu. To exit the menu without saving the selection, press "CANCEL".

The following tables list the default settings that apply to each of the different machine types and that are applied every time a machine type is saved. Following the machine type tables is one additional table listing those default settings that are common to all of the machine types.

VC COLD

This menu is provided for setting the controller to operate a Vendtronics model **VC1100** as a **Refrigerated Fresh Food vending machine**. The following settings will be automatically changed after pressing the “SAVE” button.

<i>CONTROL FUNCTION</i>	<i>SETTING OF CONTROL FUNCTION</i>
Temperature Sensors 1 mode	Enabled (ON)
Set point temperatures for Sensor 1	36° Fahrenheit
Delta temperatures for Sensor 1	6° Fahrenheit
Health Safety Level for Sensor 1	COLD
Health Safety Range for Sensor1	Start row = "A" and End Row = "E"
Temperature Sensors 2 mode	Disabled (OFF)
Set point temperatures for Sensor 2	36° Fahrenheit
Delta temperatures for Sensor 2	6° Fahrenheit
Health Safety Level for Sensor 2	COLD
Health Safety Range for Sensor2	Start row = "F" and End Row = "K"
Duration of defrost cycle	20 minutes
Refrigeration period	12 hours
Optic Sensor mode	Disabled (OFF)
Point of Sales message (POS)	"ENJOY A SNACK TODAY"
Refrigeration relay type	Normally closed

➤ **VC SLACK**

This menu is provided for setting the controller to operate a Vendtronics model **VC1100** as a **Slacked Frozen Food vending machine**. The following settings will be automatically changed after pressing the “SAVE” button.

<i>CONTROL FUNCTION</i>	<i>SETTING OF CONTROL FUNCTION</i>
Temperature Sensors 1 mode	Enabled (ON)
Set point temperatures for Sensor 1	10° Fahrenheit
Delta temperatures for Sensor 1	6° Fahrenheit
Health Safety Level for Sensor 1	SLACK
Health Safety Range for Sensor1	Start row = "A" and End Row = "E"
Temperature Sensors 2 mode	Disabled (OFF)
Set point temperatures for Sensor 2	10° Fahrenheit
Delta temperatures for Sensor 2	6° Fahrenheit
Health Safety Level for Sensor 2	SLACK
Health Safety Range for Sensor2	Start row = "F" and End Row = "K"
Duration of defrost cycle	20 minutes
Refrigeration period	12 hours
Optic Sensor mode	Disabled (OFF)
Point of Sales message (POS)	"ENJOY A SNACK TODAY"
Refrigeration relay type	Normally closed

➤ **VC FROZEN**

This menu is provided for setting the controller to operate a Vendtronics model **VC1100** as a **Frozen Food vending machine**. The following settings will be automatically changed after pressing the “SAVE” button.

<i>CONTROL FUNCTION</i>	<i>SETTING OF CONTROL FUNCTION</i>
Temperature Sensors 1 mode	Enabled (ON)
Set point temperatures for Sensor 1	-10° Fahrenheit
Delta temperatures for Sensor 1	6° Fahrenheit
Health Safety Level for Sensor 1	FROZEN
Health Safety Range for Sensor1	Start row = "A" and End Row = "E"
Temperature Sensors 2 mode	Disabled (OFF)
Set point temperatures for Sensor 2	-10° Fahrenheit
Delta temperatures for Sensor 2	6° Fahrenheit
Health Safety Level for Sensor 2	FROZEN
Health Safety Range for Sensor2	Start row = "F" and End Row = "K"
Duration of defrost cycle	20 minutes
Refrigeration period	12 hours
Optic Sensor mode	Disabled (OFF)
Point of Sales message (POS)	"ENJOY A SNACK TODAY"
Refrigeration relay type	Normally closed

➤ **Dt lft frz**

This menu should never be selected for use in a VC1100.

➤ **Dt rht frz**

This menu should never be selected for use in a VC1100.

➤ **BV COLD**

This menu should never be selected for use in a VC1100.

➤ **MESSAGES**

This menu is provided to reset to the default Point Of Sales message of the corresponding machine types defined in the previous tables.

➤ OPTI ONS

Service Menu Configuration	All menus restored
Diagnostic errors	Cleared
Accounting re-settable Range	Start row = "A" and End Row = "K"
Exact change Value	0
Unconditional Acceptance Value	0
Bill Escrowing	Enabled
Force Vending	Disabled
Multiple Vending	Disabled
Free Product	Disabled
Maximum change	Disabled
Maximum Change Value	20 * least coin factor
Promotional Vending	Disabled
Promotional Vend Range	Start row = "A" and End Row = "A"
Language	English
Time Hours value	0
Time Minutes value	0
Time Date value	1
Time Month value	1
Time Year value	0
Daylight Savings	North American Rules
Shutdown	Disabled
Shutdown Range	Start row = "A" and End Row = "A"
Shutdown Turn-on Times (1 through 4)	00:00 (hours : minutes)
Shutdown Turn-off Times (1 through 4)	00:00 (hours : minutes)
Shutdown Days (1 through 4)	All days are turned off
Temperature Unit of Measurement	Fahrenheit (F)
Discount	Disabled
Discount start time	00:00 (hours : minutes)
Discount end time	00:00 (hours : minutes)
Discount Days	All days are turned off
Discount Range	Start selection = "A1" End selection = "A1"
Discount Value	0
Auto-reinstatement Mode	Disabled (OFF)
Auto-reinstatement Range	Start row = "A" and End Row = "A"
Optic Sensor mode	This is reset to the default setting of the corresponding machine types defined in the tables of the earlier default settings.
Range of Selections covered by Optic Sensor	Start row = "A" and End Row = "K"
All re-settable fields	Cleared

MENU 3

The following sub-menu's can be accessed within MENU 3

POS/AUX

This submenu allows the operator to customize the point of sales messages.

➤ POS

Upon entry into this function, the controller will display MESSAGE. Using the keypad and the following keypad definitions, entering in the new message will over write the old message. Menu I is the default menu, after each keypad entry, from either menu, the keypad will return to menu I. To use menu II, the "SHIFT" key must be depressed prior to the menu II key. To save the length of the message the "ENTER" button must be pressed from within the Menu II. If the maximum limit of 105 characters is entered, the message length is automatically saved.

3x7 keypad mapping

KEYPAD	MENU I	MENU II
A 1 2	A G M	S Y 4
B 3 4	B H N	T Z 5
C 5 6	C I O	U 0 6
D 7 8	D J P	V 1 7
E 9 0	E K Q	W 2 8
F G H	F L R	X 3 9
J K L	SPACE SHIFT BACK SPACE	* ENTER \$

Also associated with this menu are special function characters that allow a special effect or machine specific information to be included in the scrolling POS message. Entry of a special function character involves entering first a '*' character followed by one or two letters. The special function character sequences recognized by the 120 Select controller and their associated functions are listed in the following:

*B	When character is reached, a space will appear and controller will beep
*D1, *D2	Temperature of respective sensor will be displayed.
*P	When character is reached, scrolling will stop for 1/2 second.
*T	Current time will be displayed in military format "hours.minutes".

LANGUAGE

This function allows the operator to choose a specific language in which sales mode messages will be displayed.

Upon entry into this function, the controller will display one of the following nationalities along with an appended *. The displayed nationality represents the currently activated language. The * indicates that editing mode is active and that the operator may scroll through the available languages via the "UP" or "DOWN" buttons. Pressing "SAVE" will activate the currently selected language and exit the menu. To exit the menu without saving the selection, press "CANCEL".

I T A L I A N
D U T C H
S P A N I S H
D A N I S H
E N G L I S H
F R E N C H
G E R M A N
A U X I L I A R Y

See appendix 2 for message translations.

If A U X I L I A R Y is selected out of the previous list then an alternative list of operator created sales mode messages will be used. The function that is used to create those messages is described in the following section.

➤ AUX

This function allows the operator to create custom messages that can be used in place of the customer lead through messages listed in appendix 2.

Upon entry into this function, the controller will display MESSAGE 1. At this point, pressing "UP" or "DOWN" will scroll through the 7 other messages or at any time a press of "ENTER" will allow editing of the selected message. Editing is done in the same fashion as the Point of Sales message. If a message is saved during editing then MESSAGE n+1 will appear on the display. After starting a new message, the message must be saved before starting another function. Each message length limit is listed in appendix 2.

TI ME/DATE

This option will allow the operator to set the time and date for timed operations. Pressing the "ENTER" button after the user has navigated to the menu item labeled TI ME/DATE will enter this menu. Pressing the "ENTER" button when any of the following functions are highlighted will pass control to that function. To exit this menu or any of the functions within this menu without saving settings, the "CANCEL" button should be pressed.

➤ TI ME

Upon entry to this function, the current time of day will be displayed in a 24 hour format as TI ME hh.mm. A new time may be entered by pressing the numeric keys. They will be displayed as they are entered. The most significant digit followed by lesser significant digits. It is not necessary to enter leading zeros and only the first four numbers will be used. To store the time and exit, press "SAVE".

➤ MONTH

Upon entry to this function, the current month will be displayed in a numeric format as MONTH mm. A new month may be entered by pressing the numeric keys. They will be displayed as they are entered. The most significant digit followed by lesser significant digit. It is not necessary to enter leading zeros and only the first two numbers will be used. To store the month and exit, press "SAVE".

➤ DATE

Upon entry to this function, the current date (1 - 31) will be displayed in a numeric format as DATE dd. A new date may be entered by pressing the numeric keys. They will be displayed as they are entered. The most significant digit followed by lesser significant digit. It is not necessary to enter leading zeros and only the first two numbers will be used. To store the date and exit, press "SAVE".

➤ YEAR

Upon entry to this function, the current year will be displayed in a numeric format as YEAR yy. A New Year may be entered by pressing the numeric keys, these will be displayed as they are entered. The most significant digit followed by lesser significant digit. It is not necessary to enter leading zeros and only the first two numbers will be used. To store the year and exit, press "SAVE".

SHUTDOWN

This option will allow the controller to shut down a range of selections or the entire machine based on four time of day intervals. If the time falls within one of these intervals and the entire machine has been selected for shutdown then the customer lead through message VENDI NG OPERATI ON TO RESUME AT hh.mm is scrolled. If a range of selections has been chosen for shutdown that does not encompass the entire machine then the same message will scroll once for every time the customer makes a selection that falls within the range. Note that for each time of day interval, the customer can select from no days up to every day of the week on which the specified time intervals will be active. For any given day these 4 time intervals may overlap one another. Pressing the "ENTER" button after the user has navigated to the menu item labeled SHUTDOWN accesses this option.

Upon entry to the SHUTDOWN menu, the current on/off state of the shutdown option will be displayed as ON or OFF. A press of "ENTER" will change the display to ON * or OFF * where the * indicates editing mode. Pressing "ENTER" again will toggle the on/off state. At any time the state may be stored and this function exited by pressing "SAVE". Pressing the "ENTER" button when any of the following functions are highlighted will pass control to that function. To exit this menu or any of the functions within this menu without saving settings, the "CANCEL" button should be pressed.

➤ TIME

This function allows the start and stop times for shutdown to be programmed. Upon entry into this function, the display will show 1 STRT hh.mm. A new start time for this interval may be entered by pressing the numeric keys, these will be displayed as they are entered. The most significant digit followed by lesser significant digits. It is not necessary to enter leading zeros and only the first four numbers will be used. To save, press "SAVE". The display will continue to 1 STOP hh.mm. A new stop time for this interval may be entered by pressing the numeric keys, these will be displayed as they are entered. The most significant digit followed by lesser significant digits. It is not necessary to enter leading zeros and only the first four numbers will be used. To save, press "SAVE" The display will continue by increasing the leading "1" in the above examples to show the next shut down time. When all four intervals have been programmed the controller will return to the previous level in the menu structure and "TIME" will be displayed.

➤ DAY

This function allows the operator to designate days for the 4 separate shutdown times. Upon entry, the display will show 1 DAY ON or 1 DAY OFF, DAY designates a 3-letter abbreviation corresponding to the day of the week. Pressing "UP" or "DOWN" will scroll through the intervals 1 to 4. Pressing "ENTER" will redirect scrolling control to the DAY field. Pressing the "UP" or "DOWN" keys will scroll through the days of the week for the specified interval. If "CANCEL" is pressed, control passes back to the 1 to 4 interval field. If "ENTER" is pressed, control passes to the On/off field. Pressing of the "UP" or "DOWN" will toggle the daily status for the specific interval between "ON" and "OFF". Pressing "CANCEL" will return control to the "DAY" field. At any point, pressing "SAVE" will store the current status and return control to the interval field. Note that presses of "CANCEL" will only force exit from this function while control is in the interval field

➤ RANGE

This allows the operator to set the range of rows that will be affected when shut down is active. Upon entry into this menu item, the user will see a display similar to SR/ER A- J. The user sets the first row in the range by selecting any letter (from "A" through "L"). The last row in the range may then be selected by entering any letter that is greater than or equal to the first row in the range ("A" through "L"). Once the 2 letters in the range are entered, the setting may be saved by pressing the "SAVE" button or canceled by pressing the "CANCEL" button. Pressing either of these buttons forces exit from this submenu and returns control to the shutdown menu level.

TEMPERTURE

This menu allows the operator to activate and modify the controller's temperature control capabilities. Pressing the "ENTER" button after the user has navigated to the menu item labeled TEMPERTURE accesses this submenu. Pressing the "ENTER" button when any of the following functions or submenus is highlighted will pass control to that function or submenu. To exit this menu or any of the functions within this menu without saving settings, the "CANCEL" button should be pressed.

➤ DEGREE F

This function allows the operator to specify the units of measurement for displaying the temperature. It's the first item reached upon entry to the temperature submenu. The display will read either "DEGREE F" for Fahrenheit units or "DEGREE C" for Celsius units. Pressing "ENTER" will change the display to DEGREE F * or DEGREE C * where the * indicates an editing mode. The units may now be toggle between C and F by pressing the "ENTER" button. Pressing "SAVE" at any time will store the setting and exit editing mode.

➤ SENSOR1

This submenu will allow the operator to control individual characteristics that are associated with SENSOR 1. Pressing the "ENTER" button after the user has navigated to the menu item labeled "SENSOR1" will access that submenu.

➤ SENSOR2

This menu should never be selected for use in a VC1100.

➤ SET POINT

This function allows the user to set an ideal operating temperature for the specific sensor. This corresponds to the air temperature that the controller will attempt to maintain for this sensor while the sensor is activated.

Upon entry, the display will read "XXY" where "XX" is the actual value, and "Y" will be either C for degrees Celsius or F for degree Fahrenheit. Pressing "UP" or "DOWN" will scroll the value of the temperature in the corresponding direction. The maximum value is 70°F (21°C). The minimum value is -30°F (-34°C). The temperature rolls over when the user scrolls through the maximum or minimum values. At any point, the modified value may be stored and this function exited by pressing "SAVE". Pressing "CANCEL" before pressing the "SAVE" button will exit this menu without storing the value.

➤ DELTA

This function allows the user to specify the temperature region around the set point that the refrigeration control will use to switch on and off. The refrigeration Switch-On point is equivalent to the set point plus the delta value divided by 2. The Switch-Off point is the set point minus the delta value divided by 2. The value for delta is set in the same manner as the set point. The maximum value is 20°F (11°C). The minimum value is 5°F (3°C).

Example 1

Set Point	=	36° F
Delta	=	6°F
Switch on	=	39°F
Switch off	=	33°F

Example 2

Set Point	=	36° F
Delta	=	10°F
Switch on	=	41°F
Switch off	=	31°F

HEALTH

This submenu allows the user to specify the operating region for passing health safety requirements and the range of rows over which the health safety requirements will be applied. If the requirements are violated then those rows will be shut down accordingly. Note that each sensor has independent health safety settings. Upon entry to this submenu, the display will read LEVEL. Pressing "UP" or "DOWN" will scroll to RANGE.

➤ **Level**

Upon entry to this submenu ,the display will change to reading either

NONE *,COLD *, SLACK *, or FROZEN *.

These represent the basic health safety rules and the "*" indicates that the controller is in an editing mode. Pressing "UP and/or DOWN" allows the user to scroll through the settings. A selected setting may be saved and the menu exited by pressing "SAVE". To exit the menu without saving, press "CANCEL".

➤ **range**

Upon entry to this submenu ,the display will change to reading "SR/ER A-J". The user sets the first row in the range by selecting any letter (from "A" through "L"). The last row in the range may then be selected by entering any letter that is greater than or equal to the first row in the range ("A" through "L"). Once the 2 letters in the range are entered, the setting may be saved by pressing the "SAVE" button or canceled by pressing the "CANCEL" button. Pressing either of these buttons forces exit from this submenu and returns control to the previous menu level.

A summary of the 4 settings is shown in the following table.

Health Safety Setting	Basic Rule
NONE	Ignore health safety requirements for this sensor
COLD	Block designated rows if temperature exceeds 41 °F (5 °C) for 15 minutes. * *
SLACK	Block designated rows if temperature exceeds 15 °F (-9 °C) for 15 minutes. *
FROZEN	Block designated rows if temperature exceeds 0 °F (-18 °C) for 15 minutes. *

* The time requirements for "FROZEN" or "SLACK" levels do not apply for a period of 75 minutes immediately following machine filling (door open state), servicing (service mode button pressed or door open detected), or a defrost cycle.

* * The time requirements for the "COLD" setting do not apply for a period of 30 minutes immediately following machine filling, servicing, or a defrost cycle.

DEFROST

This submenu allows the user to:

- 1) Set the time **DURATION** for a defrost cycle
- 2) Set the time **PERIOD** between defrost cycles
- 3) Control the **DELAY** time at which the defrost cycle will start
- 4) Force a **MANUAL** defrost operation to run immediately

Upon entry to this submenu the display will read DURATI ON. Pressing "UP" or "DOWN" will scroll through all the submenu items. Pressing "ENTER" will enter the corresponding function of the selected item.

➤ Durati on

Upon entry to this submenu the display will change to reading XX MI N where "XX" is the amount of time in minutes that the defrost cycle will run. Pressing "UP" or "DOWN" will cause the time to increment or decrement by 1 minute in the corresponding direction. The maximum and minimum value is 60 and 10 minutes respectively. The time rolls over when the user scrolls through the maximum or minimum values. At any point, the modified value may be stored and this function exited by pressing "SAVE". Pressing "CANCEL" will exit the function without storing the value.

➤ peri od

Upon entry to this submenu the display will change to reading h.m HRS. Here, "h.m" represents the total amount of time in hours that a refrigeration cycle for either sensor must run before the defrost cycle will execute. Pressing "UP" or "DOWN" will cause the time to increment or decrement by 1 half hour in the corresponding direction. The maximum and minimum value is 24.0 and .5 hours respectively. The time rolls over when the user scrolls through the maximum or minimum values. At any point, the modified value may be stored and this function exited by pressing "SAVE". Pressing "CANCEL" will exit the function without storing the value.

Delay

WARNING !!!

The user is strongly encouraged to set the current time prior to setting the delay.

Due to the fact that the refrigeration cycle is controlled by the controller's real time battery backed clock, adjustment of the current time after the delay value is set can cause the defrost cycle to occur in a shorter interval of time than the actual value. This is a result of the controller's effort to ensure that the refrigeration period always occurs at designated times during the day. Any adjustment of the real time clock's value will not change these periods.

Upon entry to this submenu the display will change to reading 0.0 HRS. Setting and saving any "value" other than 0 will override the current refrigeration cycle. This new one time refrigeration cycle will go into effect immediately upon pressing the "SAVE" button. After this one cycle has expired, a defrost cycle will occur, and the regular refrigeration period controlled by the current value of the **PERIOD** submenu will resume. Adjustment of this value is accomplished by pressing "UP" or "DOWN" which will cause the time to increase or decrease by 1 half hour in the corresponding direction. The maximum and minimum value is 24.0 and 0 hours respectively. The time rolls over when the user scrolls through the maximum or minimum values. At any point, the modified value may be stored and this function exited by pressing "SAVE". Pressing "CANCEL" or saving a value of 0 will cause the submenu to be exited without any corresponding update of the refrigeration cycle.

➤ manual

Upon entry to this submenu the display will change to reading **ON *** or **OFF *** where the * indicates editing mode. Here ON or OFF represents the state of the Manual Defrost Mode. Manual Defrost Mode allows the operator to instantly enable the defrost cycle. The duration of this defrost operation will be equal to the length of time defined in the Duration menu item. Pressing "ENTER" again will toggle the on/off state. At any time the state may be stored and this function exited by pressing "SAVE". Following expiration of the manual defrost operation, a time period of 75 minutes must pass before an automatic defrost cycle can execute.

DI SCOUNT

This option will allow the controller to discount specific items in the machine at pre-programmed intervals.

Pressing the "ENTER" button after the user has navigated to the menu item labeled DI SCOUNT accesses this option. Pressing the "ENTER" button when any of the following functions are highlighted will pass control to that function. To exit this menu or any of the functions within this menu without saving settings, the "CANCEL" button should be pressed.

➤ ON or OFF

Upon entering into the DISCOUNT menu the current On/off State of discounting will be displayed as ON or OFF. A press of "ENTER" will change the display to ON * or OFF * where the "*" indicates editing mode. Pressing "ENTER" again will toggle the on/off state. At any time the On/off state may be stored and this function exited by pressing "SAVE".

➤ TI ME

This function allows the operator to program the start and stop times for discounting. Upon entry into this submenu, the display will show STRT hh.mm. A new start time for this interval may be entered by pressing the numeric keys, these will be displayed as they are entered. The most significant digit followed by lesser significant digits. It is not necessary to enter leading zeros and only the first four numbers will be used. To save the new start time, press "SAVE". The display will continue to 1 STOP hh.mm. A new stop time for this interval may be entered through the same method used for the start time. When the stop time has been programmed the controller will return to the previous level in the menu structure and TI ME will be displayed.

➤ DAY

This function allows the user to specify those days of the week in which discounting will apply. Upon entry, the display will read sun off or sun on. Pressing "UP" or "DOWN" will scroll through the days of the week. If "ENTER" is pressed, control passes to the On/off field for the corresponding day. At this point, presses of "UP" or "DOWN" will toggle the daily discounting status between "ON" and "OFF". Pressing "CANCEL" will return control to the "DAY" field. At any point, pressing "SAVE" will store the current status and return control to the "DAY" field. Note that presses of "CANCEL" will only force exit from this function while control is in the "DAY" field.

RANGE

This allows the operator to set the range of selections that will be affected when discounting is active. Once in this menu item, the user will see a display similar to SR/ER A1 - J2. The user sets the first selection in the range by entering any letter (from "A" through "L") followed by the number of the selection. The last selection in the range is then set by entering any letter that is greater than or equal to the first row in the range ("A" through "L") followed by the number of the selection.

If the letter of the last selection is equal to the letter of the first selection then the number of the last selection must be equal to or greater than the number of the first selection. The software will not save a corresponding range that violates this rule. Once the 2 letters in the range are entered, the setting may be saved by pressing the "SAVE" button or canceled by pressing the "CANCEL" button. Pressing either of these buttons forces exit from this submenu and returns control to the previous menu level.

➤ VALUE

CAUTION!!!

Setting a value greater than or equal to the maximum priced product in the machine will make all products within the discount range free.

This allows the operator to set the discount value that will be applied to those items that are defined in the RANGE menu.

A five-digit number representing the current discount value appears upon entry to this function. Using the numeric keys a value up to 5 digits may now be entered. At any time this value may be saved with a press of the SAVE key. The maximum settable value for discounting is equal to 199.99 for a scale factor of 1 and 999.95 for a scale factor of 5. If the operator attempts to save a value that exceeds this amount, a warning message will appear and the displayed setting will revert to this maximum value.

AUTOREI NST

This option allows the user to set a range of rows so that every time a product in the range is selected, a vend attempt will be made, even if the previous vend attempt resulted in no power ever being detected on a selection's motor.

Pressing the "ENTER" button after the user has navigated to the menu item labeled AUTOREI NST accesses this option. Pressing the "ENTER" button when any of the following functions are highlighted will pass control to that function. To exit this menu or any of the functions within this menu without saving settings, the "CANCEL" button should be pressed.

➤ On or of f

Upon entry into the AUTOREI NST menu the current on/off state of auto-reinstatement will be displayed as ON or OFF. A press of "ENTER" will change the display to ON * or OFF * where the * indicates editing mode. Pressing "ENTER" again will toggle the on/off state. At any time the on/off state may be stored and this function exited by pressing "SAVE".

➤ RANGE

Upon entry into the RANGE menu, the display will show something similar to SR/ER A- J. The user sets the first row in the range by selecting any letter (from "A" through "L"). The last row in the range may then be selected by entering any letter that is greater than or equal to the first row in the range ("A" through "L"). Once the 2 letters in the range are entered, the setting may be saved by pressing the "SAVE" button or canceled by pressing the "CANCEL" button. Pressing either of these buttons forces exit from this submenu and returns control to the previous menu level.

CAN/BOTTLE

ATTENTION !!!

This menu is disabled within the SERV / CONT menu and must be restored into the Service Mode menu before attempting any settings.

(See page 24)

This submenu provides the operator with options for designating ranges of rows that will contain cans and/or bottles. Selections that are designated as either cans or bottles will have an associated vend operation that differs from the normal vend operation. Specifically, after a valid product is selected, **the vend motor will run continuously until a product delivery sensor has signaled the controller**, or the maximum vend time of 9 seconds has expired.

➤ On or off

The current on/off state of the can/bottle option will be displayed as "ON" or "OFF". A press of "ENTER" will change the display to "ON *" or "OFF *" where the "*" indicates editing mode. Pressing "ENTER" again will toggle the on/off state. At any time the state may be stored and this function exited by pressing "SAVE".

➤ RANGE

This item allows the operator to specify those rows of products that contain cans and/or bottles. Upon entry into this item, the display will show something similar to "SR/ER A-J". The user sets the first row in the range by selecting any letter (from "A" through "L"). The last row in the range may then be selected by entering any letter that is greater than or equal to the first row in the range ("A" through "L"). Once the 2 letters in the range are entered, the setting may be saved by pressing the "SAVE" button or canceled by pressing the "CANCEL" button. Pressing either of these buttons forces exit from this submenu and returns control to the previous menu level.

➤ DEPTH

This item allows the operator to specify each selection in the can/bottle range as either a single depth or a double depth item.

SINGLE: Items specified as single depth will vend for an additional 2.5 seconds following detection of the product delivery signal.

DOUBLE: Items specified as double depth will stop the vend motor immediately following detection of the product delivery signal.

Upon entry into this item, the display will show "SELECT xx" where "xx" represents the first selection in the can/bottle range described above. Pressing "UP or DOWN" scrolls through the additional selections in the range. Pressing "ENTER" activates an edit mode for the displayed selection. Pressing "CANCEL" exits the "DEPTH" function. If "ENTER" was pressed, the display will show either "DOUBLE *" or "SINGLE *" where "*" indicates that the setting may be edited. Pressing "ENTER" will toggle between the two modes. The edited setting may be saved by pressing the "SAVE" button or canceled by pressing the "CANCEL" button. Pressing either of these buttons forces an exit from this submenu and returns control to the scroll menu level described in the previous paragraph.

OPTI C

This submenu provides the operator with options for designating ranges of product rows that will be monitored for product delivery by an optical sensor. Selections that are designated as optical will have an associated vend operation that executed in an identical manner to non-optical selections. However, following completion of the vend sequence, the controller will pause for up to 3 seconds while it waits for detection of a product. The controller will then handle the two possible cases as follows:

- a) For the product detection event, the message PLEASE REMOVE PRODUCT will scroll repeatedly across the screen. This message will continue to display as long as the sensor indicates the product is still blocking the optical beam.
- b) In the event that the product is not detected within 10 seconds, the MAKE ALTERNATE SELECTION will appear once followed by a return to the display of available credit. If the auto-reinstate mode is not active for this particular selection then this product detection failure will also trigger the setting of a sold out state for the selection and cause the display of an error code VMC 9 in the diagnostics menu. If the auto-reinstate mode is active for the particular selection then no sold condition will be applied to the failed selection and the controller will continue vend attempts on the particular selection if it's chosen again in the future. This sold out status will be cleared when an open-to-closed transition of the door switch is detected or following an exit from the service mode.

In addition to a modified vending sequence, a blocked optical beam during the non-vending portion of the normal sales mode will cause the handling of credit acceptance and future vending to vary in the following 2 circumstances:

- a) If the optical sensor's range covers all configured selections within the matrix, any additional credit acceptance and vending will be disabled.
- b) If the optical sensor's range covers only a portion of the configured selections within the matrix, vending will be disabled only for those selections within the optical range. Configured selections outside of the range will still be available for vending attempts.

➤ On or off

Upon entry into the OPTIC menu, the current on/off state of the optical option will be displayed as ON or OFF. A press of "ENTER" will change the display to ON * or OFF * where the * indicates editing mode. Pressing "ENTER" again will toggle the on/off state. At any time the on/off state may be stored and this function exited by pressing "SAVE" or pressing "CANCEL" may restore the previously saved state.

➤ RANGE

This item allows the operator to specify those rows of products, which are sensed for product delivery by the optical sensor. Upon entry into this item, the display will show something similar to SR/ER A- J. The user sets the first row in the range by selecting any letter (from "A" through "L"). The last row in the range may then be selected by entering any letter that is greater than or equal to the first row in the range ("A" through "L"). Once the 2 letters in the range are entered, the setting may be saved by pressing the "SAVE" button or canceled by pressing the "CANCEL" button. Pressing either of these buttons forces exit from this submenu and returns control to the previous menu level

VC1100
REFRIGERATION INTERFACE DIAGRAM

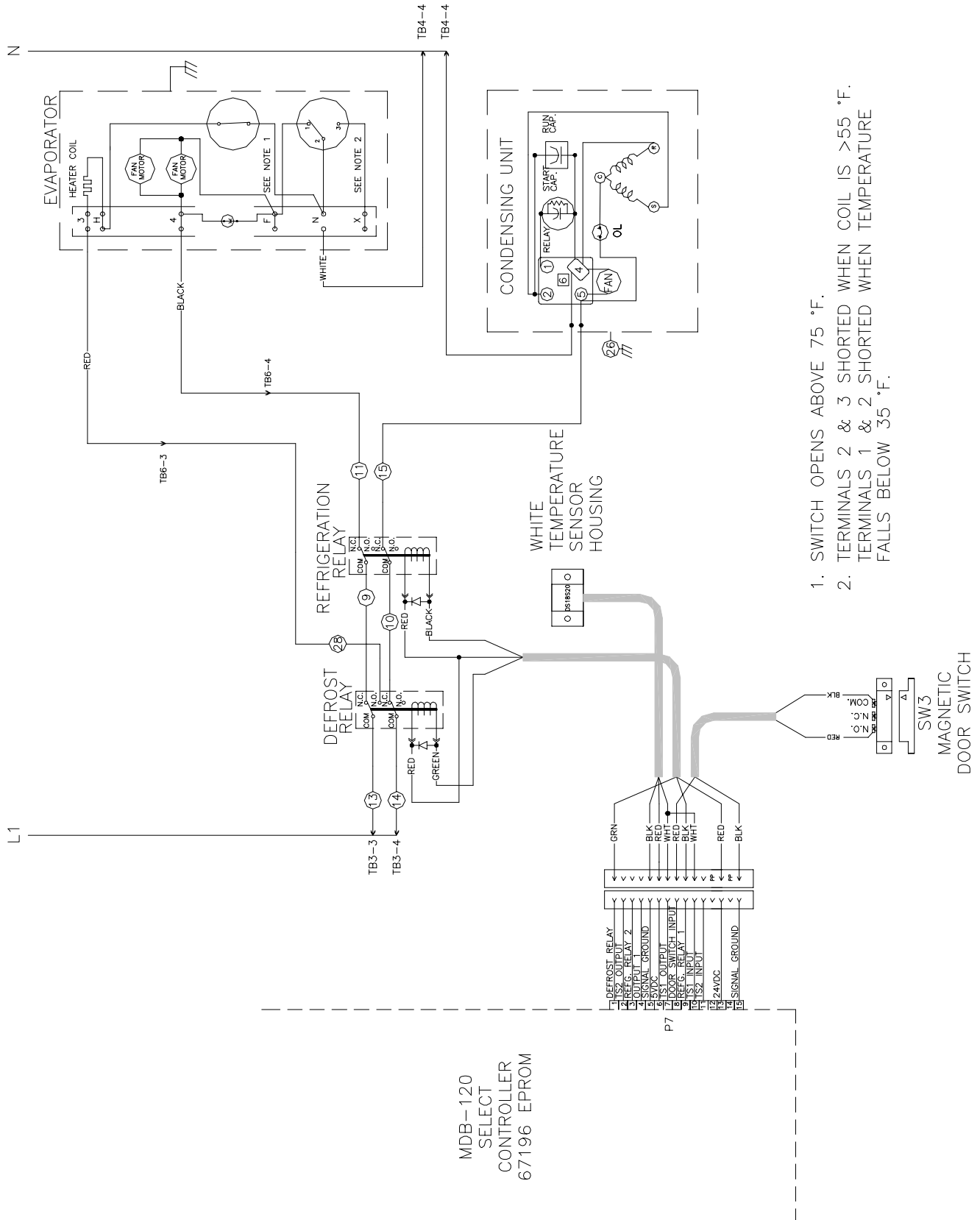

**VC1100 115Vac 60Hz
 HIGH VOLTAGE LADDER DIAGRAM**

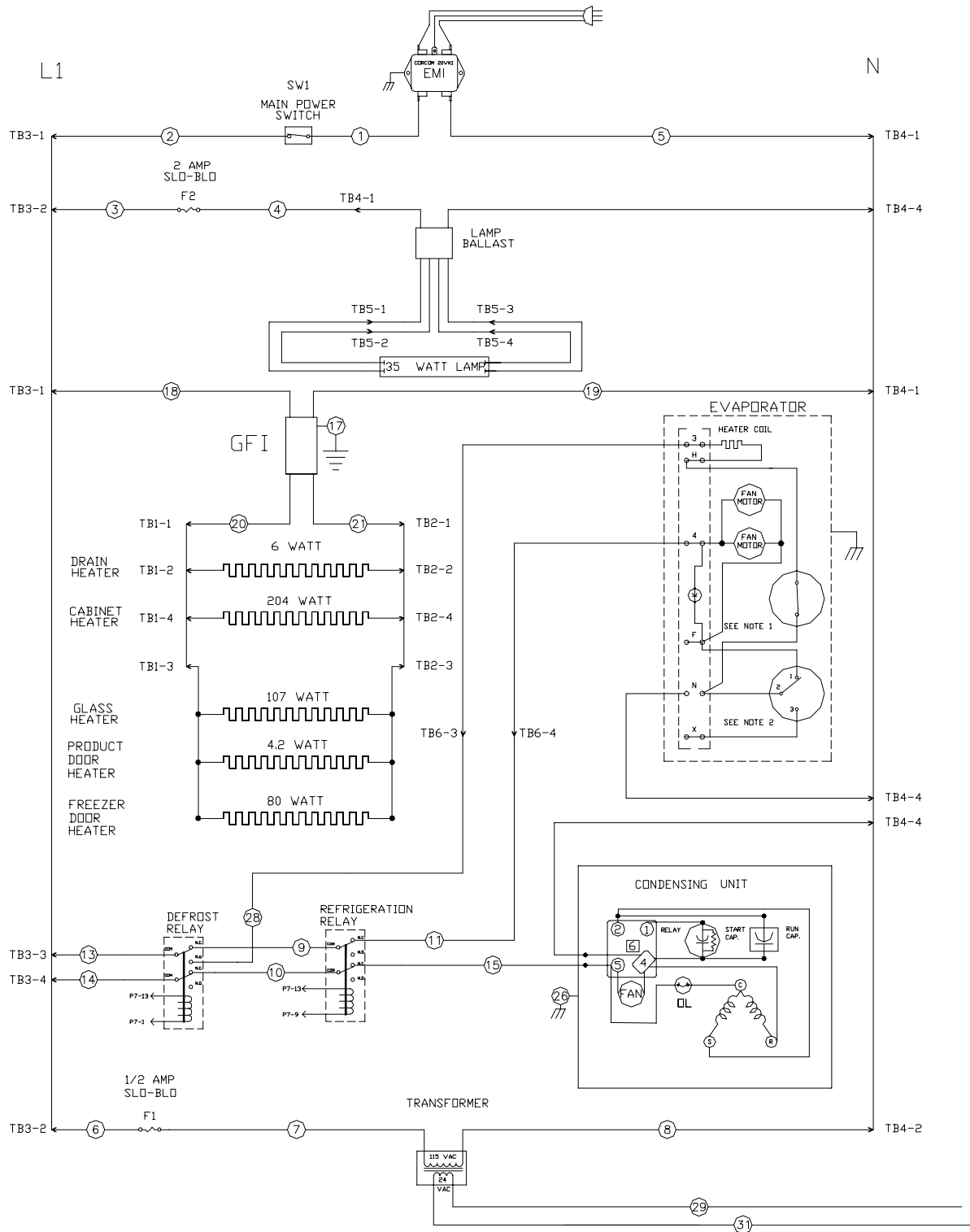

- NOTES:**
1. SWITCH OPENS ABOVE 75 °F.
 2. TERMINALS 2 & 3 SHORTED WHEN COIL IS >55 °F.
 TERMINALS 1 & 2 SHORTED WHEN TEMPERATURE FALLS BELOW 35 °F.

**VC1100 220-240Vac 50Hz
HIGH VOLTAGE LADDER DIAGRAM**

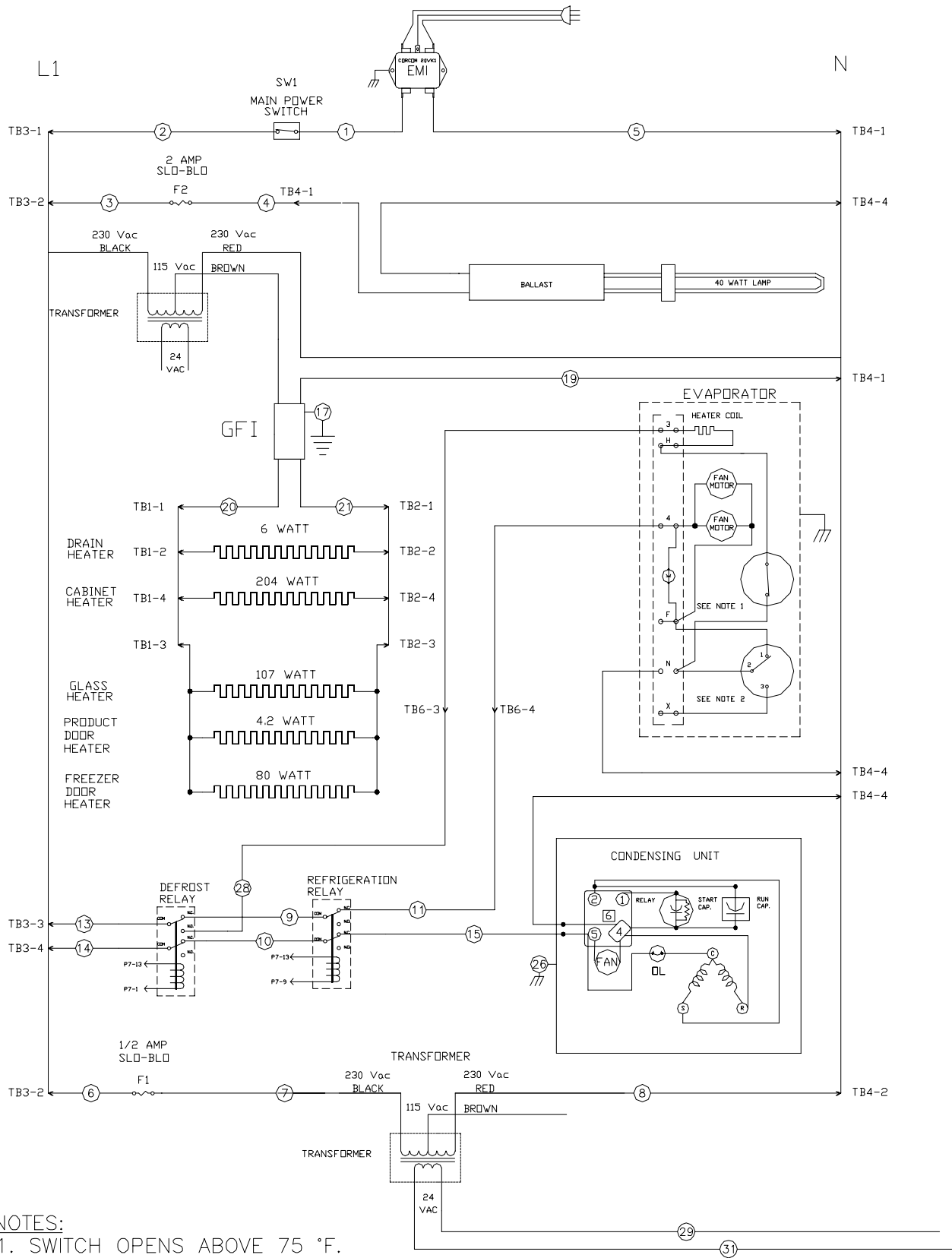

- NOTES:**
1. SWITCH OPENS ABOVE 75 °F.
 2. TERMINALS 2 & 3 SHORTED WHEN COIL IS >55 °F.
 TERMINALS 1 & 2 SHORTED WHEN TEMPERATURE FALLS BELOW 35 °F.

VC1100
LOW VOLTAGE SCHEMATIC

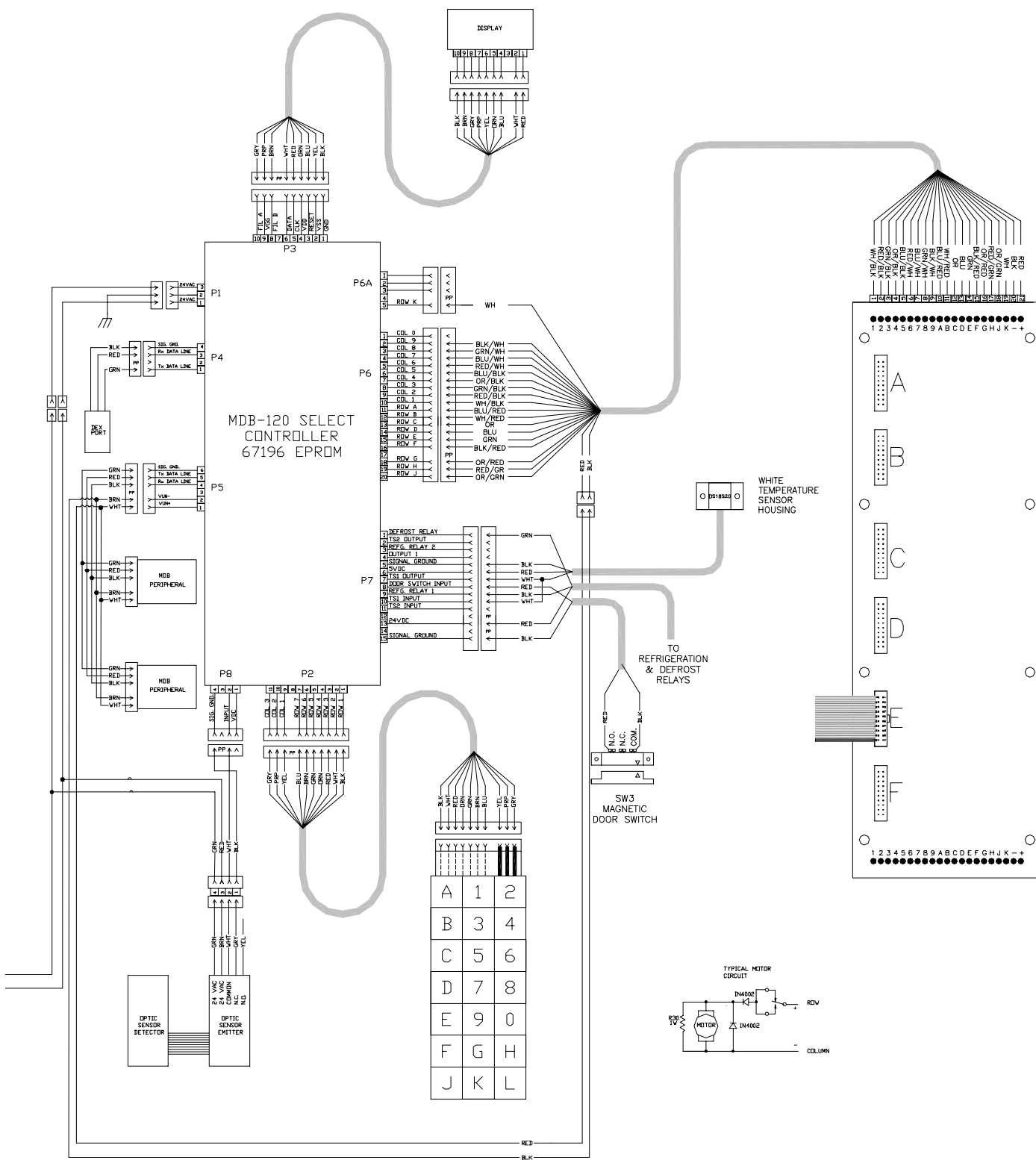

VC1100 115 Vac 60 Hz
POWER PANEL WIRE LOCATIONS

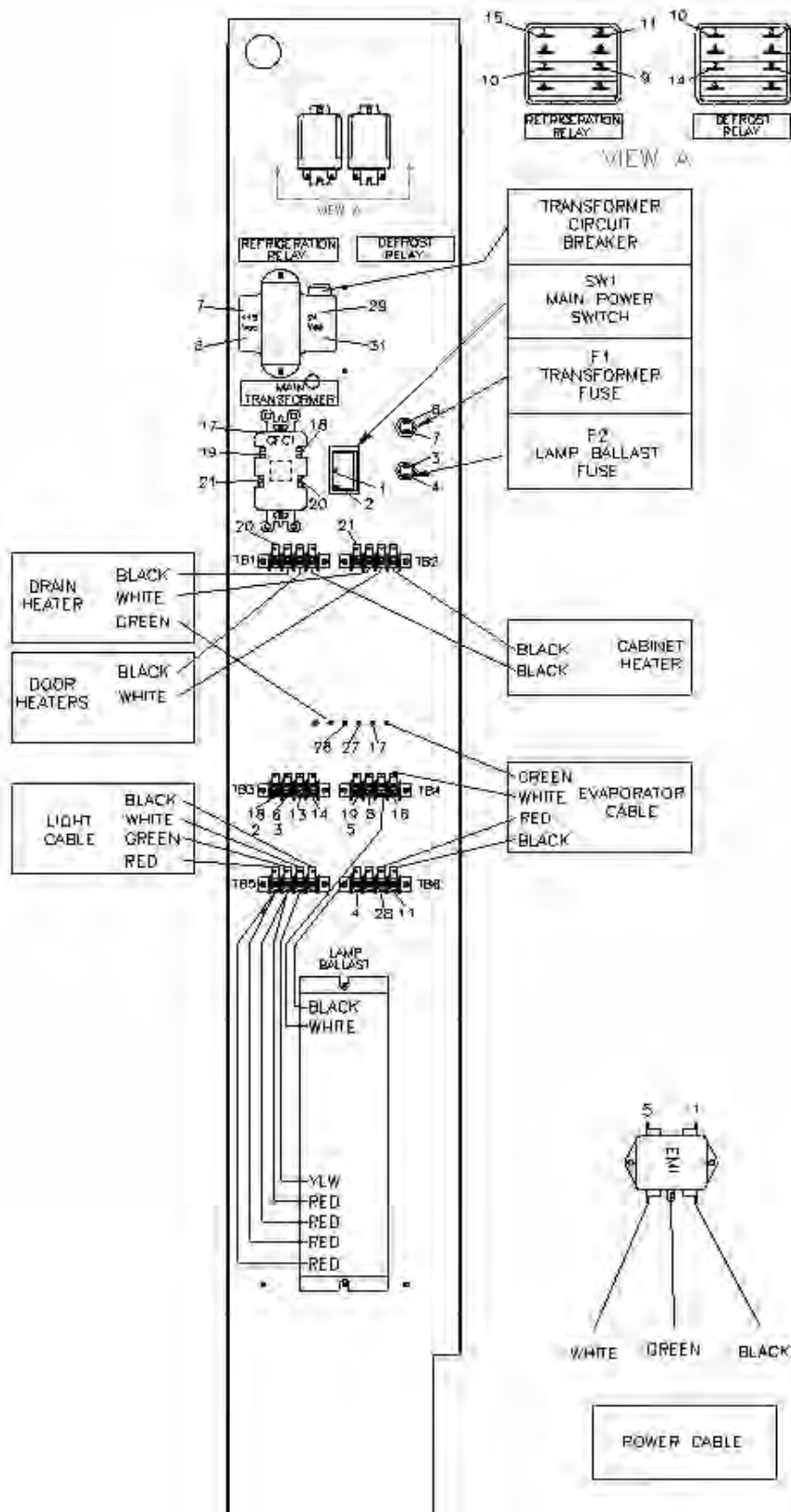

VC1100 220-240 Vac 50Hz
POWER PANEL WIRE LOCATIONS

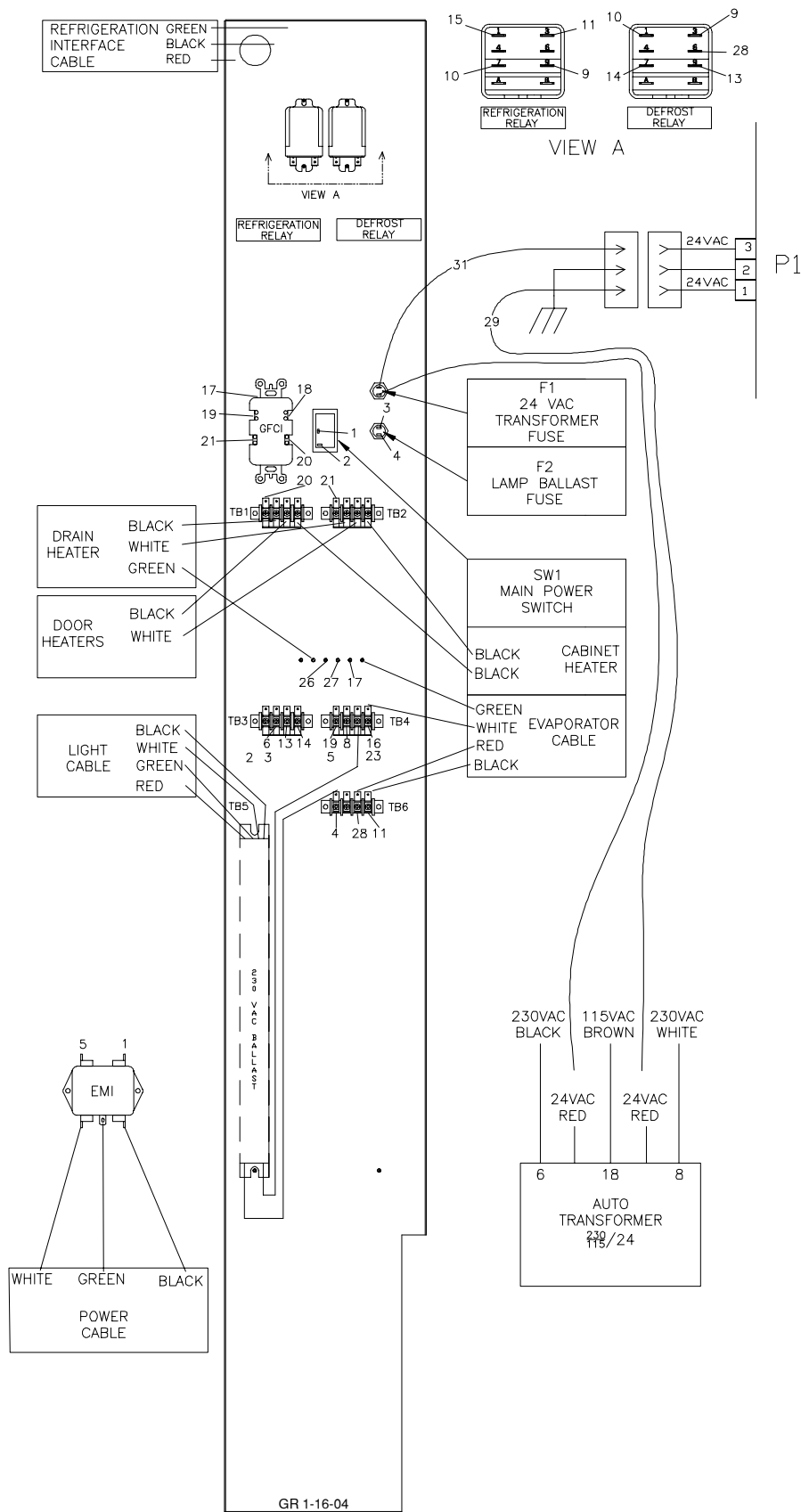

DUAL COIL TRAY WIRING

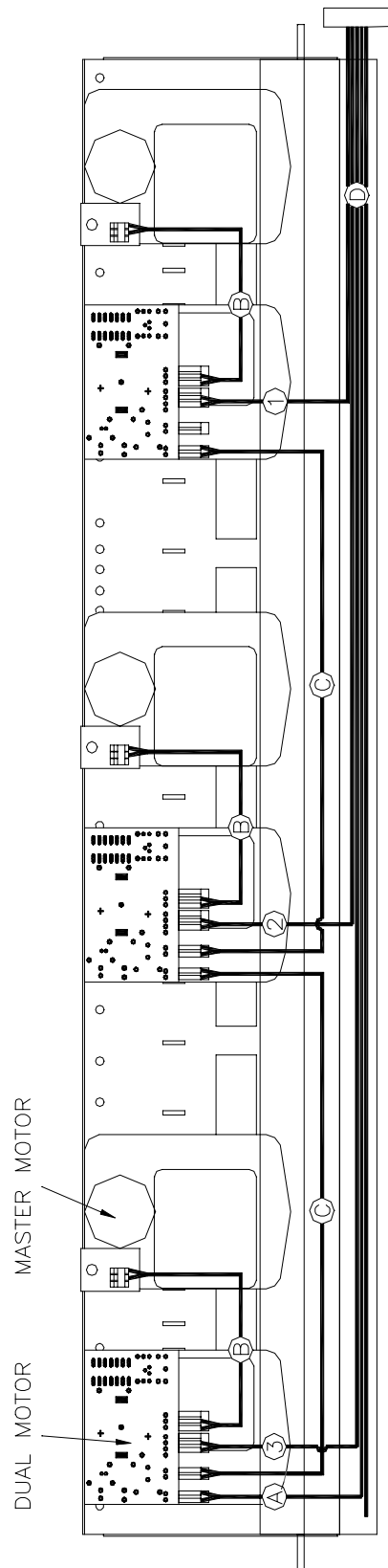

Ⓐ 2 PIN CONNECTOR FROM THE MOTOR HARNESS

Ⓑ 3 PIN JUMPER WIRE

Ⓒ 2 PIN JUMPER WIRE

Ⓓ MOTOR HARNESS

① WIRE MARKER NUMBERS

② WIRE MARKER NUMBERS

③ WIRE MARKER NUMBERS

NOTES:

1. VIEW FACING TRAY BACK.
2. AFTER INSTALLING TRAYS, PRESS THE RED BUTTON ON THE CONTROL SELECT NO.3, THE DISPLAY WILL SHOW "CONFIGURED SELECT NO.2, THE CURRENT NUMBER OF SELECTIONS WILL BE DISPLAY THE CONTROL BOARD WILL ONLY RECOGNIZE THE MASTER MOTORS. SELECT NO.6 OR NO.7 WHEN TESTING MOTORS. NO.8, TEST VEND, DOES NOT FUNCTION ON DUAL MOTOR TRAYS.

**VC1100
 DUAL TRAY, 3 COLUMN**

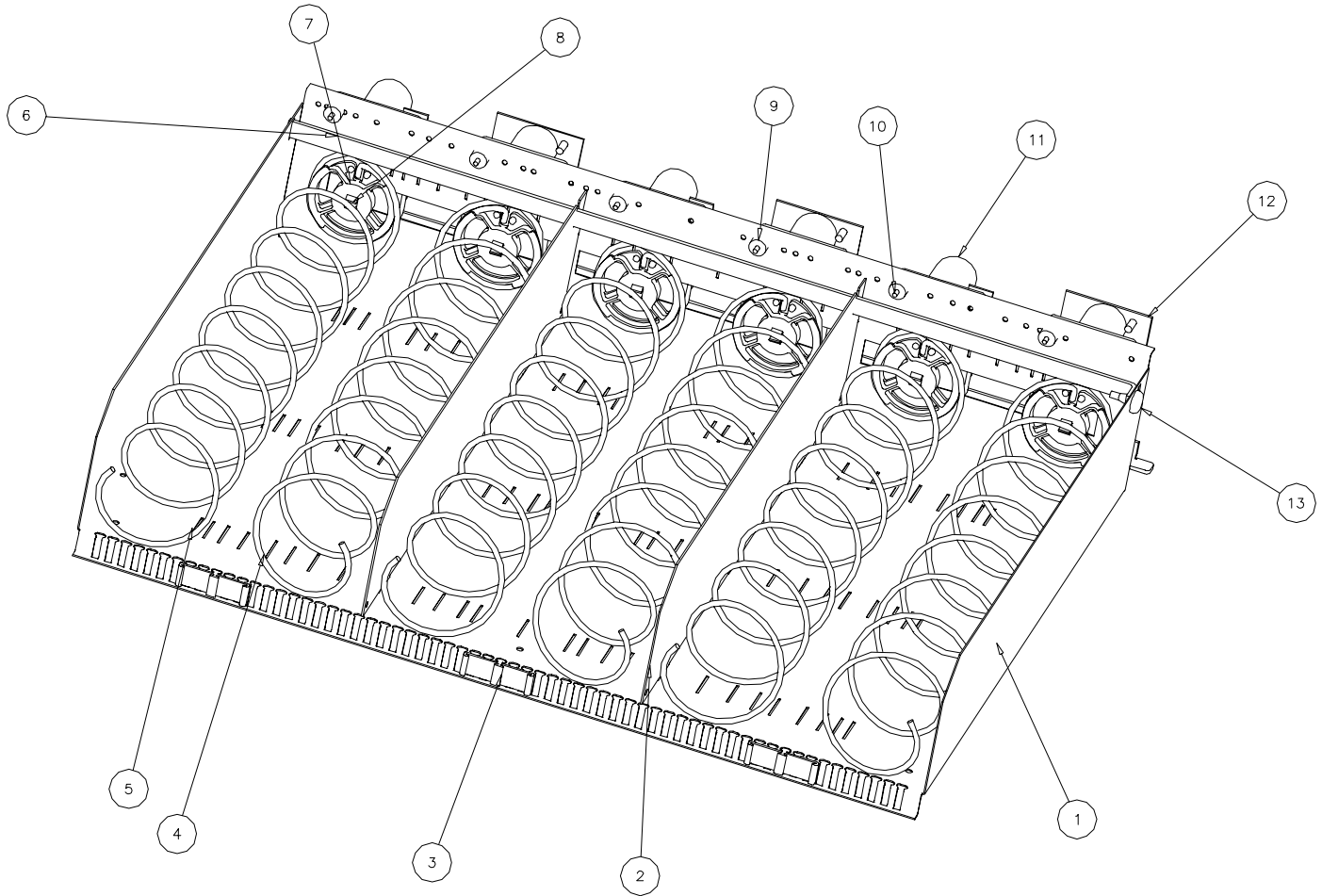

ITEM NO.	DESCRIPTION	PART NO.
1	TRAY	WE112
2	DIVIDER, TRAY	ST750
3	LABEL HOLDER, PRICE & LOCATION	PL740
4	COIL, RH, 07 VEND, 3.00DIA	WF731
5	COIL, LH, 07 VEND, 3.00DIA	WF730
6	TRAY DIVIDER LOCK	ST751
7	RETAINER HUB, VEND MOTOR	PL730
8	SHAFT ADAPTER, VEND MOTOR	PL731
9	MOTORMOUNT, RUBBER STOPPER	FA754
10	PIN, CLEVIS, VEND MOTOR MNT ALUM	FA778
11	MOTOR, VEND, 24DC, SEALED	EL801
12	SA, VEND MTR, DUAL	SA116
13	TRAY DIVIDER LOCK, RUBBER	FA763

**VC1100
 STANDARD TRAY, 3 COLUMN**

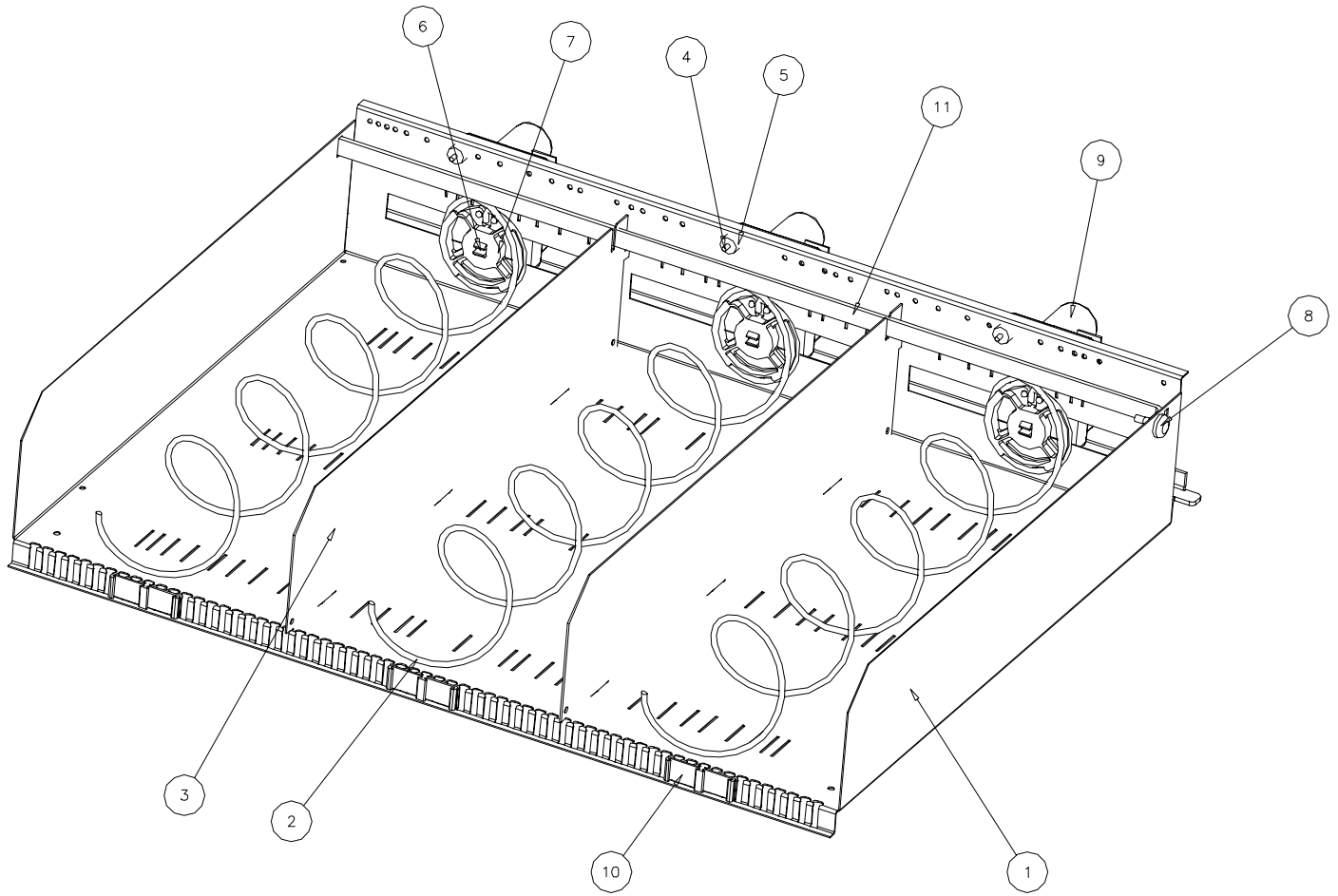

ITEM NO.	DESCRIPTION	PART NO.
1	TRAY	WE112
2	COIL,LEFT HAND,4VEND,3.00DIA	WF724
3	DIVIDER,TRAY,VC1100	ST750
4	PIN,CLEVIS,VEND MOTOR MOUNT, ALUMINUM	FA778
5	MOTORMOUNT,RUBBER STOPPERS	FA754
6	RETAINER HUB,VEND MOTOR	PL730
7	SHAFT ADAPTER,VEND MOTOR	PL731
8	TRAY DIVIDER LOCK,RUBBER	FA763
9	VEND MOTOR	EL801
10	LABEL HOLDER,PRICE & LOCATION	PL740
11	LOCK,DIVIDER	ST751

TRAY OPTIONS

ITEM NO.	DESCRIPTION	PART NO.
1	COIL,LEFT HAND,10VEND,2.50DIA	WF720
2	COIL,LEFT HAND,10VEND,3.00DIA	WF721
3	COIL,LEFT HAND,8VEND,3.00DIA	WF722
4	COIL,LEFT HAND,6VEND,3.00DIA	WF723
5	COIL,LEFT HAND,4VEND,3.00DIA	WF724
6	COIL,RIGHT HAND,8VEND,3.00DIA,DUAL TRAY	WF725
7	COIL,RIGHT HAND,6VEND,3.00DIA,DUAL TRAY	WF726
8	COIL,RIGHT HAND,4VEND,3.00DIA,DUAL TRAY	WF727
9	COIL,LEFT HAND,5VEND,3.00DIA	WF728
10	COIL,LEFT HAND,8VEND,2.50DIA	WF729
11	COIL,LEFT HAND,7VEND,3.00DIA	WF730
12	COIL,RIGHT HAND,7VEND,3.00DIA,DUAL TRAY	WF731
13	COIL,RIGHT HAND,5VEND,3.00DIA,DUAL TRAY	WF732
14	COIL,RIGHT HAND,10VEND,3.00DIA, DUAL TRAY	WF733
15	COIL,LEFT HAND,12VEND,3.00DIA	WF734
16	COIL,RIGHT HAND,12VEND,3.00DIA, DUAL TRAY	WF735
17	COIL,LEFT HAND,16VEND,3.00DIA	WF736
18	CONVERSION KIT,VEND MTR,DUAL,1COL,4COIL	SA117
19	CONVERSION KIT,VEND MTR,DUAL,2COL,4COIL	SA122
20	CONVERSION KIT,VEND MTR,DUAL,3COL,4COIL	SA127
21	CONVERSION KIT,VEND MTR,DUAL,4COL,4COIL	SA132
22	CONVERSION KIT,VEND MTR,DUAL,1COL,6COIL	SA119
23	CONVERSION KIT,VEND MTR,DUAL,2COL,6COIL	SA124
24	CONVERSION KIT,VEND MTR,DUAL,3COL,6COIL	SA129
25	CONVERSION KIT,VEND MTR,DUAL,4COL,6COIL	SA134
26	CONVERSION KIT,VEND MTR,DUAL,1COL,8COIL	SA121
27	CONVERSION KIT,VEND MTR,DUAL,2COL,8COIL	SA126
28	CONVERSION KIT,VEND MTR,DUAL,3COL,8COIL	SA131
29	CONVERSION KIT,VEND MTR,DUAL,4COL,8COIL	SA136
30	CONVERSION KIT,VEND MTR,DUAL,1COL,5COIL	SA118
31	CONVERSION KIT,VEND MTR,DUAL,2COL,5COIL	SA123
32	CONVERSION KIT,VEND MTR,DUAL,3COL,5COIL	SA128
33	CONVERSION KIT,VEND MTR,DUAL,4COL,5COIL	SA133
34	CONVERSION KIT,VEND MTR,DUAL,4COL,7COIL	SA135
35	CONVERSION KIT,VEND MTR,DUAL,3COL,7COIL	SA130
36	SCREW,THUMB KNOB,#6-32x1/2	FA780
37	PRODUCT RISER KIT	SA157
38	LINER,TRAY,7.75INCH,3 COLUMN TRAY	PL724
39	VEND MOTOR WITH COIL RETAINER ASSEMBLY	SA115
40	PRODUCT PUSHER,COIL,LARGE,BLACK	PL743
41	LABEL,TRAY,PROD PRICING	DE727
42	LABEL,TRAY,PRODUCT LOCATION,A1-K9	DE728

Instructions for converting a 6 Column Tray to a 5 Column Tray

TRAY REMOVAL

1. Open service door and open the freezer door
2. Remove the product from the tray.
3. Unplug the tray cable from the green mother-daughter board located behind the trays on the inner back wall.
4. Unlock the tray cable mount located on the left inner side wall, near the back of the trays.
5. Remove the tray from the machine by guiding the tabs on the back of the tray through the openings on the tray rails.

DISASSEMBLY

6. Remove the coils by pulling them directly out of the vend motors.
7. Remove the divider lockbar and the grommet that holds the lockbar in place.
8. Remove the dividers by pulling forward and upward.
9. Remove the motor pins and rubber retainers from the motors.
10. Unplug motor #6 from the harness and remove the motor from the tray.

ASSEMBLY

11. Replace the dividers in the appropriate slots for a 5 column tray.(you will have one extra divider left over)
12. Position the motors in the middle of each column, insert the motor pins and rubber retainers.
13. Insert the divider lockbar into the slots on the dividers and fasten the lockbar to the tray with the rubber retainer.
14. Insert the New coils into the motors (end of the coil should be at 6:00 o'clock position)

TRAY INSTALLATION

15. Slide the tray into the machine by guiding the tab on the back of the tray into the openings on the tray rails.
16. With the tray pulled all the way forward and tilted, snap the tray cable into the tray cable mount.
17. Plug the tray cable into the green motor interface board.

TESTING

18. Press the red mode button on the controller.
19. Press the A button twice, then the B button twice to enter the test vend feature
20. Press the tray letter twice and then press save (D button) to initiate a test vend on all of the motors for that tray.)

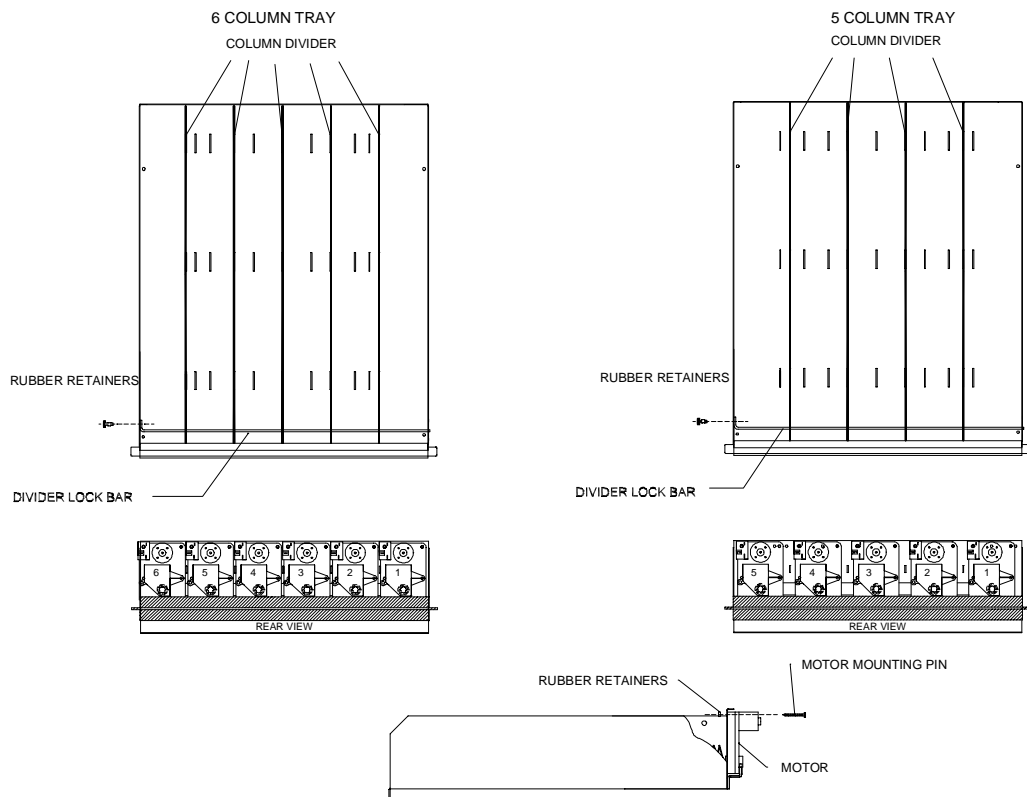

CONDENSING UNIT

ITEM NO.	DESCRIPTION	PART NO.
115VAC / 60HZ		
1	3/4 HP CONDENSING UNIT,115V	RE723
2	3/4 HP COMPRESSOR,115V	RE738
3	FAN MOTOR,115V	RE740
4	FAN BLADE	RE744
220-240VAC / 50HZ		
1	3/4 HP CONDENSING UNIT,220-240	RE746
2	3/4 HP COMPRESSOR,220-240	RE742
3	FAN MOTOR,220-240	RE741
4	FAN BLADE	RE744

EVAPORATOR

ITEM NO.	DESCRIPTION	PART NO.
115VAC / 60HZ		
1	EVAPORATOR,1600BTU,115V	RE724
2	EXPANSION VALVE,1/4TON,ADJUSTABLE	RE726
3	THERMOSTAT, HEAT LIMITER (2 WIRES)	RE745
4	THERMOSTAT, FAN DELAY (3 WIRES)	RE747
5	FAN MOTOR,115V	RE748
220-240VAC / 50HZ		
1	EVAPORATOR,1600BTU,220-240	RE743
2	EXPANSION VALVE,1/4TON,ADJUSTABLE	RE726
3	THERMOSTAT, HEAT LIMITER (2 WIRES)	RE745
4	THERMOSTAT, FAN DELAY (3 WIRES)	RE747

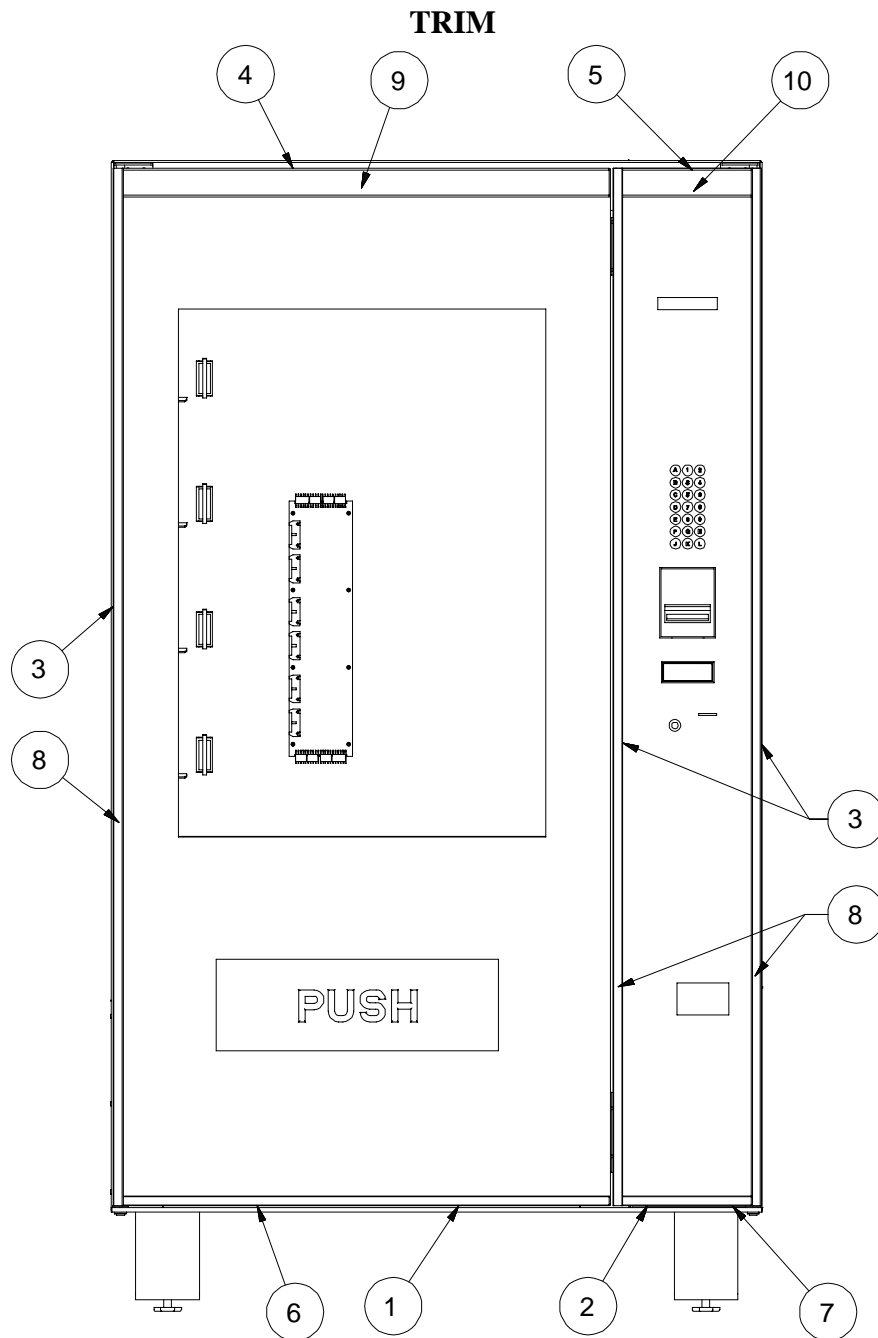

ITEM NO.	DESCRIPTION	PART NO.
1	TRIM, BOTTOM, FREEZER DOOR	HA750
2	TRIM, BOTTOM, SERVICE DOOR	HA751
3	TRIM, SIDES, FRZ & SVC DOOR	HA752
4	TRIM, TOP, FREEZER DOOR	HA753
5	TRIM, TOP, SERVICE DOOR	HA754
6	MOULDING, BOTTOM, FREEZER DOOR	HA760
7	MOULDING, BOTTOM, SERVICE DOOR	HA761
8	MOULDING, SIDES, FRZ & SVC DOOR	HA762
9	MOULDING, TOP, FREEZER DOOR	HA763
10	MOULDING, TOP, SERVICE DOOR	HA764

SERVICE DOOR

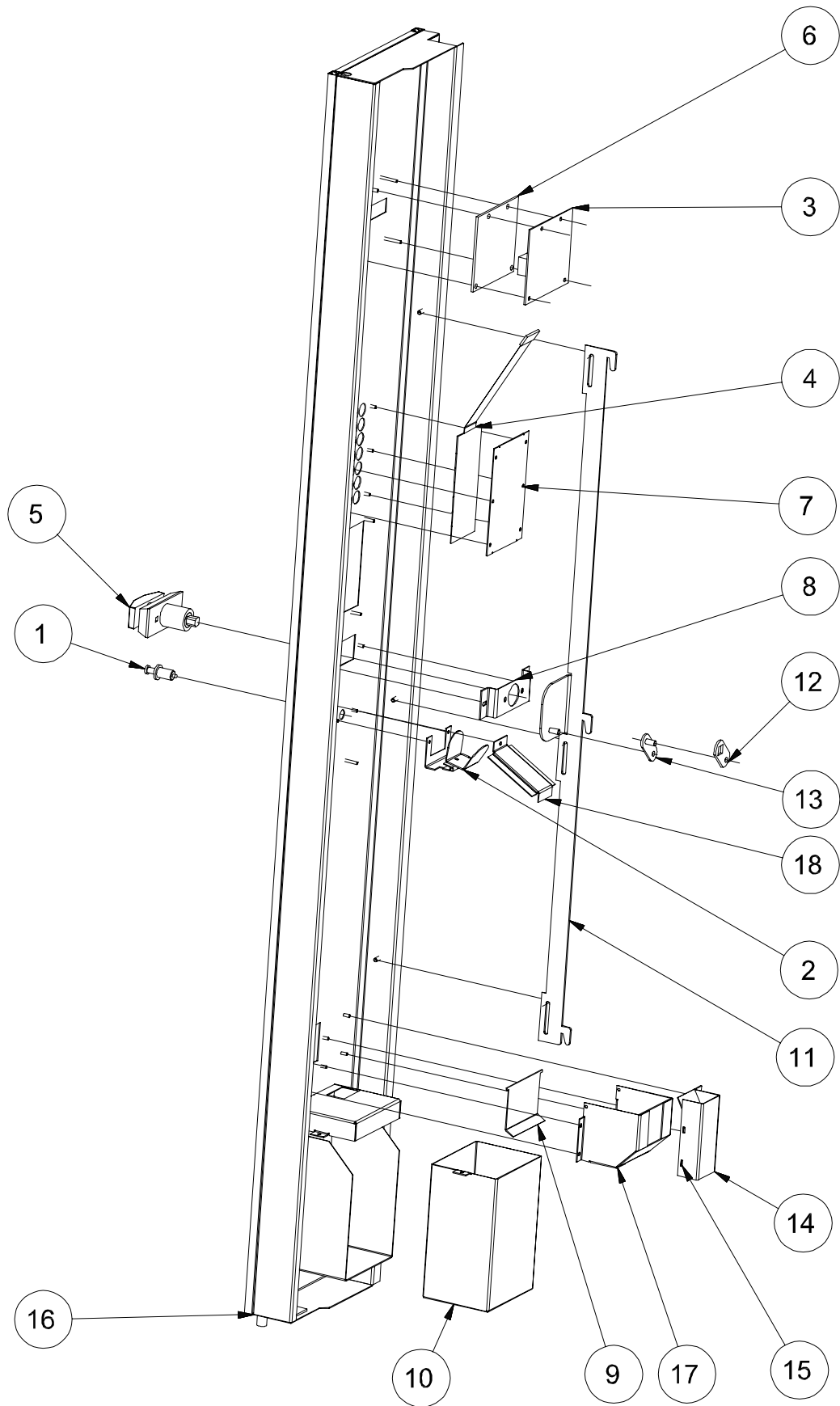

SERVICE DOOR

1	COIN RETURN BUTTON	HA241
2	COIN RETURN ACTUATOR	VC119
3	DISPLAY BOARD	EL734
4	KEYPAD, A THRU L	EL736
5	T-HANDLE	HA247
6	LENS, DISPLAY	PL725
7	KEYPAD BACKPLATE	ST710
8	MOUNT, T-LOCK	ST711
9	COIN RETURN FLAP	ST716
10	COIN OVERFLOW BOX	ST714
11	LOCKBAR, SERVICE DOOR	ST785
12	LINK, T-HANDLE	ST788
13	LINK, LOCKBAR	ST789
14	COIN OVERFLOW BRACKET	ST790
15	COIN OVERFLOW RAMP	ST791
16	SERVICE DOOR	WE120
17	COIN CUP	WE121
18	COIN CHUTE	VC110

FREEZER DOOR AND PRODUCT DOOR

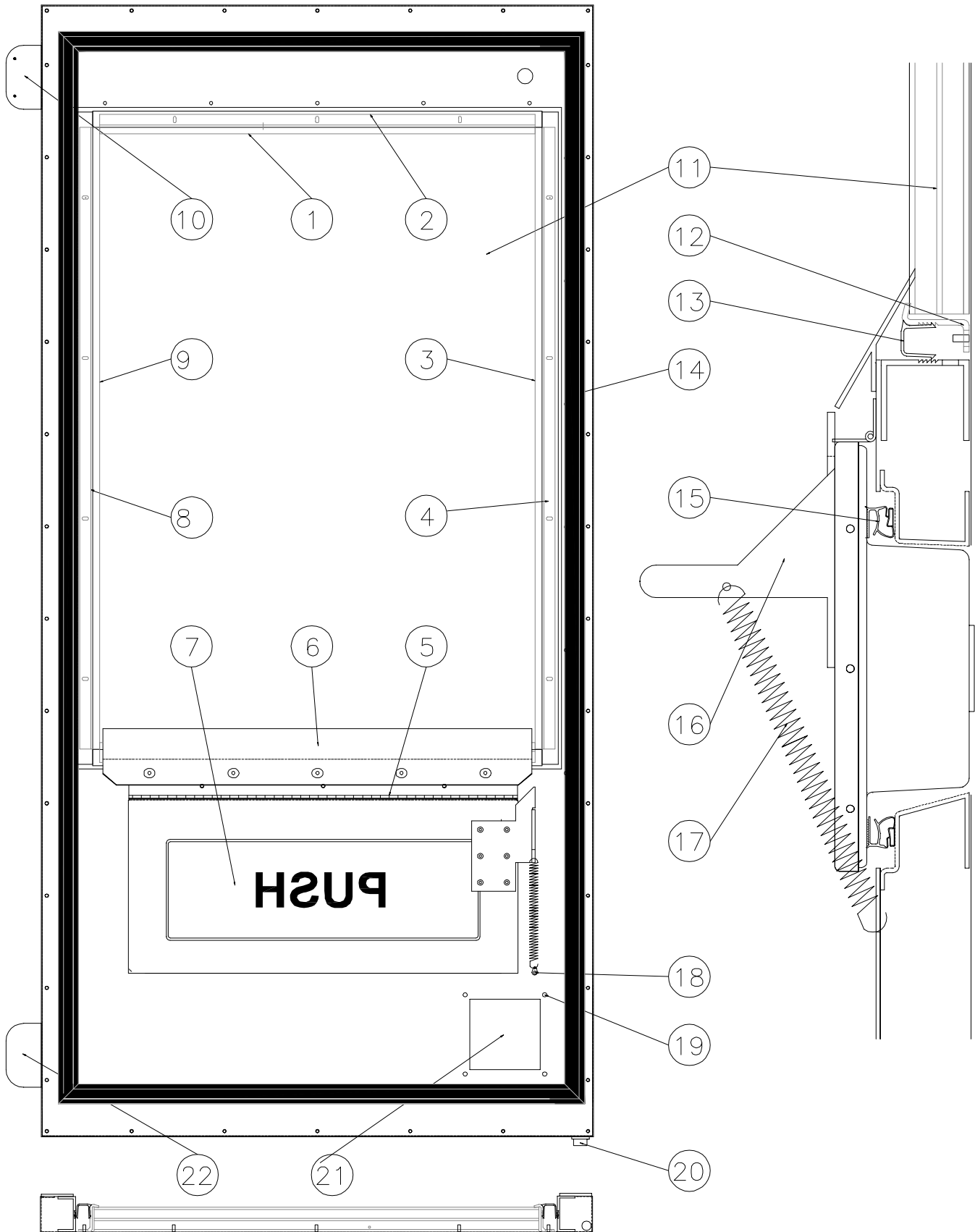

FREEZER DOOR AND PRODUCT DOOR

ITEM NO.	DESCRIPTION	PART NO.
1	FRAME, GLASS, HORIZONTAL, 24.61" LENGTH	PL726
2	BEZEL, SNAP, HORIZONTAL, 25.38" LENGTH	PL729
3	FRAME, GLASS, VERTICAL, 35.25" LENGTH	PL727
4	BEZEL, SNAP, VERTICAL, 37.11" LENGTH	PL728
5	HINGE, PRODUCT DOOR,	HA735
6	PRODUCT DEFLECTOR	PL735
7	ASSEMBLY, PRODUCT DOOR,	SA112
8	BEZEL, SNAP, VERTICAL, 37.11" LENGTH	PL728
9	FRAME, GLASS, VERTICAL, 35.25" LENGTH	PL727
10	LOCK, FREEZER DOOR	ST705
11	GLASS, HTD, 3PANE, 3TEMP, 25.13 X 35.13	GL720
12	FRAME, GLASS, HORIZONTAL, 24.61" LENGTH	PL726
13	BEZEL, SNAP, HORIZONTAL, 25.38" LENGTH	PL729
14	SEAL, FREEZER DOOR	RE721
15	SEAL, PRODUCT DOOR	RE720
16	ACTUATOR, ANTITHEFT	ST724
17	SPRING, PROD DOOR RETAINER	HA720
18	CLIP, SPRING MOUNT, PRODUCT DOOR	FA744
19	RIVET, TREE, NYLON, BLK, 1/4"	FA743
20	BEARING	HA724
21	COVER, WIRING, FREEZER DOOR,	PL723
22	BRACKET, ANGLE, DOOR	ST704

VC1100 CABINET

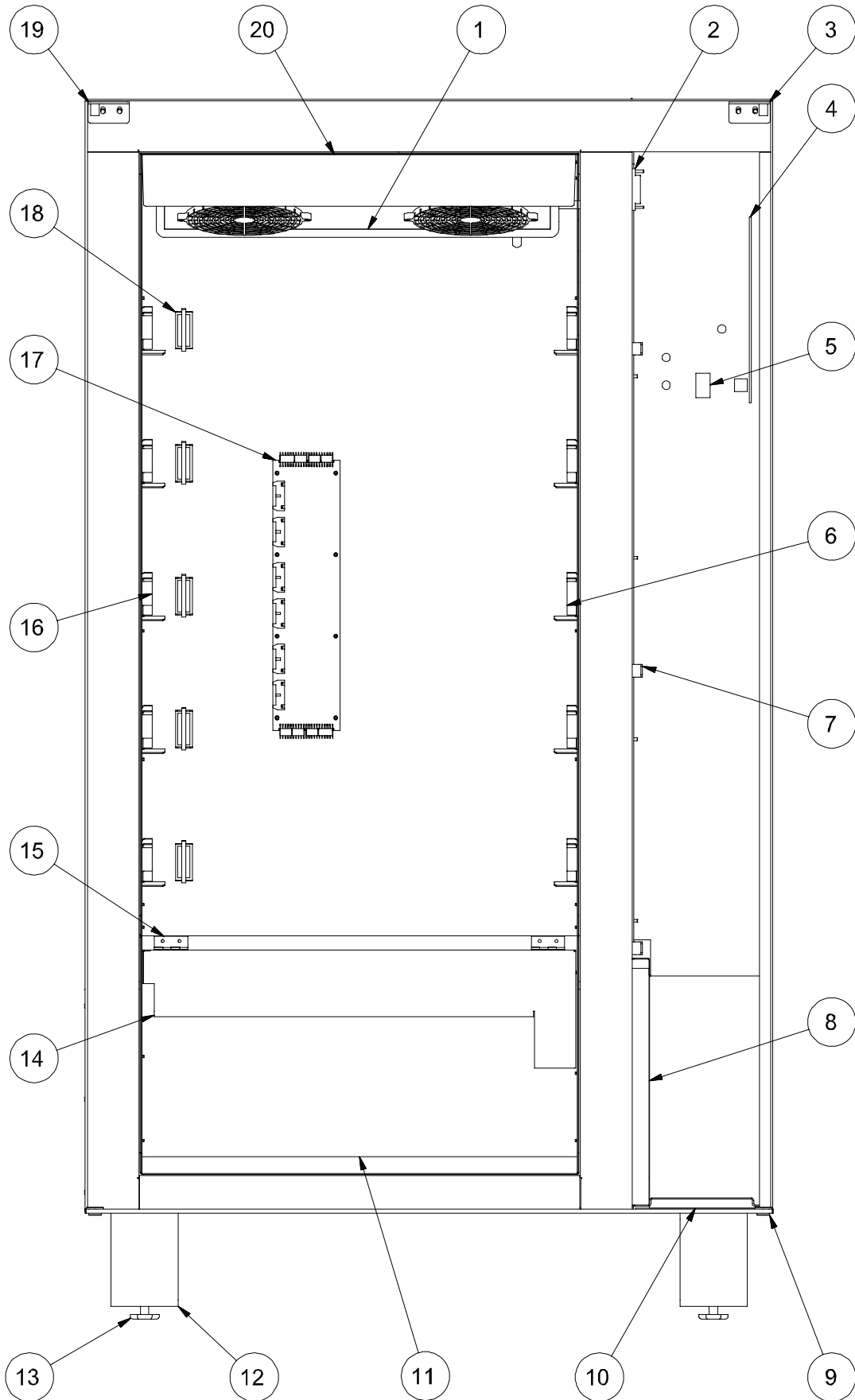

VC1100 CABINET

ITEM NO.	DESCRIPTION	PART NO.
1	EVAPORATOR	RE724
2	SWITCH, MAGNETIC, FREEZER DOOR	EL779
3	SERVICE DOOR MOUNT, TOP, RIGHT	WE101
4	CONTROL BOARD, 120 SELECT, 67196-2	EL733
5	POWER PANEL	PAGE 66
6	RAIL, TRAY, LEFT, TILT	ST734
7	LOCK BAR, CABINET	ST792
8	AIR FILTER, 14x20x1	HA725
9	BEARING	HA724
10	SCREEN, BASE, VC1100, PERF, GALV	ST761
11	FOAM, DROPBOX	IN722
12	LEG, BASE, CABINET	ST797
13	LEVELER	HA723
14	ANTI-THEFT FLAP	WE104
15	HINGE, ANTI-THEFT MOUNT	HA727
16	RAIL, TRAY, RIGHT, TILT	ST735
17	MOTOR INTERFACE BOARD	EL737
18	MOUNT, FLAT, CABLE	FA756
19	FREEZER DOOR MOUNT, TOP, LEFT	WE102

LIGHT FIXTURE, 115V

	LAMP, VC1100, 35W, PHILLIPS	EL761
	LAMPHOLDER, FIXED, LEVITON 465	EL762
	LAMPHOLDER, PLUNGER, LEVITON, 464	EL763
	END CAP, LAMP, 2EACH	EL794
	SLEEVE, LAMP, 20"	EL853
	LEXAN COVER	PL721
	LIGHT HOUSING	PL720

LIGHT FIXTURE, 230V

	LAMP, VC1100, 40W, 840K	EL826
	SOCKET, LAMP	EL824
	RETAINER CLIP, LAMP	HA738
	LEXAN COVER	PL721
	LIGHT HOUSING	PL720

ELECTRICAL PANEL

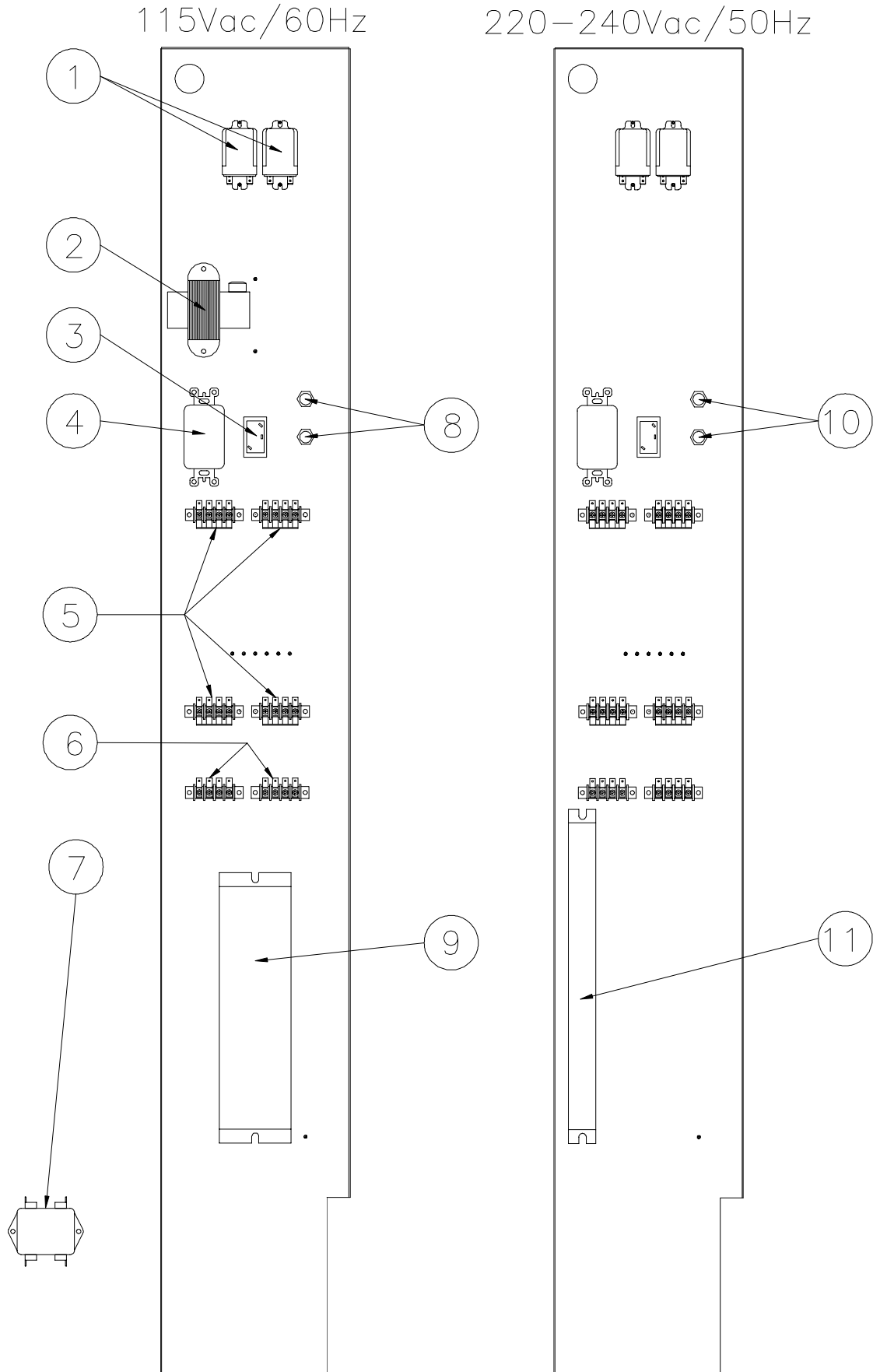

ELECTRICAL PANEL

ITEM NO.	DESCRIPTION	PART NO.
1	RELAY, DPDT, 30AMP, 24VDC,DEL275	EL777
2	TRANSFORMER, CL2, 115-24VAC, 3A	EL778
3	SWITCH, ROCKER, POWER, 20AMP,DPDT	EL766
4	OUTLET, GFCI, 120VAC, 15 AMP	EL757
5	TERMINAL BLOCK, 4-4 JUMPERED	EL797
6	TERMINAL BLOCK, 4-0 JUMPERED	EL796
7	FILTER, LINE, EMI, 120-250AC, 20A	EL764
8	FUSE HOLDER, PANEL MT	EL754
9	BALLAST, VC1100, 35W, 115V	EL753
10	FUSE HOLDER, PANEL MOUNT,CE	EL855
11	BALLAST, VC1100, 40W, 230V,OSRAM, CE	EL856
	TRANSFORMER, 230-115-24, 7 AMP	EL823

CABLE ASSEMBLIES

ITEM NO.	DESCRIPTION	PART NO.
	CA, DISPLAY BOARD, 120MDB	EL740
	CA, VEND MTR HARNESS, TPE, 72"	EL743
	CA, PERIPHERAL INTRF, 120MDB	EL744
	CA, KEYPAD INTERFACE, 120MDB	EL745
	CA, DEX INTERFACE	EL857
	CA, MOTOR INTERFACE, 120MDB	EL739
	CA, REFRIGERATION INTERFACE, 120MDB	EL746
	CA, TEMPERATURE SENSOR, 120MDB	EL747
	CA, ELEC CONNECTOR,FREEZER DOOR,CABINET	EL751
	CA, ELEC CONNECTOR,FREEZER DOOR	EL752
	CA, 2 PIN JUMPER FOR DUAL MOTORS	EL800
	CA, 3 PIN JUMPER FOR DUAL MOTORS	EL799

The following section is provided for general maintenance of the VC1100 vending machine.

Preventative Maintenance

Weekly

- Check for Error codes upon entering the service mode of operations.
- Check the motor count to insure all motors are configured.
- Check the Anti-Theft Mechanism for proper operation.
- Check the air temperature inside the refrigerated space for proper cooling.

Monthly

- Check the air inlet filter located on the left wall of the service compartment.
- Check the air inlet screen located on the base of the service compartment for blockage.
- Check the air outlet screen located on the back of the machine.
- Empty the condensation bottle located in the service compartment.
- Check the Evaporator fans.
- Check the Condenser fan
- Check the heated Glass.

Annually

- Check the condensing coil for obstructions.
- Check the condition of the legs for vandalism.
- Test the defrost cycle for proper operation.
- Lubricate the lockbar and linkages.
- Check the condition of the door seals.

Note: Refer to the specific manufacturer's manual for the coin changer and bill acceptor.

No display on front panel .

1. Transformer fuse bad.
2. Display Board defective.
3. System Control Board defective.
4. Faulty display cable

Selection will not vend.

1. Vend mechanism binding on tray.
2. Product jammed.
3. Tray or motor connector unplugged or faulty connection.
4. Bad motor.
5. System Control Board defective.

Multiple vends from one coil.

1. System Control Board defective.
2. Defective motor switch.

Multiple vends from more than one coil simultaneously.

1. Defective motor.
2. Motor harness not plugged into the vend motor correctly.
3. Tray cable damaged.
4. Defective or damaged Motor Interface board.
5. System Control Board defective.

Unit will not accept money.

1. All prices are set to zero.
2. Will not accept bills if coins in coin changer below minimum.
3. Will not accept more than one bill if bill equals or exceeds the highest priced item.
4. No power to System Control Board.
5. Coin mechanism or bill acceptor defective.

Improper or no change.

1. Out of coins.
2. Bent coins or foreign objects in coin acceptor.
3. Coin mechanism defective.
4. System Control Board defective.

Compressor does not run when main power switch is turned on.

1. Unit not plugged in wall outlet.
2. Building circuit breaker tripped.
3. Defective compressor or starting components.
4. Defective Refrigeration Relay.
5. Cut-out setting higher than the temperature inside the refrigerated space.
6. System Control Board is programmed to disable refrigeration.

Machine will not cool to operating temperature.

1. Dirty condenser filter or air inlet screen.
2. Dirty condenser.
3. Evaporator fans not working.
4. Air leakage or bad door seal.
6. Loss of refrigerant.
7. Ice buildup in the evaporator.

Evaporator fans not running

1. Faulty fan control thermostat inside the evaporator.
2. Glass door switch is out of adjustment or is faulty.
3. Loss of refrigerant.
4. Unit in defrost.

Temperature displays 111°F / 44°C continuously

1. Temperature sensor not connected.
2. P7 connector on the control board not connected
3. System control board failure.

Temperature displays 32°F / 0°C continuously

1. Faulty sensor
2. System control board failure

CAUTION:

High voltages are located in areas of the unit that could cause severe injury or death.

Untrained personnel should only attempt the replacement of the bill acceptor, the coin changer, the front panel display, the System Control Board and vend motors.

The following messages will be affected by the language selection and will be stored in the controller memory to be displayed as described in section 5.

Message #1:

English: "PLEASE INSERT EXACT MONEY"
Italian: "PER FAVORE INTRODURRE I PRECISI SOLDI"
Dutch: "AFGEPAST GELD IN WERPEN"
Spanish: "POR FAVOR DEPOSITE CANTIDAD EXACTA PLEASE INSERT EXACT MONEY"
Danish: "INDKAST AFTALTE PENGE"
French: "FAITES L'APPOINT PLEASE INSERT EXACT MONEY"
German: "ABGEZAHLTES GELD EINWERFEN"

Message #2:

English: "PLEASE INSERT MORE MONEY"
Italian: "PER FAVORE INTRODURRE PIU SOLDI"
Dutch: "MEER GELD IN WERPEN"
Spanish: "POR FAVOR DEPOSITE MAS DINERO PLEASE INSERT MORE MONEY"
Danish: "INDKAST FLERE PENGE"
French: "MONTANT INSUFFISANT INTRODUISEZ D'AUTRES PIECES PLEASE INSERT MORE MONEY"
German: "MEHR GELD EINWERFEN"

Message #3:

English: "MAKE ALTERNATE SELECTION"
Italian: "FARE UNA ALTRE SCELTA"
Dutch: "ANDERE KEUZE MAKEN"
Spanish: "SELECCIONE OTRO PRODUCTO MAKE ALTERNATE SELECTION"
Danish: "VAELG ANDEN VARE"
French: "FAITES UNE AUTRE SELECTION MAKE ALTERNATE SELECTION"
German: "ANDERE WARE WAHLEN"

Message #4:

English: "PLEASE CALL SERVICE"
Italian: "PER FAVORE CHIAMARE SERVIZIO"
Dutch: "SERVICEDIENST BELLEN"
Spanish: "POR FAVOR LLAMAR MANTENIMIENTO PLEASE CALL SERVICE "
Danish: "TILKALD SERVICEMONTOR"
French: "DEMANDEZ LE RESPONSABLE PLEASE CALL SERVICE "
German: "BITTE KUNDENDIENST RUFEN"

Message #5:

ENGLISH: "VENDING OPERATION TO RESUME AT hh.mm "
Italian: "VENDING OPERATION TO RESUME AT hh.mm "
Dutch: "VENDING OPERATION TO RESUME AT hh.mm "
Spanish: "VENDING OPERATION TO RESUME AT hh.mm "
Danish: "VENDING OPERATION TO RESUME AT hh.mm "
French: "VENDING OPERATION TO RESUME AT hh.mm "
German: "VENDING OPERATION TO RESUME AT hh.mm "

Message #6:

English: "MAKE SNACK SELECTION ONLY"
Italian: "DISPONIBILI SOIO LE SELEZIONI SNACK"
Dutch: "ALLEEN SNACK KEUZES"
Spanish: "SOLO DISPONIBLE PRODUCTOS EN ESPIRAL MAKE SNACK SELECTION ONLY "
Danish: "KUN VALG AF KONFEKTURE MULIGT"
French: "CHOISISSEZ UNIQUEMENT LES CONFISERIES MAKE SNACK SELECTION ONLY "
German: "NUR AUSGABE VON SUSSWAREN MOGLICH"

Message #7:

English: "THANK YOU"
Italian: "GRAZIE"
Dutch: "DANK U"
Spanish: "GRACIAS"
Danish: "TAK"
French: "MERCI"
German: "VIEL. DANK"

Message #8:

English: "FREE ON US"
Italian: " FREE *"
Dutch: " FREE *"
Spanish: " FREE *"
Danish: " FREE *"
French: " FREE *"
German: " FREE *"

DEX/UCS RECORD SUBSET

DEX field	DEX field description; Explanation
ID101	MACHINE SERIAL NUMBER
ID102	MACHINE MODEL NUMBER
VA101	VALUE OF ALL PAID SALES SINCE INITIALIZATION
VA103	VALUE OF ALL PAID SALES SINCE LAST RESET
CA302	VALUE OF CASH TO COIN BOX SINCE LAST RESET
CA303	VALUE OF CASH TO TUBES SINCE LAST RESET
CA304	VALUE OF BILLS IN SINCE LAST RESET
CA401	VALUE OF CASH DISPENSED SINCE LAST RESET
CA402	VALUE OF CASH MANUALLY DISPENSED SINCE LAST RESET
CA801	VALUE OF CASH OVERPAY SINCE LAST RESET
CA1001	VALUE OF CASH FILLED SINCE LAST RESET
CA1401	BILL VALUE,(\$1, 2, 5, 10, & 20)
CA1403	NUMBER OF BILLS TO STACKER SINCE LAST RESET
TA201	VALUE OF VEND TOKEN SALES SINCE INITIALIZATION(FREE TOKEN NO VALUE)
TA202	VALUE OF VEND TOKEN VENDS SINCE INITIALIZATION(FREE TOKEN NO VALUE)
TA203	VALUE OF VEND TOKEN SALES SINCE LAST RESET
TA204	NUMBER OF VEND TOKEN VENDS SINCE RESET
TA205	VALUE OF VALUE TOKEN SALES SINCE INITIALIZATION
TA206	NUMBER OF VALUE TOKEN VENDS SINCE INITIALIZATION
TA207	VALUE OF VALUE TOKEN SALES SINCE LAST RESET
TA208	NUMBER OF VALUE TOKEN VENDS SINCE INITIALIZATION
TA301	VALUE OF VALUE TOKENS IN SINCE LAST RESET
TA302	VALUE OF VALUE TOKENS IN SINCE INITIALIZATION
PA101	PRODUCT NUMBER
PA102	PRODUCT PRICE
PA201	NUMBER OF PRODUCTS VENDED SINCE INITIALIZATION
PA203	NUMBER OF PRODUCTS VENDED SINCE LAST RESET
PA204	VALUE OF PAID PRODUCT SINCE LAST RESET
PA303	NUMBER OF TEST VENDS SINCE LAST RESET
EA201	EVENT IDENTIFICATION; ONE FREE PRODUCT VENDS
EA202	NUMBER OF EVENTS SINCE LAST RESET
EA204	USER DEFINED FIELD; VALUE
EA201	EVENT IDENTIFICATION; PROMO VENDS
EA202	NUMBER OF EVENTS SINCE LAST RESET
EA204	USER DEFINED FIELD; VALUE
EA201	EVENT IDENTIFICATION; TUBE VALUE (.05, .10,.25, 1.00)
EA204	USER DEFINED FIELD; VALUE
EA201	EVENT ID; VALUE OF BILLS & CASH BOX SINCE LAST RESET
EA204	USER DEFINED FIELD; VALUE
EA301	NUMBER OF READS SINCE INITIALIZATION
EA302	DATE OF THIS READ OUT
EA303	TIME OF THIS READ OUT
EA304	THIS TERMINAL/INTERROGATOR IDENTIFICATION
EA305	DATE OF LAST READ OUT
EA306	TIME OF LAST READ OUT
EA307	LAST TERMINAL/INTERROGATOR IDENTIFICATION
EA501	DATE OF PRICE SETTING
EA502	TIME OF PRICE SETTING