



INFINITY

4-Wide and 5-Wide
Ambient and Refrigerated models

SERVICE and PARTS MANUAL



INTRODUCTION

Congratulations on the purchase of your vending machine. This vending machine has been designed to give you many years of dependable service. It requires little maintenance and is easy to set up and operate.

READ THIS MANUAL COMPLETELY

Your vending machine is designed to operate simply and reliably, but to take full advantage of your vendor, please read this owner's manual thoroughly. It contains important information regarding installation and operations, as well as a brief trouble-shooting guide.

EQUIPMENT INSPECTION

After you have received your vendor and have it out of the box, place it on a secure surface for further inspection. **Note:** Any damages that may have occurred during shipping must be reported to the delivery carrier immediately. Reporting damages and the seeking of restitution is the responsibility of the equipment owner. The factory is willing to assist you in this process in any way possible. Feel free to contact our Customer Care Department with questions you may have on this process.

It is important that you keep the original packaging for your vending machine at least through the warranty period. If your machine needs to be returned for repair, you may have to purchase this packaging if it is not retained.

Once you have your vendor located, we suggest that you keep this manual for future reference, or you can view this manual online at www.seaga.com. Should any problems occur, refer to the section entitled "TROUBLESHOOTING". It is designed to help you quickly identify a problem and correct it.



SECTION 1**SPECIFICATIONS****US Version 115 V**

Specifications	4 Wide		5 Wide	
	Ambient	Refrigerated	Ambient	Refrigerated
Height	72"	72"	72"	72"
Width	35"	35"	39"	39"
Depth	37"	37"	37"	37"
Floor Space	8.75 Sq. Ft.	8.75 Sq. Ft.	9.75 Sq. Ft.	9.75 Sq. Ft.
Packing Size	56.27 Cu. Ft.	56.27 Cu. Ft.	62.53 Cu. Ft.	62.53 Cu. Ft.
Voltage (AC)	115V	115V	115V	115V
Hertz	60Hz	60Hz	60Hz	60Hz
Running Amperes	1Amp	8Amp	1Amp	8Amp
Watts	115 Watts	920 Watts	115 Watts	920 Watts
Refrigerant Type	-	134a	-	134a
Refrigerant Charge	-	300 Grms.	-	300 Grms.
Shipping Weight	470 lbs.	703 lbs.	528 lbs.	764 lbs.

EU and India Version, 230 V

Specifications	4 Wide			5 Wide	
	Ambient	Refrigerated	Lite	Ambient	Refrigerated
Height	184 cm	184 cm	184 cm	184 cm	184 cm
Width	89 cm	89 cm	89 cm	99 cm	99 cm
Depth	93 cm	93 cm	73 cm	93 cm	93 cm
Floor Space	0.81 S Mtr	0.81 S Mtr	0.65 S Mtr	0.90 S Mtr	0.90 S Mtr
Packing Size	1.59 Cu Mtr	1.59 Cu Mtr	1.43 Cu Mtr	1.77 Cu Mtr	1.77 Cu Mtr
Voltage (AC)	230V	230V	230V	230V	230V
Hertz	50Hz	50Hz	50Hz	50Hz	50Hz
Running Amperes	1Amp	5Amp	5Amp	1Amp	5Amp
Watts	220 Watts	1150 Watts	1150 Watts	230 Watts	1150 Watts
Refrigerant Type	-	134a	134a	-	134a
Refrigerant Charge	-	350 Grms.	350 Grms.	-	350 Grms.
Shipping Weight	317 kg	319 kg	298 kg	239 kg	347 kg

PHYSICAL CHARACTERISTICS

- Finish : Powder Coat paint
- Compliant with US ADA standards for vending equipment.

ENVIRONMENT

- Indoors only; Infinity Xtreme versions available from your Seaga distributor for outdoor use.

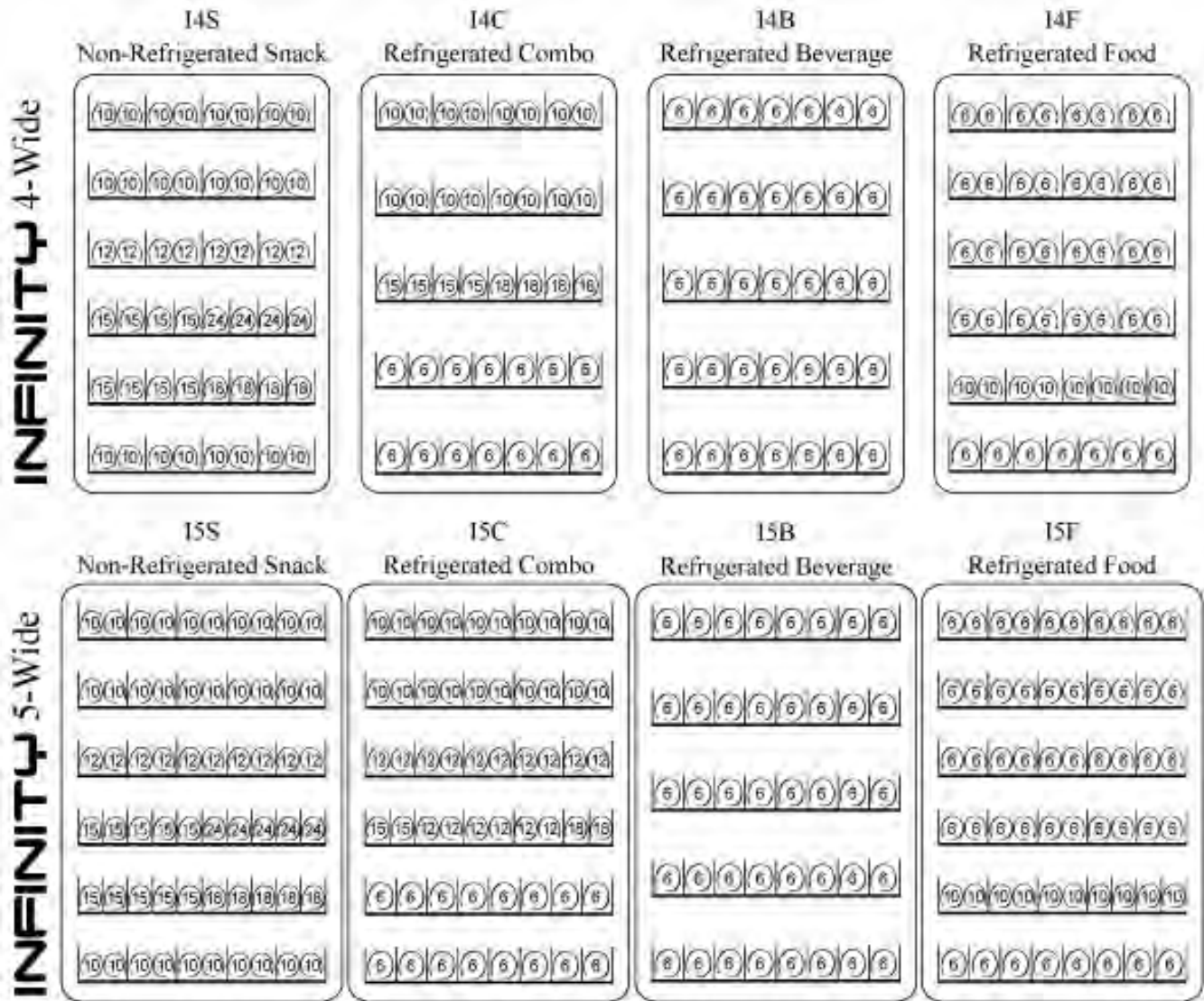
ELECTRICAL REQUIREMENT

US version requires one (1) 115 VAC 12 Amps grounded outlet.
 EU version requires one (1) 230 VAC 12 Amps grounded outlet.

STANDARD COIL CONFIGURATION

Custom configurations available.

Our standard configuration is subject to change without notice to keep up with market and location demand for new products.



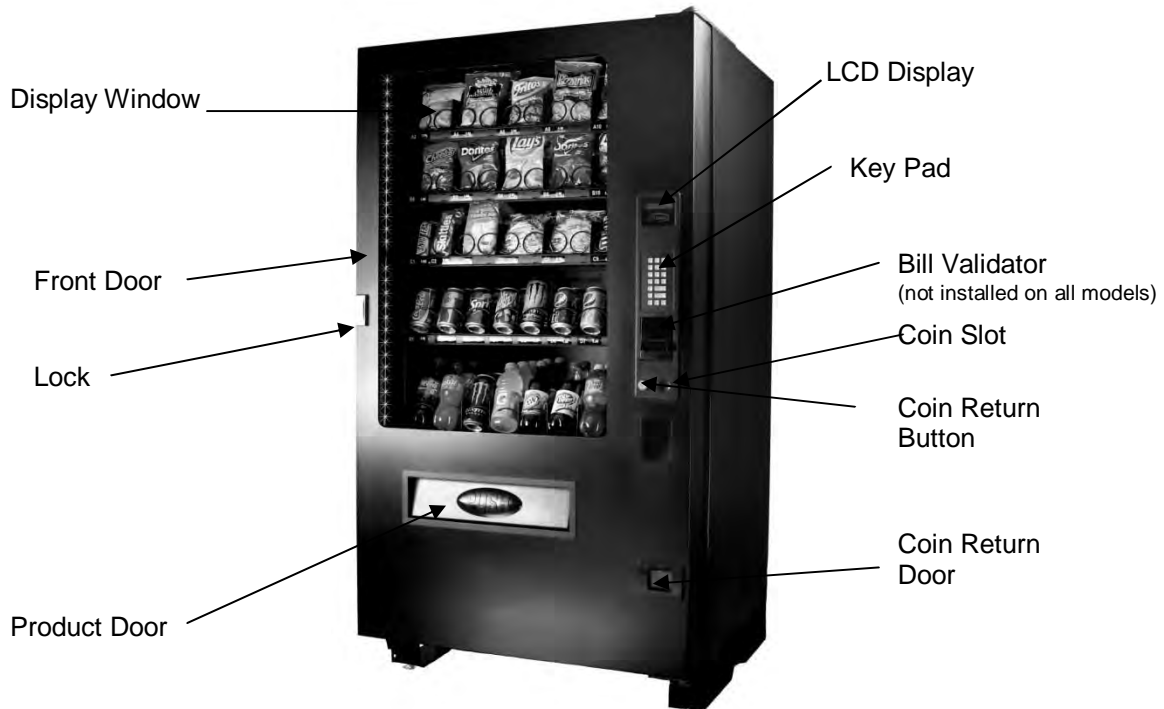
CAUTION: Certain procedures described in this manual require electrical power to the vending machine. Only trained personnel should perform these functions. Use extreme caution while performing the procedures marked with the voltage symbol shown here:



CAUTION: Certain procedures described in this manual require a qualified, trained technician to perform the particular task at hand. These procedures will be marked with the attention symbol shown here:

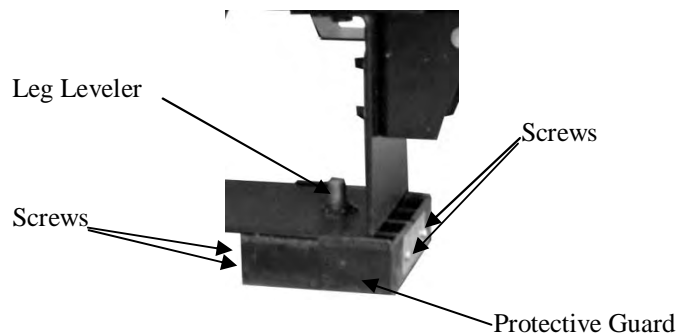


Fig. 1 - Exterior View (I5C 5-Wide Combination Machine Shown)



Protective shipping guards (Fig. 2) were installed on the leveling legs at the factory. Once the machine is placed near its final location the protective shipping guards should be removed. To remove the shipping guard, unscrew the leveling leg from the bottom until the guard is loose – a few turns only. The guard is held together with four phillips head screws and two brackets. Remove the screws and the guard will split in half for removal.

Fig. 2 – Shipping Guards



Now place the machine into its final location. Using a level on the top of the machine, adjust the leveling legs for proper level both side to side and front to back. A good point to keep in mind is the shorter the leveling legs are kept to achieve proper leveling, the more stable the machine will be.

Proper leveling is also necessary to allow easy opening and closure of the vending machine door and to insure proper vending operation.

Fig. 3 - Leg Levelers

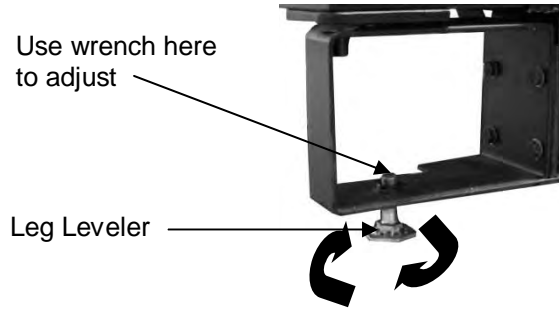
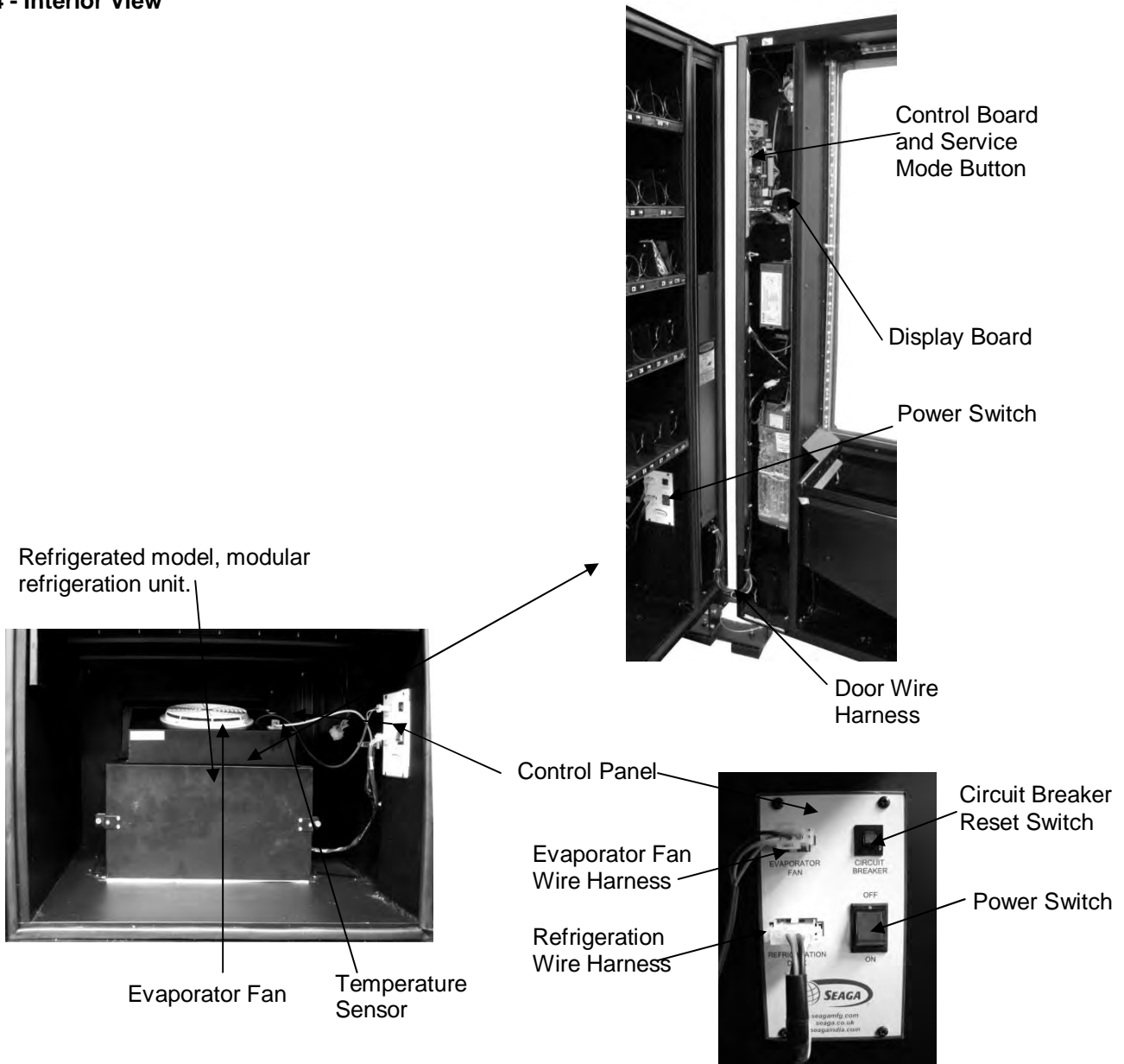


Fig. 4 - Interior View



SECTION 2

INSTALLATION

CAUTIONS



Your vendor is intended for indoor use only.

Excessive heat, cold or humidity levels will void your warranty; install only in climate controlled, indoor environments. For indoor machines the temperature range must be no higher than 32°C/90°F and no lower than 10°C/50°F with a relative humidity (Rh) level of no greater than 40%.

Your vendor must be set on a level, well-supported location.

Always unload vendor before transporting it.

Remove all wire ties and protective sheeting prior to vending.



CAUTION!

It is important that this machine is hooked up to the proper voltage. Verify the voltage before connecting the machine to a wall outlet.



CAUTION!

Different countries may have different power arrangements. Insure that the machine is properly grounded before operating.



CAUTION!

If the power cord is damaged, it must be replaced by the manufacturer, authorized service agent or a similarly qualified person to avoid electrical hazards.



ATTENTION!

This vending machine is very heavy. Ensure that sufficient personnel are available for lifting or transporting the machine. Use proper lifting procedures and equipment.



CAUTION!

Certain components of this machine are sensitive to static electricity. Precautions for handling sensitive devices should be observed when handling these items.



ATTENTION!

Refrigerated models need air flow. Leave at least 6" (15 cm) between the back of the vending machine and the wall. Condenser cooling air is taken in the bottom and exhausted out the back of the machine. Clean the condenser once every two weeks or more often for dusty or dirty locations.

DOOR CLEARANCE

Allow 7" (18 cm) of clearance on the right side of the machine for the door to open and extend past the cabinet side. See also the clearance requirements in Section 2 for refrigerated units.

LOADING PRODUCTS

To present your product in as an attractive and professional manner as possible, do not load any damaged items, and make sure items are facing forward for easy identification by your customer.

Note: The size of the item being vended must be larger than the Helix Coil, but smaller than the Product Column to vend correctly. Never force an oversized item into the Helix Coil or Product Column, nor attempt to vend an item that is smaller than the Helix Coil as this will create problems and deter customers. (Fig.5)

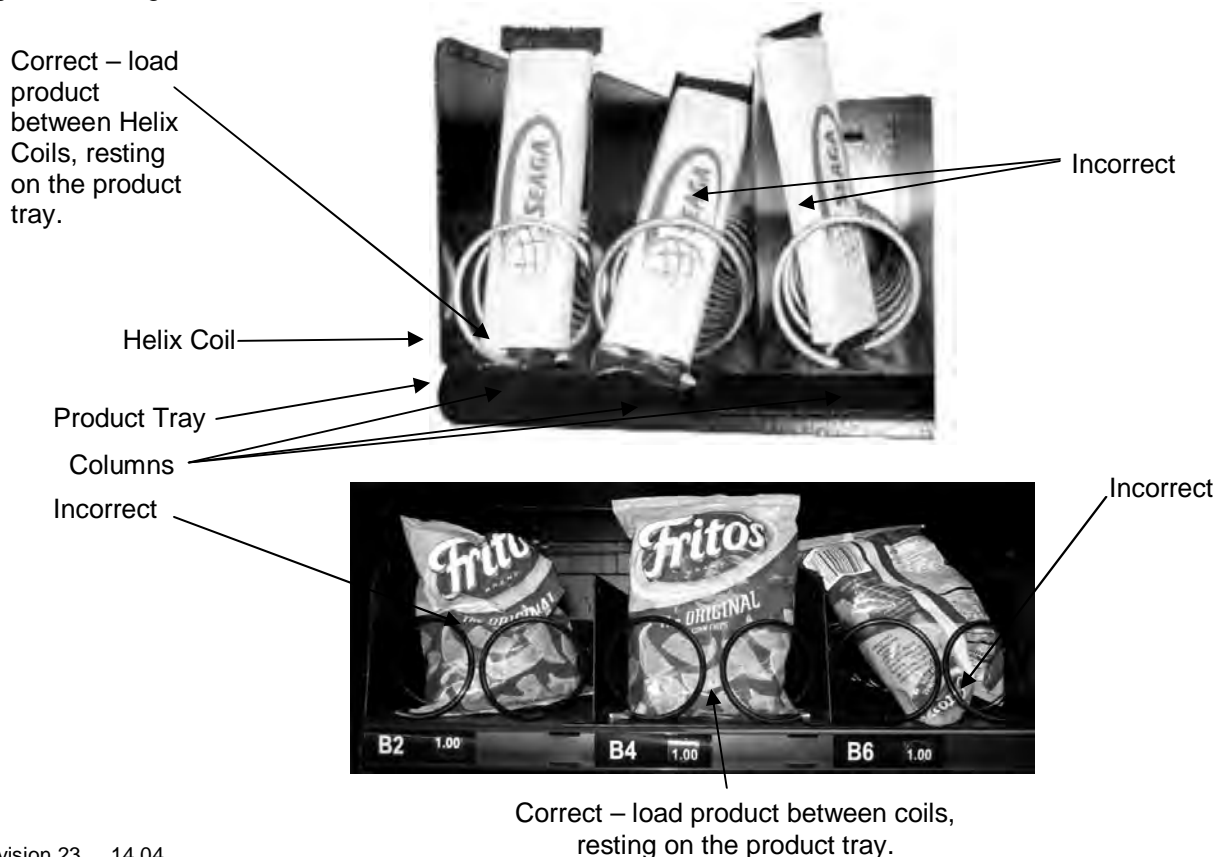
1. To Load Product:

- A.) Push down and hold the release latch located on the right side of the tray and slide the desired Product Tray toward you, all of the way forward. Product Tray will tilt down or can be removed and placed on the floor or a table. **Note: Pull out only one (1) Product Tray at a time. Beverage trays do not tilt for loading!**
- B.) Place product in proper size Helix Coil. Note: Bottom of product must rest on the Product Tray and not on the Helix Coil. (Fig. 5) Load each Product Chute from front to back. Note: Do not leave any spaces between items.
- C.) Once Product Tray is loaded, lift the front of the tray to level and push it back in. Repeat above steps until all Product Trays are fully loaded.
- D.) After loading the product, if you have removed the tray to do so, place the Tray in the cabinet by aligning the wheels in the guide rails. Clear the wire harness to the side so that it is not interfering with the tray below.

To increase the length of the Helix Coil, plastic Product Pushers can be snapped on the end. Product Pushers can be purchased from Seaga's Customer Care team.

Note: We suggest that you always partially fill the vendor with product and perform at least five (5) test vends. Test vends can be performed easily by entering Service Mode and using the Diagnostics/Motors to select the selection to test.

Fig. 5 – Loading Helix Coils



PRODUCT PUSHERS

Product pushers assist in moving the top of the product forward while it is being vended on the bottom, helping it fall smoothly from the shelf. Product pushers are also good for products that have the wrapper flaps on the ends of the package. Packaging such as this benefits from the extra momentum from the product pushers to keep the flaps from hanging up the product on the spiral. Product pushers are available from Seaga's Customer Care and Parts department. The pusher is installed approximately ½ inch (1.5 cm) from the end of the coil with the tab extending forward (see Fig. 6). Locate the pusher in its proper position, hold it against the coil wire and push the semi-circular part around the coil wire. Note: Boxed items will not need a product pusher.

Figure 6 – Product Pusher Installation



LOADING BAGGED OR BOXED ITEMS

Vending small bagged items in the 8 or 10 selection trays can be a problem when the products are not loaded properly. The flap edges of some products may get trapped under the spiral and cause the product to “hang up”. It is recommended that the bottom flap of this type of packaging be folded forward and up (Fig. 5) next to the product when loading. This type of packaging also lets the product settle to the bottom, so using the wider spirals is also recommended.

LOCK

Your vendor has one Lock, more commonly known as T-handle lock. To unlock the front door, insert key and turn clockwise ¼ turn. When unlocked the ‘T’ of the Lock will pop out from its base. Turn the ‘T’ counter clock wise to unlock the door. To Lock the door, firmly close the door and turn the ‘T’ handle clockwise 1 to 2 times and then pull on the door to test that the lock has engaged. If so, then push the ‘T’ inside the Lock to lock the door and remove the key. Note: Do not over-tighten when locking – this could strip the threads and damage your machine.

REFRIGERATION

If you purchased a refrigerated model, please see special information throughout the manual regarding refrigeration, settings and other information. The refrigeration system consists of a Compressor, Relay Circuit, Accumulator, Condenser, Condenser Fans, Evaporator, Evaporator Fan and Air Duct. The entire refrigeration system is modular and has a separate internal power cord, which is plugged into the panel provided at the lower area below the bottom tray. The power switch has to be turned ON in order to start up the refrigeration system. There is a door switch that controls the refrigeration system ON and OFF condition. When the door is opened, the door switch is not depressed and the refrigeration system shuts OFF. When the door is closed, the switch is activated and the evaporator fan starts turning. There will be a delay of a few seconds before the compressor starts running after the door closure.

There is a vent on the cabinet back to blow the air from condenser. The inlet vent is at the bottom of the cabinet in front of the condenser. The condenser has to be cleaned regularly. The recommended frequency is once every two weeks. There are 2 thumb screws around the front of the refrigeration module that have to be unscrewed in order to remove the front door of the refrigeration module. This will provide the access to the condenser. Using a vacuum cleaner or a brush, clean the lint in between the condenser fins. Note: Be careful not to bend the fins – this could restrict airflow and damage your machine.

The compressor and the relay circuit, condenser fan motor and drain pan can be accessed in the same manner by removing the front door. The refrigeration system has to be unplugged and the module has to slide completely outside in order to gain access to these components.

NOTE: When moving the vending machine, care must be taken to never tilt the unit more than 20° in any direction. After moving, DO NOT plug the unit in to power so that the compressor system oils are allowed to settle. Failure to heed these instructions can cause severe damage to your vending machine and void your warranty.

REFRIGERATION STATUS DISPLAY

Use the “10” key on the Keypad to display the following indications of the refrigeration system on the LCD Display:

Figure 7 – Refrigeration Indicators on LCD Display



Delayed Start Mode – door switch is not being engaged; compressor will not start in this mode.



Cooling Mode – Door switch is engaged and compressor is active. The machine is cooling but not yet at operating temperature.



Defrost Mode – Machine is in defrost cycle. Defrost cycle time can be set using the Advance menu option Auto-Defrost in Diagnostics.



Zone 1: Zone 1 is active on the machine. Your SP series machine should only use Zone 2. Shut off Zone 1 in the diagnostics mode using the Advanced submenu.



If there are no indicators on the display, the machine is at the operating temperature.

SECTION 3

OPERATION

DISPLAY

The LCD Display (Fig. 8) is a two line, 20 character text display panel located on the front of your vending machine. The display shows the customer the amount of money entered into the vendor and the cost of their selection among other information as programmed. It shows the operator the Service Mode functions for setting the various functions of the vendor.

Fig. 8 – LCD Display



SERVICE MODE



Navigation of the Service Mode Menu

BUTTON	FUNCTION
↑ Button	This key is used to increase a numeric value, or move forward through the various service mode functions.
↓ Button	This key is used to decrease a numeric value or move backwards through the various service mode functions.
F Button	This key is used to confirm, accept, or ENTER into a service mode function.
G Button	This key is used to EXIT the service mode or a service mode function.

ENTERING SERVICE MODE

To enter into service mode, open the vendor door and Press the Menus Button (Fig. 10). After pressing the Service mode switch the controller will beep twice and the display will change to show **“Service Menu”** on the first line and **“Prices”** on the second line (Fig. 10). At this time you can use the keypad on the front of the machine to move through the various service mode MENUS.

Fig. 9 - Service Mode Button

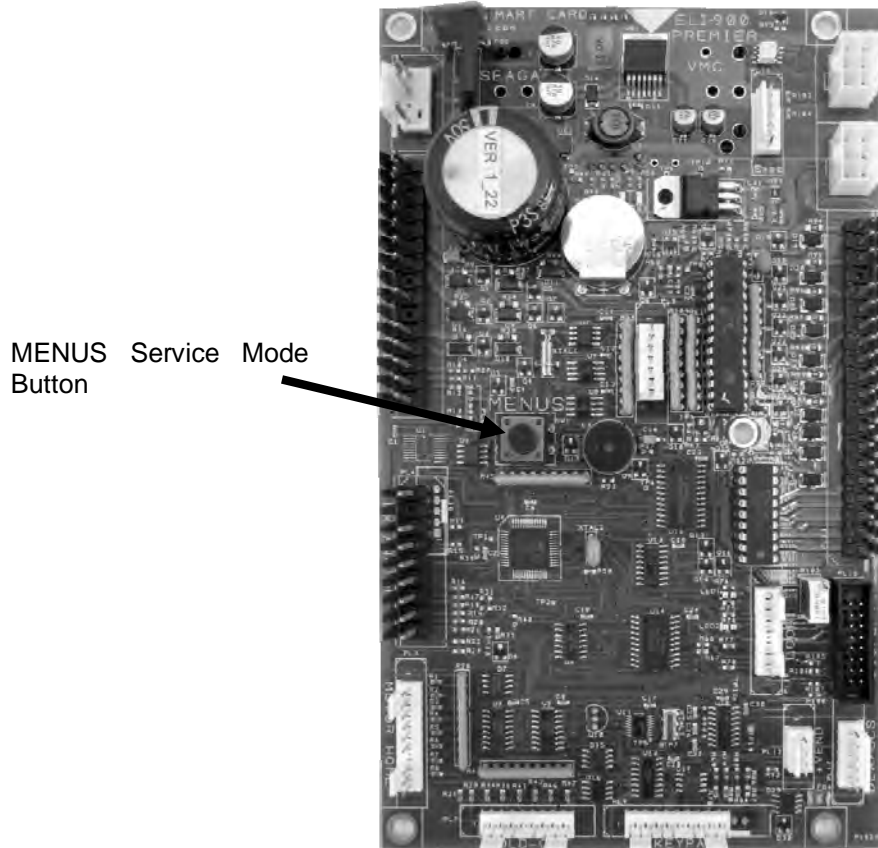


Fig. 10 – LCD Display while in Service Mode. The Prices menu is the first sub-menu.



TO EXIT SERVICE MODE

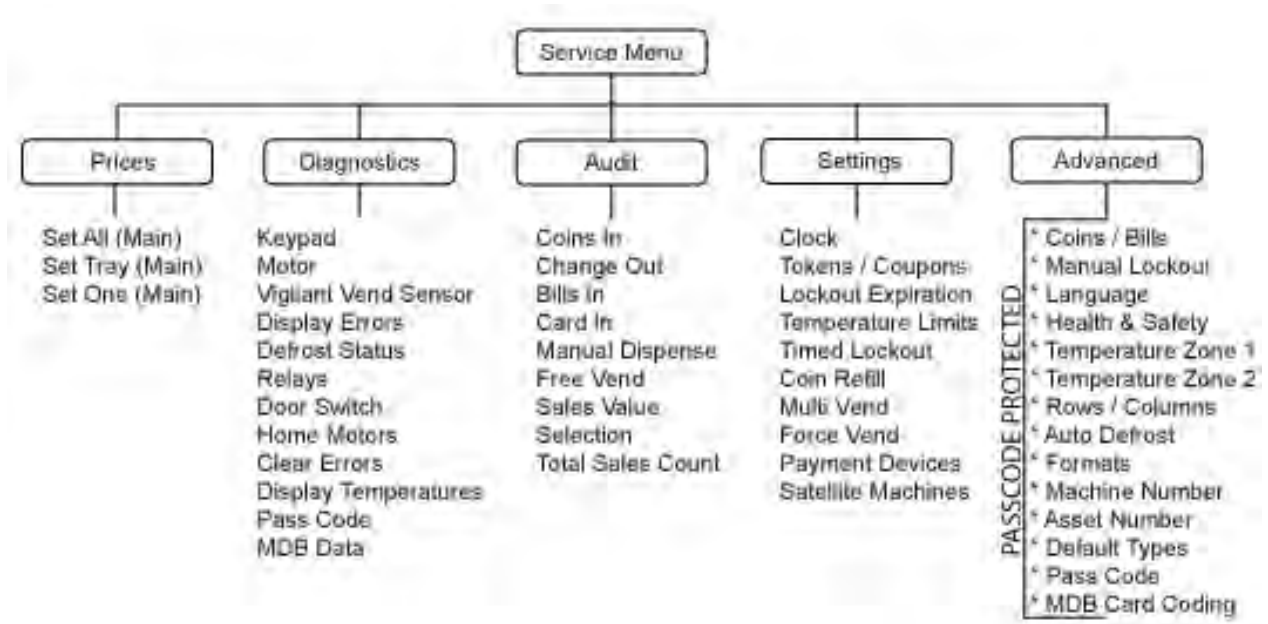
The controller will remain in service mode as long as the user keeps using the keypad to move through the various service mode MENUS. The controller will automatically exit service mode and return to sales mode if any of the following occur:

- 1) The user is inactive for more than 1 minute
- 2) The user presses the EXIT key (G).

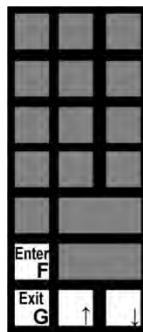
After exiting the service mode, the installed firmware version shows on the display for three seconds, then the controller will revert to sales mode.

SERVICE MODE MENUS

The chart below shows the sub-menus while in Service mode:



In the following instructions, refer to the drawing of the four button navigation key drawing on the left side of the page. Follow the arrows, paying attention to the navigation instructions (F), (G), (↑) and (↓)

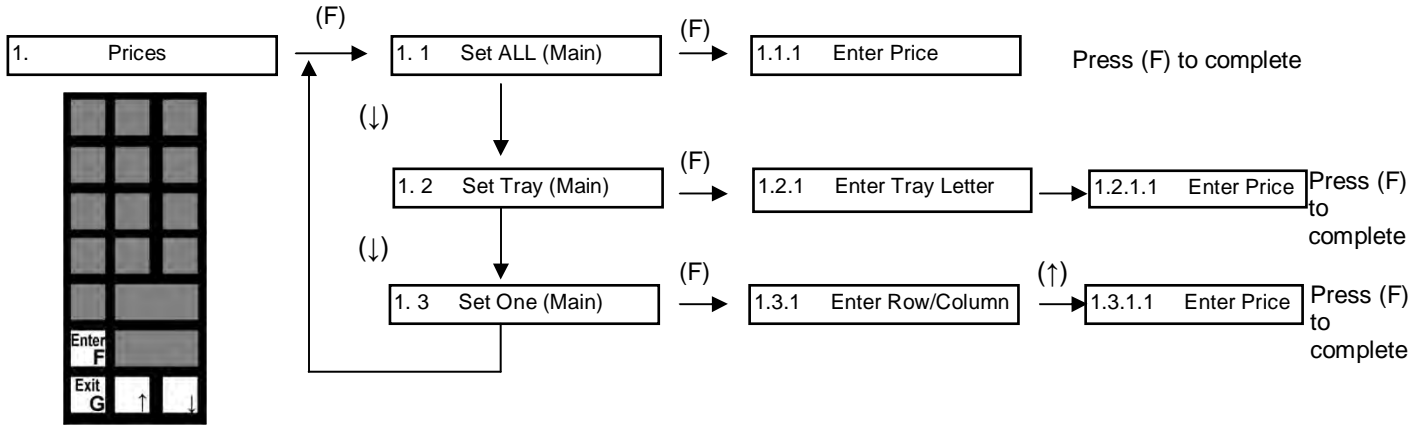


PRICES SUB-MENU

The Prices sub-menu allows you to set prices in three different ways – Set ALL, Set ONE, Set Tray. Set ALL will allow you to set all of selections in the machine to the same price. Set ONE will allow you to set one individual selection of your choosing. Set Tray will allow you to set an entire tray to the same price.

Using these available options will save you time – if the majority of your price is, for example, set at \$1, use the Set ALL sub-menu to set all prices to \$1. You can then go back and set individual prices for certain selections as needed.

In order to enter the price, Press the corresponding number. For example, if the Price of a Selection is \$0.75, then Press “7” and “5”. Press F to accept the value; G to exit to the main menu. *Note: Discount prices can only be set using a Seaga Smart Card.*



DIAGNOSTICS SUB-MENU

Diagnostics - The Diagnostics menu is used to test various features of the machine. Certain critical features of the machine are protected by a pass code provided to the operator to prevent inadvertent modifications to the machine.

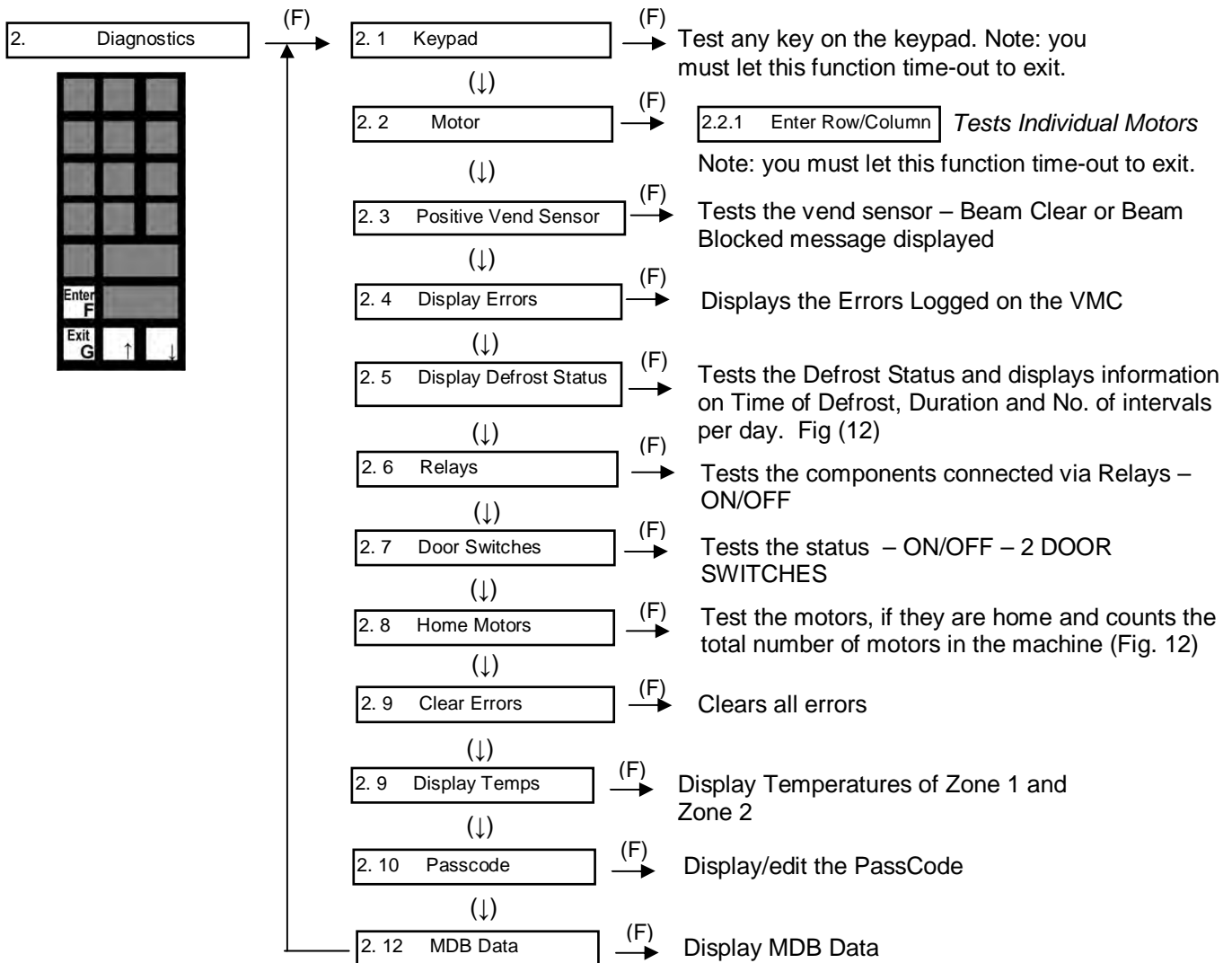


Fig. 11

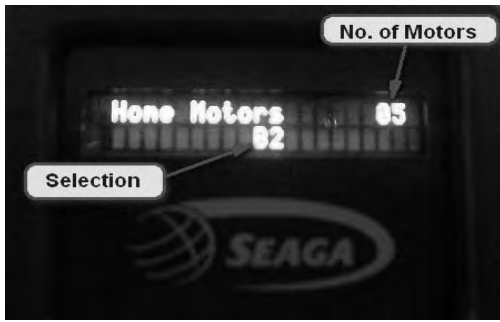
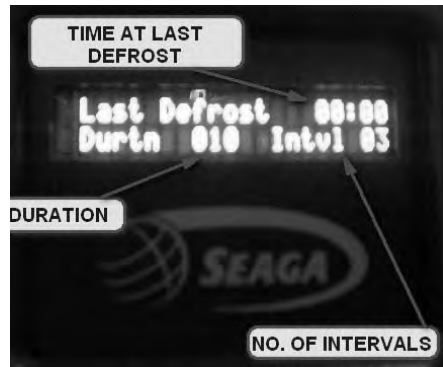
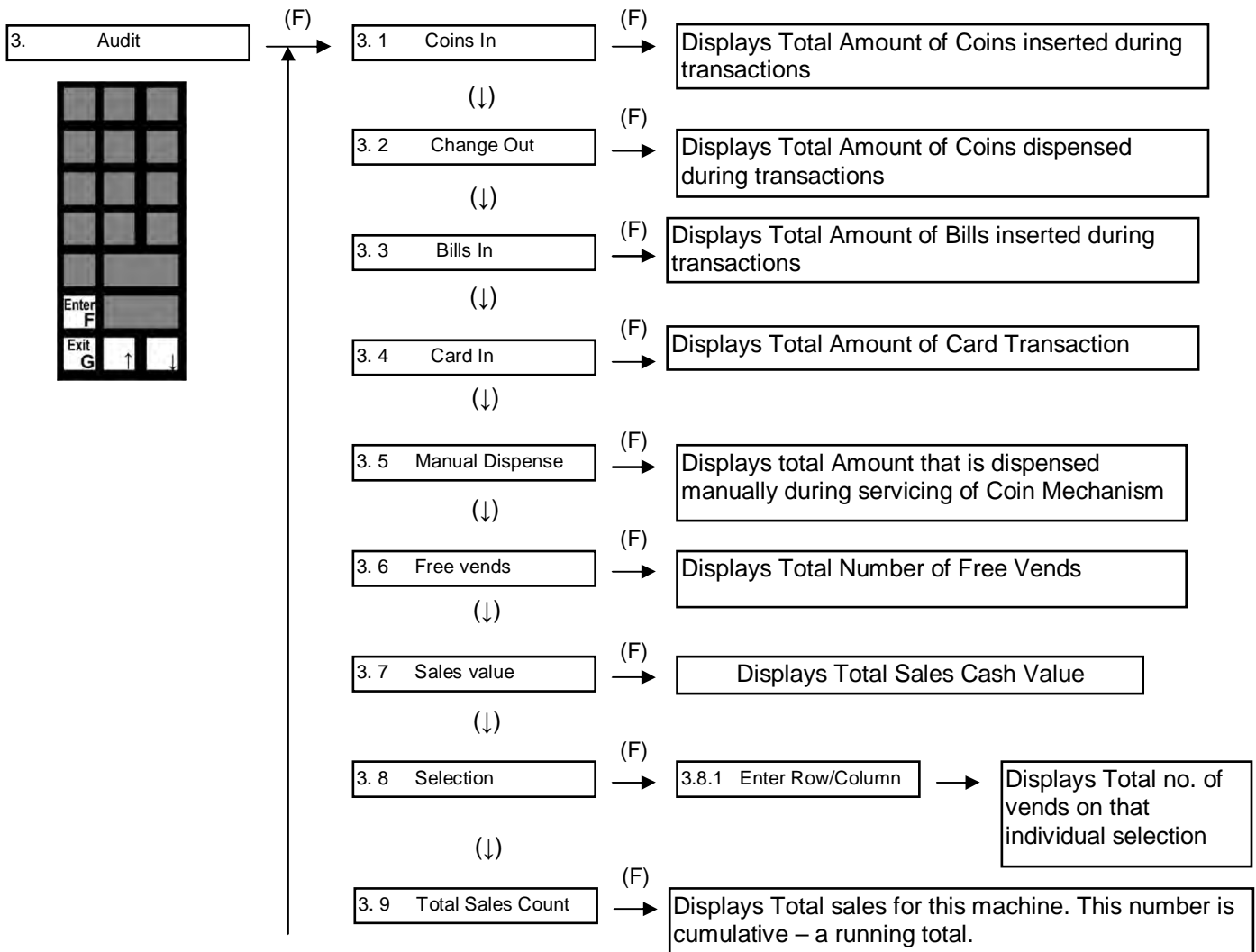


Fig. 12



AUDIT SUB-MENU

AUDIT MENUS -The Audit Menu is used to track the machine operation in all aspects but not limited to the transactions.



SETTINGS SUB-MENU

SETTINGS - This menu is used to Setup the features of the machine.

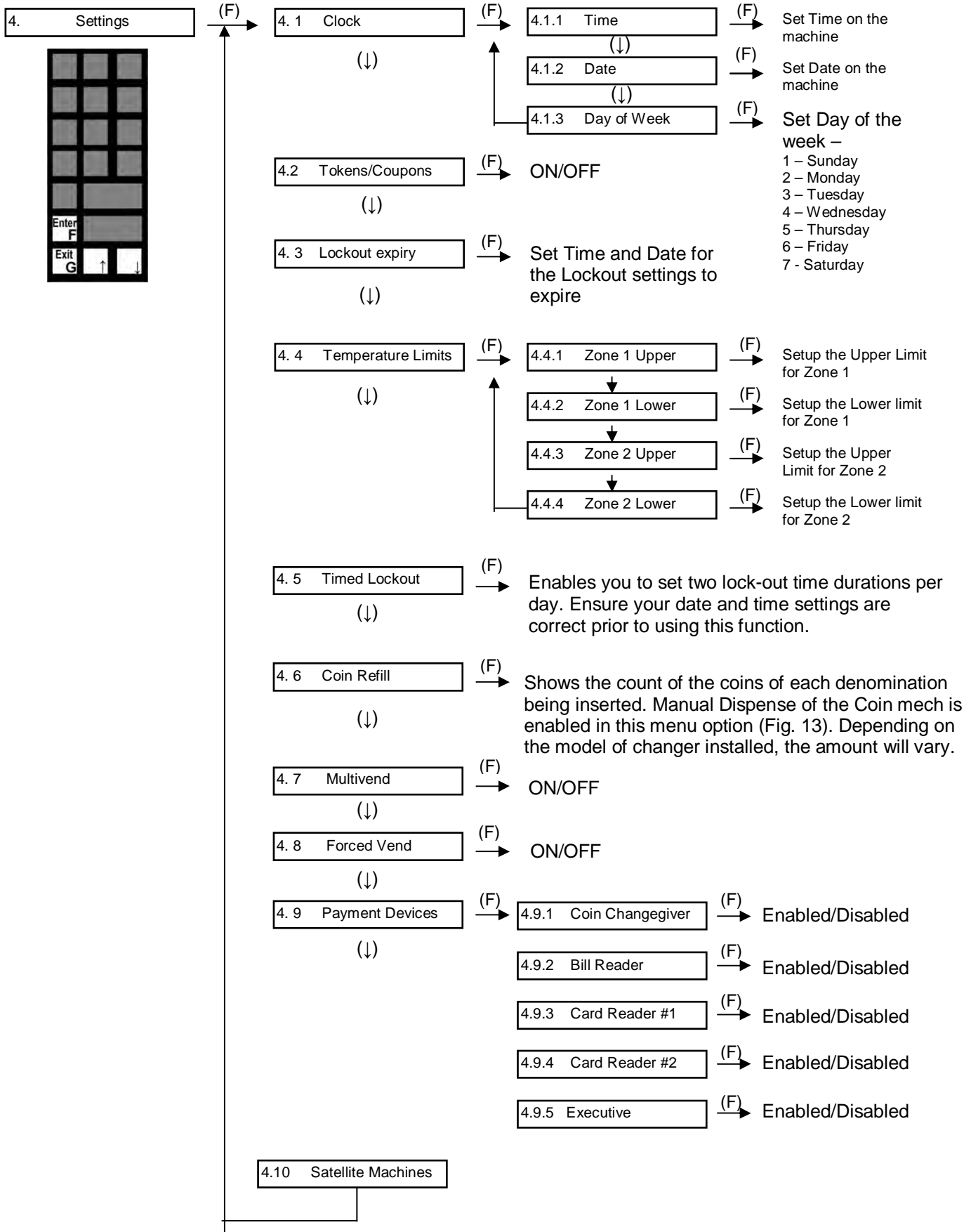


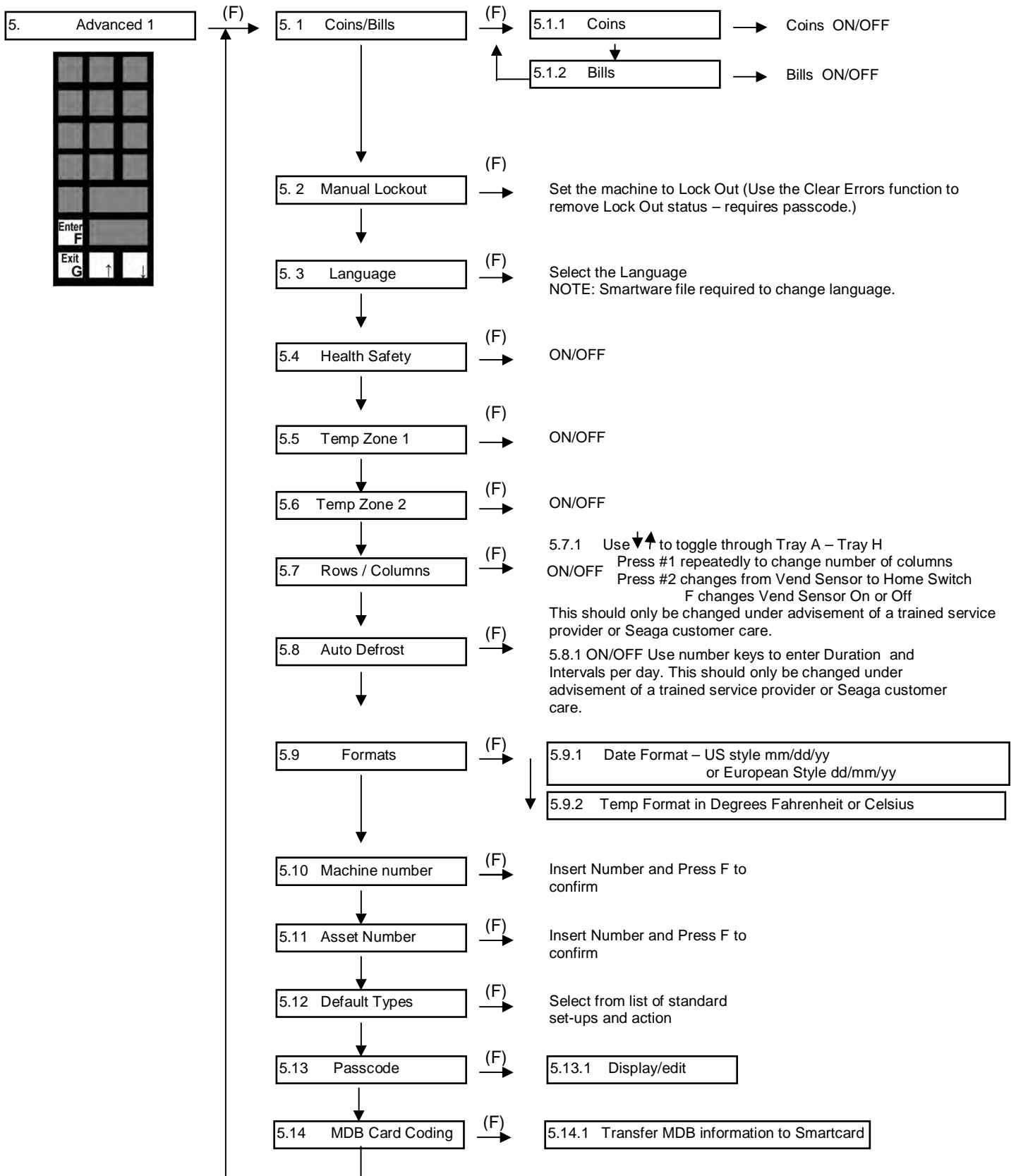
Fig. 13



*Total Value Dispensed and Total Value Inserted is a cumulative total for each coin.

ADVANCED SUB-MENU

ADVANCED - This menu is used to setup the Advanced Settings. Please enter the Pass Code in order to access this menu.



EXIT SERVICE MODE

To Exit the Service Mode or any of the menus, press "G".

SECTION 4**SMARTWARE V2.2.5**

The Seaga Smartware setup utility enables Setup smart cards to be used to set the configuration of the new generation of Seaga vending machine controller boards. The utility works in conjunction with a USB smart card reader.

- **System Requirements**

- Seaga Smartware CD
- Approved USB Card Reader
- Seaga Smart Cards
- PC with the following specification:

	Minimum	Recommended
Processor	Pentium 200MHz Processor	Pentium P4 1000MHz or better
RAM	128M byte	> 256M byte RAM
Free Hard Disc Space	20Mbyte	> 100Mbyte
Graphics	800x600 16 colour SVGA	1024 x 768 256 colour SVGA
Operating System	Windows 98SE	Windows Me, 2000, XP or Vista
CD-ROM	Yes	Yes
USB port	One	More than One

- **Software Installation**

- (i) Installation of Card Reader Drivers

Either :

- Insert the CD into the CD ROM drive
- Select the "Install Card Reader Driver" option

Or (Windows XP / Vista only):

- Insert the CD into the CD ROM drive
- Plugg the card reader into the PC and follow the instructions in the "Add New Hardware" wizard. The Card Reader drivers are located in the **/drivers/** folder on the CD.

Or :

- Run the programme "**setup.exe**" in the "**/2/**" folder on the CD and follow the instructions.

- (ii) Installing the Smartware Application

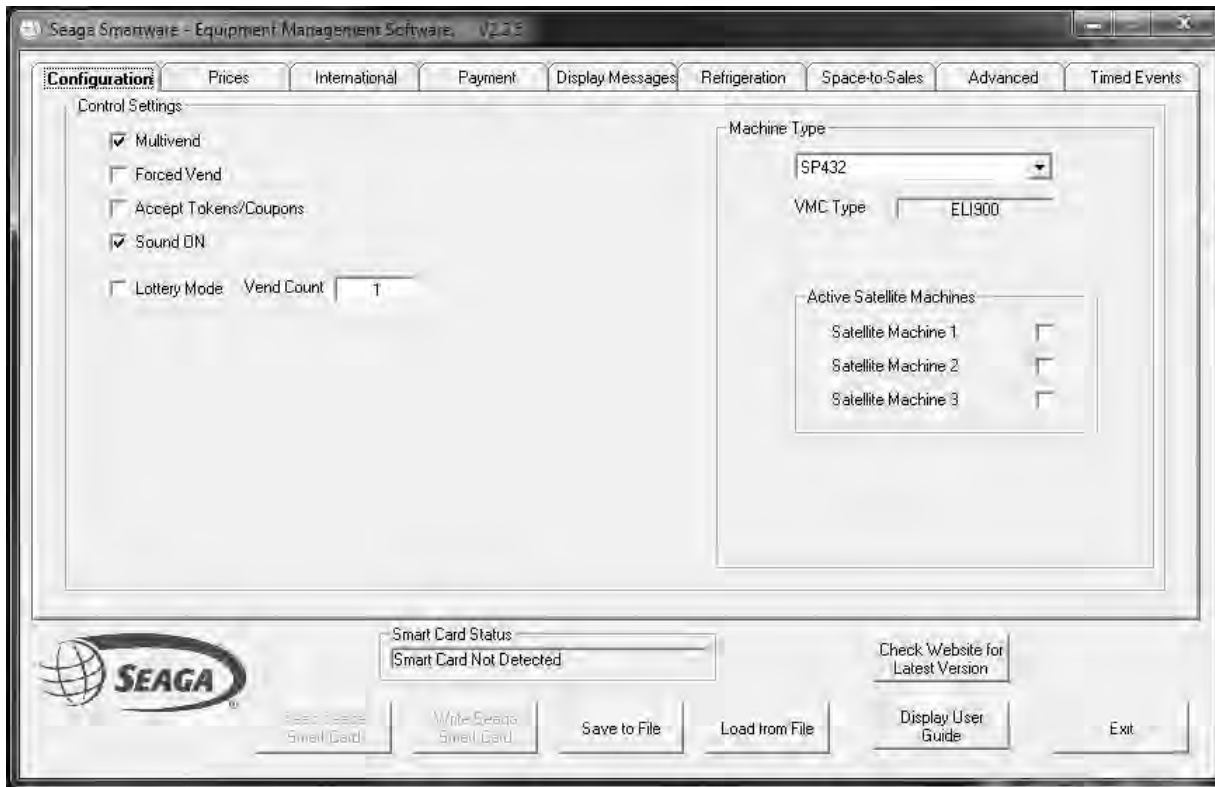
Either:

- Insert the CD into the CD ROM drive
- Select the "Install Seaga Smartware" option

Or:

- Run the program "**setup.exe**" in the top level folder on the CD and follow the instructions

CONFIGURATION PAGE



General Operations

Read Seaga Smart Card – read an existing smart card

Write Seaga Smart Card – programme a card with the current settings

Save to File – save the complete settings to a text file

Load from File – restore previously saved configurations

Check Website for Latest Version – Hyperlink to www.seaga.com/smartware/index.html

Display User Guide

– Hyperlink to www.seaga.com/smartware/Seaga Smartware Guide.pdf

Exit – close the utility programme

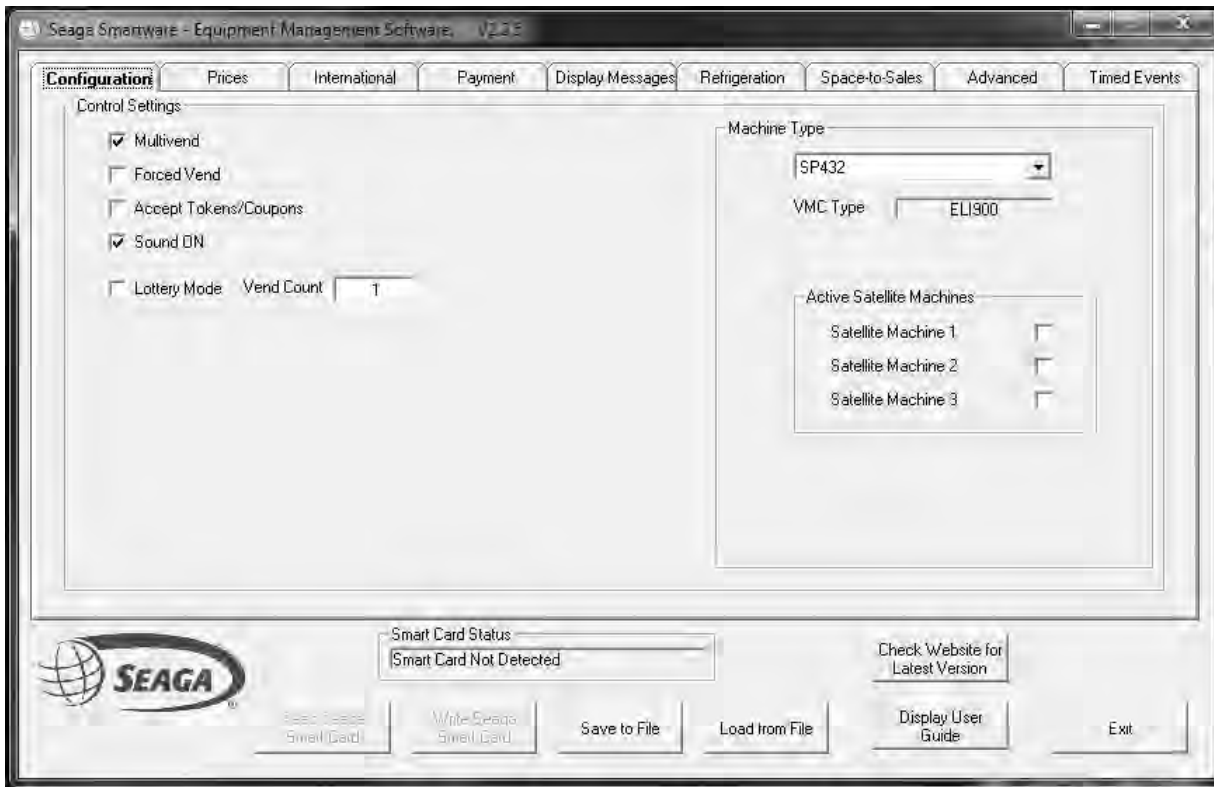
Card Status – shows the status of the card reader

No card inserted	(Read and Write Card buttons disabled)
Seaga 256K smart card	Standard smart card inserted
Seaga 512K smart card	Alternate smart card inserted

Notes

If an Audit or a Temperature Logging Card card type being read the data will be saved to a file once the read is complete. There is a prompt for the file name and an option to clear the card after it has been saved to the file. Refer to Appendix 1 for the file formats.

CONFIGURATION PAGE (continued)



Machine Selection / Basic Settings

Use the **Machine Type** “pull-down” to select a standard machine configuration, or select a specific VMC type.

Multivend, Forced Vend, Accept Tokens/Coupons and **Sound ON** – check the option to enable the corresponding feature.

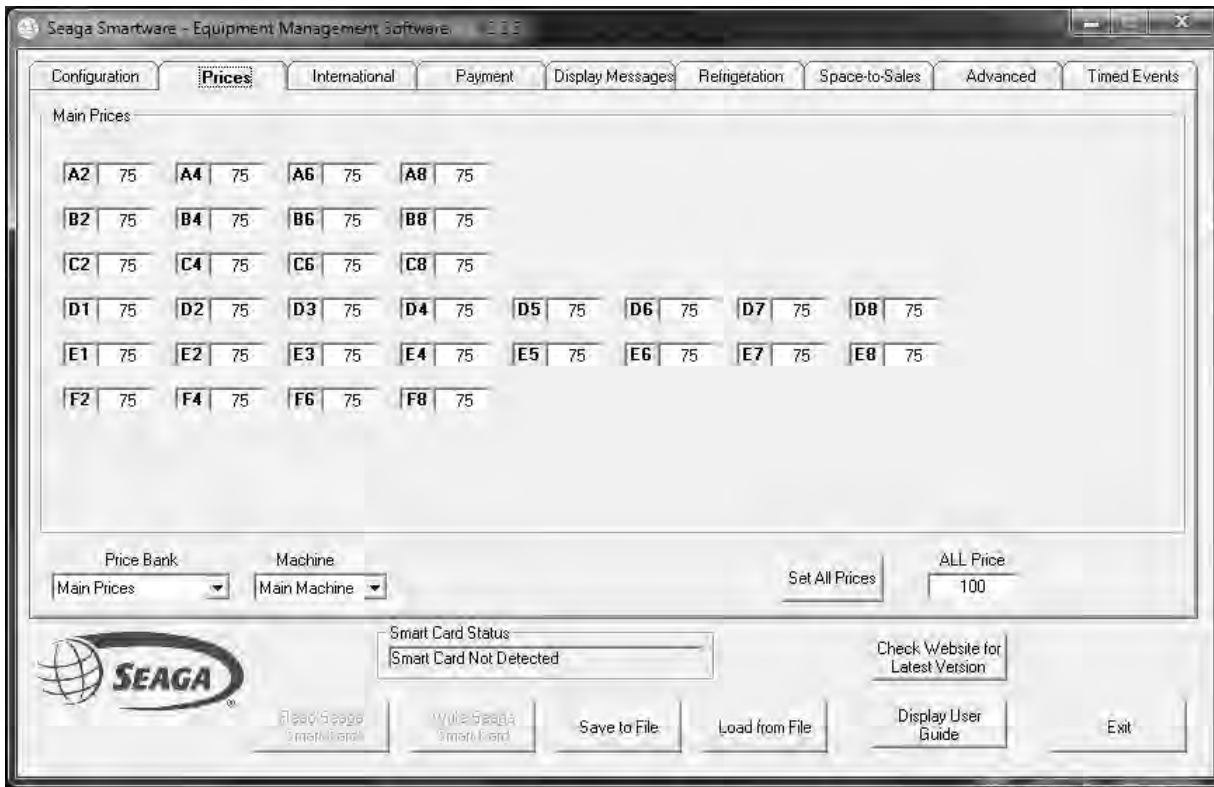
Lottery Mode – check this option and enter a “**Vend Count**” value to allow a free selection, every “**Vend Count**” vends.

Satellite Machine n - check the box to allow the VMC to work with the corresponding Satellite machine.

When a Satellite machine type (VMC type EL906) is selected there is an option to configure the machine as **Satellite 1, Satellite 2** or **Satellite 3**.

Note : some features described in this guide are not available on all VMC configurations. If a particular item is “greyed out” or not shown, it is not available for the current machine.

PRICES PAGE



Depending on the machine configuration, up to 80 Price Boxes will be displayed for the machine.

To set a particular **price** type the value, in cents/pence, into the corresponding **price box**.

To set **ALL** the prices to the same amount, enter the amount in the **ALL Price** box and click the **Set All Prices** button.

The VMC can hold prices for the Main Machine and also up to three Satellite (MDB USD) machines – prices for the satellite machines can be accessed using the **Machine** “pull down” menu.

Individual selections may be named – refer to the **Text Messages** page for more details

PRICES PAGE (continued)



Discount Prices

Select **Discount Prices** using the **Price Bank** pull-down.

The VMC can operate at discounted prices between the **Discount Start Time** and **Discount End Time** points - refer to the “Timed Events” section.

PRICES PAGE (continued)



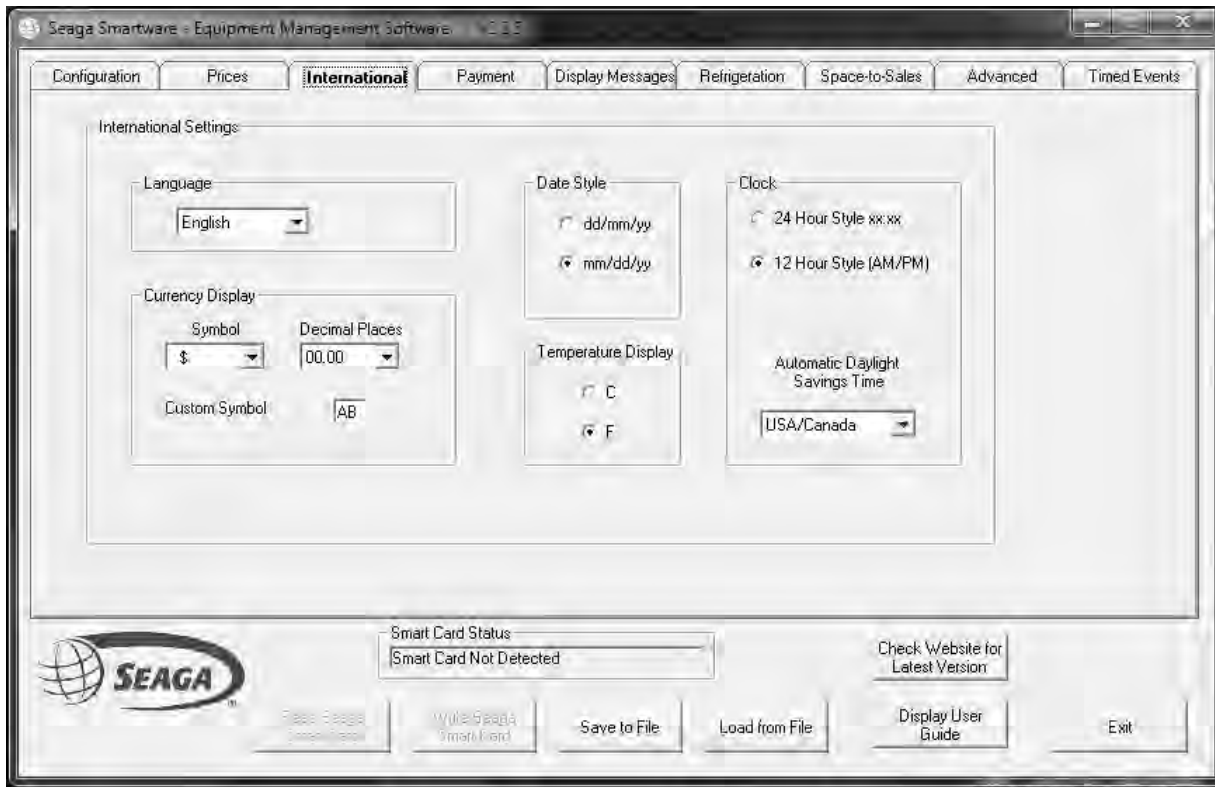
Meal Deals

These are multiple selections that may be offered at a discount price for the group of selections.

Meal deals are selected using the special selection prefix “GG” followed by the 1 – 10 key. The Meal Deal price is charged to the customer and multiple products are vended as specified.

Each of the 10 meal deals can have an individual price, followed by a list of selections that make up the deal. Each deal can comprise up to 4 selections which may be from the Main machine, or from Satellite machines. In the example above meal deal GG2 comprised selection D1 from the main machine plus selection A10 from the second satellite machine.

INTERNATIONAL PAGE



Language

Select the default language for the display using the pull-down list. One language option is **EEPROM**. This language bank may be edited for special configurations and non-supported languages. Refer to the **Text Messages** page for more details.

Currency Display

Choose the desired currency **Symbol** and the number of **Decimal Places** to be displayed. If the required currency symbol is not in the options, choose **Custom** and type in two characters in the **Custom Symbol** box.

Date Style

Choose between **mm/dd/yy** and **dd/mm/yy** styles

Temperature

Choose between displaying Centigrade and Fahrenheit. **IMPORTANT**: Check the values on the **Refrigeration Page** AFTER changing the Temperature scale.

Clock

Choose between 24 hour and 12 hour modes to be displayed.

Select the **Daylight Saving Time** option for automatic summer/winter changes in the **USA** and the **UK/Europe** if required.

NOTE: When using custom display message, Language must be set to "Alternate Language 2".

PAYMENT PAGE



Payment Devices

Check the corresponding boxes to turn Card, Coin and Bill payment on

Executive – check this box to operate with an Executive / Protocol-A coin change giver.

Coin Change giver

Check the **Enabled** box to allow the corresponding coin to be accepted normally, and the **Enabled in Exact Change** box to allow this coin to still be accepted when the machine is in Exact Change mode.

Check the **Manual Dispense ON** box to allow tubes to be emptied manually.

Bill Reader

Check the **Enabled** box to allow the corresponding Bill to be accepted. Check the **Use Escrow** box to hold the Bill for change and the **High Security** box to use the corresponding bill acceptance security level.

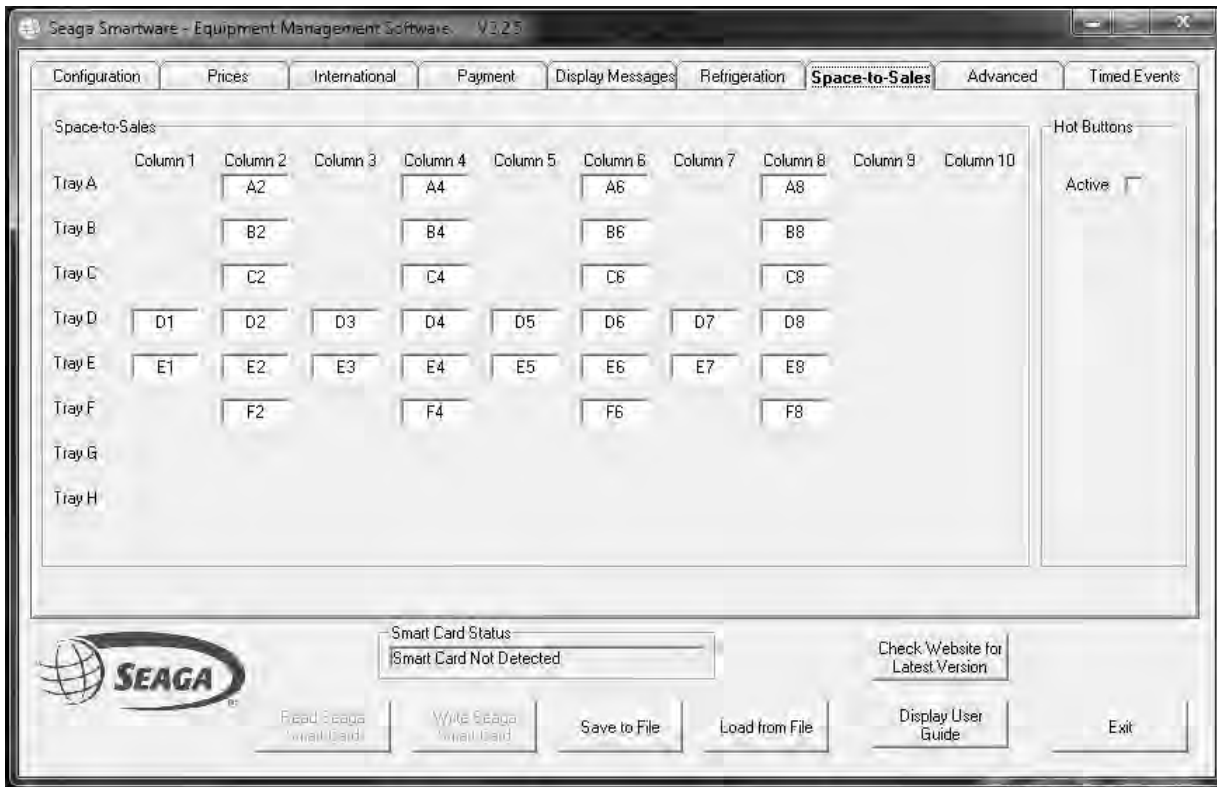
Exact Change Algorithm

The VMC applies two criteria for creating the **Exact Change** condition. **Exact Change** is set when ANY tube has less coins in the tube than the **Minimum Coins In Tube** quantity OR if the total value of the coins in the tubes is less than the highest price set multiplied by the **Minimum Value in Tube** multiplier.

Special Features

Card Reader can Change Price – check this box to allow the card reader device to apply discounts.

SPACE to SALES PAGE



Stock Links

Where more than one selection contains the same product it is possible to link these selections together so that if one selection is sold out the product can be dispensed from another selection. This is particularly useful for increasing the effective stock for Meal Deals, and for Can/Bottles operation.

In the example above selections D1, D2 and D3 have the same type of product and have been linked together in a chain. All other selections are not linked and refer back to themselves.

HOT BUTTONS (Space to Sales Page)



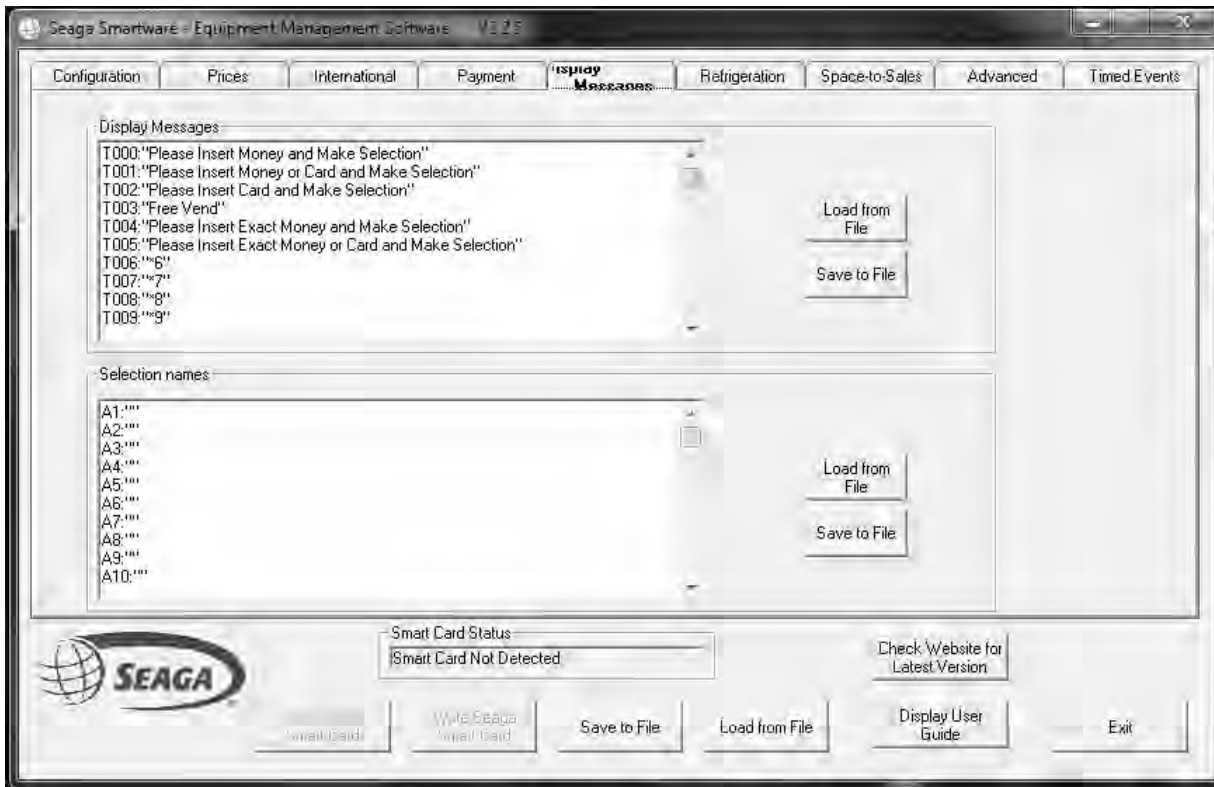
Hot Buttons

Check the “Active Button” to use Hot Buttons.

Hot Buttons replace the standard keypad selections with up to 5 direct, single button selections. For capacity the Space To sales links allow multiple internal spirals to stock the same product.

In the above example Hot Button 1 selects effectively Tray A. The hot button is linked to Selection A2 which in turn is linked in a chain to the other selections in Tray A. Similarly hot buttons 2 – 5 access trays B to E respectively.

DISPLAY MESSAGES PAGE



VMC Text Messages

This window displays the text held in EEPROM for an alternate language set. To Edit the **VMC Text Messages** use the **Save to File** button to save the text to a particular file . This file can be edited using **Notepad** and then reloaded using the **Load from File** button.

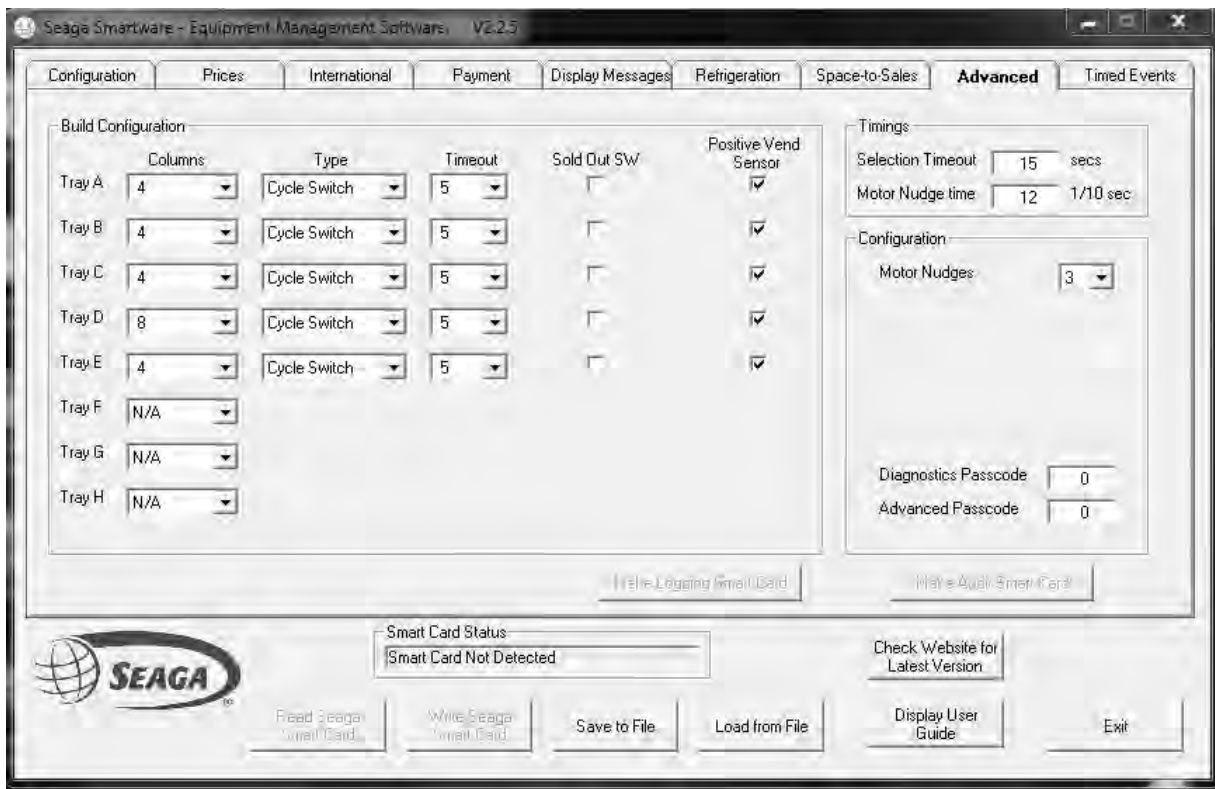
Selection Names

This window displays the text that is displayed for each **Selection** or **Meal Deal**. To Edit the **Selection Names** use the **Save to File** button to save the text to a particular file . This file can be edited using **Notepad** and then reloaded using the **Load from File** button.

When either of the “Save to File” options are selected Windows Notepad is launched directly to allow easy editing.
IMPORTANT: When editing is complete save the changes from within Notepad and then use the **Load from File** button to install the changes.

NOTE: When using custom display message, Language must be set to “Alternate Language 2”.

ADVANCED PAGE



Build Configuration

This section allows the tray options to be defined for the particular machine. Select the number of **columns** for a particular tray, the Motor **Type** as below, the overall run **Timeout** in seconds for the motor and whether a **Sold Out switch** is fitted.

Motor Types :

- Cycle Switch - stops when the Home Switch is reached
- PV Sensor - stops when a product triggers the "Positive Vend Sensor"
- Timed - runs for a fixed period of time

Positive Vend Sensor

- check this box if one is fitted and to be used for the corresponding tray. (Please note that some older VMC software versions may not support individual use of the Positive Vend Sensor)

Timings

Selection Timeout is the number of seconds for which a selection is deemed made, and for which the **product name** and **price** are displayed.

Motor Nudge Time is the amount of time the motor is run after it has "homed" when **the Positive Vend Sensor** has not been triggered

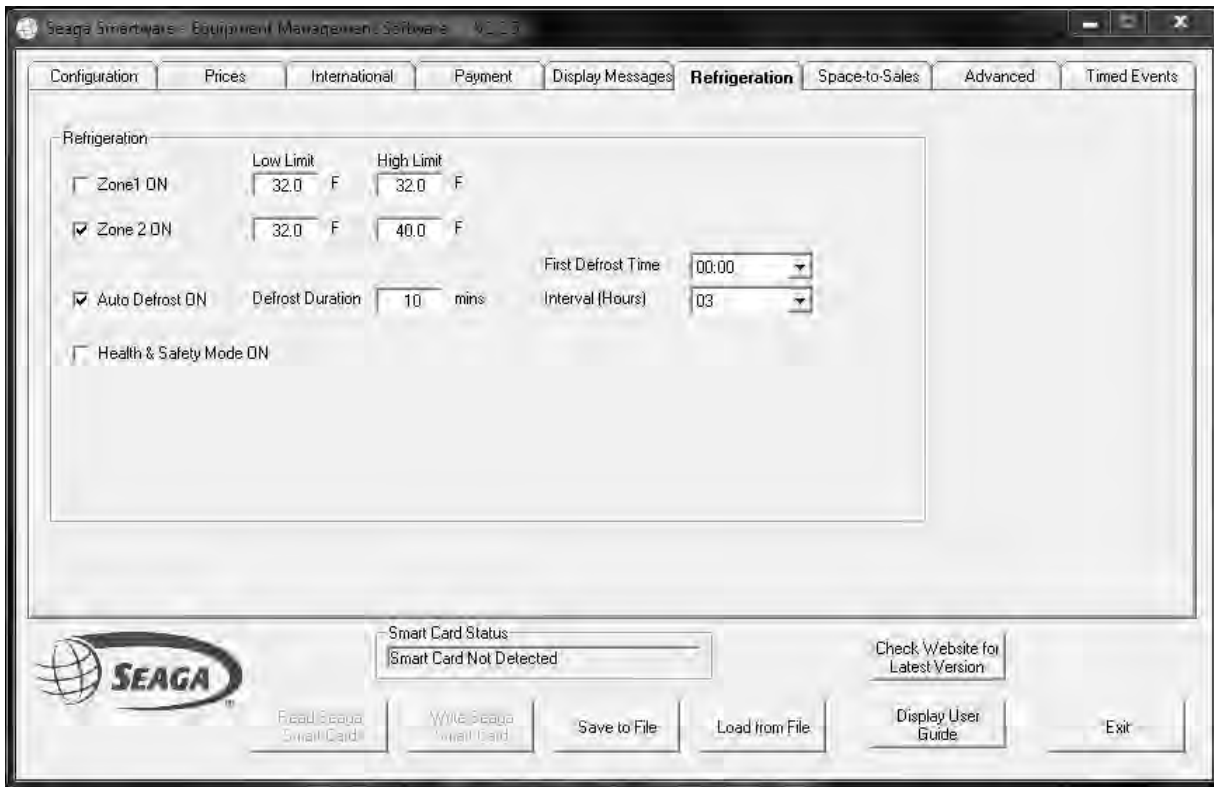
Configuration

- Motor Nudges** - define the maximum number of nudges (up to 6) to be used
- Diagnostics Passcode** - a 4 digit code for access to additional diagnostic features in the menus.
- Advanced Passcode** - a 4 digit code for access to the Advanced menu features.

Make Logging Smart Card / Make Audit Smart Card

- create a blank smart card of the selected type.

REFRIGERATION PAGE



Zone n ON – check the appropriate boxes turn refrigeration control ON for the Zone

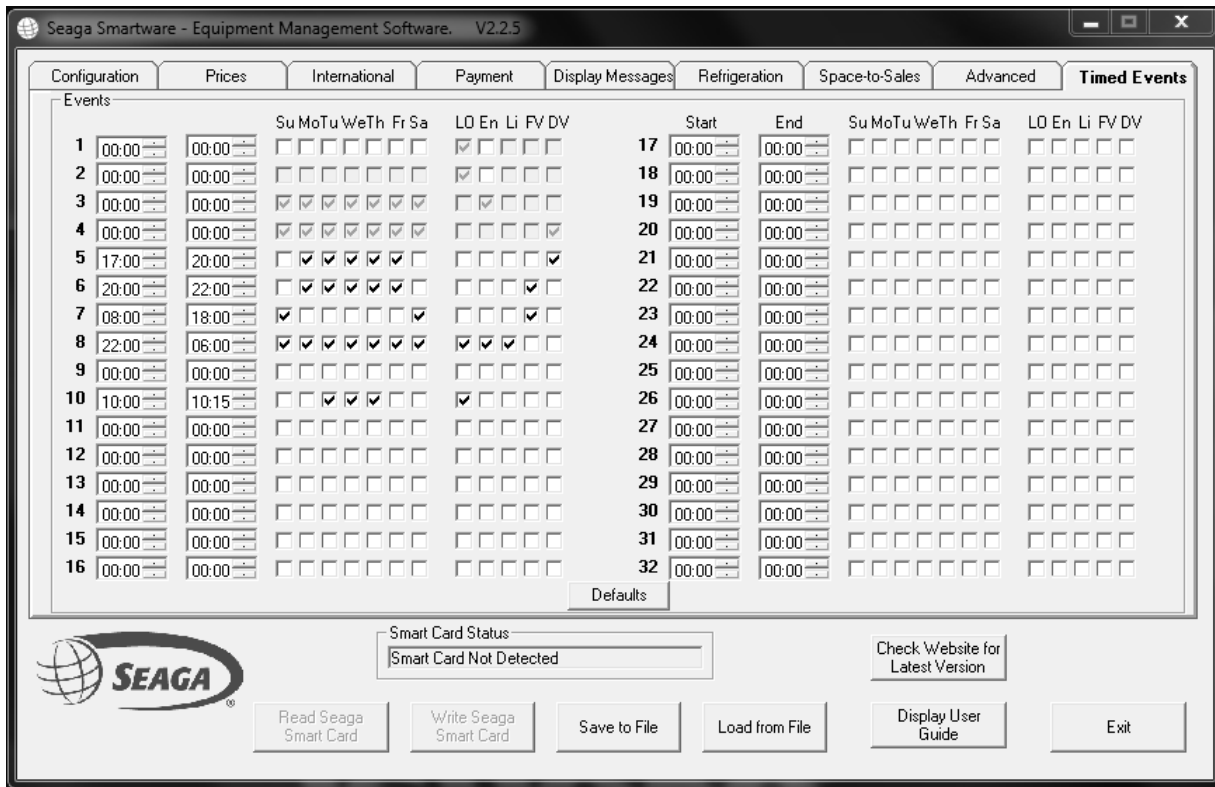
Low Limit / High Limit Temperatures – set the upper and lower temperature limits for the zone. Note: the VMC internally works in 0.5C steps so exact Fahrenheit figures may be adjusted to the nearest 0.5C step.

Auto Defrost

Check the box to turn automatic defrosting ON. The defrost cycle is run for **Defrost Duration** minutes every **Interval** hours. The **First Defrost** after turning the feature ON may be set with the pull-down option. Thereafter the **Interval** value defines when the next defrost will occur.

Health & Safety Mode ON – check the box to turn this lockout mode ON.

TIMED EVENTS PAGE



Version 1.10 and later Premier VMC software supports up to 32 separate timed events. Each event can be set to occur between the **START** and **END** times for the selected **days of the week**. Event times may overlap.

Each Event can then have the following actions (more than one selection may be applied)

- LO** Timed Lockout
- En** Refrigeration Energy Saving Mode
- Li** Lights OFF
- FV** Free Vend
- DV** Discounted Vend (If both **DV** and **FV** are selected, free vend will apply)

Use the **Defaults** button to clear the events back to the factory default configuration

Events 1 – 4 are backwards compatible with earlier versions of VMC software.

- Events 1 and 2** Timed Lockouts with shared **Days of the Week** active.
- Event 3** Energy Saving only
- Event 4** Discounted Vend only

In the screenshot above the following events are set for an example “factory/office” application:

- Discounted prices for anyone working late 17:00 to 20:00 on weekdays
- Free vend for anyone working after 20:00 on weekdays and between 08:00 and 18:00 at weekends.
- Energy saving every night from 22:00 until 06:00 the next morning, which means that In Energy saving Mode, the compressor will shut off at 40 °F and turn on when the temperature reaches 43° F. (During normal operation the temperature range is held from 37 °F to 43 °F.
- Timed Lockout between 10:00 and 10:15 on Tuesdays, Wednesdays and Thursdays for a “staff meeting”

Appendix 1 – File formats

Both Audit and Temperature Logging Cards are saved to .csv (comma separated value) format files that can be imported into a number of packages, including Microsoft Excel. Records are tabulated with a title to each column.

Example Audit File – values are in base units (cents, pence etc.)

	A	B	C	D	E	F	G	H	I	J	K
1	Date	Time	Machine No	Asset No	Coin	Note	Card	Change	M-Disp	Sales Value	Free Vend Tokens
2	18/04/2007	21:08	134	12345	7250	0	0	2425	0	4400	0
3	18/04/2007	21:09	134	12345	7350	0	0	2475	0	4450	0
4											
5											
6											

Example Temperature Logging File – in this example, temperatures are in Centigrade, defrost duration is in minutes. Readings are logged approximately every minute.

	A	B	C	D	E	F
1	Date	Time	Zone 1	Zone 2	Defrost	
2						
3	18/04/2007	23:55	24.5	26.5		
4			-18.5	-4		
5			4.5	12.5		
6			12	19		
7			16	21.5		
8	19/04/2007	00:00			10	
9			19.5	23.5		
10			21	24.5		
11			22	25.5		
12			22.5	26		
13			23	26		
14			23.5	26.5		
15			23.5	26.5		
16			23.5	26.5		
17			23.5	26		
18			23.5	26		
19			24	26.5		
20			23.5	26.5		
21			24	27		
22			24	27		
23			24	27.5		
24			24.5	27.5		
25			24.5	28		

SECTION 5

DELIVERY OF PRODUCT

DELIVERY SYSTEM

Your vendor consists of the Keypad, 2 Line VF Display, Driver Motors, Product Trays, Helix Coils and Delivery Bin. The customer inserts money and enters their selection on the Keypad. The selection's Driver Motor turns the Helix Coil that vends the product into the Delivery Bin.

PRODUCT TRAYS

Your vending machine features lock and release product trays. On the right side of each product tray you will find a Locking Lever (Fig. 14). To pull out the Product Tray push down on the Locking Lever and roll toward you to tilt position. Or completely push the locking lever to the back.

Fig. 14



PRICE SCROLLS AND SELECTION LABELS

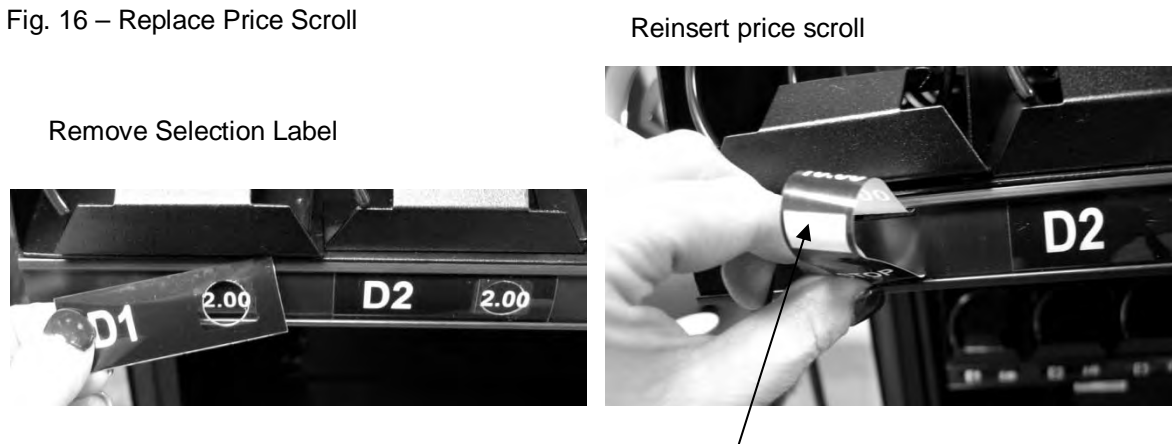
Price scrolls showing denominations from .50 to 6.00 are fitted to each tray position. To adjust the pricing display, use your thumb or finger to rotate the scroll to show the desired price (Fig. 15). Note: this does not change the price of the item but only the display. The actual price must be changed via the service mode menus detailed in Section 3 of this manual.

Fig. 15 – Adjustment of Price Display



Note that the word "STOP" showing in the price display is an indication that you should stop rotating the scroll as the end has been reached. Should the scroll end become disengaged from the tray, simply remove the Selection Label and reinsert the scroll end. Rotate the scroll to the proper position and replace the Selection Label.

Fig. 16 – Replace Price Scroll



Blank white squares are available on the price scrolls just before the STOP indicator for custom pricing.

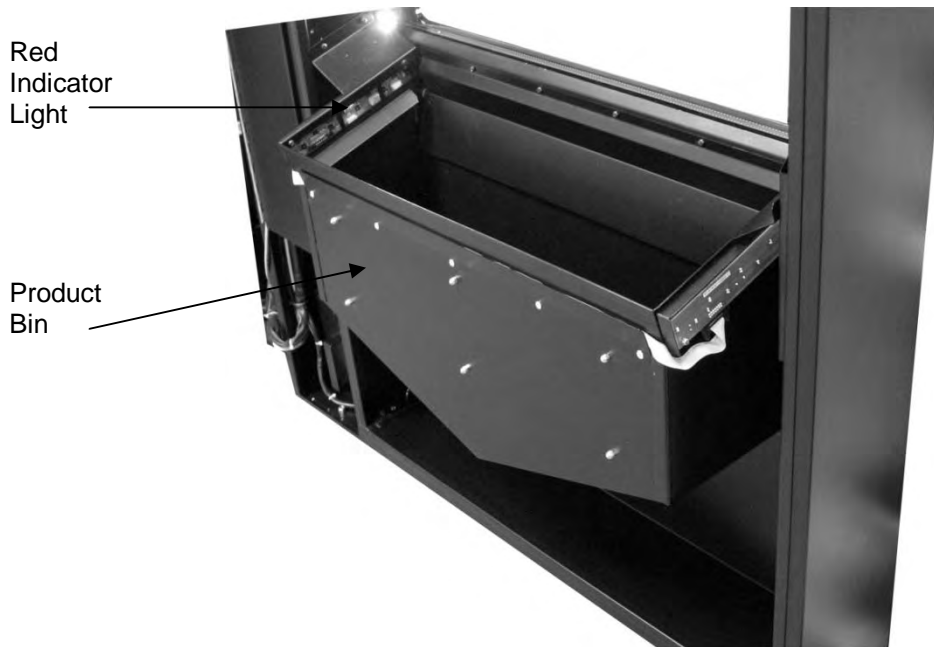
VIGILANT VEND SENSOR SYSTEM

The Vigilant vend sensor system is a series of infrared sensors that send a beam of light across the delivery bin. If this beam is broken by a product, the machine knows that an item was delivered to the customer. If this beam is not broken, the machine assumes that nothing was vended and turns the selection spirals by ¼ turns up to 3 times. If no product is delivered, the customer will receive their money back.

Certain products can be problematic for any vend sensing system. Products that are very thin or very small in size may, on occasion, miss the beams. With proper loading of the machine, sensing systems are irrelevant. A comfort level is provided to customers who walk up to the machine and know, through technology, they will not experience a “rip-off”. For this reason, a vend sensor system is desirable – however, if you vend very small or very thin items, you may want to consider turning off your sensing system in case of malfunction via product size. See the Service Mode section of this manual, Advanced menu, Rows and Columns sub-menu, for instructions.

The Vigilant vend sensors, made up of the emitter (right) and detector (left) are located inside the delivery bin as shown in Figure 17. There is a red indicator light located on the left side when viewing the bin from the inside with the door open. This light should be lit when the system is on, indicating that there is power to the system. Blocking any of the beams turns off the red indicator light, which means the system is working correctly.

Fig. 17 Vend Sensor System



Note: When performing Motor Tests without product loaded, it is a good idea to shut off the Vigilant system.

ERROR CODES

Motor Diagnostic Errors:

- 01 - Motor did not Home
- 02 - Reserved
- 03 - Motor is Stuck at Home
- 04 - Reserved
- 05 - Low Current (Motor did not move)
- 06 - Over Current (Hard Error)**
- 07 - Motor not detected**

Machine Error Codes:

- 01 – 80 - Motor fault from Selection A1 to Selection H10
- 100 - Coin Changer not connected
- 110 - Bill Validator not connected
- 120 - Card Reader 1 not connected
- 121 - Card Reader 2 not connected (not used)
- 130 - Audit Device not connected
- 140 - DEX Error
- 150 000 - Satellite 1 not connected (not used)
- 150 001 - Satellite 2 not connected (not used)
- 150 002 - Satellite 3 not connected (not used)
- 160 000 - Overall Credit value is negative
(Negative credit giving a large credit amount that can be dispensed as change)
- 160 001 - Coin Credit was negative
- 160 002 - Bill Credit was negative
- 160 003 - Bill Return MDB message (value of Bills in escrow exceeds the Bill credit)
- 160 004 - Price - Credit when starting a vend
- 160 005 - Amount returned when Cancelling/Returning credit in Multivend exceeded credit
- 160 006 - Out Of Change when Cancelling/Returning credit in Multivend
- 160 007 - Change value is negative after stacking bill
- 160 008 - Amount returned as change in single vend mode exceeded credit
- 160 009 - Out of Change when giving change in single vend mode
- 170 001 - Temperature Sensor Error Zone 1 (not used)
- 170 002 - Temperature Sensor Error Zone 2
- 201 - Periodic Lockout
- 202 - Health & Safety Lockout

See the Diagnostics Menu information in this manual for more on viewing the error log and clearing errors.

1.

NO DISPLAY ON THE FRONT PANEL

- a. Harness may be unplugged
- b. Faulty display harness
- c. Transformer fuse blown
- d. Display board defective
- e. Restart machine

2.

SELECTION WILL NOT VEND

- a. Disconnected tray wire harness
- b. Detection system may be blocked, if enabled
- c. Vend mechanism binding on tray
- d. Product jammed
- e. Tray or Motor connection unplugged or faulty connection
- f. Defective motor

3.

MULTIPLE VENDS FROM ONE SELECTION

- a. Detection system malfunction, if enabled
- b. Defective motor switch
- c. Detection system may be blocked, if enabled

4.

MULTIPLE VENDS MORE THAN ONE SELECTION SIMULTANEOUSLY

- a. Defective motor
- b. Motor harness not plugged into the vend motor correctly
- c. Defective or damaged motor interface board [KS11]
- d. Tray cable faulty

5.

UNIT WILL NOT ACCEPT MONEY

- a. All Prices are set to zero or machine is set to Free Vend
- b. Will not accept bill if coins in coin changer below the minimum level
- c. Will not accept more than one bill if the bill equal or exceeds the highest priced item.
- d. No power to system control board
- e. Coin Mechanism or Bill acceptor defective.

Q: I rearranged my trays and now some selections don't work. Display says Make Alternate Selection.

A: Enter the service mode. Press the 10 button 4 times. Display should show Passcode Accepted. Scroll to Advanced sub menu and press F to enter. Scroll to Rows / columns setting and press F to enter. Display will show setting for each tray position. The 1 button will cycle through the different tray configurations. It will cycle from 0 (tray off) then to 4, 5, 7, 8, 10 then back to 0. Set this to the number of selections on that tray. When finished with the settings for that tray use the arrow keys to scroll to the next one to set. If you are finished press the G key multiple times to exit. This only applies to machines with software revision .65 and higher. Earlier versions will require a software update. Contact your distributor or sales person for update information.

Q: My machine will not take in bills but accepts change ok.

A: Several options here but the most common especially when first setting up the machine is that there is not enough change in the changer. By looking at the display it will give you a clue as to what may be wrong. If the display reads "Please Insert Exact Money...." that indicates there is not enough change in the changer. Fill the coin tubes completely full. Completely full means you can't get any more change into the coin tube. Press the coin return button and the display should show Canceling. The display should now show "Please Insert Money....." without the word Exact.

Q: My machine still will not accept bills and the display does not indicate Exact change.

A: If the validator takes in the bill partially but ejects it back out, that indicates that the bill may be unacceptable or the validator needs cleaning. Check for a jammed bill behind the bill box. Follow the validator manufacturer's recommendation for cleaning.

Q: My machine will accept \$1 bills but not \$5 bills.

A: This situation can depend on several factors. Make sure the bill validator is set to accept \$5 bills. The amount of change being reported in the changer must accommodate the highest vending price in the machine, so make sure the changer is full of change. If you are vending high priced items you may need to replace the changer with a larger capacity model.

Q: My machine will not accept the new \$5 bills.

A: Contact the bill validator manufacturer for upgrade instructions. Not accepting currency that has been changed due to a Federal Government mandate is not covered under our manufacturer's warranty.

Q: My machine will vend a product, display Vend Error then give my money back or allow me take make an alternate selection.

A: This indicates there is a problem detected with the vend motor. Each vend motor has a small micro switch inside that indicates when the motor has made one full revolution and returns back to what is referred to as the "home position". If this signal is not received back to the controller in a specified amount of time the controller will indicate an error and refund the money. The problem could be in an individual motor itself, the tray wire harness or any connection in between the tray to the control board. If the whole tray acts this way that usually indicates that the tray harness or any connection in between to the controller may be bad. The easiest way to troubleshoot this situation would be to swap tray connections where the tray harness plug plugs into the machine. For example if the problem appears on the A tray, unplug the A tray and the B tray (assuming they both have the same number of selections), swap the connections and plug the A tray into the B tray receptacle and vice versa. Now do your test vending by selecting the B selections on the keypad and the A tray should operate. If the problem follows the tray then suspect either the motor or the tray cable harness. If the problem stays with the A receptacle and now the B tray exhibits the problem then the problem is in a connection somewhere between the A receptacle and the controller board. Make sure to examine any and all connections for any loose wires, etc.

Q: My display is dead or intermittent but the rest of the machine appears to be working.

A: Check the gray flat ribbon cable connection between the display and the controller board to insure the plugs are plugged in securely.

Q: My machine will not cool.

A:

1. Make sure the machine programming is set up properly so that Zone 2 is enabled and the proper temperature limits are set for Zone 2. Zone 2 lower should be set around 37 degrees and Zone 2 upper should be around 5-6 degrees warmer. If the temperature is set too cold then you risk the chance of evaporator freeze over.
2. On models equipped with a refrigeration fuse make sure it is not blown. The fuse needs to be a 20 amp Slo-Blo fuse.
3. Inspect the evaporator coil to see if it may be frozen over. Using a flashlight shine it into the 3 evaporator fans located under the bottom tray. You are looking for aluminum fins behind the fan motors. If they are completely white or solid with ice this will keep the air from flowing properly and cause the machine to not cool. To thaw out remove the 3 prong condensing unit plug, not the evaporator fan plug and just close the door and let set

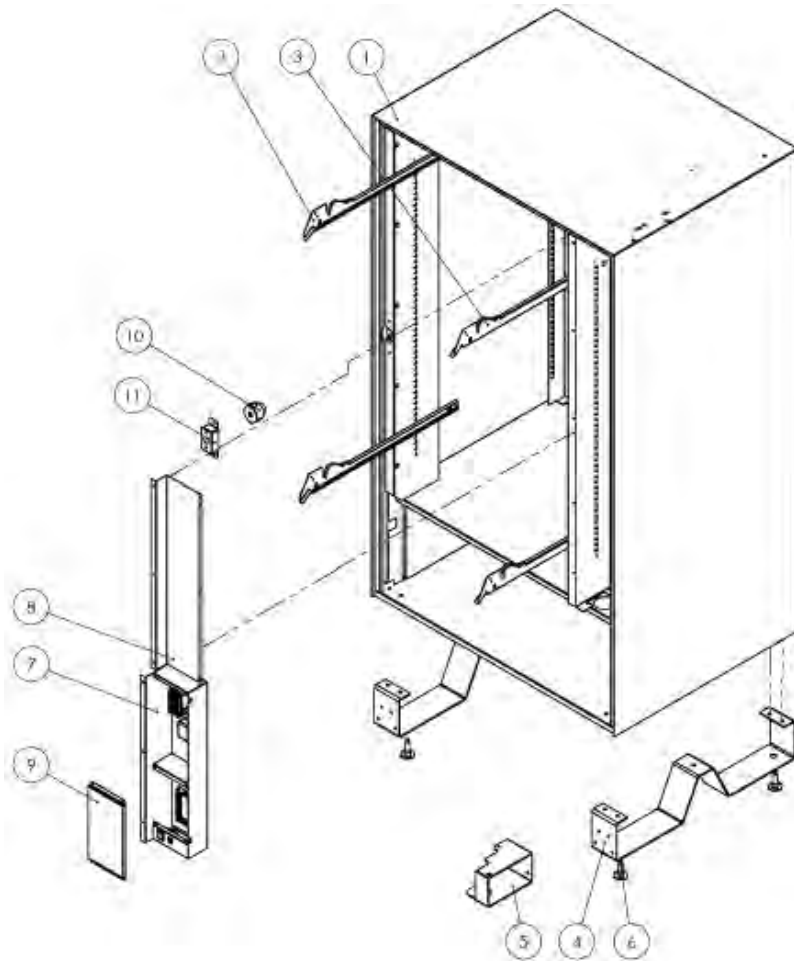
for overnight to insure it completely defrosts. Be prepared in case the defrost water pan overflows on the floor. You may need to set some towels around and under the machine to catch any overflow. After the machine is thawed completely out you will want to check the temperature settings to insure they are not set too cold. You may also enter the Advanced menu and check the defrost settings. The standard defrost settings are for a duration (DUR) of 25 minutes and interval (INT) of 3 hours. This can be changed if need be. Also close the door and listen to hear if the fans start when you close the door. If they don't this will also cause a freeze over. You may need to adjust the door switch to facilitate proper operation.

4. Check the upper door switch. The easiest test is to close the door then while opening the door watch the display to see if you see the message Sales Value \$xxxx.xx in the display. If you do not then suspect the upper door switch may need adjustment. You can reach over the door and press it manually while watching the display to see if it works.
5. As a manual test of the cooling system you can enter the Diagnostics section of the menu and select the Relays test function. Select Relay 02, press F and the cooling system should turn on momentarily.

CAUTIONS:

1. High voltage is located in the area of the unit and could cause injury or death.
2. Replacement of the bill acceptor, coin changer, front panel display, system control board or vend motors should only be performed by trained personnel with power disconnected from the vending machine.

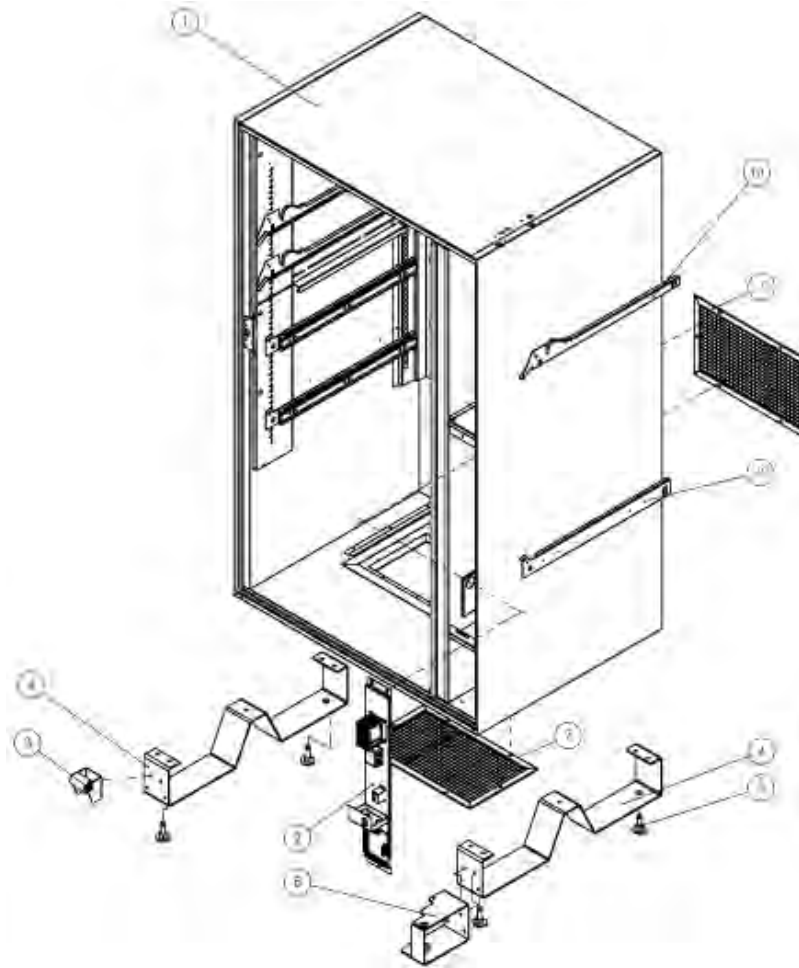
Ambient Cabinet Assembly



Parts List

ITEM	PART NO.	DESCRIPTION
1	SAI88002	CABINET (5-WIDE AMBIENT)
1	SAI70006	CABINET (4-WIDE AMBIENT)
2	STI900	RAIL, TRAY, LEFT
3	STI901	RAIL, TRAY, RIGHT
4	STI573A	LEGS
5	SAI778	SUPPORT, DOOR
6	HAI705	LEVELER, LEG
7	SAI88004	ASSEMBLY, ELECTRICAL BOX
8	STI70039	PANEL, WIRING DIAGRAM
9	STI70034	COVER, TRANSFORMER
10	HAC910	SPLIT NUT, T-HANDLE LOCK
11	STI87038	BRACKET, SPLIT NUT MOUNTING

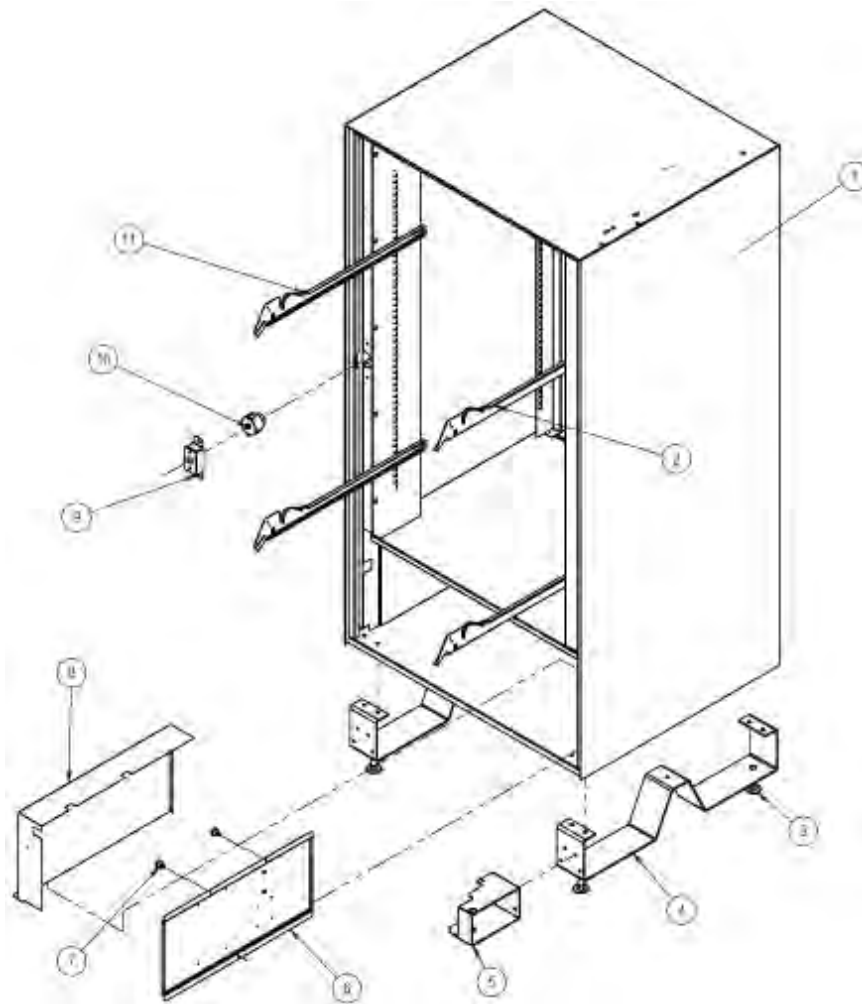
Refrigerated Cabinet Assembly



Parts List

ITEM	PART NO.	DESCRIPTION
1	SAI87001	CABINET, INSULATED (5-WIDE REFRIGERATED)
1	SAI84007	CABINET, INSULATED (4-WIDE REFRIGERATED)
2	SAI793	ASSEMBLY, ELECTRICAL PANEL
3	SAI764A	ASSEMBLY, DOOR SUPPORT ROLLER
4	STI573A	LEGS
5	HAI705	LEVELER, LEG
6	SAI781A	SUPPORT, DOOR
7	STI58022	GRILL
8	STI579	RAIL, BEVERAGE TRAY, LEFT/RIGHT
9	STI900	RAIL, SNACK TRAY, LEFT
10	STI901	RAIL, SNACK TRAY, RIGHT

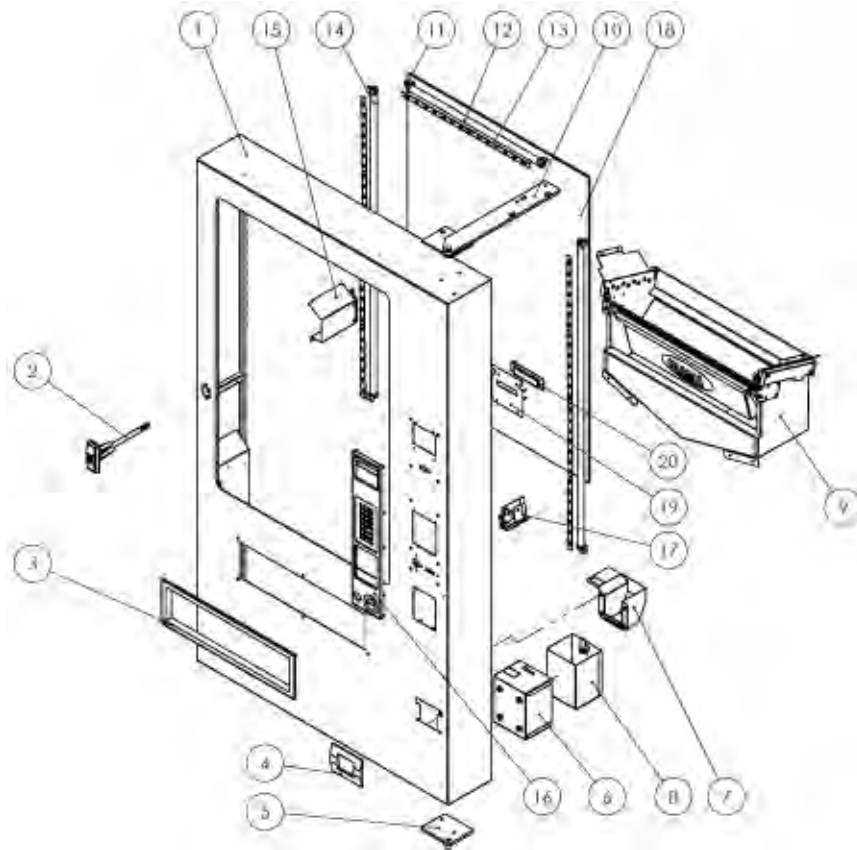
Satellite Cabinet Assembly



Parts List

ITEM	PART NO.	DESCRIPTION
1	SAI89002	ASSEMBLY, MAIN CABINET
2	STI901	RAIL, SNACKS TRAY, RIGHT
3	HAI705	LEVELER, LEG
4	STI573A	LEGS
5	SAI778	SUPPORT, DOOR
6	SAI804	ASSEMBLY, ELECTRICAL PANEL
7	PLI613	KNOB, BLUE
8	STI89007	COVER, ELECTRICAL PANEL
9	STI57038	BRACKET, SPLIT NUT MOUNTING
10	HAC910	SPLIT NUT, T-HANDLE
11	STI900	RAIL, SNACKS TRAY, LEFT

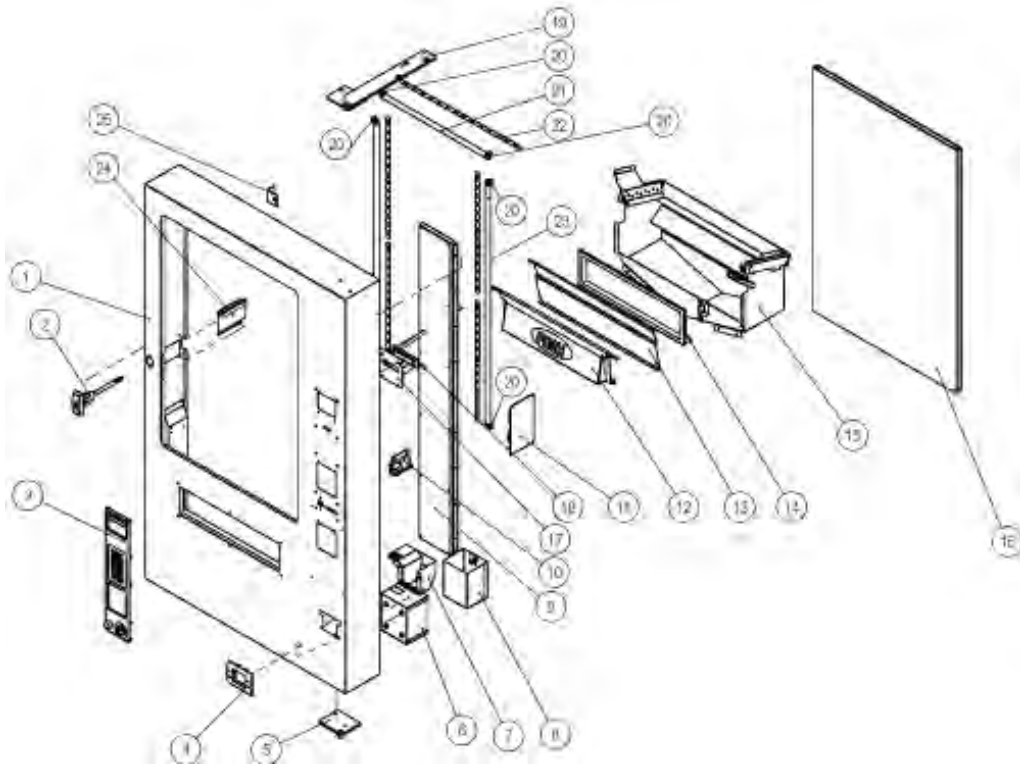
Ambient Door Assembly



Parts List

ITEM	PART NO.	DESCRIPTION
1	SAI88012B	ASSEMBLY, DOOR (5-WIDE AMBIENT)
1	SAI70003A	ASSEMBLY, DOOR (4-WIDE AMBIENT)
2	ELC909	T-HANDLE
3	PLI940	FRAME, DELIVERY DOOR
4	PLI939	BEZEL, COIN RETURN
5	SAI780	ASSEMBLY, HINGE, BOTTOM
6	SAI87033	ASSEMBLY, GUIDE COIN BOX
7	SA87038	TRAY, COIN RETURN
8	SAI87035	ASSEMBLY, COIN BOX
9	SAI809	ASSEMBLY, DELIVERY BIN (5-WIDE AMBIENT)
9	SAI810	ASSEMBLY, DELIVERY BIN (4-WIDE AMBIENT)
10	SAI777	ASSEMBLY, HINGE, TOP
11	PLI2082	CAP, TUBE, LED
12	HAI990A	TUBE, LED
13	ELI962	LED
14	HAI990	TUBE, LED
15	STI87025A	COVER, DOOR LOCK
16	PLI936	BEZEL, KEYPAD
17	SAI773A	ASSEMBLY, COIN RELEASE
18	GLI953A	GLASS (5-WIDE AMBIENT)
18	GLI962	GLASS (4-WIDE AMBIENT)
19	STI70062	PLATE, DISPLAY MOUNTING
20	ELI909	DISPLAY

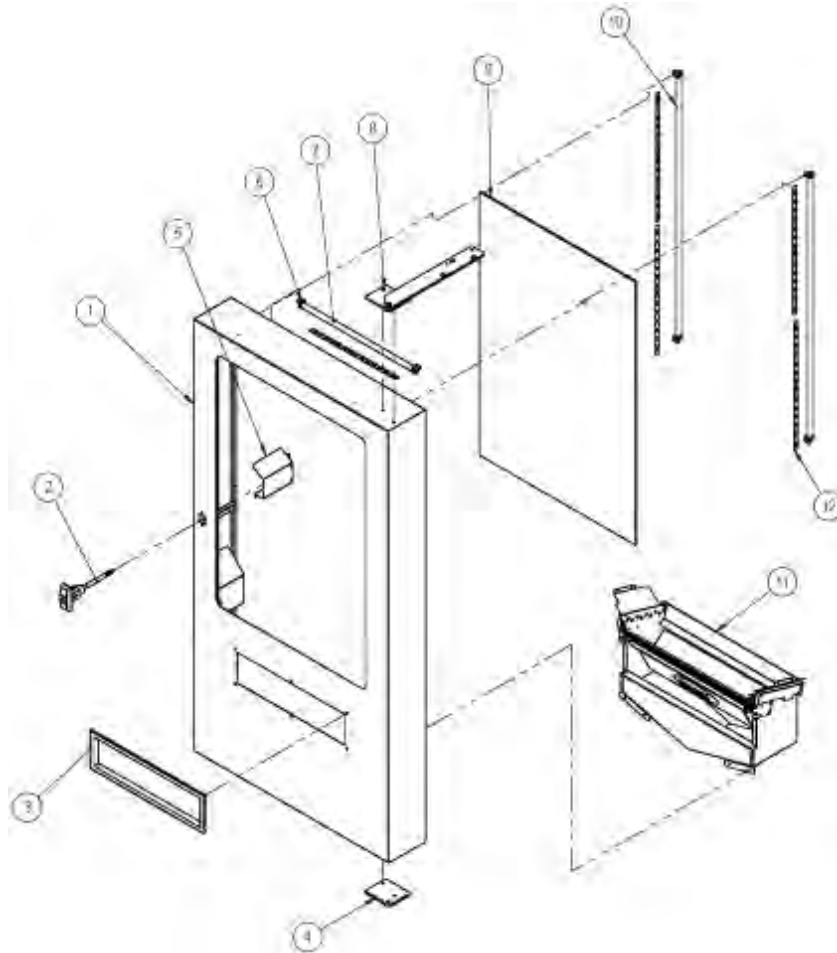
Refrigerated Door Assembly



Parts List

ITEM	PART NO.	DESCRIPTION
1	SAI87009	ASSEMBLY, DOOR, INSULATED (5-WIDE)
1	SAI84009	ASSEMBLY, DOOR, INSULATED (4-WIDE)
2	ELC909	T-HANDLE
3	PLI936	BEZEL, KEYPAD
4	PLI939	BEZEL, COIN RETURN
5	SAI780	ASSEMBLY, HINGE, BOTTOM
6	SAI87033	BRACKET, COIN BOX
7	SAI87038	TRAY, COIN RETURN
8	SAI87035	ASSEMBLY, COIN BOX
9	SAI87031	ASSEMBLY, ELECTRICAL DOOR, REFRIGERATED
10	SAI773A	ASSEMBLY, COIN RELEASE
11	ELI900	VMC
12	PLI943A	DELIVERY DOOR (5-WIDE)
12	PLI943	DELIVERY DOOR (4-WIDE)
13	STI87049	PANEL, ANTI-THEFT (5-WIDE)
13	STI58036	PANEL, ANTI-THEFT, BIN (4-WIDE)
14	PLI940	DELIVERY DOOR
15	SAI785	ASSEMBLY, DELIVERY BIN (5-WIDE REFRIGERATED)
15	SAI360	ASSEMBLY, DELIVERY BIN (4-WIDE REFRIGERATED)
16	GLI954A	GLASS, INSULATED (5-WIDE)
16	GLI952A	GLASS, INSULATED (4-WIDE)
17	STI70061	PLATE, DISPLAY MOUNTING
18	ELI909	DISPLAY
19	SAI777	ASSEMBLY, HINGE, TOP
20	PLI2082	CAP, TUBE, LED
21	HAI990A	TUBE, LED
22	ELI962	LED
23	HAI990	TUBE, LED
24	STI87025A	COVER, DOOR LOCK 5-WIDE
24	STI87025B	COVER, DOOR LOCK 4-WIDE
25	STI70033	BRACKET, DEX SUPPORT

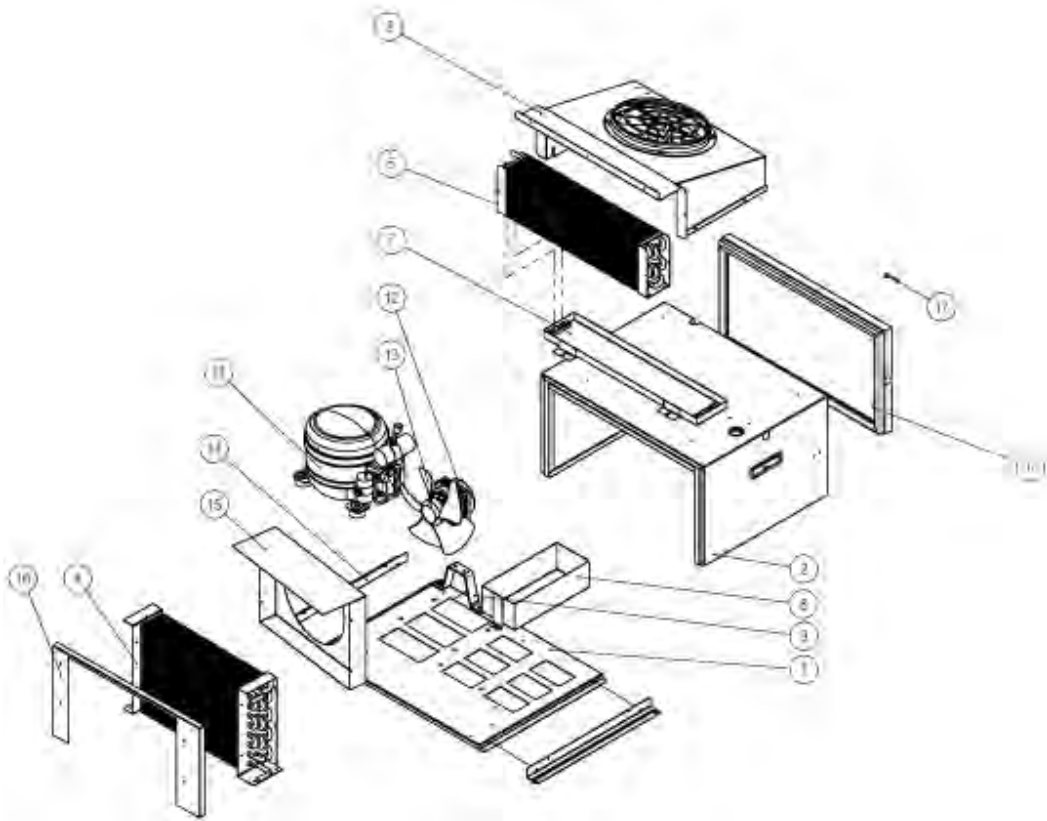
Satellite Door Assembly



Parts List

ITEM	PART NO.	DESCRIPTION
1	SAI89006	ASSEMBLY, DOOR
2	HAC909	T-HANDLE
3	PLI940	FRAME, DELIVERY DOOR
4	SAI780	ASSEMBLY, HINGE, BOTTOM
5	STI70058	COVER, DOOR LOCK
6	PLI2082	CAP, TUBE, LED
7	HAI990A	TUBE, LED
8	SAI777	ASSEMBLY, HINGE, TOP
9	GLI953A	GLASS (5-WIDE AMBIENT)
10	HAI990	TUBE, LED
11	SAI809A	ASSEMBLY, DELIVERY BIN, SATELLITE
12	ELI962C	LED

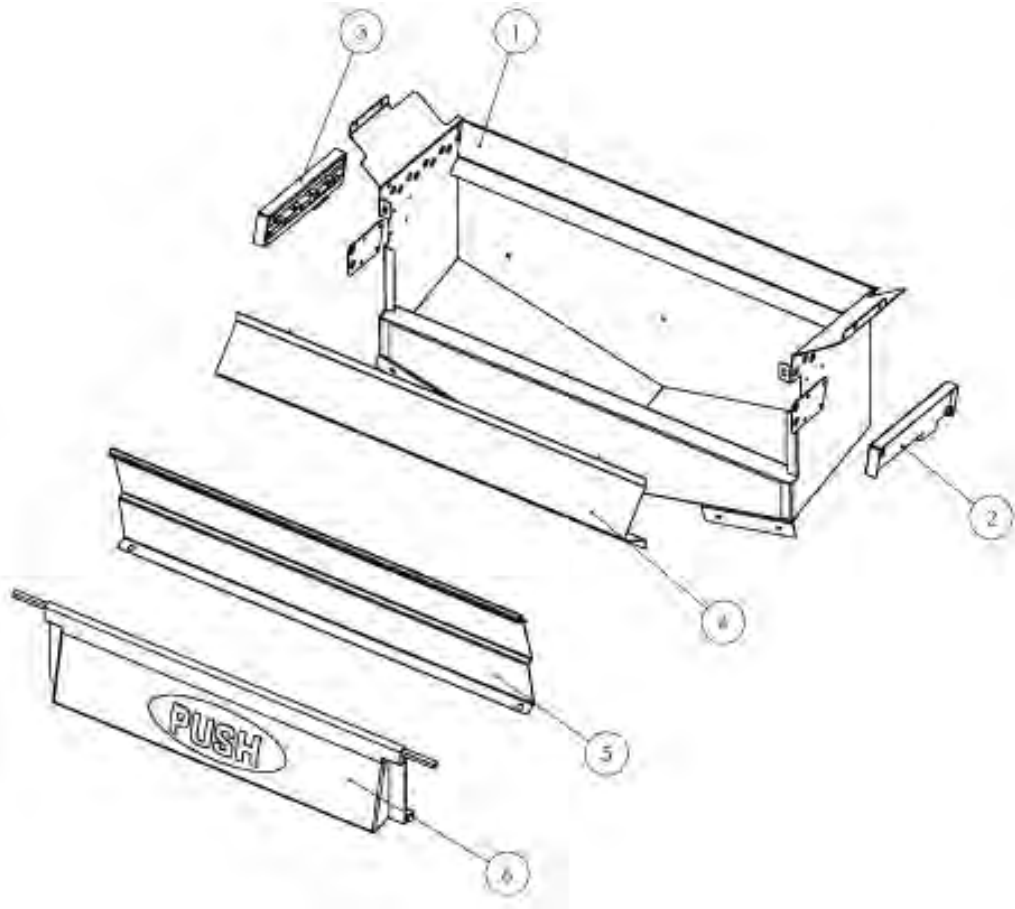
Refrigeration Deck Assembly



Parts List

ITEM	PART NO.	DESCRIPTION
1	STI87029	TRAY, REFRIGERATION DECK
2	SAI87011	DECK HOUSING
3	SAI87051	ASSEMBLY, EVAPORATOR HOUSING
4	REI819	CONDENSER
5	REI830	EVAPORATOR
6	SAI87013	DOOR REFRIGERATION DECK
7	SAI87013	TRAY EVAPORATOR
8	STI87030	TRAY, CONDENSATE
9	STI578	BRACKET, CONDENSER MOTOR
10	STI87019	BRACKET, LATCH CLAMP
11	REI872	COMPRESSOR
12	REI612	MOTOR, CONDENSOR
13	REI861	BLADE, CONDENSOR
14	STI8703T6	L-ANGLE, REF. DECK HOUSING
15	STI87037	SHROUD, CONDENSER
16	STI87038	BRACKET, CONDENSER

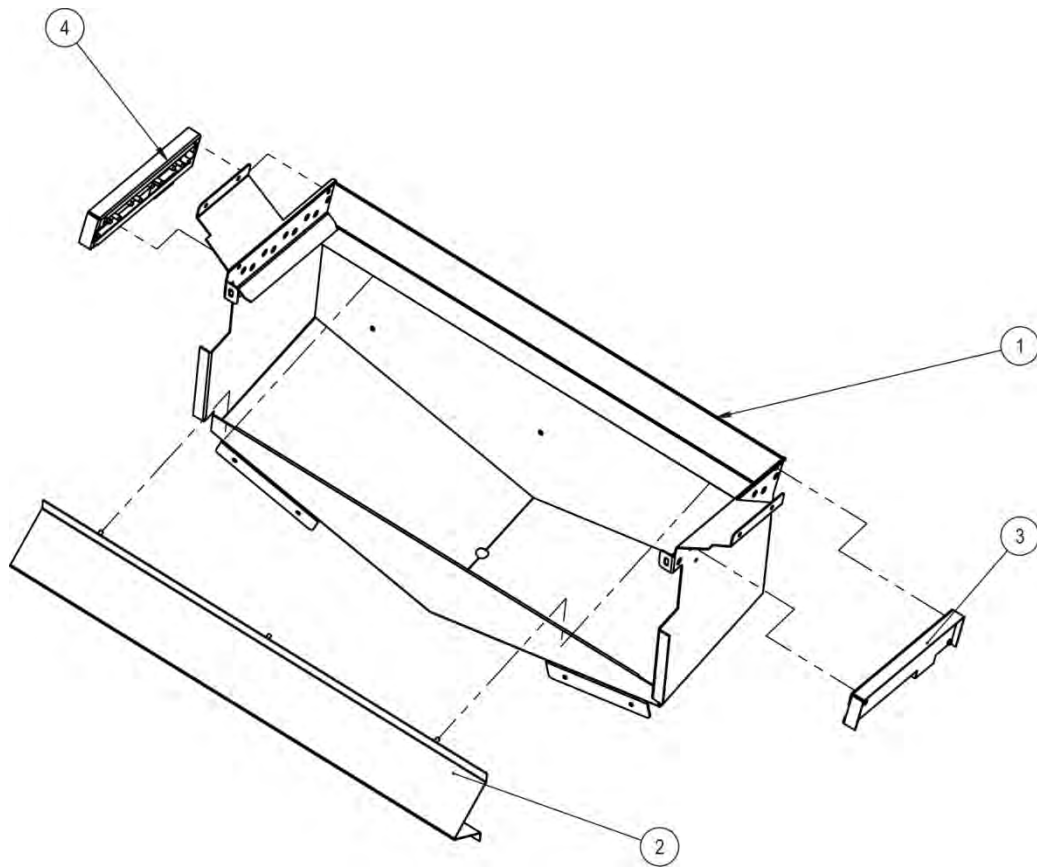
Ambient Delivery Bin Assembly



Parts List

ITEM	PART NO.	DESCRIPTION
1	SAI70009A	DELIVERY BIN ASSEMBLY (5-WIDE)
1	SAI70021A	DELIVERY BIN ASSEMBLY (4-WIDE)
2	SAI775	VEND SENSOR ASSEMBLY, RIGHT
3	SAI779	VEND SENSOR ASSEMBLY, LEFT
4	STI87055	ANTI-THEFT BRACKET (5-WIDE)
4	STI58034	ANTI-THEFT BRACKET (4-WIDE)
5	STI87049	PANEL, DELIVERY BIN (5-WIDE)
5	STI58036	PANEL, DELIVERY BIN (4-WIDE)
6	PLI943A	DELIVERY DOOR (5-WIDE)
6	PLI943	DELIVERY DOOR (4-WIDE)

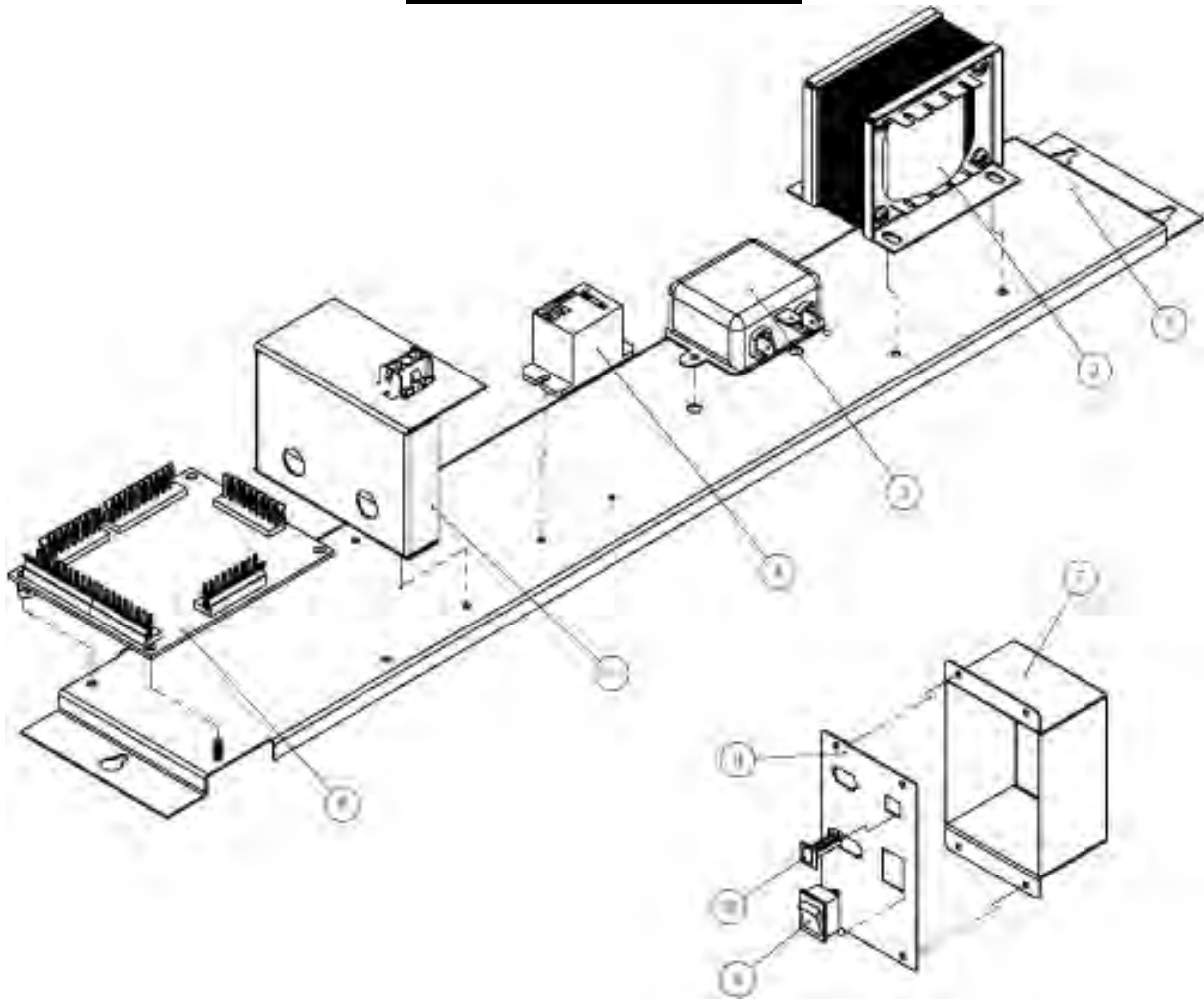
Refrigerated Delivery Bin Assembly



Parts List

ITEM	PART NO.	DESCRIPTION
1	SAI87016	DELIVERY BIN ASSEMBLY (5-WIDE)
1	SAI58010	DELIVERY BIN ASSEMBLY (4-WIDE)
2	STI87055	ANTI-THEFT BRACKET (5-WIDE)
2	STI58034	ANTI-THEFT BRACKET (4-WIDE)
3	SAI775	VEND SENSOR ASSEMBLY, RIGHT
4	SAI779	VEND SENSOR ASSEMBLY, LEFT

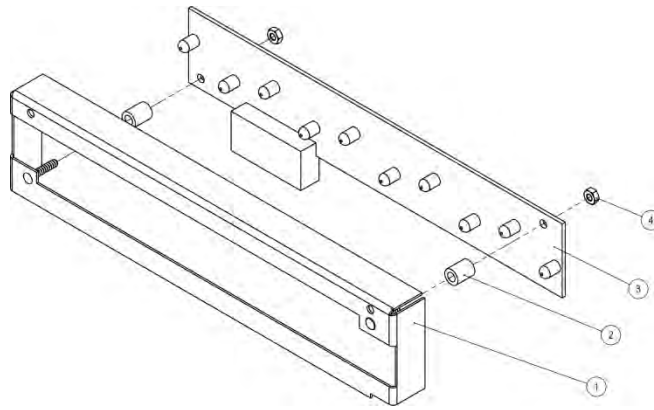
Electrical Panel Assembly



Parts List

ITEM	PART NO.	DESCRIPTION
1	STI87017	ELECTRIC PANEL
2	ELI504A	TRANSFORMER
3	ELI946	FILTER
4	ELI764	RELAY
5	STI84018	SWITCH BRACKET
6	ELI922	AUXILARY BOARD
7	STI84019	POWER BOX
8	STI84020	ELECTRICAL BOX FRONT PLATE
9	ELI916	ON/OFF SWITCH
10	ELI972	CIRCUIT BREAKER

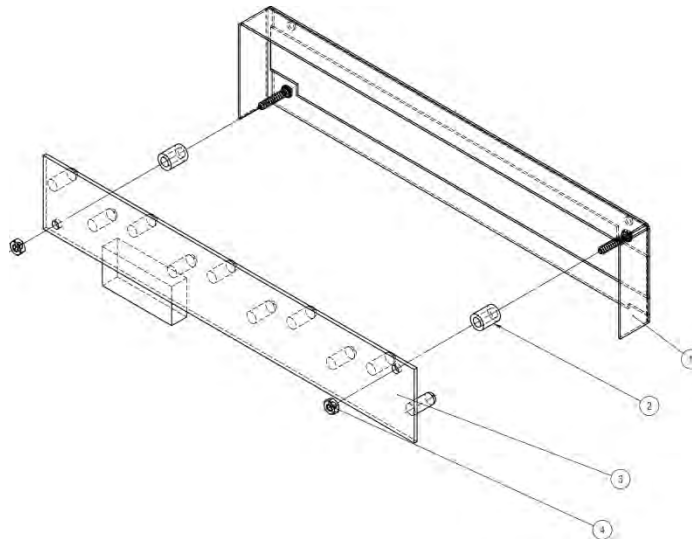
Vigilant Vend Sensor, Right Side Assembly



Parts List

ITEM	PART NO.	DESCRIPTION
1	STI70086	SENSOR BRACKET
2	PLI609A	SPACER
3	ELI974	EMITTER
4	FAI922	NUT

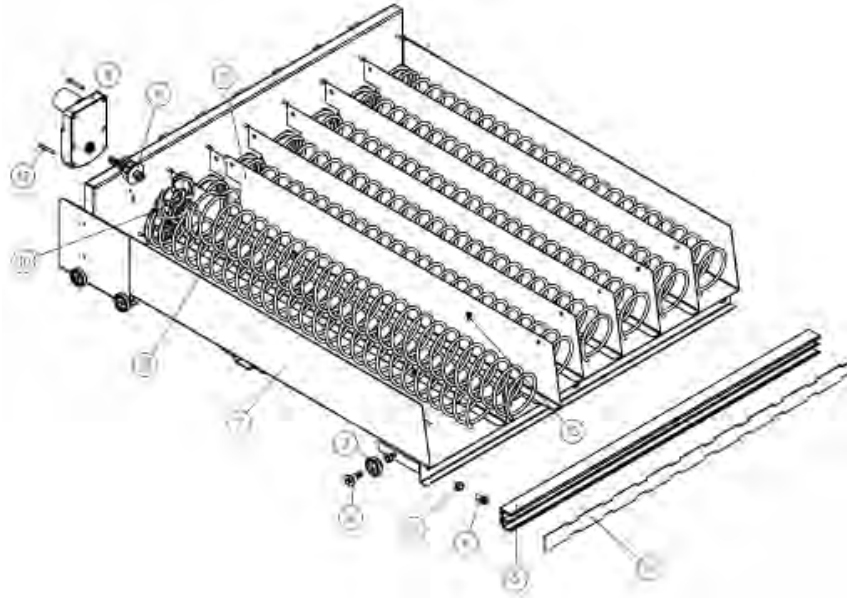
Vigilant Vend Sensor, Left Side Assembly



Parts List

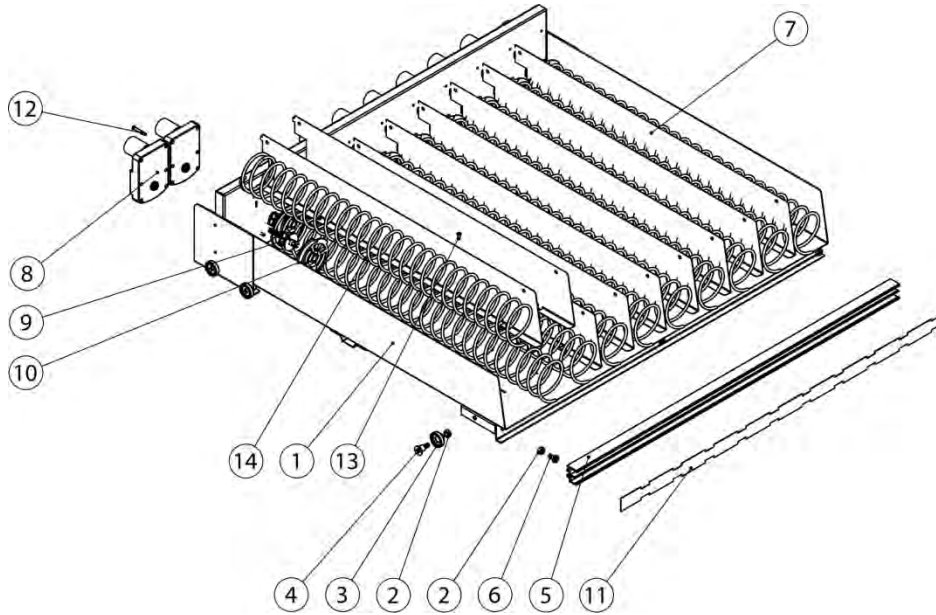
ITEM	PART NO.	DESCRIPTION
1	STI70086	SENSOR BRACKET
2	PLI609A	SPACER
3	ELI2169	DETECTOR
4	FAI922	NUT

8 SpaceTray Assembly, Confectionery (Candy)



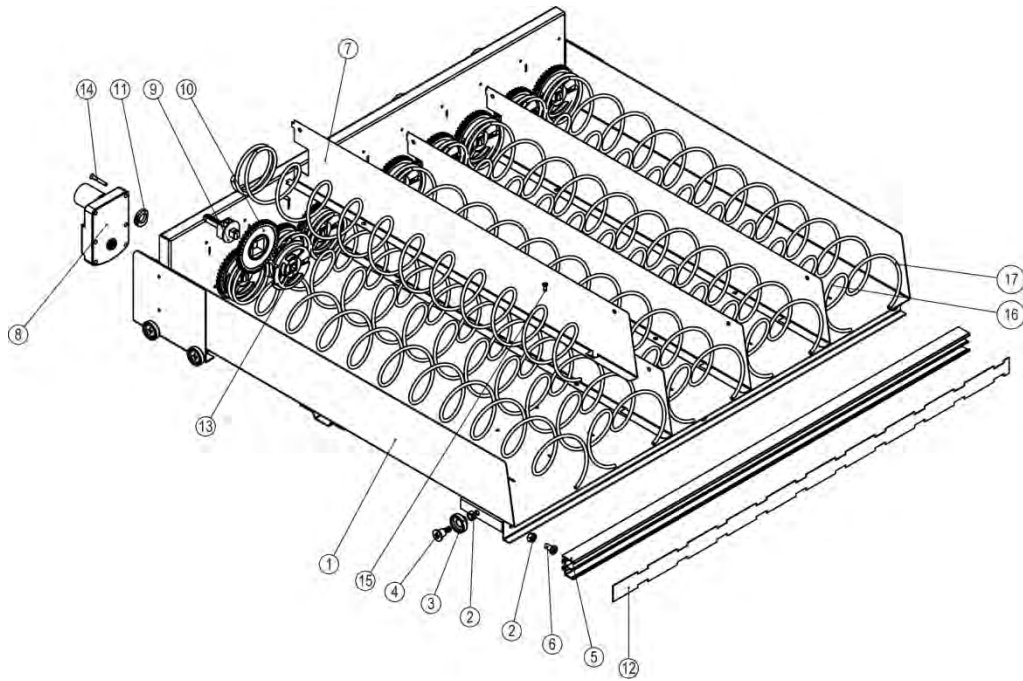
ITEM	PART NO.	DESCRIPTION
1	SAI84024	ASSEMBLY, WELDED TRAY
2	FAI923	NUT, NYLOCK, M6
3	PLI802A	WHEEL, TRAY
4	HAI602	PIN, WHEEL, TRAY
5	PLC958	PROFILE, PRICE SELECTION
6	HAI976	PIN, PROFILE LABEL HOLDING
7	STI70010A	PARTITION, TRAY
8	ELC920	MOTOR
9	PLI721C	SHAFT, GEAR MOTOR
10	PLI331	HUB, COIL, RETAINER
11	PLI84001	STRIP, PRICE SCROLL, HOLDING
12	FAI882	SCREW
13	FAI892	SCREW
14	WFI602	COIL, 18 SPACE, RIGHT
-	WFI552	COIL, 15 SPACE, RIGHT
-	WFI524	COIL, 24 SPACE, RIGHT

10 SpaceTray Assembly, Confectionery (Candy)



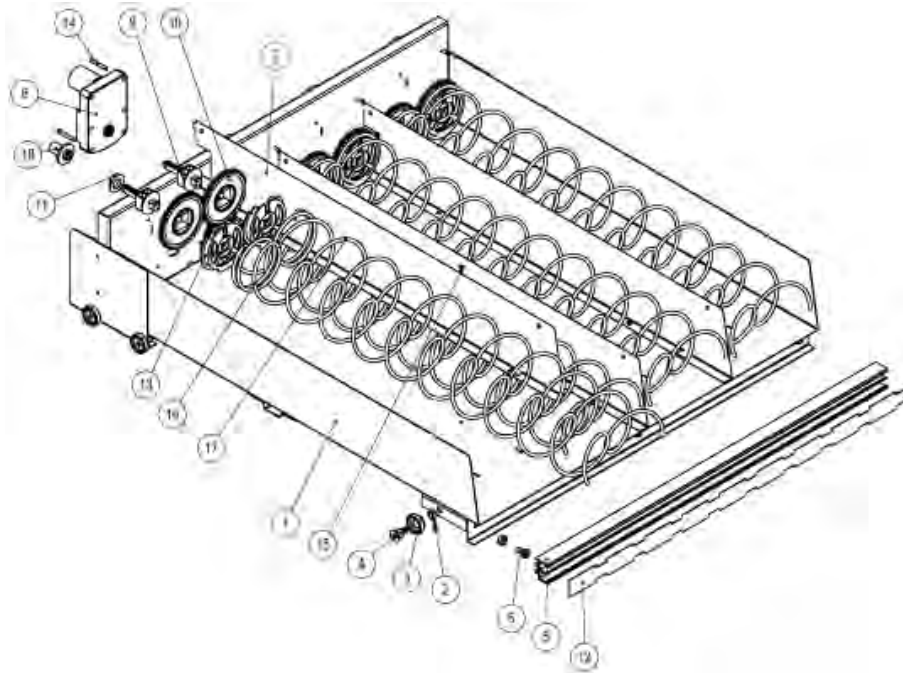
ITEM	PART NO.	DESCRIPTION
1	SAI87041	ASSEMBLY, WELDED TRAY
2	FAI923	NUT, NYLOCK, M6
3	PLI802A	WHEEL, TRAY
4	HAI602	PIN, WHEEL, TRAY
5	PLC958	PROFILE, PRICE SELECTION
6	HAI976	PIN, PROFILE LABEL HOLDING
7	STI70010A	PARTITION, TRAY
8	ELC920	MOTOR
9	PLI721C	SHAFT, GEAR MOTOR
10	PLI331	HUB, COIL, RETAINER
11	PLI87001	STRIP, PRICE SCROLL, HOLDING
12	FAI882	SCREW
13	FAI892	SCREW
14	WFI602	COIL, 18 SPACE, RIGHT
-	WFI552	COIL, 15 SPACE, RIGHT
-	WFI524	COIL, 24 SPACE, RIGHT

5 Space Tray Assembly, Snack Dual Coil



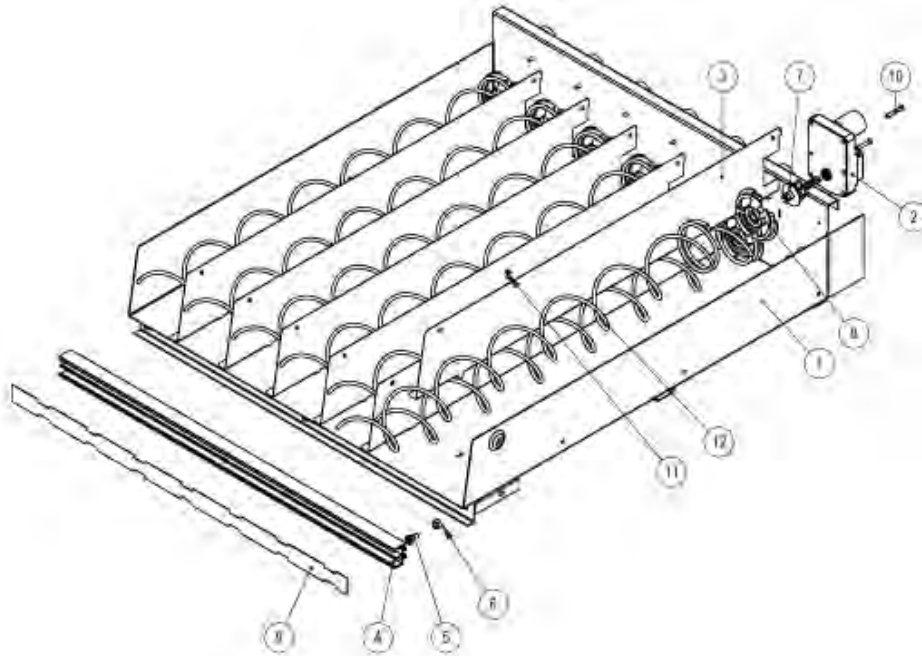
ITEM	PART NO.	DESCRIPTION
1	SAI87041	ASSEMBLY, WELDED TRAY
2	FAI923	NUT, NYLOCK
3	PLI802A	WHEEL, TRAY
4	HAI602	PIN, WHEEL, TRAY
5	PLC958	PROFILE, PRICE SELECTION
6	HAI976	PIN, PROFILE LABEL HOLDING
7	STI70010A	PARTITION, TRAY
8	ELC920	MOTOR
9	PLI721C	SHAFT, GEAR MOTOR
10	PLI536	GEAR
11	PLI332	BUSH, RETAINER
12	PLI87001	STRIP, PRICE SCROLL, HOLDING
13	PLI331	HUB, COIL, RETAINER
14	FAI882	SCREW
15	FAI892	SCREW
16	WFI548	COIL, 10 SPACE, LEFT
-	WFI549	COIL, 10 SPACE, RIGHT
-	WFI568	COIL, 12 SPACE, LEFT
-	WFI59	COIL, 12 SPACE, RIGHT

4 Space Tray Assembly, Snack Dual Coil



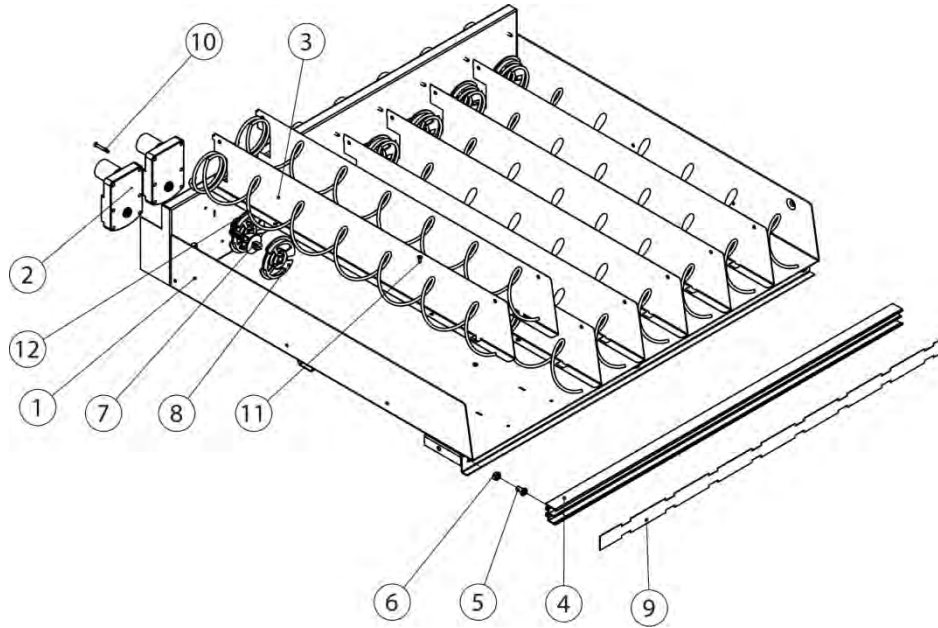
ITEM	PART NO.	DESCRIPTION
1	SAI84024	ASSEMBLY, WELDED TRAY
2	FAI923	NUT, NYLOCK
3	PLI802A	WHEEL, TRAY
4	HAI602	PIN, WHEEL, TRAY
5	PLC958	PROFILE, PRICE SELECTION
6	HAI976	PIN, PROFILE LABEL HOLDING
7	STI70010A	PARTITION, TRAY
8	ELC920	MOTOR
9	PLI721C	SHAFT, GEAR MOTOR
10	PLI536	GEAR
11	PLI332	BUSH, RETAINER
12	PLI84001	STRIP, PRICE SCROLL, HOLDING
13	PLI331	HUB, COIL, RETAINER
14	FAI882	SCREW
15	FAI892	SCREW
16	WFI548	COIL, 10 SPACE, LEFT
-	WFI549	COIL, 10 SPACE, RIGHT
-	WFI568	COIL, 12 SPACE, LEFT
-	WFI59	COIL, 12 SPACE, RIGHT
18	PLI336B	RETAINER SLEEVE, GEAR

7 Space Tray Assembly, Beverage



ITEM	PART NO.	DESCRIPTION
1	SAI84028	ASSEMBLY, WELDED TRAY, 7-SELECTION
2	ELC920	MOTOR
3	STI70010A	PARTITION, TRAY
4	PLC958	PROFILE, PRICE SELECTION
5	HAI976	PIN, PROFILE LABEL HOLDING
6	FAI923	NUT, NYLOCK
7	PLI721C	SHAFT, GEAR MOTOR
8	PLI331	HUB, COIL, RETAINER
9	PLI84002	STRIP, PRICE SCROLL, HOLDING FOR 7 SELECTION TRAY
10	FAI882	SCREW
11	FAI892	SCREW
12	WFI576	COIL, 6 SPACE, RIGHT

8 Space Tray Assembly, Beverage



ITEM	PART NO.	DESCRIPTION
1	SAI87040	ASSEMBLY, WELDED TRAY
2	ELC920	MOTOR
3	STI70010A	PARTITION, TRAY
4	PLC958	PROFILE, PRICE SELECTION
5	HAI976	PIN, PROFILE LABEL HOLDING
6	FAI923	NUT, NYLOCK
7	PLI721C	SHAFT, GEAR MOTOR
8	PLI331	HUB, COIL, RETAINER
9	PLI87001A	STRIP, PRICE SCROLL, HOLDING
10	FAI882	SCREW
11	FAI892	SCREW
12	WFI576	COIL, 6 SPACE, RIGHT

LIMITED WARRANTY

Seaga warrants to the original purchaser that the equipment is free from defects in material and factory workmanship for a period of one (1) year from date of shipment.

This warranty applies only if the equipment has been serviced and maintained in strict accordance with the instructions presented in the Operator's Manual and no unauthorized service, repair, alteration or disassembly has been performed. Any defects caused by improper power source, poor water quality or pressure, an installed water filtration system not fully functioning, abuse of the product, accident, alteration, vandalism, improper service and maintenance schedules, neglecting to de-scale and sanitize on a regular basis, use of products or ingredients not allowed in the machine, corrosion due to use of non-approved detergents or cleaning solutions, or damage incurred during return shipment will not be covered by this warranty. Further, equipment that has had the serial number removed, altered or otherwise defaced will not be covered by this warranty.

Lighting components, refrigerant, glass, paint, decals, fuses, filters or hygiene replacement parts, labor and/or installation are not covered by this warranty.

Follow proper maintenance procedures and use of equipment, as described in the Operator's Manual provided on Seaga's web site at seaga.com, which include but are not limited to:

- Cleaning of equipment including regular maintenance
- Proper installation and location of equipment with respect for the indicated temperature and humidity levels
- Proper use of equipment including loading, programming and setup

THIS WARRANTY IS EXCLUSIVE AND IS GIVEN BY SEAGA AND ACCEPTED BY BUYER IN LIEU OF ANY AND ALL OTHER WARRANTIES, WHETHER EXPRESS OR IMPLIED, INCLUDING, WITHOUT LIMITATION, ALL WARRANTIES OF MERCHANTABILITY AND FITNESS FOR A PARTICULAR PURPOSE. ALL SUCH OTHER WARRANTIES ARE HEREBY EXPRESSLY DISCLAIMED BY SEAGA AND WAIVED BY BUYER. Seaga neither assumes nor authorizes any person to assume for it any obligation or liability in connection with the sale of said unit(s) or any part(s) thereof.

Repair or replacement of proven defective parts is limited to manufacturing defects demonstrated under normal use and service during warranty period. Contact Seaga's Customer Care Department to be assigned a Return Authorization (RA) number. Seaga requires complete information including the serial number(s) of the machine(s), date of purchase and description of the part and/or suspected defect. Seaga may also be contacted, with complete information, by phone: 815.297.9500, by fax: 815.297.1700 and also by email: customercare@seaga.com

Send defective part(s), assembly or complete unit, Attention to the RA Number, prepaid or delivered to:



Seaga will repair or replace, at our option, any covered part which meets the provisions herein during the warranty period. It is our discretion to replace defective parts with comparable parts. Seaga reserves the right to make changes or improvements in its products without notice and without obligation, and without being required to make corresponding changes or improvements in equipment already manufactured or sold.

SMI2456321