



# 9 / 10 Column Mechanical Snack Vendor



## Operator's Manual

Seaga Manufacturing, Inc.  
700 Seaga Drive  
Freeport, IL USA 61032  
[www.seagamfg.com](http://www.seagamfg.com)

## **INTRODUCTION**

Congratulations on the purchase of your new Snack Vendor. This Snack Vendor has been designed to give you many years of dependable service. It requires little maintenance and is easy to set up and operate.

### **READ THIS MANUAL COMPLETELY**

Your Snack Vendor is designed to operate simply and reliably, but to take full advantage of your vendor, please read this owner's manual thoroughly. It contains important information regarding installation and operations, as well as a brief troubleshooting guide.

### **EQUIPMENT INSPECTION**

After you have received your Snack Vendor and have it out of the box, place it on a secure surface for further inspection. **Note:** Any damages that may have occurred during shipping must be reported to the delivery carrier immediately. Reporting damages and the seeking of restitution is the responsibility of the equipment owner. The factory is willing to assist you in this process in any way possible. Feel free to contact our Customer Care Department with any questions you may have on this process.

Once you have your vendor located, we suggest that you keep this manual for future reference, or you can view this manual online at [www.seagamfg.com](http://www.seagamfg.com). Should any problems occur, refer to the section entitled "COMMON QUESTIONS AND ANSWERS". It is designed to help you quickly identify a problem and correct it.

### **MANUFACTURER'S WARRANTY**

#### **WHAT IS COVERED:**

Manufacturer warrants TO THE ORIGINAL PURCHASER ONLY that each item of equipment manufactured is free from defects in material and workmanship under normal use and service. Manufacturer's obligation under this warranty shall be limited to repair or replacement, at our plant, of any parts of the equipment which shall, within one year of the date of shipment to the original purchaser, be demonstrated to be defective. The original purchaser may obtain repair or replacement of the equipment under this warranty by returning the defective item or entire vendor to the Manufacturer, freight pre-paid.

#### **WHAT IS NOT COVERED:**

Manufacturer's warranty obligations DO NOT EXTEND TO OR INCLUDE installation expenses, vandalism, or difficulties resulting from failure to operate equipment in accordance with Manufacturer's instructions under competent supervision and difficulties due to changes in vended products which are beyond the control of Manufacturer.

**SPECIAL NOTE:** Manufacturer is not responsible for any loss of income due to a vending machine being out of service due to a warrantable item.

This warranty is in lieu of all other warranties, expressed or implied, including the warranty of merchantability and fitness or use, and of all other obligations or liabilities on Manufacturer's part. Manufacturer neither assumes, nor authorizes any other person to assume for it, any other liability in connection with the sale of equipment manufactured by itself. This warranty shall not apply to equipment manufactured or any part thereof which is subject to accident, negligence, alteration, abuse, misuse or damage in shipment. The term "original purchaser," as used in this warranty, shall be deemed to mean that person for whom the equipment is originally installed.

Manufacturer is not liable for any incidental, consequential or other damages of any kind whatsoever, directly or indirectly, arising from the use of the equipment whether based upon theories of contract negligence or tort.

**Effective 9/01**

#### **For Technical Support & Service**

#### **Contact our Customer Care Dept.**

8:30 a.m. - 4:00 p.m. CST. Mon thru Fri

815.297.9500 ext 160

815.297.1758 Fax

email: [customer care@seagamfg.com](mailto:customer care@seagamfg.com)

#### **For Parts**

#### **Contact our Parts Dept.**

8:30 a.m. - 4:00 p.m. CST. Mon thru Fri

815.297.9500 ext 160

815.297.1758 Fax

email: [parts@seagamfg.com](mailto:parts@seagamfg.com)



**Seaga Manufacturing, Inc.**

700 Seaga Drive

Freeport, IL 61032 U.S.A.

Online: [www.seagamfg.com](http://www.seagamfg.com)

**9 / 10 Column**  
**Mechanical Snack Vendor**

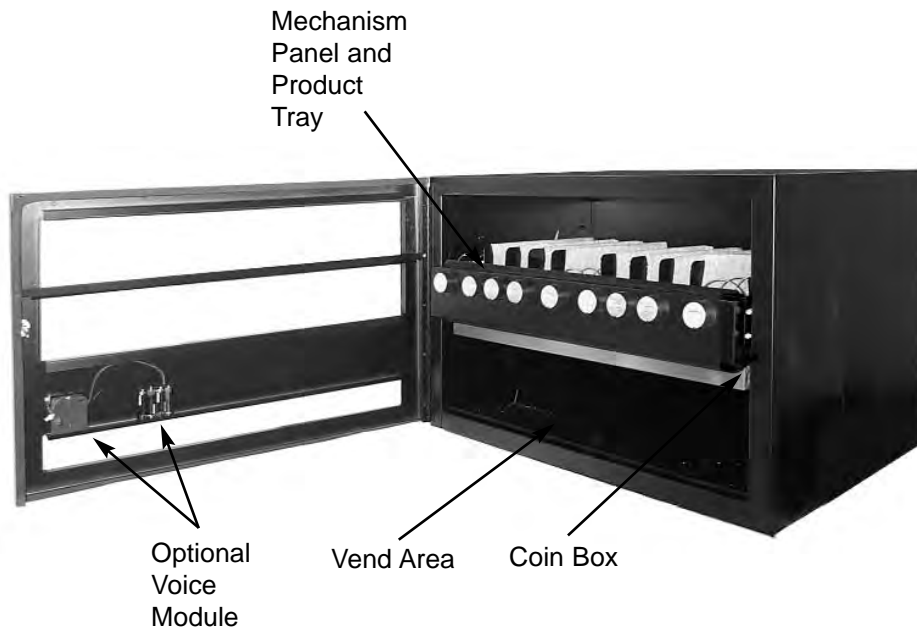
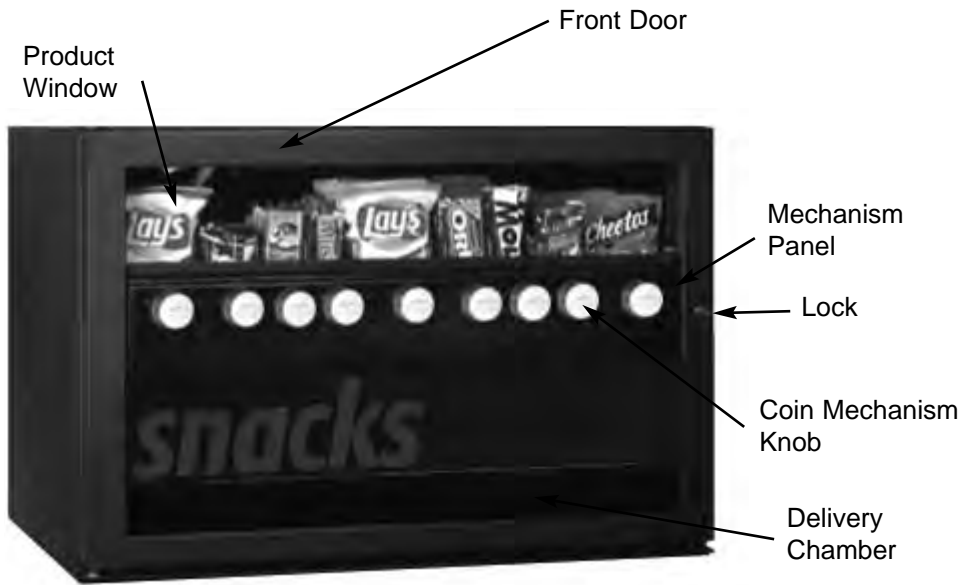

(10 column not shown)

### **LOCKS**

Your vendor has one (1) screw type Lock. To unlock the Front Door, unscrew the Lock counter clockwise until the door is free. To lock, apply firm pressure below the Lock as you tighten the Lock. Do not over tighten as you could ruin the seal. You will be able to remove the key, only when the key is vertical or horizontal.

### **MOUNTING (optional)**

Your vendor offers you many flexible options within your vending environment. The vendor allows the versatility of a stand alone countertop vendor, mounting to the optional stand (Fig. 1), additionally, it may be mounted to the 5 select mechanical soda vendor which allows for optimum use of floor space within the vending environment. Mounting to the soda vendor offers your customers the variety of cold beverages along with their snack purchase.

1. To assemble the CTS stand.

- A.) Attach Legs to short, side supports as shown in Fig. 1, by inserting bolts through Legs, and then attaching support to inside of Leg with nuts.
- B.) Once both ends are assembled attach Front/Rear Supports in same manner, one end at a time.
- C.) Vendor sits atop stand and is held in place by the Rear Legs.

**Note:** The vendor rests on the stand, attaching the stand permanently to the vendor is at the owner's discretion.

*Figure 1* Optional Stand Assembly

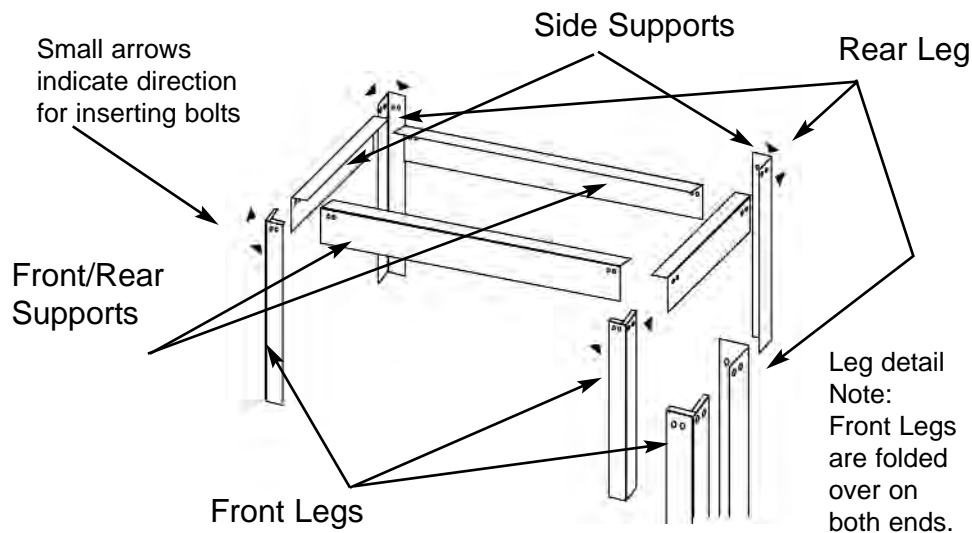

Your vendor can be mounted to the 5 select mechanical soda vendor to form the Mechanical Combination Vendor. The vendor comes with mounting hardware. You will need tools for mounting.

1. To Mount the snack vendor to the soda vendor:

- B.) Set the snack vendor on top of soda vendor.
- C.) Unlock and open the Front Door of the snack vendor. The beverage vendor does not need to be opened.

(The following is to be done inside the snack vendor.)

- D.) Remove bottom Product Tray. Pull Product Tray fully forward, and out.
- E.) Attach the snack vendor to the top of the soda vendor. Insert the two (2) Phillips head screws down through the snack vendor into the threaded holes in the top of the soda vendor.
- F.) Reassemble.

*Figure 2* Optional Soda Vendor Mount

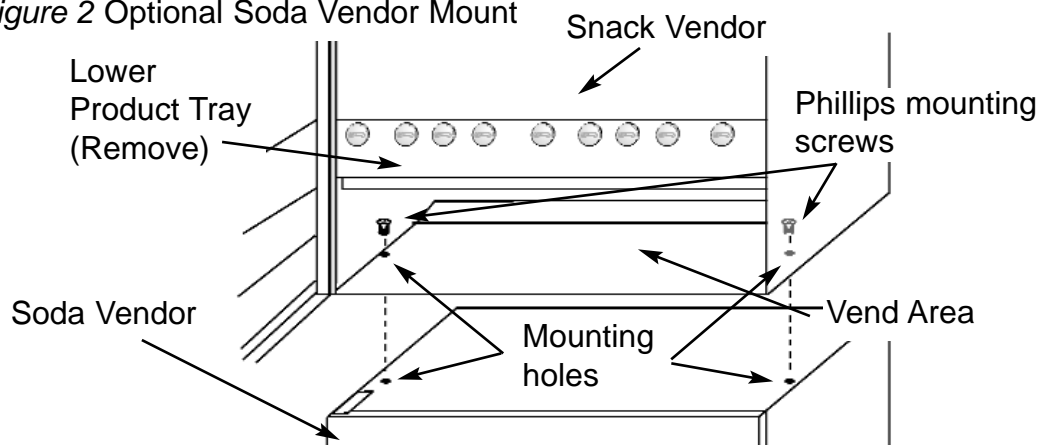

### **DELIVERY SYSTEM**

Your new snack vendor features a rear-drop delivery system to prevent theft. The snack vendor delivery system is made up of three (3) components, the Product Tray, the Helix Coils, and the Coin Mechanism (Fig. 3). Once the proper amount of coins is received the Coin Mechanism drives the Helix Coil and pushes the product out the back of the Product Tray.

*Figure 3 Delivery System*

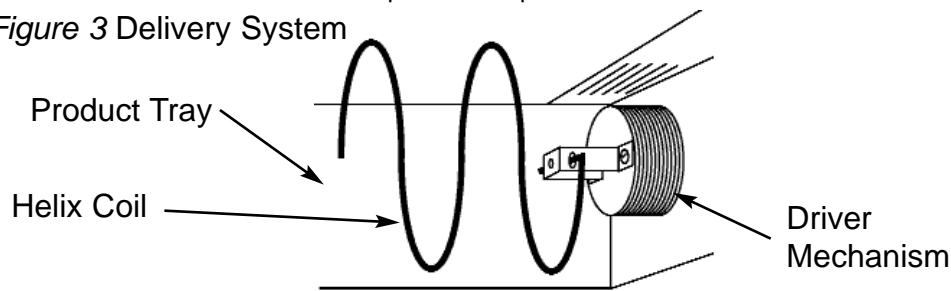

### **DRIVER MECHANISM**

The Mechanism Panel is the front panel. This panel controls the receiving of money and the action of the Helix Coil. Once the correct amount of money is received, the Mechanism Knob can be turned clockwise to the right. Product is vended by turning the Mechanism Knob one (1) complete revolution.

The Driver Mechanism (Fig. 4) comes factory preset, but can be changed to suit your needs. The Coin Sub-Assembly is made up of a series of discs consisting of white, black and metal Coin Discs. The white spacers are thinner than the black, and the combination of the two place the Coin Discs in the proper position to receive coins.

*Figure 4 Driver Mechanism reference*

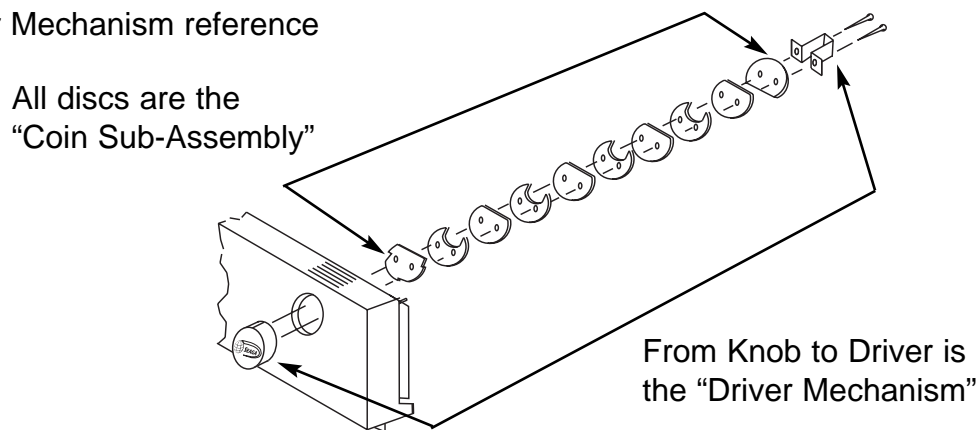

In some cases you will find all one (1) color of spacers. This is common in an all-quarter configuration. Contact our Customer Care Department for additional instructions on changing your Coin Sub-Assembly if necessary.

#### 1. To access Coin Mechanism:

- A.) Unlock and remove Front Door.
- B.) Remove the Mechanism Panel by first removing the two (2) Silver Screws on both sides of the Mechanism Panel.
- C.) Pull the Mechanism Panel outward. Carefully free Drivers from all Helix Coils.
- D.) Turn desired Mechanism Knob clockwise  $\frac{1}{4}$ " turn and place Mechanism Panel face down on a flat surface, exposing the Driver Mechanism and "S" bracket assembly. (Fig. 7)

**Note:** Change one Driver Mechanism at a time.

- E.) To change Driver Mechanisms, remove two (2) nuts (Fig. 5) and gently remove "S" Bracket Assembly.
- F.) Unscrew and remove the two (2) Screws holding Driver to the Coin Sub-Assembly. (Fig. 5 & Fig. 6)
- G.) Coin Sub-Assembly (Fig. 4 & Fig. 6) will come apart from Knob, and can be carefully removed.

#### 2. To assemble Driver Mechanism:

- A.) Lubricate backside of Mechanism Panel around holes with a small amount of petroleum jelly.
- B.) Insert two (2) screws through Coin Sub-Assembly to Knob. Make sure Knob is seated properly and tighten screws into place. If handle is hard to turn, loosen the two (2) screws  $\frac{1}{8}$  to  $\frac{1}{4}$  turn.
- C.) Turn mechanism Knob to align Coin Discs with "S" bracket mounting studs. Install "S" bracket assembly over mounting studs. Do not install the nuts yet.
- D.) Now turn Mechanism Knob so Coin Disc slots are facing down. The Anti-Reverse Dog can now be raised

Figure 5 Inside view of Driver Mechanism

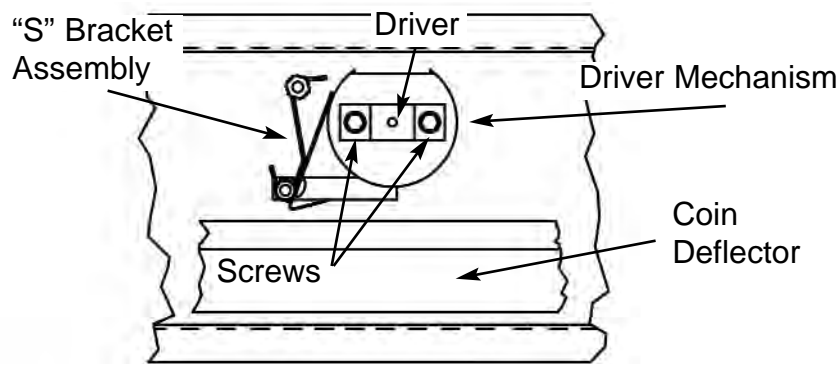

enough to enable the Anti-Reverse Dog Spring to seat under the Anti-Reverse Dog. At the same time the "S" bracket assembly will be seated against Mechanism Panel. Place Keps Nut on upper mounting stud. (DO NOT TIGHTEN NUTS.) (Fig. 4, & Fig. 6)

- E.) Turn Knob to align coin discs with "S" bracket assembly, once again. Use a screwdriver to push top of "S" bracket assembly fully to right and tighten Keps Nut. You may now tighten Nylon Threaded Nut to lower mounting stud. (DO NOT OVER TIGHTEN.)

**Note:** The fingers of the Coin Rejecter must align with Coin Discs of the Coin Sub-Assembly. The Coin Discs strike the center of each finger to prevent vending without coins. **This alignment is critical.** If the fingers are misaligned the vendor will not vend. (Fig 8)

Figure 6 Driver Mechanism exploded view

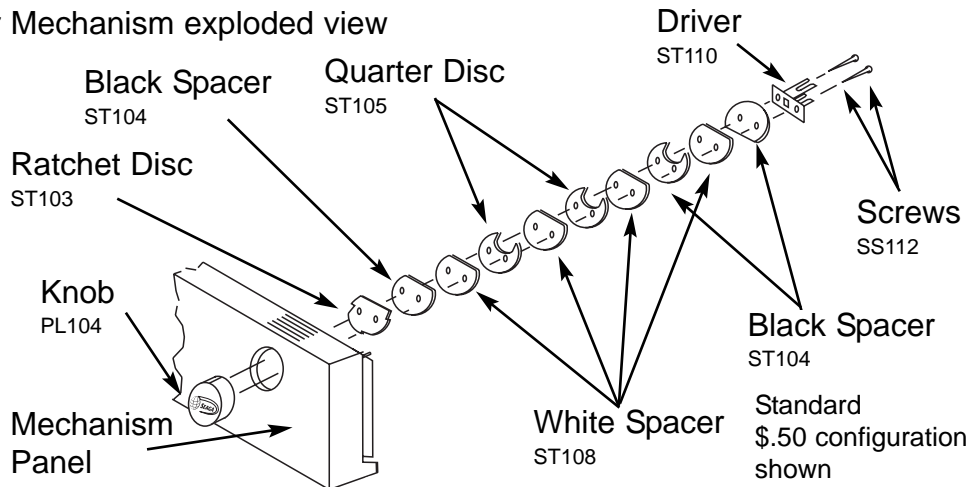

- F.) Check to see that "S" bracket assembly is firmly seated against Mechanism Panel and upper mounting stud. Check that Anti-Reverse Dog Spring is engaged on Anti-Reverse Dog. Make sure Anti-Reverse Dog moves freely and locks into Ratchet Disc as the mechanism is rotated counter-clockwise. If Anti-Reverse Dog does not move freely, loosen Nylon Threaded Nut on the lower mounting stud. If this does not help, remove "S" bracket assembly

Figure 7 "S" Bracket Assembly

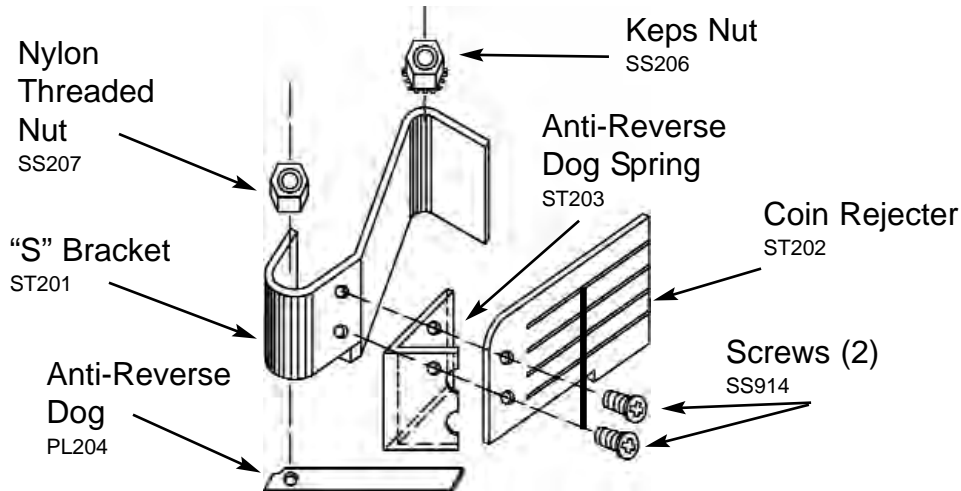

and close Anti-Reverse Dog Spring to put more pressure on Anti-Reverse Dog. Check that coin discs are properly aligned with the Coin Rejecter by inserting money through slots in the top of the Mechanism Panel. Make sure the Coin Rejecter is properly engaging the coin disc stops. (Improper alignment will allow coins to slip between slots in the Coin Rejecter.)

Refer to the optional mechanism configurations at the end of this manual. Always make sure your Driver Mechanism is built as specified in the diagram. **Note:** The disc next to the Driver is always placed upside down (the rounded side will be at the top of the disc only) to prevent coins from jamming the mechanism.

### Figure 8 Proper Finger Alignment

*Figure 8a Accepted!*  
Coins should push the fingers out. Make sure coins contact the center of the fingers.

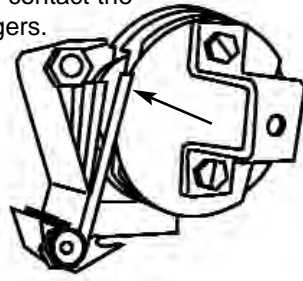

*Figure 8b Vend!*  
Accepted coins push the fingers over the Coin Discs' catches to vend.

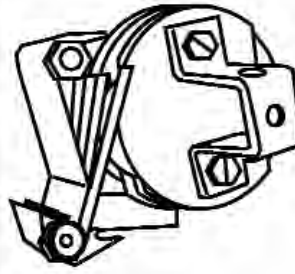

### LOADING PRODUCT

To present your product in as an attractive and professional manner as possible, do not load any damaged items, and make sure items are facing forward for easy identification by your customer.

**Note:** The size of the item being vended must be larger than the Helix Coil but smaller than the Column to vend correctly. Never force an oversized item into the Helix Coil or Column, or attempt to vend an item that is smaller than the Helix Coil as this will create problems and deter customers.

1. To Load Product:

- A.) Pull Product Tray forward.
- B.) Place product in proper size Helix Coil. Note: Bottom of product must rest on the Product Tray and not on the Helix Coil. (Fig.9) Load each Helix Coil from back to front. **Note:** Fill all Helix Coils fully, do not leave any empty spaces behind or between items. If you must leave empty space leave it in the front of the Tray closest to the Product Window.
- C.) Once Product Tray is fully loaded, lift and push it back in.

**Special Note:** We suggest that you always partially fill the vendor with product and perform at least five (5) test vends.

Figure 9 Loading Product



### COIN RETRIEVAL

One (1) Coin Box is provided with your vendor. They are stored below the Product Tray directly behind and below the Coin Mechanisms. Once the Front Door is open, pull out the product tray and then pull the Coin Box out to the right to empty it.

### **OPTIONAL TALKING VENDOR**

The snack vendor can be equipped with a Voice Module to increase sales. The Voice Module consists of three parts, the Voice Box, the Battery Tray and the Record Button. The Voice Module comes with a prerecorded message such as: "Hey, how about a soda, or maybe a snack?" But you can record your own.

*Figure 10* Optional Voice Module

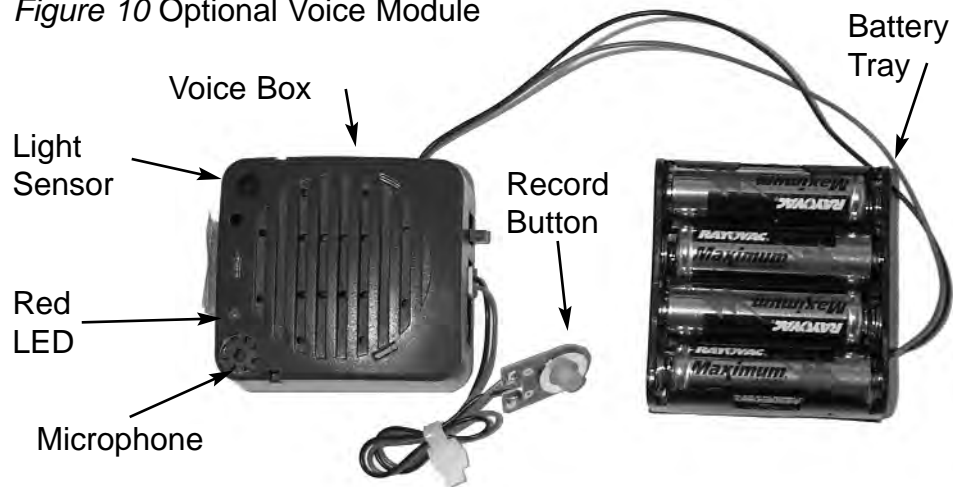

1. To record a new message.
  - A.) Remove the Voice Module and turn it so the Microphone is facing you.
  - B.) Press the Record Button and begin speaking. The Red LED will light up.  
You have 10 seconds of recorded time available.
  - C.) Release the Record Button, the message will play back to you.

*Figure 11* Coin Rejecter Fingers

*Figure 11a* Caught!  
Empty Coin Discs should catch on the center of the Coin Rejecter fingers.



*Figure 11b* Accepted!  
Coins should push the fingers out. Make sure coins contact the center of the fingers.

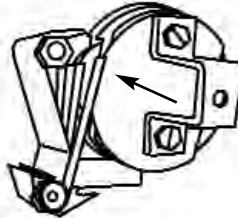

*Figure 11c* Vend!  
Accepted coins push the fingers over the Coin Discs' catches to vend.



### **GENERAL NOTES**

It is suggested that a tool box accompany you to each of your locations. Suggested items for this tool box would include a socket set, (up to a 1/2" socket size suggested) a Phillips and a Standard screwdriver. Additional items would be a small jar of Petroleum Jelly (such as Vaseline), a small brush for applying the Petroleum Jelly, a soft rag and perhaps a black permanent marker. The black marker is useful in touching up light scratches that may occur to your vendor.

### **COMMON QUESTIONS AND ANSWERS**

#### **MAINTENANCE**

- Q: My knob turns without coins.  
A: Your Coin Rejecter is loose, misaligned or broken. Refer to the Driver Mechanism section of this manual for proper placement of the Coin Rejecter. (See Fig. 7 & Fig. 11)
- Q: My mechanism screws keep coming loose.  
A: Remove Mechanism Panel. Disassemble Knob. Apply Lock-Tight to Knob screw threads. If this does not remedy the problem a replacement knob may be needed.
- Q: My mechanism rotates backward.  
A: Your Knob should not do this. Remove the Mechanism Panel and check for



proper placement and condition of the Anti-Reverse Dog.

Q: My mechanism rotates but product will not drop.  
A: Check to see if the product is jammed in the Column.  
Check to see if the vendor is level.  
Check product for damage, and make sure it is the proper size.

Q: My knob turns ¼" turn and jams.  
A: First remove your Mechanism Panel. Check the position of the coins to see if they are in-between the Coin Rejecter fingers. If this is the case, place a screwdriver in-between the Coin Rejecter and the discs and lift up freeing the Coin Rejecter. At this point the Driver Mechanism can now be rotated backwards. Reposition the Coin Rejecter fingers with your screwdriver to line up with coins and vend through. (Fig.10)

### **GENERAL**

Q: Can customers reach up and help themselves to product?  
A: No. The Vendor pushes product out the back of the Product Trays.

Q: My key won't turn my Lock to open.  
A: Check to be sure that you are using the proper key. If the correct key is being used, your Lock may have been damaged or vandalized. Vandalism to locks is quite common. Having spare Locks in your toolbox at all times is recommended.

Q: What can I use to clean the outside of my vendor?  
A: A lint free rag and a mild window cleaner are recommended.  
Be sure however not to directly spray decals as the ink could run.

Q: How do I remove a Lock that won't open.  
A: Drill into the center of the Lock with a 1/4" drill bit. The Lock should fall apart and be easily removed. Increase the bit size and try again if the Lock does not come out.

Q: Why is my Voice Module silent?  
A: Make sure the Voice Module is turned on.  
Record a new message.  
Replace the batteries.

Q: Can the Voice Module store more than one message?  
A: No. The Voice Module can only store 10 seconds of record time.

Figure 12 Optional \$.60 configuration

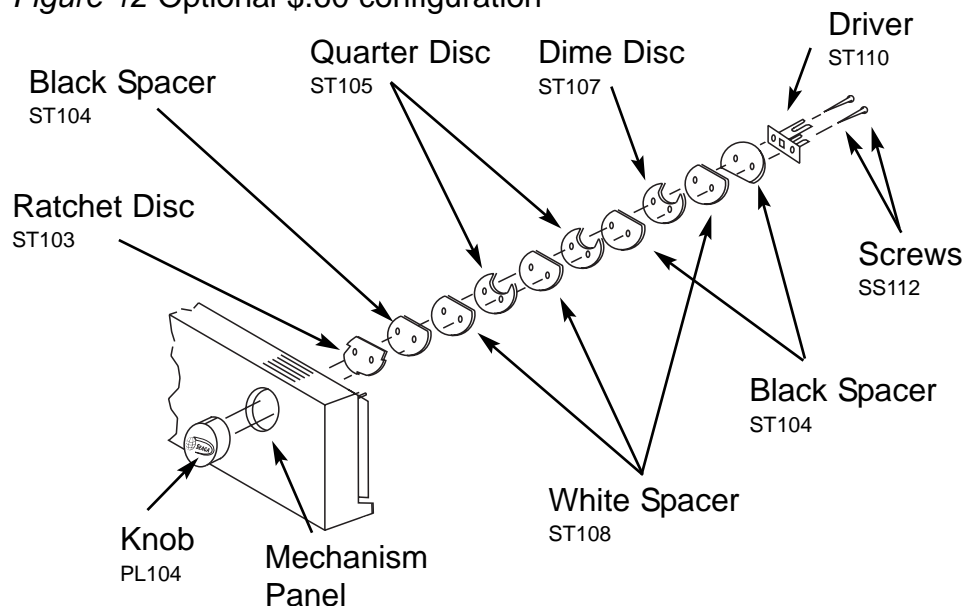

Figure 13 Optional \$.65 configuration

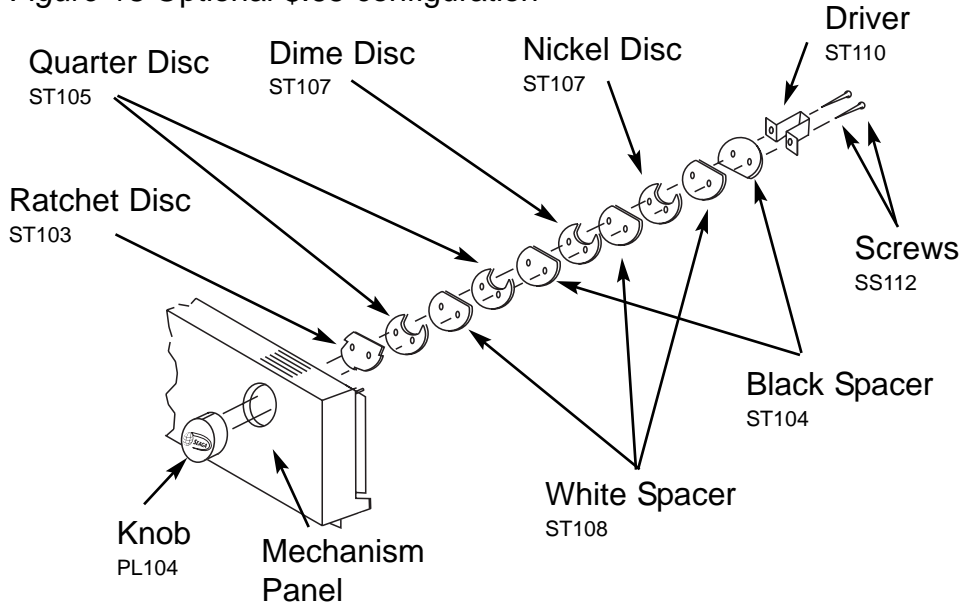

Figure 14 Optional \$.70 configuration

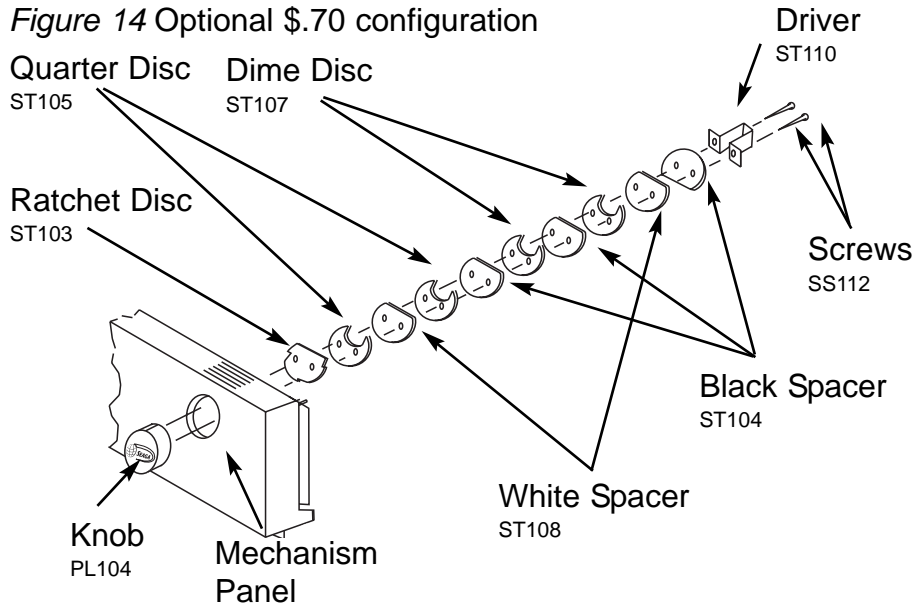

Figure 15 Optional \$.75 configuration

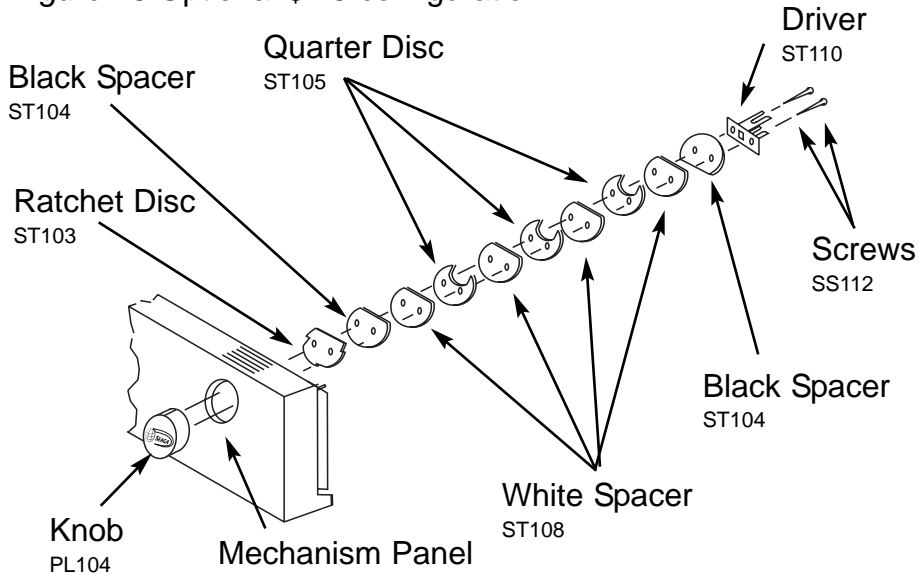

Figure 16 Optional \$.80 configuration

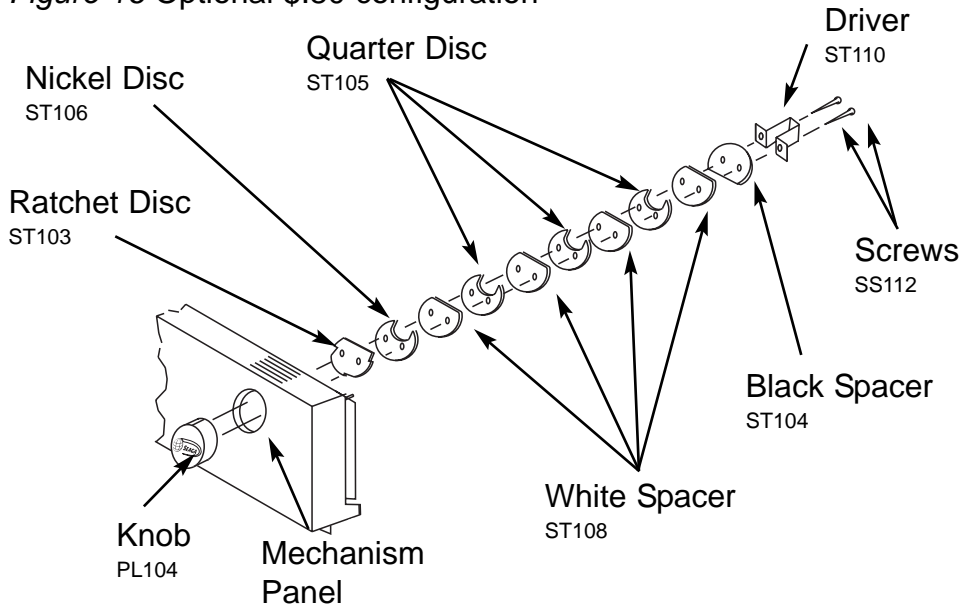

Figure 17 Optional \$1.00 configuration

