

MAY 1996
16-10252

Williams Tales of the **Arabian Nights**



Operators Handbook

WILLIAMS ELECTRONICS GAMES, INC.
3401 N. CALIFORNIA
CHICAGO, IL 60618

TABLE OF CONTENTS

MAIN MENU-----	1
LAMP MATRIX-----	2
LAMP LOCATIONS-----	3
SWITCH MATRIX-----	4
SWITCH LOCATIONS-----	5
SOLENOID TABLE-----	6
SOLENOID LOCATIONS-----	7
UPPER PLAYFIELD PARTS LIST-----	8
UPPER PLAYFIELD PARTS LOCATIONS-----	9
LOWER PLAYFIELD PARTS & LOCATIONS-----	10
RUBBER PARTS-----	11
RAMPS-----	12
FUSE LIST-----	13

MAIN MENU

The Main Menu allows you to choose from several categories, which in turn lead to other menus to choose from. To access the Main Menu, open the coin door and press the Begin Test button, then press the Enter button. Press the Up or Down buttons to cycle through the Main Menu. Press the Enter button to access a menu. Press the Escape button to return to the Main Menu. Press the Start button for HELP at any time.

MAIN MENU

B. BOOKKEEPING MENU

B.1 Main Audits	Press <u>Escape</u>
B.2 Earning Audits	To move out of a menu selection.
B.3 Standard Audits	
B.4 Feature Audits	Press <u>Enter</u>
B.5 Histograms	To get into a menu selection.
B.6 Time-Stamps	

P. PRINTOUTS MENU

P.1 Earnings Data	Press <u>Up</u>
P.2 Main Audits	Increases sequence; Example A.1, A.2, A.3, A.4.
P.3 Standard Audits	Press <u>Down</u>
P.4 Feature Audits	Decreases sequence; Example A.4, A.3, A.2, A.1.
P.5 Score Histograms	
P.6 Time Histograms	Use Up or Down to cycle through the
P.7 Time-Stamps	selections in a menu.
P.8 All Data	

T. TEST MENU

T.1 Switch Edges Test	Use Escape and Enter to move into and out of the
T.2 Switch Levels Test	selected menu.
T.3 Single Switches Test	
T.4 Solenoid Test	
T.5 Flasher Test	
T.6 General Illumination Test	
T.7 Sound and Music Test	
T.8 Single Lamp Test	
T.9 All Lamps Test	
T.10 Lamp and Flasher Test	
T.11 Display Test	
T.12 Flipper Coil Test	
T.13 Ordered Lamps Test	
T.14 Lamp Row-Col.	
T.15 DIP Switch Test	
T.16 Genie/Vanishing Ball Test	
T.17 Empty Balls Test	

U. UTILITIES MENU

U.1 Clear Audits
U.2 Clear Coins
U.3 Reset H.S.T.D.
U.4 Set Time and Date
U.5 Custom Message
U.6 Set Game I.D.
U.7 Factory Adjustments
U.8 Factory Resets
U.9 Presets
U.10 Clear Credits
U.11 Auto Burn-in

A. ADJUSTMENT MENU

A.1 Standard Adjustments
A.2 Feature Adjustments
A.3 Pricing Adjustments
A.4 H.S.T.D. Adjustments
A.5 Printer Adjustments

LAMP MATRIX

Yellow (B+) ① Red

Column Row	1 Yellow-Brown J125-1 Q96	2 Yellow-Red J121-2 Q100	3 Yellow-Orange J121-3 Q95	4 Yellow-Black J121-4 Q99	5 Yellow-Green J121-5 Q94	6 Yellow-Blue J121-6 Q98	7 Yellow-Violet J121-7 Q93	8 Yellow-Gray J121-9 Q97
1 Red-Brown J125-1 Q104	JEWEL 1 (LEFT) 11	JACKPOT 21	MAGIC CARPET 31	SMOKE 6 41	SMOKE 14 (TOP) 51	MAKE A WISH 61	ACTION 2 71	EXTRA BALL 81
2 Red-Black J125-2 Q108	JEWEL 2 12	(G)ENIE 22	ACTION 3 32	SMOKE 7 42	LAMP-15 52	(B)AZAAR 62	LEFT LOCK 72	ACTION 5 82
3 Red-Orange J125-4 Q103	JEWEL 3 13	G(E)NIE 23	RAMP ARROW RIGHT 33	SMOKE 8 43	LAMP-30 53	B(A)ZAAR 63	HAREM ADVANCE 73	RIGHT LOCK 83
4 Red-Yellow J125-5 Q107	JEWEL 4 14	GE(N)IE 24	RAMP ARROW LEFT 34	SMOKE 9 44	LAMP-60 54	BA(Z)AAR 64	LEFT TIGER LOOP 74	RIGHT TIGER LOOP 84
5 Red-Green J125-6 Q102	JEWEL 5 15	GEN(I)E 25	SMOKE 1 (BOTTOM) 35	SMOKE 10 45	SMOKE 4 55	BAZ(A)AR 65	ACTION 1 75	CAPTIVE BALL RIGHT 85
6 Red-Blue J125-7 Q106	JEWEL 6 16	GEN(I)E 26	SMOKE 2 36	SMOKE 11 46	SMOKE 5 56	BAZA(A)R 66	WISH 1 76	ACTION 4 86
7 Red-Violet J125-8 Q101	JEWEL 7 (RIGHT) 17	MULTIBALL 27	SMOKE 3 37	SMOKE 12 47	SHOOT STAR RIGHT 57	BAZAA(R) 67	WISH 2 77	CAPTIVE BALL LEFT 87
8 Red-Gray J125-9 Q105	SHOOT AGAIN 18	OUTLANE SPECIAL 28	AMULET 38	SMOKE 13 48	SHOOT STAR LEFT 58	CENTER LOCK 68	WISH 3 78	START BUTTON 88

J1XX = Power Driver Board

LAMP LOCATIONS

Item No.	Bulb No.	Lamp Assy No.	Description
11	24-8768	A-20750	Jewel 1 (left)
12	24-8768	A-20750	Jewel 2
13	24-8768	A-20750	Jewel 3
14	24-8768	A-20750	Jewel 4
15	24-8768	A-20750	Jewel 5
16	24-8768	A-20750	Jewel 6
17	24-8768	A-20750	Jewel 7 (right)
18	24-6549	A-17835	Shoot Again
21	24-8768	A-20741	Jackpot
22	24-8768	A-20741	(G)enie
23	24-8768	A-20741	G(E)nie
24	24-8768	A-20741	Ge(N)ie
25	24-8768	A-20741	Gen(I)e
26	24-8768	A-20741	Geni(E)
27	24-6549	A-17807	MultiBall
28	24-6549	A-17835	Outlane Special (2)
31	24-8768	A-20747	Magic Carpet
32	24-8768	A-20747	Action 3
33	24-8768	A-20747	Ramp Arrow Right
34	24-8768	A-20747	Ramp Arrow Left
35	24-8768	A-20742	Smoke 1 (bottom)
36	24-8768	A-20742	Smoke 2
37	24-8768	A-20742	Smoke 3
38	24-6549	A-17807	Amulet
41	24-8768	A-20745	Smoke 6
42	24-8768	A-20745	Smoke 7
43	24-8768	A-20745	Smoke 8
44	24-8768	A-20745	Smoke 9
45	24-8768	A-20745	Smoke 10
46	24-8768	A-20745	Smoke 11
47	24-8768	A-20745	Smoke 12
48	24-8768	A-20745	Smoke 13
51	24-8768	A-20747	Smoke 14 (top)
52	24-8768	A-20747	Lamp 15
53	24-8768	A-20747	Lamp 30
54	24-8768	A-20747	Lamp 60
55	24-8768	A-20749	Smoke 4
56	24-8768	A-20749	Smoke 5
57	24-8768	A-20749	Shoot Star Right
58	24-6549	A-17807	Shoot Star Left
61	24-8768	A-20744	Make A Wish
62	24-8768	A-20744	(B)azaar
63	24-8768	A-20744	B(A)azaar
64	24-8768	A-20744	Ba(Z)aar
65	24-8768	A-20744	Baz(A)ar
66	24-8768	A-20744	Baza(A)r
67	24-8768	A-20744	Bazaa(R)
68	24-6549	A-17835	Center Lock
71	24-8768	A-20746	Action 2
72	24-8768	A-20746	Left Lock
73	24-8768	A-20746	Harem Advance
74	24-8768	A-20746	Left Tiger Loop
75	24-8768	A-20746	Action 1
76	24-8768	A-20748	Wish 1
77	24-8768	A-20748	Wish 2
78	24-8768	A-20748	Wish 3
81	24-8768	A-20743	Extra Ball
82	24-8768	A-20743	Action 5
83	24-8768	A-20743	Right Lock
84	24-8768	A-20743	Right Tiger Loop
85	24-8768	A-20743	Captive Ball Right
86	24-6549	A-17835	Action 4
87	24-6549	A-17835	Captive Ball Left
88	-----	20-9663-1	Start Button

24-6549 = #44 Bulb

24-8768 = #555

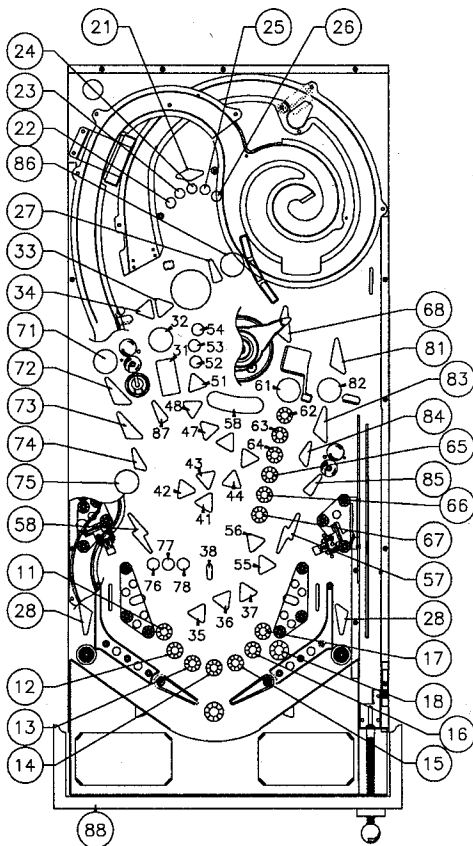

SWITCH MATRIX

Dedicated Grouped Switches	Column Row	White \rightarrow \leftarrow Green								Flipper Grouped Switches
		1 Green-Brown J206-1 U20-18	2 Green-Red J206-2 U20-17	3 Green-Orange J206-3 U20-16	4 Green-Yellow J206-4 U20-15	5 Green-Black J206-5 U20-14	6 Green-Blue J206-6 U20-13	7 Green-Violet J206-7 U20-12	8 Green-Gray J206-9 U20-11	
Orange-Brown J205-1 Left Coin Chute U17-5 D1	1 White-Brown J208-1 U18-11	1 HAREM PASSAGE	2 SLAM TILT	3 TROUGH EJECT	4 RAMP MADE LEFT	5 LEFT SLING	6 LEFT STANDUPS	7 NOT USED	8 NOT USED	Black-Green J208-13 Lower Right Flipper E.O.S. F1
Orange-Red J205-2 Center Coin Chute U17-7 D2	2 White-Red J208-2 U18-9	2 VANISH TUNNEL	2 COIN DOOR CLOSED	3 TROUGH BALL	5 GENIE TARGET	6 RIGHT SLING	6 RIGHT STANDUPS	7 NOT USED	8 NOT USED	Blue-Violet J212-12 Lower Right Flipper Opto F2
Orange-Black J205-3 Right Coin Chute U17-11 D3	3 White-Orange J208-3 U19-5	3 START BUTTON	5 GENIE STANDUP TARGET	3 TROUGH BALL	4 LEFT LOOP	5 LEFT JET	6 TOP SKILL	7 NOT USED	8 NOT USED	Black-Blue J208-12 Lower Left Flipper E.O.S. F3
Orange-Yellow J205-4 4th Coin Chute U17-9 D4	4 White-Yellow J208-4 U18-7	4 PLUMB BOB TILT	4 ALWAYS CLOSED	3 TROUGH BALL	4 INNER LOOP LEFT	5 RIGHT JET	6 MIDDLE SKILL	7 NOT USED	8 NOT USED	Blue-Gray J212-11 Lower Left Flipper Opto F4
Orange-Green J205-5 Normal Function Svc Crdts Escape D5	5 White-Green J208-5 U19-11	5 RAMP ENTER	5 BAZAAR EJECT	4 TROUGH BALL	4 INNER LOOP RIGHT	5 MIDDLE JET	6 BOTTOM SKILL	7 NOT USED	8 NOT USED	Black-Violet J208-11 Upper Right Flipper E.O.S. F5
Orange-Blue J205-7 U16-11 Normal Function Volume Dn Down D6	6 White-Blue U208-7 U19-9	6 LEFT OUTLANE	6 LEFT INLANE	6 LEFT CAGE OPTO	6 MINI STANDUPS	6 LAMP SPIN CCW	6 LOCK 1 (BOTTOM)	7 NOT USED	8 NOT USED	Black-Yellow J212-10 Upper Right Flipper Opto F6
Orange-Violet J205-8 U16-7 Normal Function Volume Up Up D7	7 White-Violet J208-8 U19-5	7 RIGHT INLANE	7 RIGHT OUTLANE	7 RIGHT CAGE OPTO	7 RAMP MADE RIGHT	7 LAMP SPIN CW	7 LOCK 2 (MIDDLE)	8 NOT USED	8 NOT USED	Black-Gray J208-10 Upper Left Flipper E.O.S. F7
Orange-Gray J205-9 U16-5 Normal Function Begin Test Enter D8	8 White-Gray J208-9 U19-7	8 BALL SHOOTER	8 LEFT WIRE MAKE	8 LEFT EJECT	8 RIGHT CAPTIVE BALL	8 LEFT CAPTIVE BALL	8 LOCK 3 (TOP)	8 NOT USED	8 NOT USED	Black-Blue J212-9 Upper Left Flipper Opto F8

J2XX = CPU BOARD = OPTO, TYPICALLY CLOSED

SWITCH LOCATIONS

Item No.	Switch No.	Description
F1	SW-1A-194	Lower Right Flipper E.O.S.
F2	A-17316	Lower Right Flipper Cabinet.
F3	SW-1A-194	Lower Left Flipper E.O.S.
F4	A-17316	Lower Left Flipper Cabinet
F5	Not Used	Upper Right Flipper E.O.S.
F6	Not Used	Upper Right Flipper Cabinet
F7	Not Used	Upper Left Flipper E.O.S.
F8	Not Used	Upper Left Flipper Cabinet
11	A-12238	Harem Passage
12	A-12238	Vanish Tunnel
13	20-9669-1	Start Button
14	04-10346	Plumb Bob Tilt*
15	5647-12693-36	Ramp Enter
16	A-16443	Left Outlane
17	A-17813	Right Inlane
18	A-20842	Ball Shooter
21	A-17238	Slam Tilt*
22	5643-09268-00	Coin Door Closed*
23	A-18530-6	Genie Standup
24	5643-09112-00	Always Closed*
25	5647-12693-13	Bazaar Eject
26	A-17813-1	Left Inlane
27	A-16443	Right Outlane
28	5647-12693-21	Left Wire Make
31	A-18617-1 (LED)	Trough Eject
32	A-18618-1 (photo trans.)	Trough Ball 1
33	A-18617-1 (LED)	Trough Ball 2
34	A-18618-1 (photo trans.)	Trough Ball 3
35	A-18617-1 (LED)	Trough Ball 4
36	A-18618-1 (photo trans.)	Trough Ball 4
36	A-16908 (LED)	Left Cage Opto
37	A-16909 (photo trans.)	Right Cage Opto
38	A-16908 (LED)	Right Cage Opto
41	A-16909 (photo trans.)	Left Eject
42	A-12238	Ramp Made Left
43	SW-1A-207 (left)	Genie Target
44	SW-1A-208 (right)	Genie Target
43	A-17813	Left Loop
44	A-17813	Inner Loop Left
45	A-17813	Inner Loop Right
46	A-18017-6	Mini Standups (3)
47	A-12238	Ramp Made Right
48	A-18530-6	Right Captive Ball
51	A-17800 (Kick)	Left Slingshot
52	A-17793 (Score)**	Left Slingshot
52	A-17800 (Kick)	Right Slingshot
53	A-17793 (Score)**	Right Slingshot
53	A-16443	Left Jet Bumper
54	A-16443	Right Jet Bumper
55	A-16443	Middle Jet Bumper
56	SW-1A-206	Lamp Spin CCW
57	SW-1A-206	Lamp Spin CW
58	A-18530-6	Left Captive Ball
61	A-20846-9 (top)	Left Standups
62	A-20499-9 (middle)	Left Standups
62	A-20499-9 (bottom)	Left Standups
62	A-20846-9 (top)	Right Standups
62	A-20499-9 (middle)	Right Standups
62	A-20499-9 (bottom)	Right Standups
63	SW-1A-202-15	Top Skill
64	SW-1A-202-15	Middle Skill
65	SW-1A-202-15	Bottom Skill
66	A-17985-R	Lock 1 (bottom)
67	A-14820	Lock 2 (middle)
68	A-14820	Lock 3 (top)
71 to 88	Not Used	

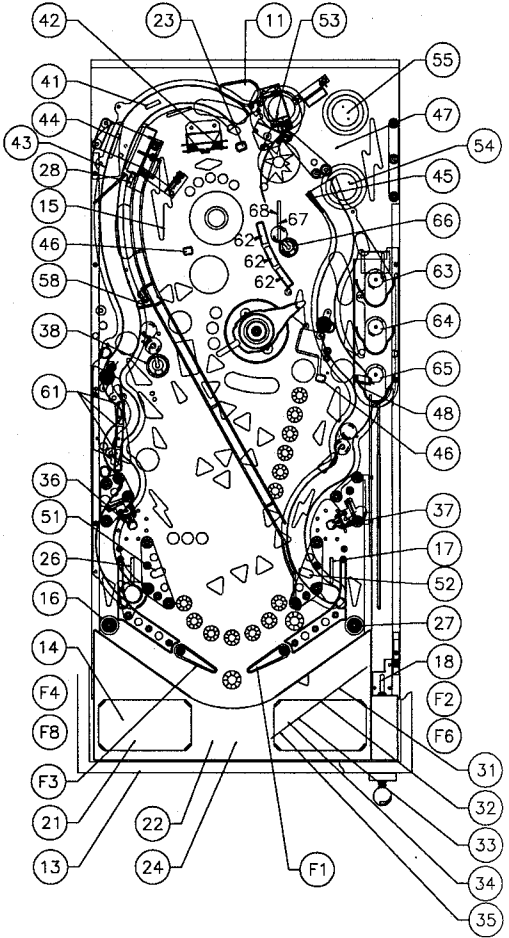

*NOT SHOWN. **SCORE SWITCHES HAVE DIODES ATTACHED.

SOLENOID TABLE

Sol. No.	Function	Solenoid Type	Voltage Connections			Drive Xistor	Drive Connections			Drive Wire Color	Solenoid Part Number	
			Playfield	Backbox	Cabinet		Playfield	Backbox	Cabinet		Playfield	Backbox
01	LEFT CAGE	High Power	J133-2			Q72	J116-1			Vio-Brn	A-20099	
02	RIGHT CAGE	High Power	J133-2			Q68	J116-2			Vio-Red	A-20099	
03	VANISH DROP	High Power	J133-2			Q71	J116-4			Vio-Org	FL-11763	
04	LOCK EJECT	High Power	J133-2			Q67	J116-5			Vio-Yel	AE-27-1200	
05	BAZAAR EJECT	High Power	J133-2			Q70	J116-6			Vio-Grm	AE-25-1000	
06	LOCK MAGNET	High Power	J133-2			Q66	J116-7			Vio-Blu	20-10197	
07	KNOCKER	High Power		J133-2		Q69		J116-8		Vio-Blk		AE-23-800
08	RAMP MAGNET COIL	High Power	J133-1			Q65	J116-9			Vio-Gry	20-10179	
09	TROUGH EJECT	Low Power	J133-3			Q44	J113-1			Brn-Blk	AE-26-1500	
10	LEFT SLINGSHOT	Low Power	J133-3			Q48	J113-3			Brn-Red	AE-27-1200	
11	RIGHT SLINGSHOT	Low Power	J133-3			Q43	J113-4			Brn-Org	AE-27-1200	
12	LEFT JET BUMPER	Low Power	J133-3			Q47	J113-5			Brn-Yel	AE-26-1200	
13	RIGHT JET BUMPER	Low Power	J133-3			Q42	J113-6			Brn-Grm	AE-26-1200	
14	MIDDLE JET BUMPER	Low Power	J133-3			Q46	J113-7			Brn-Blu	AE-26-1200	
15	LEFT KICKER	Low Power	J133-3			Q41	J113-8			Brn-Vio	AE-27-1200	
16	LEFT EJECT FLASHER	Low Power	J133-6	J134-5		Q45	J113-9	J114-5		Brn-Gry	#89 (2)	#906
17	INLANE FLASHERS	Flasher	J133-6			Q28	J111-1			Blk-Brn	#89 (2)	
18	FINAL BATTLE FLASHER	Flasher	J133-6			Q32	J111-2			Blk-Red	#906	
19	LEFT LOOP FLASHER	Flasher	J133-6			Q27	J111-3			Blk-Org	#906	
20	BAZAAR FLASHER	Flasher	J133-6			Q31	J111-4			Blk-Yel	#89	
21	RAMP DIVERTER	Low Power	J133-2			Q26	J111-5			Blu-Grm	AE-30-2000	
22	RUB LAMP FLASHER	Flasher	J133-6			Q30	J111-6			Blu-Blk	#906	
23	MAGIC LAMP FLASHERS	Flasher	J133-6			Q25	J111-7			Blu-Vio	#906	
24	RIGHT LOOP FLASHER	Flasher	J133-6			Q29	J111-8			Blu-Gry	#906	
25	START TALE FLASHERS	Gen. Purpose	J133-6	J134-5		Q16	J109-1	J108-1		Blu-Brn	#906	#906
26	JET FLASHERS	Gen. Purpose	J133-6	J134-5		Q15	J109-2	J108-2		Blu-Red	#906	#906
27	TOP LOOP FLASHER	Gen. Purpose	J133-6	J134-5		Q14	J109-3	J108-3		Blu-Org	#906	#906
28	RAMP FLASHER	Gen. Purpose	J133-6			Q13	J109-4			Blu-Yel	#906	

General Illumination												
01	ILLUMINATION STRING 1	G.I.		J106-1		Q5		J106-7			Wht-Brn	#44
02	ILLUMINATION STRING 2	G.I.		J106-2		Q4		J106-8			Wht-Org	#44
03	ILLUMINATION STRING 3	G.I.		J106-3		Q3		J106-9			Wht-Yel	#44
04	ILLUMINATION STRING 4	G.I.	J105-5			Q2	J105-10				Wht-Grm	#555
05	ILLUMINATION STRING 5	G.I.	J105-6		J104-3	Q1	J105-11		J104-1		Wht-Vio	#555

Flipper Circuits		Voltage Connection		Drive Transistors		Drive Connections		Drive Wire Colors		Coil Part No.	Coil Colors
		Playfield	Power	Power	Hold	Playfield	Power	Power	Hold		
29		Lwr. Rt. Power	J119-1 (Red-Grn)	Q90			J120-13	Yel-Grn		FL-11629	BLUE
30	LOWER RIGHT FLIPPER	Lwr. Rt. Hold	J119-1 (Red-Grn)	Q92			J120-11	Org-Grn			
31		Lwr. Lt. Power	J119-4 (Red-Blu)	Q87			J120-9	Yel-Blu		FL-11629	BLUE
32	LOWER LEFT FLIPPER	Lwr. Lt. Hold	J119-4 (Red-Blu)	Q89			J120-7	Org-Blu			
33	LEFT DIVERTER POWER	Upr. Rt. Power	J119-6 (Red-Vio)	Q84			J120-6	Yel-Vio		FL-11753	YELLOW
34	LEFT DIVERTER HOLD	Upr. Rt. Hold	J119-6 (Red-Vio)	Q86			J120-4	Org-Vio			
35	VANISH MAGNET	Upr. Lt. Power	J119-8 (Red-Gry)	Q81			J120-3	Yel-Gry		20-10197	
36	LOOP POST DIVERTER	Upr. Lt. Hold	J119-8 (Red-Gry)	Q83			J120-1	Org-Gry		AE-27-1200	

J1XX = POWER DRIVER BOARD
 24-6549 = #44 BULB; 24-8704 = #89 BULB; 24-8768 = #555 BULB; 24-8802 = #906 BULB
 *THESE G.I. STRINGS DO NOT BRIGHTEN AND DIM, THEY ARE ALWAYS ON.

SOLENOID LOCATIONS

Item No.	Coil/Flasher Number	Assembly Number	Description
01	A-20099	A-20693	Left Cage
02	A-20099	A-20693	Right Cage
03	FL-11753	A-20644	Vanish Drop
04	AE-27-1200	B-9362-L-3	Lock Eject
05	AE-25-1000	A-16434-2	Bazaar Eject
06	20-10197	-----	Lock Magnet
07	AE-23-800	B-10686-1	*Knocker
08	20-10179	A-20839	Ramp Magnet Coil
09	AE-26-1500	A-19963-1	Trough Eject
10	AE-27-1200	B-9362-L-3	Left Slingshot
11	AE-27-1200	B-9362-L-3	Right Slingshot
12	AE-26-1200	A-9415-2	Left Jet Bumper
13	AE-26-1200	A-9415-2	Right Jet Bumper
14	AE-26-1200	A-9415-2	Bottom Jet Bumper
15	AE-27-1200	B-9362-L-3	Left Kicker
16	24-8704	A-17983 (2)	Left Eject Flasher
	24-8802	-----	*Insert Flasher
17	24-8704	A-17983 (2)	Inlane Flasher
18	24-8802	B-17802	Final Battle Flasher
19	24-8802	A-17802	Left Loop Flasher
20	24-8704	A-17983	Bazaar Flasher
21	AE-30-2000	A-20626	Ramp Diverter
22	24-8802	A-17802	Rub Lamp Flasher
23	24-8802	A-17802	Magic Lamp Flasher
24	24-8802	A-17802	Right Loop Flasher
25	24-8802	A-17802	Start Tale Flasher
	24-8802	-----	*Insert Flasher
26	24-8802	A-17802	Jet Flasher
	24-8802	-----	*Insert Flasher
27	24-8802	A-17802	Top Loop Flasher
	24-8802	-----	*Insert Flasher
28	24-8802	A-17802	Ramp Flasher

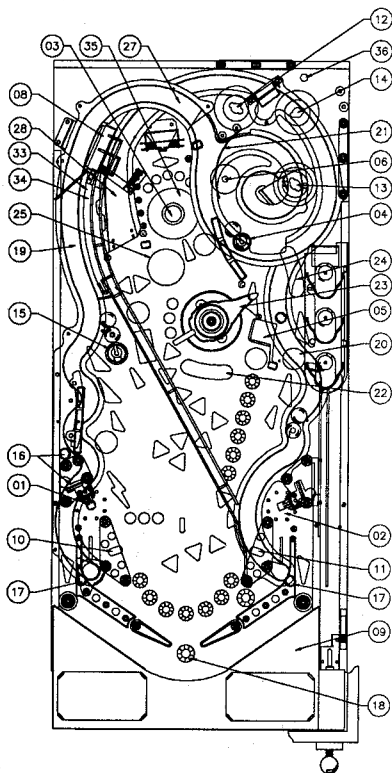

Flippers

Item No.	Coil/Flasher Number	Assembly Number	Description
29-30	FL-11629	A-14876-R-3	Lower Right Flipper
31-32	FL-11629	A-15849-L-2	Lower Left Flipper
33	FL-11753	A-20642	Left Diverter Power
34			Left Diverter Hold
35	20-10197	A-20644	Vanish Magnet
36	AE-27-1200	A-17932-1	Loop Post Diverter

General Illumination

Item No.	Bulb Number	Description
01	24-6549	*Illumination String 1
02	24-6549	*Illumination String 2
03	24-6549	*Illumination String 3
04	24-8768	*Illumination String 4
05	24-8768	*Illumination String 5

24-6549 = #44 BULB
 24-8704 = #89 BULB
 24-8768 = #555 BULB
 24-8802 = #906 BULB

*NOT SHOWN

UPPER PLAYFIELD PARTS LIST

Item No.	Part Number	Description	Not Shown: Part Number	Description
1	A-17730	Ball Shooter w/ Silver Knob	03-9488-1	*Full Playfield Mylar
2	A-20842	Shooter Lane Switch & Brlt.	03-9488-2	Jet Bumper Area Mylar
3	20-9691 03-8633	Level Mount	03-9488-3 03-9488-4	Drop Area Mylar (2) Drop Area Mylar (2)
4	A-14876-R-3 20-10110-5	Flipper Coil Assembly Flipper Shaft & White Bat	12-7210 20-6500	Rebound Wires **Steel Balls (6)
5	A-20903	Rollover Button Assembly	31-1357-50047	Backglass Translight
6	A-20878-1	Flipper Guide-Right	36-50047	Screened Hardcoat Playfield
7	A-20694	Guide Assembly		
8	B-9362-L-3	Coil & Bracket Assembly		
9	A-20877-1	Scimitar Plastic		
10	A-20627	Skill Ramp		
11	A-20693	Spike Assembly		
12	A-20695-1	Bracket & Opto Assembly		
13	04-10337	Welded Sword Assembly		
14	A-18530-6	Yellow Standup Target		
15	A-18017-6	Yellow Standup Mini Target		
16	A-20691	Loop Sub-Assembly		
17	A-16434-2	Kicker Assembly		
18	A-20636	Spinning Lamp Assembly		
19	A-20692	Skill Shot Assembly		
20	A-20499-2	Red Standup Target		
21	B-9362-L-3	Coil & Bracket Assembly		
22	A-20846-9	Red Standup Target		
23	A-20626	Swirl Ramp		
24	A-18530-6	Yellow Standup Target		
25	A-20643	Ball Guide Diverter		
26	B-9414-7 B-12030-2 A-9415-2	Jet Bumper Assembly Switch Assembly Coil Assembly		
27	A-17932-1	Disappearing Post Assembly		
28	A-20798	Back Panel		
29	A-20839	Magnet Diverter Unit		
30	A-20638	Genie Double Target		
31	A-20642	Loop Post Diverter		
32	A-20644	Vanishing Magnet		
33	A-18017-6	Yellow Standup Mini Target		
34	A-18530-6	Yellow Standup Target		
35	A-20810	Magnet Wire Ramp		
36	B-9362-L-3	Coil & Bracket Assembly		
37	A-20628	Magnet Ramp		
38	A-20846-9	Red Standup Target		
39	A-20499-2	Red Standup Target		
40	A-20695	Bracket & Opto Assembly		
41	A-20693	Spike Assembly		
42	B-9362-L-3	Coil & Bracket Assembly		
43	A-20878-2	Flipper Guide-Left		
44	A-20903	Rollover Button Assembly		
45	A-15849-L-2 20-10110-5	Flipper Coil Assembly Flipper Shaft w/ White Bat		
46	A-13204-50047	Screened Bottom Arch		

*The *Tales of the Arabian Nights* hardcoat playfield does not require a full mylar. However, mylars can be purchased through your local Williams Distributor.

**There are four ball-in-play balls and two captive balls.

UPPER PLAYFIELD PARTS LOCATION

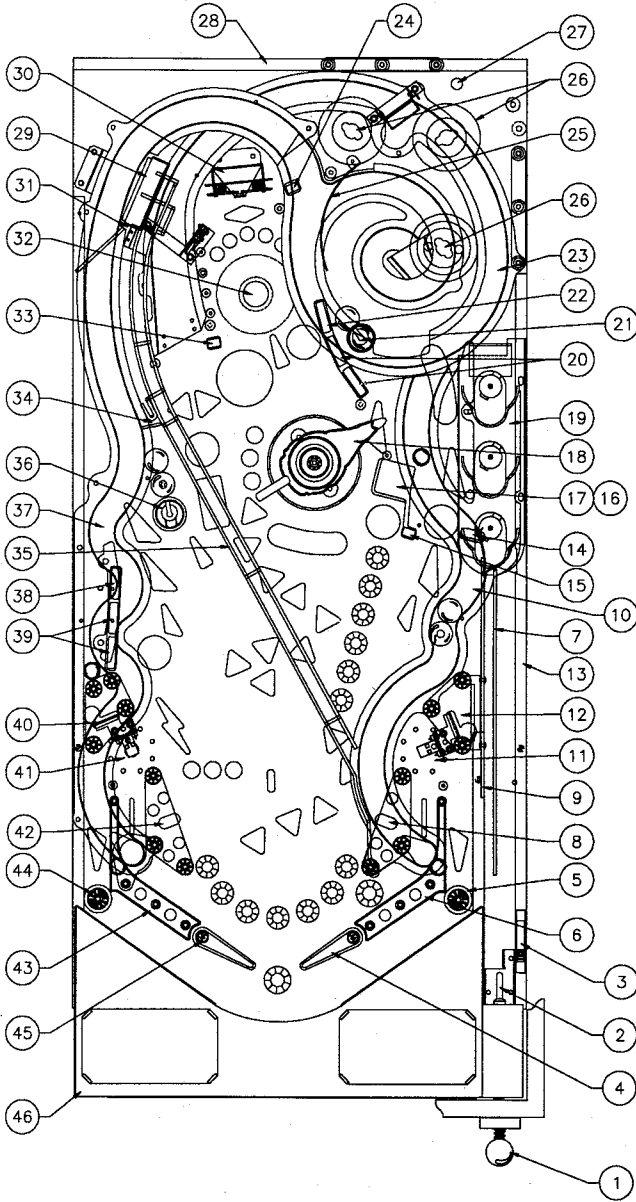

LOWER PLAYFIELD PARTS & LOCATIONS

Item	Part Number	Description
1	A-19963-1	Ball Trough Assembly
2	B-9362-L-3	Coil & Bracket Assembly (2)
	*A-17811	Kicker (Slingshot) Assy. (2)
3	A-20742	3-Lamp Board Assembly
4	A-20695-1	Bracket & Opto Board Assy.
5	A-20749	3-Lamp Board Assembly
6	A-20743	5-Lamp Board Assembly
7	A-16434-1	Kicker Assembly
8	A-20691	Loop Sub-Assembly
9	A-20636	Spinning Lamp Assembly
10	B-9362-L-3	Coil & Bracket Assembly (2)
	*B-9361-R-1	Ball Eject Assembly (2)
11	A-17749.1-2	Plfd. Slide Mechanism Assy., R.
12	A-9415-2	Jet Bumper Coil Assembly (3)
13	A-17932-1	Disappearing Post Assembly
14	A-18157	Magnet Bracket Assembly
15	A-20812	Bottom Trough Assembly
16	A-20642	Diverter Assembly
17	A-17749.1-1	Plfd. Slide Mechanism Assy., L.
18	A-20744	7-Lamp PCB Assembly
19	A-20644	Vanishing Magnet Assembly
20	A-20747	8-Lamp PCB Assembly
21	A-20746	5-Lamp PCB Assembly
22	A-14876-R-3	Flipper Assembly, Right
23	A-20745	8-Lamp PCB Assembly
24	A-15576	7-Switch Opto PCB Assy.
25	A-20693	Spike Assembly
26	A-20748	3-Lamp Board
27	A-20750	7-Lamp PCB Assembly
28	A-15849-L-2	Flipper Assembly, Left
29	01-11781	Support Bracket (2)

NOTE:
* Item located on top of
playfield.

Underside of playfield,
viewed in raised position.

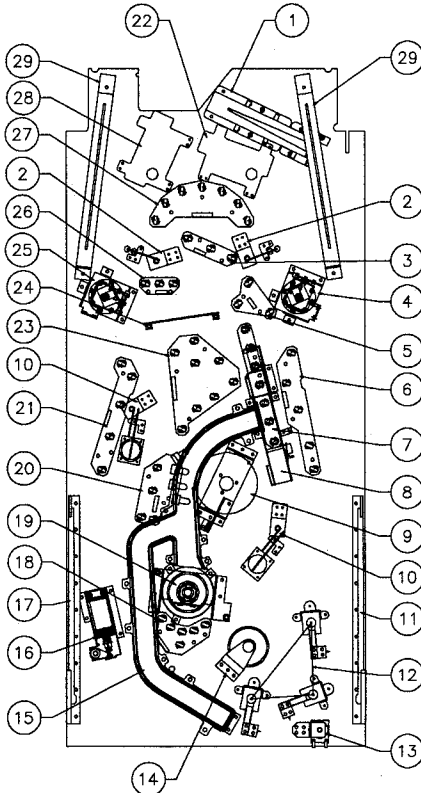

RUBBER PARTS

Item No.	Part No.	Description	Quantity
A	23-6556	Black Bumper Sleeve	6
B	23-6694-1	Black Rubber Grommet	11
C	23-6694-5	Black Rubber Ring 3/4"	1
D	23-6694-9	Black Rubber Ring 2"	4
E	23-6694-10	Black Rubber Ring 2 1/2"	2
F	23-6695	Black Flipper Ring 1 1/2"	2

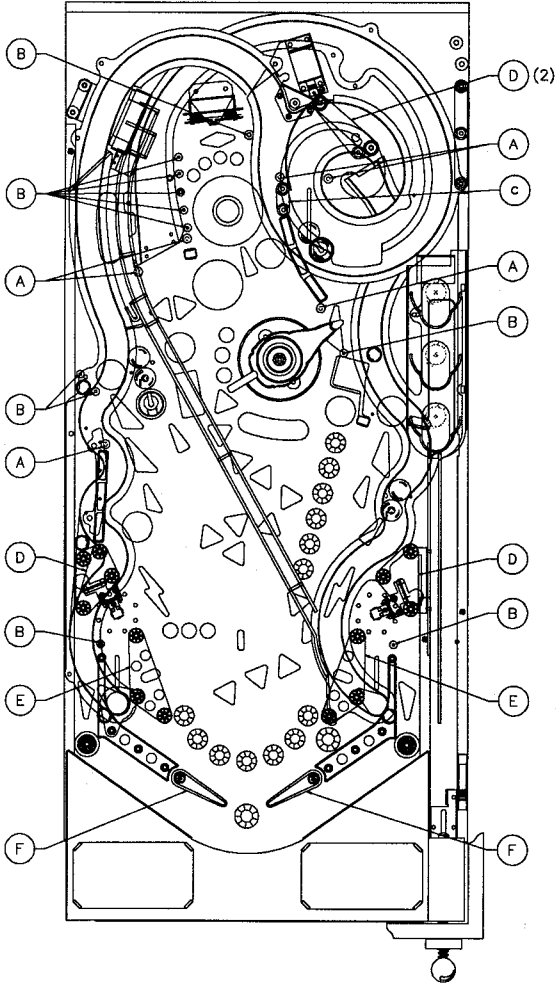

RAMPS

Item	Part Number	Description
1	A-20628	Magnet Ramp Assembly
2	A-20626	Swirl Ramp Assembly
3	A-20627	Skill Ramp Assembly
4	A-20810	Magnet Wire Ramp Assy.

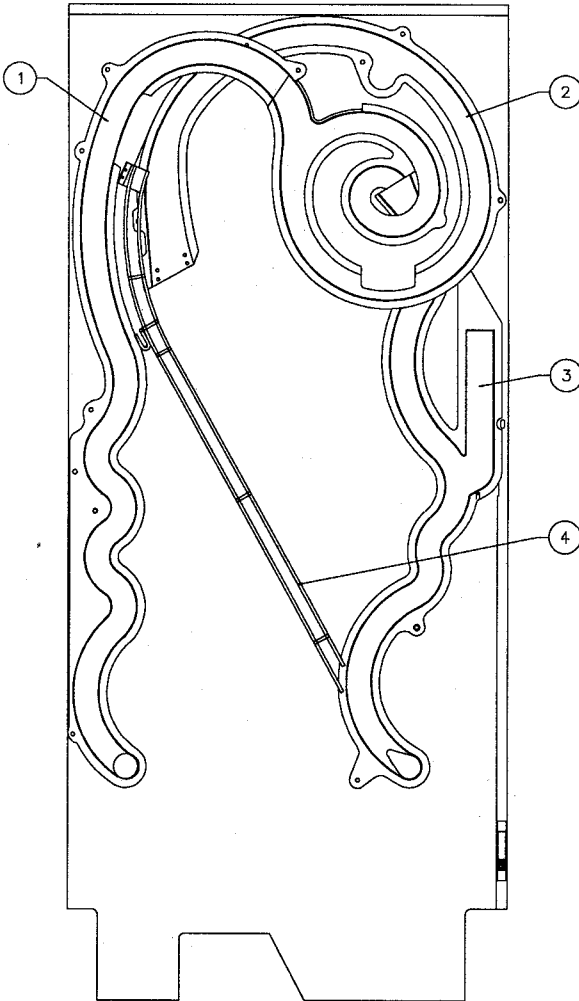

FUSE LIST

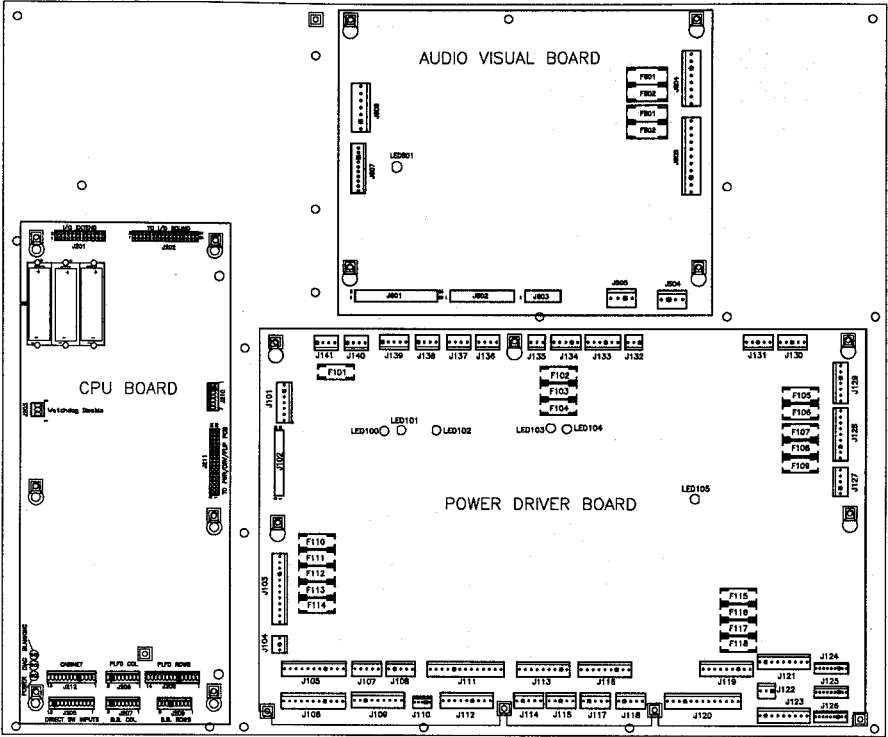

AUDIO VIDEO BOARD

Loc.	Description	Part Number	Value
F501	-25V	5731-14532-00	T2.5A, 250V
F502	+25V	5731-14532-00	T2.5A, 250V
F601	+62V	5731-14533-00	T0.25A, 250V
F602	-113V & -125V	5731-14533-00	T0.25A, 250V

CPU BOARD

There are no fuses on the CPU board.

POWER DRIVER BOARD

Loc.	Description	Part Number	Value	Loc.	Description	Part Number	Value
F101	Regulated 12V	5731-14531-00	T0.63A, 250V	F110	G.I. #5 WHT-VIO	5731-14530-00	T4.0A, 250V
F102	Solenoid #25 to #28	5731-14530-00	T4.0A, 250V	F111	G.I. #4 WHT-GRN	5731-14530-00	T4.0A, 250V
F103	Solenoid #1-#8	5731-14530-00	T4.0A, 250V	F112	G.I. #3 WHT-YEL	5731-14530-00	T4.0A, 250V
F104	Solenoid #9 to #16	5731-14530-00	T4.0A, 250V	F113	G.I. #2 WHT-ORG	5731-14530-00	T4.0A, 250V
F105	+5V Logic	5731-14530-00	T4.0A, 250V	F114	G.I. #1 WHT-BRN	5731-14530-00	T4.0A, 250V
F106	+18V Lamp Matrix	5731-14046-00	T5.0A, 250V	F115	+50V Flippers	5731-14530-00	T4.0A, 250V
F107	Flasher Secondary	5731-14530-00	T4.0A, 250V	F116	+50V Flippers	5731-14530-00	T4.0A, 250V
F108	Solenoid Secondary	5731-14529-00	T6.3A, 250V	F117	+50V Flippers	5731-14530-00	T4.0A, 250V
F109	Unregulated 12V	5731-14530-00	T4.0A, 250V	F118	+50V Flippers	5731-14530-00	T4.0A, 250V

LINE FILTER

Loc.	Part Number	Value
Foreign	5731-14530-00	T4.0A, 250V
Domestic	5731-14046-00	T5.0A, 250V

WARNINGS & NOTICES

WARNING

FOR SAFETY AND RELIABILITY, substitute parts and equipment modifications are not recommended. Use of Non-WILLIAMS parts or modifications of game circuitry, may adversely affect game play, or may cause injuries.

SUBSTITUTE PART OR EQUIPMENT MODIFICATIONS may void FCC Type Acceptance.

BECAUSE THIS GAME IS PROTECTED by Federal copyright, trademark, and patent laws, unauthorized game conversions may be illegal under Federal law.

THIS 'CONVERSION' PRINCIPLE ALSO APPLIES to unauthorized facsimiles of WILLIAMS equipment, logos, designs, publications, assemblies, and games (or game features not deemed to be public domain), whether manufactured with WILLIAMS components or not.

NOTICE

WILLIAMS, Lane-change and Multi-ball are trademarks of WILLIAMS ELECTRONICS GAMES, INC. Entire contents of this manual © 1995 WILLIAMS ELECTRONICS GAMES, INC.

WARNING

NOTE: This equipment has been tested and found to comply with the limits for a Class A digital device, pursuant to Part 15 of the FCC Rules. These limits are designed to provide reasonable protection against harmful interference when the equipment is operated in a commercial environment. This equipment generated, uses, and can radiate radio frequency energy and if not installed and used in accordance with the instruction manual, may cause harmful interference to radio communications. Operation of this equipment in a residential area is likely to cause harmful interference in which case the user will be required to correct the interference at his own expense.

RF Interference Notice

CABLE HARNESS PLACEMENTS and ground strap routing on this game have been designed to keep RF radiation and conduction within levels accepted by the FCC Rules.

TO MAINTAIN THESE LEVELS, reposition harnesses and reconnect ground straps to their original placements, if they become disconnected during maintenance.

FCC STICKER. Check the back of your game to verify that an FCC-certification sticker was attached to your game at the factory. All games that leave the WILLIAMS plant have been tested and found to comply with FCC Rules. Because the sticker is proof of this fact, legal repercussions to the owner and distributor may result, if the sticker is missing. If you receive a game, manufactured after December 1982, that has no FCC sticker, call WILLIAMS for advice or write us a note on your Game Registration Card. Be sure that the card bears your game's serial number.

© 1996 Williams Electronics Games, Inc.

For Service...
Call your authorized Williams Distributor

Williams Electronics Games, Inc.
3401 N. California Avenue
Chicago, IL 60618

CAUTION: Transport this game ONLY with the hinged backbox DOWN!