



OPERATOR'S MANUAL

VERSION 0.1 - PRELIMINARY

SUPER ALPINE RACER OPERATOR'S MANUAL



Uses Granny Animation. Copyright (C) 1999-2014 by RAD Game Tools, Inc.



Uses Bink Video. Copyright (C) 1997-2014 by RAD Game Tools, Inc.

SUPER ALPINE RACER OPERATOR'S MANUAL

Safety

OPERATION

Before operating game, read this manual. Failure to properly install and operate this game could result in malfunction or accident. Operate the game in accordance with the manual.

TRANSPORTING

The cabinet is very heavy. Because the monitor is high, the cabinet is also very top-heavy. Use appropriate care when moving or transporting cabinet. It contains fragile glass and electronic components. Avoid rough handling.

HANDLING COMPONENTS

Many components are extremely sensitive to handling, environmental and Electrostatic Discharge (ESD) events—especially the computer. Do not handle it roughly. Before servicing, call your distributor and inquire about the PC warranty. Use proper ESD procedures when servicing. Protect components from harmful environmental conditions, such as extreme temperatures, excessive moisture or other damaging effects.

DISCONNECT POWER

Always turn the power off and unplug the unit before servicing or making adjustments unless otherwise instructed. Installing or repairing components while power is on can damage the components and void the warranty.

GROUNDING

Avoid electrical shock. Do not plug in AC power until you have inspected and properly grounded the unit. Only plug into a grounded, three-wire outlet. Do not use a “cheater” plug or cut off the ground pin on the line cord.

ELECTRICAL SHOCKS

There is no isolation transformer in the cabinet. Disconnect AC power before servicing. However, be aware that lethal voltages can remain in the electronic components even when AC power is disconnected. Use extreme caution when servicing. Verify that there is a working ground connection. If the unit sustains water damage, cease using it immediately and unplug AC power.

MONITOR

The monitor contains no user serviceable parts. Do not attempt to service the monitor.

POWER SELECTOR

Before installing game, ensure the voltage on the PC and power supply are set properly. There is a 115/230 VAC selector switch that must be set for the correct voltage for your site. Verify the fluorescent lamp rating. The rating must match the line voltage at the installation site.

POWER CORD

If the power cord is damaged or lost, replace it with an identical cord as supplied by the manufacturer or an authorized service agent.

SURGE SUPPRESSOR

It is recommended that you plug your game's power cord into a surge suppressor to help protect from power surges that may damage sensitive electronic components.

SUPER ALPINE RACER OPERATOR'S MANUAL

Service Manual

CONNECTORS

When servicing machine, ensure all connectors mate properly. If connectors do not slip in easily, do not force them. Connectors are often keyed and only connect one way. Check for correct orientation.

COMPUTER

The computer contains sensitive components, including a hard drive. Do not handle it roughly. Call your distributor before servicing its internal components. Ask about warranty information as it relates to the PC.

Do not turn the PC power switch on or off. It should remain permanently in the ON position.

Cycle AC power on or off with the cabinet power switch.

A dongle has been inserted into one of the USB ports. This is required for game play.

Do not remove the dongle except for troubleshooting purposes.

FLUORESCENT LAMP

A dropped fluorescent lamp tube may break and implode. Shattered glass from the implosion can travel long distances and cause bodily injury. Use proper procedures when handling broken materials, as these items can contain **hazardous material such as mercury or lead.**

HAZARD TO EPILEPTICS

A small portion of the population has an epileptic condition that may cause seizures. Affected persons experience seizure while watching some television pictures or playing certain video games. People who have not had seizures may still have an undetected epileptic condition. If anyone in your family has experienced epilepsy symptoms (seizures or loss of awareness), consult your physical before using video games. While children play video games, a parent should observe. Be alert to the following symptoms: dizziness, altered vision, eye or muscle twitching, involuntary movements, loss of awareness, disorientation or convulsions. If you or your child experiences these symptoms, discontinue use immediately and consult your physician.

MANUAL

Keep this manual available and ready for use. If the game fails to function properly, turn off the machine and unplug the AC line cord. Contact your local distributor. Your warranty, when applicable, lasts 60 days from your purchase date. You may not reproduce this document or any of its contents without written authorization from Raw Thrills, Inc. .

SPECIFICATIONS

For reasons such as performance, this product's specifications may change without notice. Federal patent, copyright and other intellectual property laws protect the content, devices and design of the game and its equipment.

SUPER ALPINE RACER OPERATOR'S MANUAL

Product Specifications

Electrical Power

United States, International and Japan
Inrush AC Current: 7 Amps
Operating AC Current: 5 Amps
Voltage: 100/115/240 50/60Hz VAC

Shipping Dimensions

Main Cabinet: 42"x 37"x 86" (1.06m x 1.19m x 2.18m)
Pedestal: 42"x 38" x 55" (1.06m x 97m x 1.40m)
Weight: 650 lbs (294.84 kg)

Temperature

50° F to 104° F

(10° C to 40° C)

Humidity

Must not exceed 95% relative humidity

Dimensions

Height: 102.4" (2.60 meters)

Width: 35.3" (.90 meters)

Depth: 79.3" (2.01 meters)



Electrical Safety Notice: This product is designed for indoor use only. For continued electrical safety, replace fuse with fuse of equivalent rating. Use only properly grounded AC service outlet and correct line cord. Do not by-pass the ground terminal or use cheater plug. Doing so would create an electrical hazard and also affect the games safety and reliability due to increased Electro Static Discharge susceptibility. Do not install game near source of water jet or condensation.



AUTHORIZATION TO MARK

This authorizes the application of the Certification Mark(s) shown below to the models described in the Product(s) Covered section when made in accordance with the conditions set forth in the Certification Agreement and Listing Report. This authorization also applies to multiple listee model(s) identified on the correlation page of the Listing Report.

This document is the property of Intertek Testing Services and is not transferable. The certification mark(s) may be applied only at the location of the Party Authorized To Apply Mark.

Applicant: Raw Thrills Inc.
Address: 5441 Fargo Avenue
 Skokie, IL 60077
Country: USA
Contact: Mr. Richmond Catalan
Phone: (847) 679-8373 ext. 28
FAX: (847) 679-8538
Email: rich@rawthrills.com

Manufacturer: Partec Inc.
Address: 9301 W. Belmont Avenue
 Franklin Park, IL 60131
Country: USA
Contact: Mr. Brian Poklacki
Phone: (847) 678-9520
FAX: (847) 678-1940
Email: poklacki@partec-inc.com

Party Authorized To Apply Mark: Same as Manufacturer
Report Issuing Office: Chicago, IL

Catherine Dwyer

Control Number: 3174723

Authorized by: _____
 for Thomas J. Patterson, Certification Manager



This document supersedes all previous Authorizations to Mark for the noted Report Number.

This Authorization to Mark is for the exclusive use of Intertek's Client and is provided pursuant to the Certification agreement between Intertek and its Client. Intertek's responsibility and liability are limited to the terms and conditions of the agreement. Intertek assumes no liability to any party, other than to the Client in accordance with the agreement, for any loss, expense or damage occasioned by the use of this Authorization to Mark. Only the Client is authorized to permit copying or distribution of this Authorization to Mark and then only in its entirety. Use of Intertek's Certification mark is restricted to the conditions laid out in the agreement and in this Authorization to Mark. Any further use of the Intertek name for the sale or advertisement of the tested material, product or service must first be approved in writing by Intertek. Initial Factory Assessments and Follow up Services are for the purpose of assuring appropriate usage of the Certification mark in accordance with the agreement, they are not for the purposes of production quality control and do not relieve the Client of their obligations in this respect.

Intertek Testing Services NA Inc.
 545 East Algonquin Road, Arlington Heights, IL 60005
 Telephone 800-345-3851 or 847-439-5667 Fax 312-283-1672

Standard(s):	Standard for Safety for Amusement and Gaming Machines (UL 22, Issued: 2008/05/30 Ed: 6 Rev: 2013/09/25) Household and Similar Electrical Appliances – Safety – Part 2-82: Particular Requirements for Amusement Machines and Personal Service Machines (CSA E60335-2-82:13 Issued: 2013/01/03), used in conjunction with: Household and Similar Electrical Appliances – Safety – Part 1: General Requirements (CSA-E60335-1/4E Issued: 2003/04/01 (R2007))
Product:	Arcade Gaming System
Models:	Alpine racer

SUPER ALPINE RACER OPERATOR'S MANUAL

Setup and Installation

Unpack Materials

1. Place the shipping crates on a flat, stable surface.
2. Cut the banding straps and remove the cardboard lids.
3. Lift off the large cardboard containers surrounding the front pedestal and monitor assemblies and remove any shipping cleats.
4. Remove the coin door key from the coin return slot.
5. Open the top coin door.
6. Locate the keys for the back door and the cash box door.
7. Open the cash box door and remove the cash box.
8. Check for shipping damage to the following:
 - Alpine Racer player accessible areas such as the ski platform and dash.
 - Marquee and monitor
 - Cabinet decals
9. Check the AC line cord for visible signs of damage.

Pay particular attention to the plug and line cord insulation.

Mechanical Setup

- **READ THIS DOCUMENT AND BECOME FAMILIAR WITH THE SETUP REQUIREMENTS BEFORE YOU BEGIN WITH INSTALLATION!**

IMPORTANT SAFETY NOTES:

- Game Setup requires at minimum 2 individuals able to lift 50 pounds or more for safety.
- Make sure that the work area suitable for installation and setup. It must be well lit, have a level surface and free of debris.
- Adequate clearance is required around the unit for use of ladders. Adequate clearance is required above the unit for bringing the unit to a full upright and operating position.
- Do not lean on the game during installation. Certain portions of the game may shift or move.
- Keep your hands and fingers clear of moving parts at all times.
- Exercise caution at all times throughout the installation process.
- Make sure that all fasteners are installed where indicated. Use the correct tools and fasteners.
- Make sure each assembly is fully fastened and secure after each step.

SUPER ALPINE RACER OPERATOR'S MANUAL

STEP 1: MARQUEE INSTALLATION PROCEDURE

Locate the marquee assembly and the following hardware: (4) black tamper proof Torx machine screws, ¼-20 thread, ½" length and (4) ¼" black split-lock washers.

With the use of a ladder on a stable floor, lift the marquee into position as shown and secure the 4 screws and washers using a T-27 Torx tool.

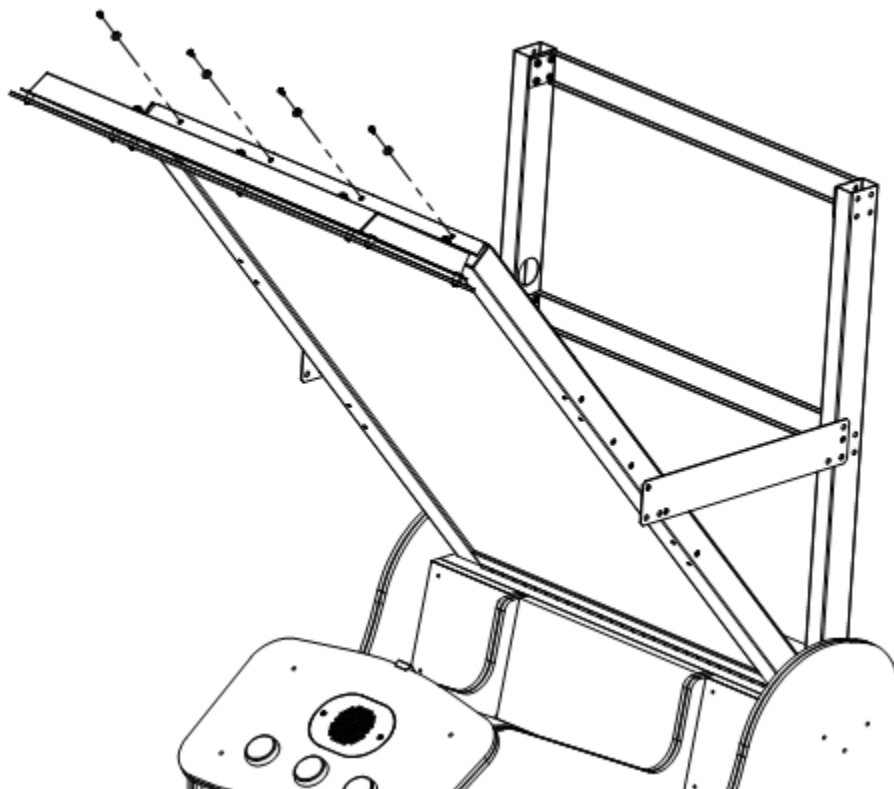

SUPER ALPINE RACER OPERATOR'S MANUAL

STEP 2: MONITOR INSTALLATION PROCEDURE

WARNING: MONITOR IS HEAVY AND MOUNTED ON A HINGE. BE CAREFUL NOT TO PLACE FINGERS IN A PLACE WHERE THEY MAY BECOME PINCHED OR CRUSHED.

1: Monitor safety suspension chains have been installed to help support the monitor weight for this process. Carefully use a T-27 tool to remove (2) sets of short bolts and washers holding the monitor mounting plates on each side of the monitor. (SEE ARROW A)

Once the bolts have been removed, the monitor should be gently guided into its operating position. BE CAREFUL NOT TO PLACE FINGERS IN A PLACE WHERE THEY MAY BECOME PINCHED OR CRUSHED.

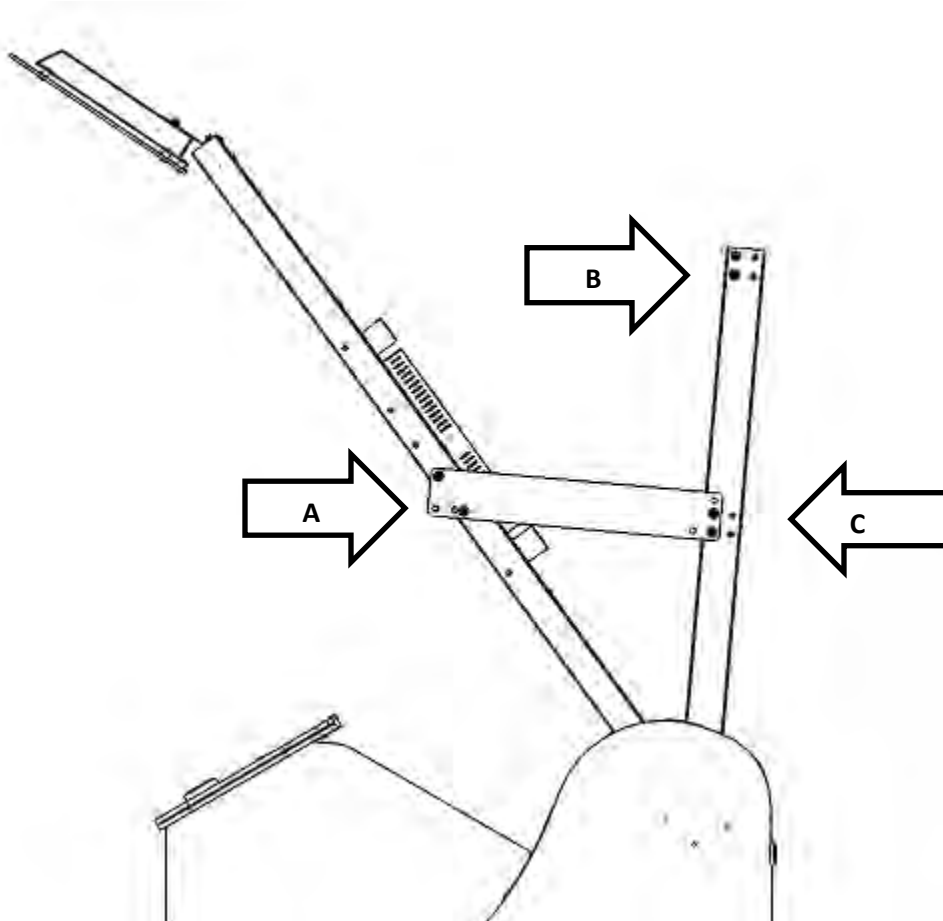

After the monitor has been safely rotated back to its operating position, remove (4) sets of long bolts from each side, (2) holding the mounting plates in place (SEE ARROW B) and (2) more near the top side of mounting tubes and toward the front of cabinet (SEE ARROW C). DO NOT REMOVE THE SCREWS AT THE BACK SIDE OF THE TUBES.

SUPER ALPINE RACER OPERATOR'S MANUAL

NOTE: It is recommended to keep all monitor mounting screws “finger-tight” until all (12) screws have been installed, for alignment purposes. Once aligned, all screws should be securely tightened such that the split -lock washers have been flattened.

2: Reinstall monitor mounting brackets as shown in the below figure. Using T-27 tool, install (4) sets of long screws through the side plates and tubes first(SEE ARROW D), then install remaining (2) sets of short screws into matching holes on monitor sides(SEE ARROW E).

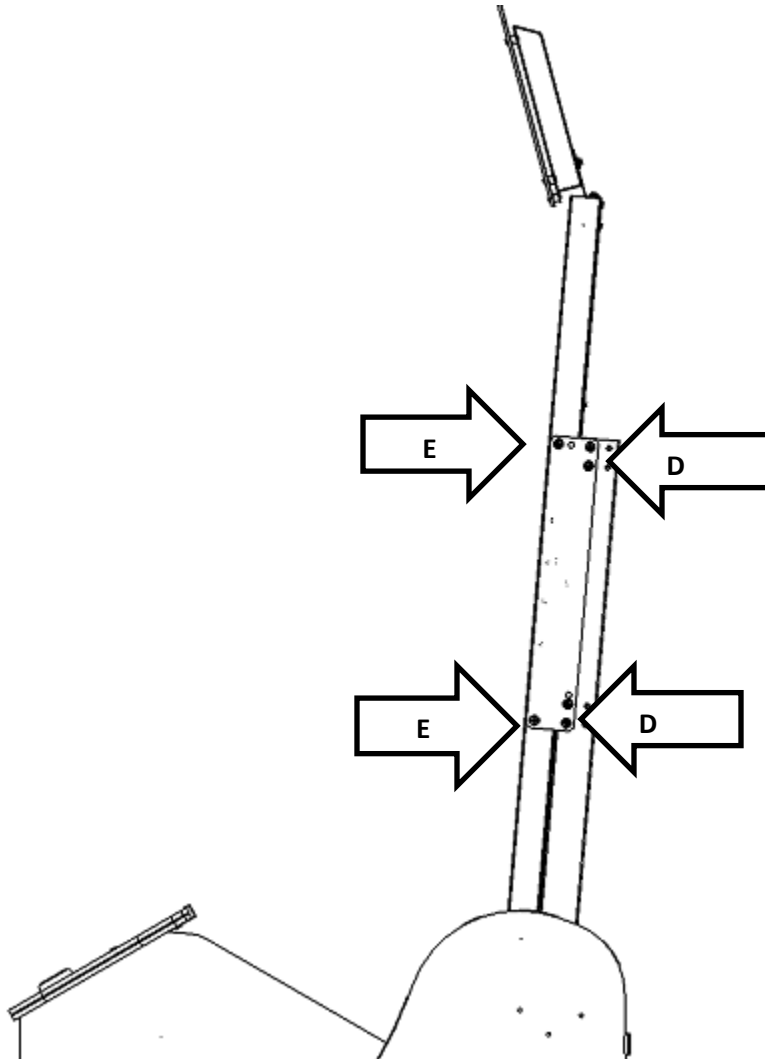

3: Retrieve marquee harness at top right when viewing cabinet from back side and guide the harness down the right tube. Connect the 3 position mating connector to the marquee harness at the back of the game- near the I/O pcb.

4: Retrieve line cord from the right tube access hole when viewing cabinet from rear and make connection to monitor power port. Retrieve video cable from the left tube access hole when viewing cabinet from rear and make connection to monitor video port.

SUPER ALPINE RACER OPERATOR'S MANUAL

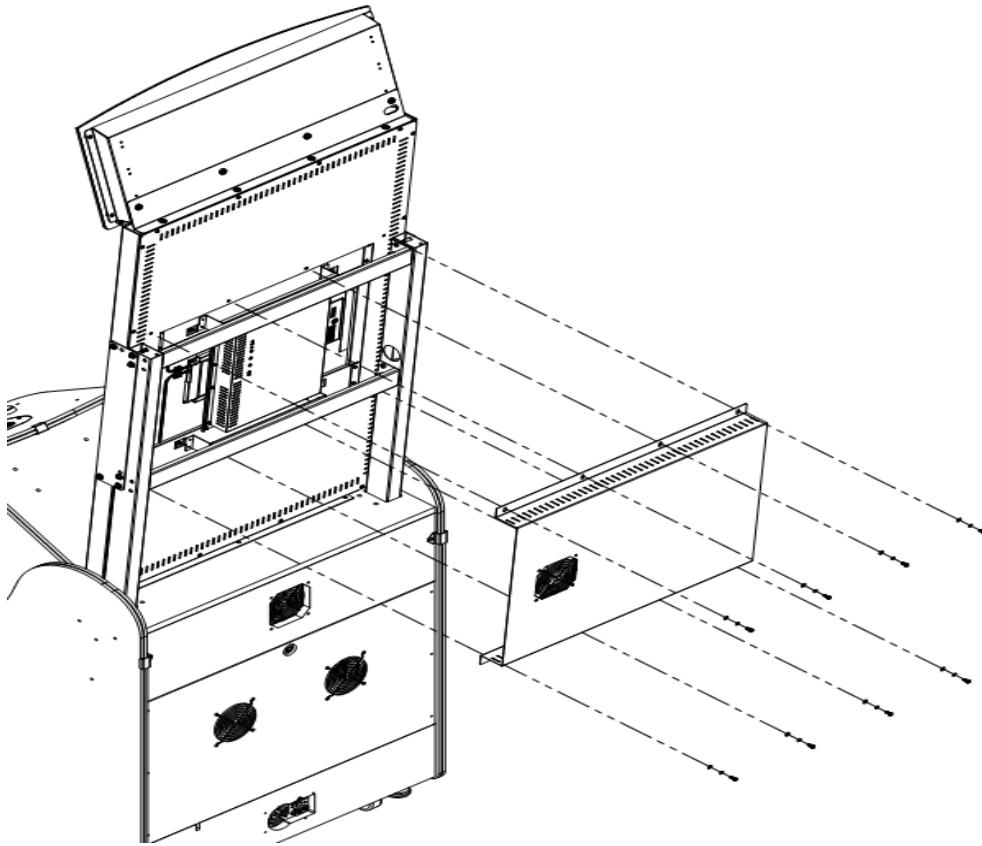

5: Locate the LCD cover plate assembly and the following hardware: (8) black tamper proof Torx machine screws, 10-32 thread, ½" length and (8) #10 black split-lock washers and (8) #10 black flat washers.

6: Retrieve fan harness from the left tube access hole when viewing cabinet from rear and make secure connection to exhaust fan on cover plate. Also, make sure the monitor line cord and video cable are not an obstruction to proper installation of cover plate.

7: Using T-25 tool, install cover plate assembly to the rear of the monitor box with the supplied hardware as shown in figure above (**NOTE: PROPER ORIENTATION OF COVER PLATE AND ATTACHED FAN IS CRITICAL TO LIFESPAN OF MONITOR**).

SUPER ALPINE RACER OPERATOR'S MANUAL

STEP 3: PEDESTAL INSTALLATION PROCEDURE

NOTE: It is recommended to keep all pedestal mounting screws “finger-tight” until all screws have been installed for alignment and leveling purposes. Once aligned, all screws should be securely tightened such that the split-lock washers have been flattened.

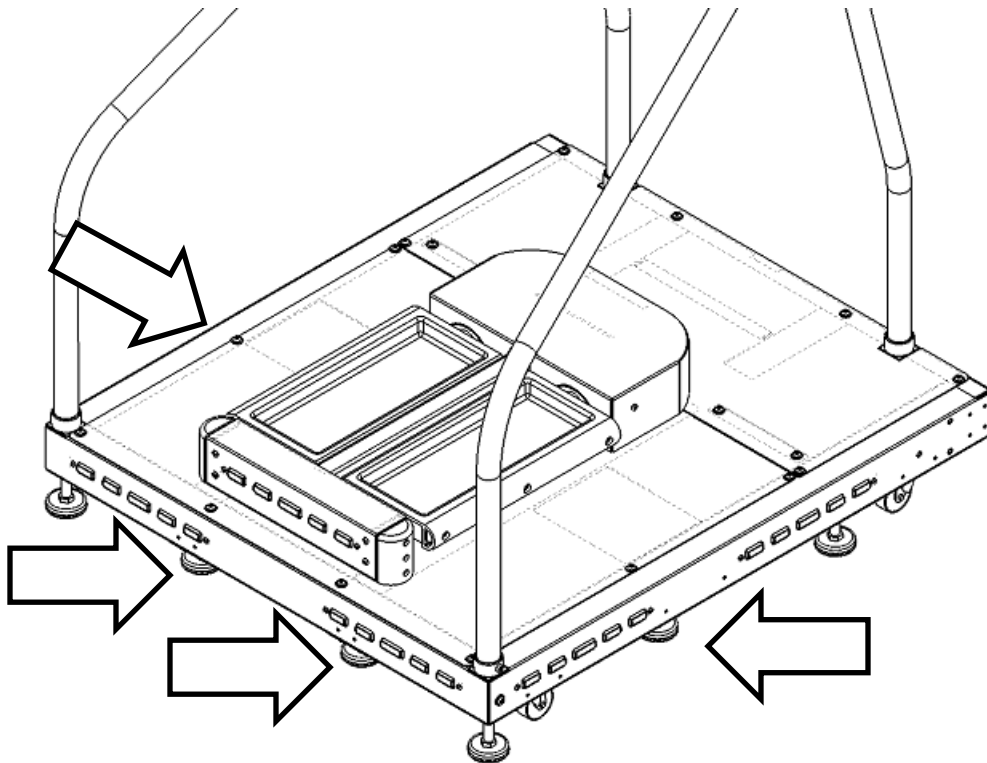

1: To ease the leveling process of the pedestal, the middle leg levelers (SEE ARROWS) should be raised such that only the (4) “corner” leg levelers are in contact with the floor as shown in the above figure. 5/8” and 3/4” open-end wrenches (for the locking hex nut and leg leveler nut, respectively) will be needed to adjust pedestal leg levelers as brackets are being installed.

SUPER ALPINE RACER OPERATOR'S MANUAL

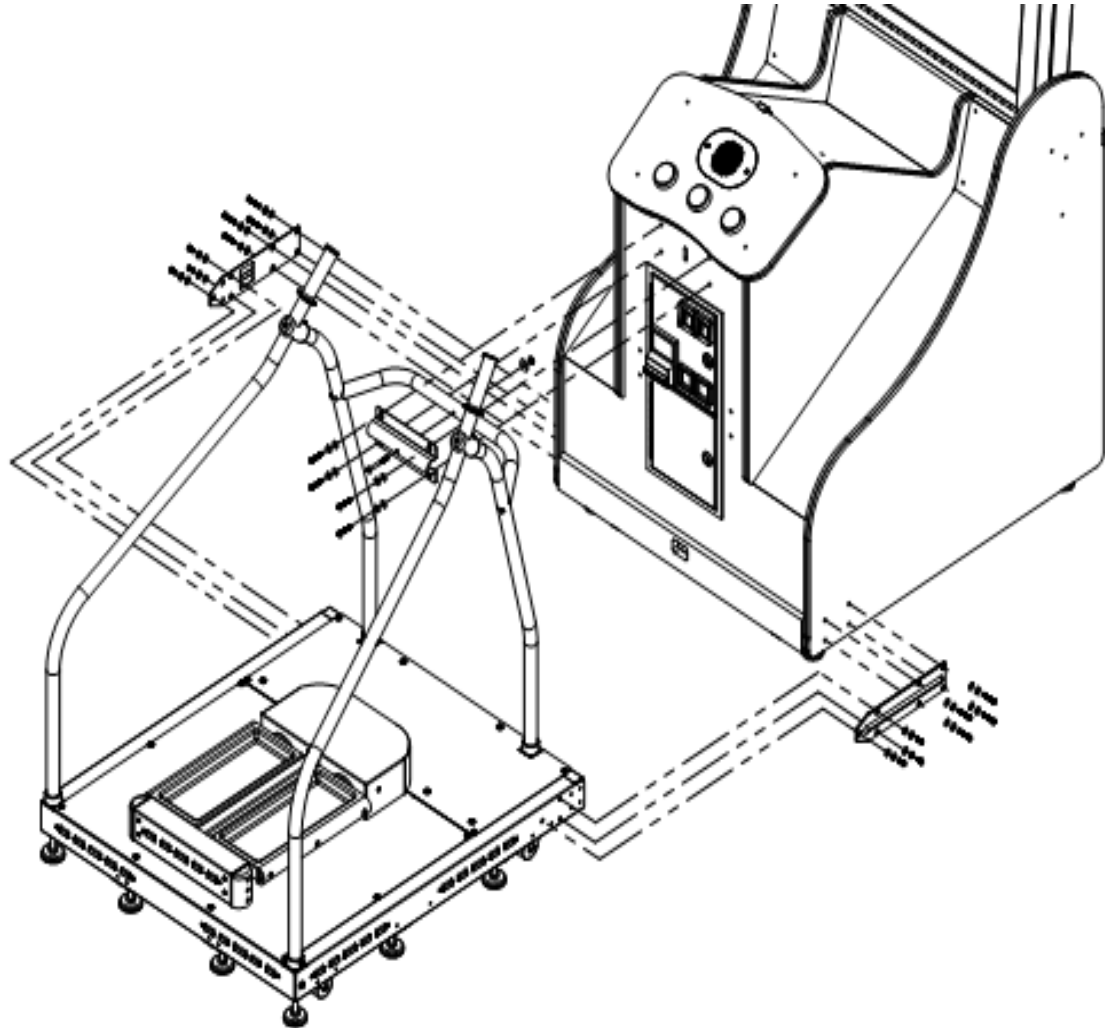

2: Locate (2) platform to cabinet connecting brackets and the following hardware: (8) black tamper proof Torx machine screws, $\frac{1}{4}$ -20 thread, $1\text{-}\frac{1}{4}$ " length and (8) $\frac{1}{4}$ " black split-lock washers and (8) $\frac{1}{4}$ " black flat washers. Using a T-27 tool, attach these brackets to each side of cabinet as shown in figure above.

3: Move pedestal in place between these brackets and connect harness from cabinet to panel mount connector on pedestal. Install (6) black tamper proof Torx machine screws, $\frac{1}{4}$ -20 thread, $\frac{3}{8}$ " length and (6) $\frac{1}{4}$ " black split-lock washers and (6) $\frac{1}{4}$ " black flat washers through brackets and into PEM nuts on pedestal sides using T-27 tool.

4: Locate (1) pole to cabinet bracket and the following hardware: (4) black tamper proof Torx machine screws, $\frac{1}{4}$ -20 thread, $1\text{-}\frac{1}{4}$ " length and (4) $\frac{1}{4}$ " black split-lock washers and (4) $\frac{1}{4}$ " black flat washers. Using

SUPER ALPINE RACER OPERATOR'S MANUAL

T-27 tool, install bracket over cross tube and attach to front panel of cabinet through slots into T-nuts inside cabinet.

5: Locate (1) black tamper proof Torx machine screw, ¼-20 thread, 2-½" length and (1) ¼" zinc fender washer and (1) ¼-20" keps lock nut. Open top coin door and attach the washer and keps nut on the interior of the cabinet to the long machine screw after it passes through the bracket, the cross tube, and front panel. Use T-27 Tool and 7/16" socket/wrench for tightening.

6: Cabinet should have been leveled as the hardware was being installed and now all leg levelers can be lowered to the floor and all hardware securely tightened such that the split-lock washers have been flattened.

Check Electrical Settings

1. Verify the proper voltage in the nearest AC outlet.
2. Verify the AC outlet ground connection is present and working.
3. Refer any issues with the AC outlet and service to qualified person. Do not attempt to service or modify electrical outlets or line cords.

Game Power Up

1. Plug in line cord to AC outlet.
2. Turn the power switch to ON.
3. Check that no component is excessively hot or emitting foul odors.
If not, turn off AC power and disconnect line cord. Refer to the diagnostic section of this manual.
4. Once software loads, you will be asked to calibrate the controls.
If not, enter the service menu by pressing the TEST button located on the bracket inside the top coin door.
5. See multiplayer networking/linking information on page 24-25.

SUPER ALPINE RACER OPERATOR'S MANUAL

Diagnostics and Adjustments

The Service Button Panel has four buttons, three of which can navigate the menu system.

But it is easiest to navigate with a Start, Left / Right Arrow buttons

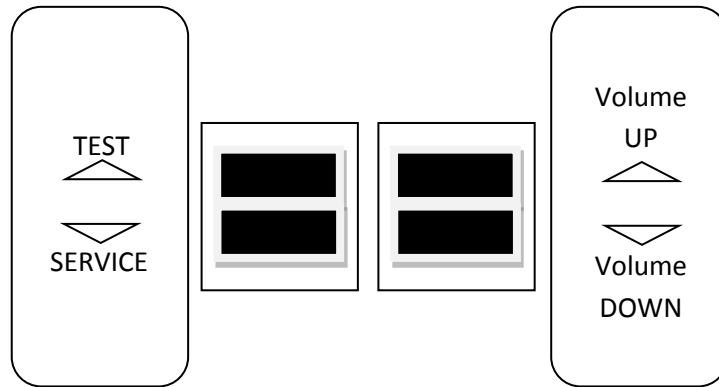

- Service Panel TEST enters diagnostic system.
- Either Service Panel TEST button or Start button selects the highlighted option.
- Service Panel VOL DOWN button or right arrow button moves down through menu or setting choices.
- Service Panel VOL UP button or pressing left arrow moves up through menu or setting choices.
- Highlight and select Exit to return to previous screen.

An on-screen message acknowledges changes or when you exit a selection without making a change.

At the bottom of each screen there is a brief description of the menu option's function. A complete description is available here for all menu functions.

Instructions for completing your first calibration start on the next page.

SUPER ALPINE RACER OPERATOR'S MANUAL

INITIAL GAME SETUP

GAME CONTROLS CALIBRATION

1. If the calibration screen is not visible, press the TEST button to enter the Diagnostic System.
2. From the Main Menu, use Volume +/- to highlight Calibration.
3. Press a Start button to enter calibration.

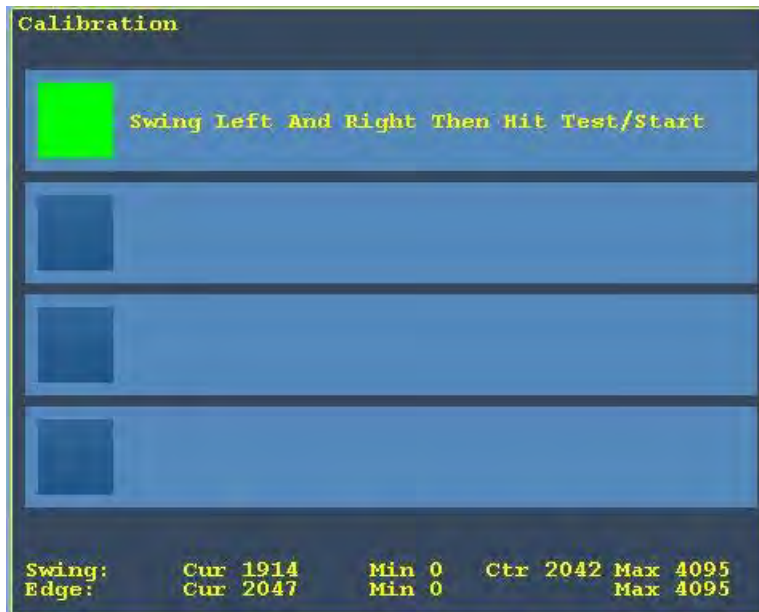

4. Follow on-screen instructions. Re-try if calibration data is not valid.
5. Game will proceed to Location and Venue Name entry.
6. Enter information to be displayed when player scans the QR Code.
7. Game will enter Attract Mode. All game settings will be default values if no changes are made at this time.

GAME CONTROLS AND INTERFACE INSPECTION

Other Tests

See the Diagnostic Section for further information.

1. Enter the Switch Test menu and verify all switches function.
2. Enter the Screen Test menu and verify that video is acceptable.
3. Enter the Sound Test menu and verify the audio works and is not distorted.
4. Enter the Coin Meter Test menu and verify the operation of the coin meter.
5. Enter the Cabinet Lamps Test menu and verify that all cabinet lights work correctly.
6. Enter the Watchdog Test menu, which reboots the game.
7. Upon a successful reboot, you are ready to make adjustments to pricing, volume and other functions found in the Adjustments, Audits and Diagnostics section.

SUPER ALPINE RACER OPERATOR'S MANUAL

Adjustments, Audits and Diagnostics

Main Menu

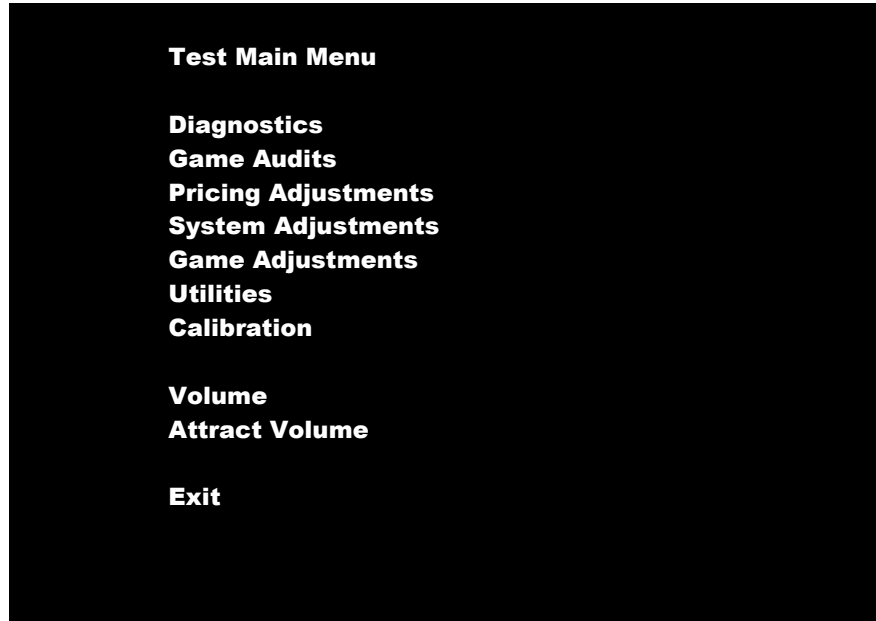

Menu Option	Description
Diagnostics	Verify all game functionality. Allows activation of all inputs and outputs, including linking and watchdog test.
Game Audits	View game earnings and gameplay statistics.
Pricing Adjustments	Setting for coinage unit, denomination and game pricing.
System Adjustments	System related changes such as networking, language, attract volume, Wheel power, blower and shaker force etc.
Game Adjustments	Game specific adjustments such as difficulty, bonus time, game entry.
Utilities	Clear Credits, Audits and reset player/game statistics. Check system software errors and download data to USB external storage device.
Calibration	Calibrate controls for maximum player control and game experience.

SUPER ALPINE RACER OPERATOR'S MANUAL

Volume	Set volume during game only. Attract volume is adjusted independently.
Attract Volume	Set attract/ standby mode volume only.

Main Menu
Diagnostics
Switch Test

For troubleshooting purposes, this menu gives you visual feedback of all switch functions.



NOTE: PRESS AND HOLD START BUTTON OR TEST BUTTON TO TOGGLE SKI BRAKE ON/OFF.

SUPER ALPINE RACER OPERATOR'S MANUAL

Main Menu
Diagnostics
Sound Test

For troubleshooting purposes, this menu gives game sound feedback.

Menu Option	Description
Change Music	Change current music.
Change Effect	Change sound current sound effect.
Play 100Hz or 1kHz	Play low and high frequency to stimulate bass or full range speaker response.
Pan Center, Left, Right	Isolate sound into separate channel to verify correct speaker function.

Main Menu
Diagnostics
Monitor Test

For troubleshooting purposes, this menu allows the diagnosis of the display to detect color or linearity issues.

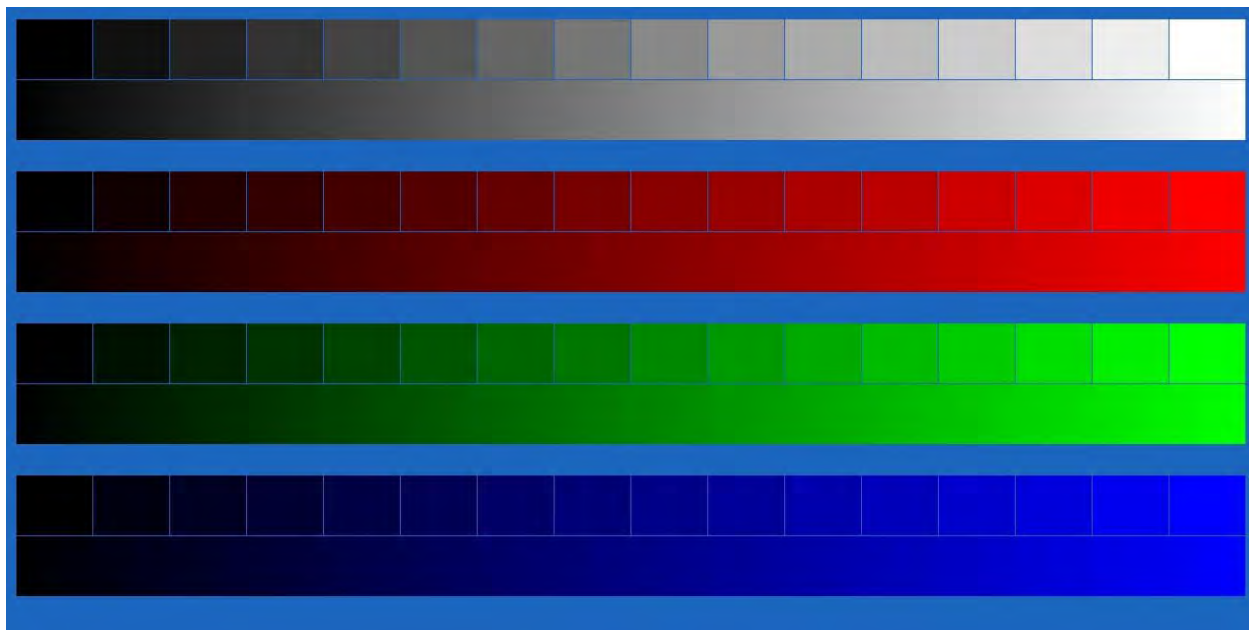

SUPER ALPINE RACER OPERATOR'S MANUAL

Main Menu
Diagnostics
Light Test

For troubleshooting purposes, this menu allows the diagnosis of the game's controlled lighting features.

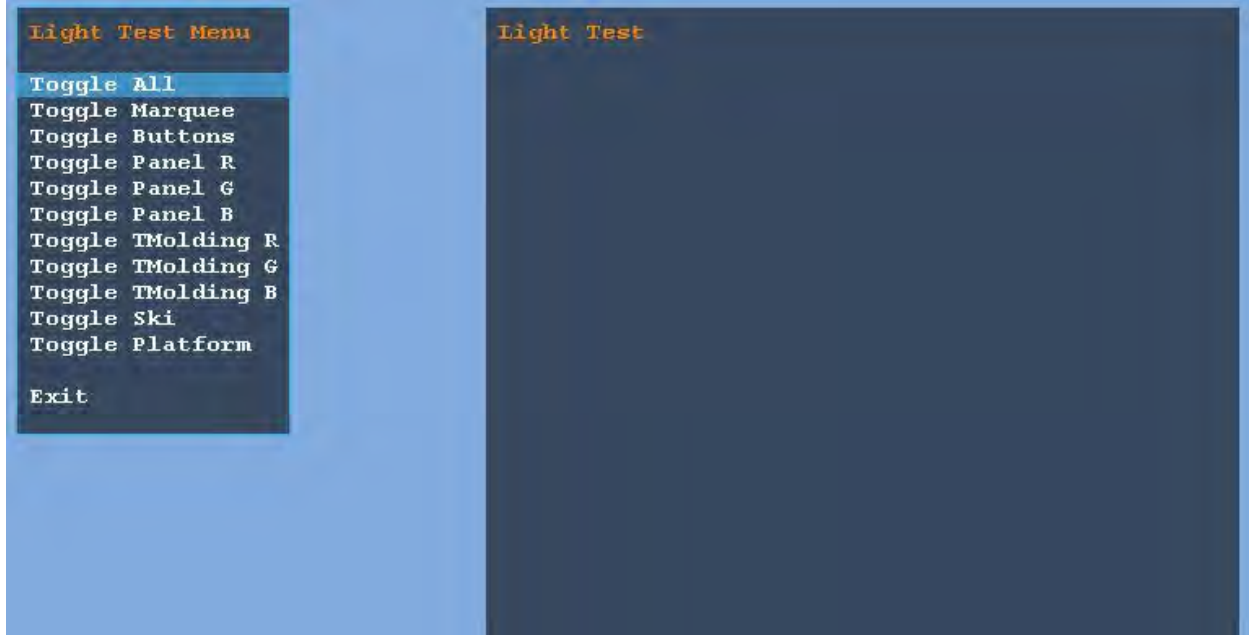

Main Menu
Diagnostics
Coin Meter Test

For troubleshooting purposes, this menu allows the activation of coin meter. Press Start or Test to advance coin meter.

Main Menu
Diagnostics
Watchdog Test

This menu allows the activation of the watchdog/reset system. Press Start or Test to start test. The game's watchdog system allows the machine to recover automatically from a crash or a failure to boot. The watchdog system is always active.

SUPER ALPINE RACER OPERATOR'S MANUAL

Main Menu
Diagnostics
Link System Test

This allows the operator to view and reset the link status of two or more games connected to a single network. Linking three or more games requires a network hub and must be purchased separately.

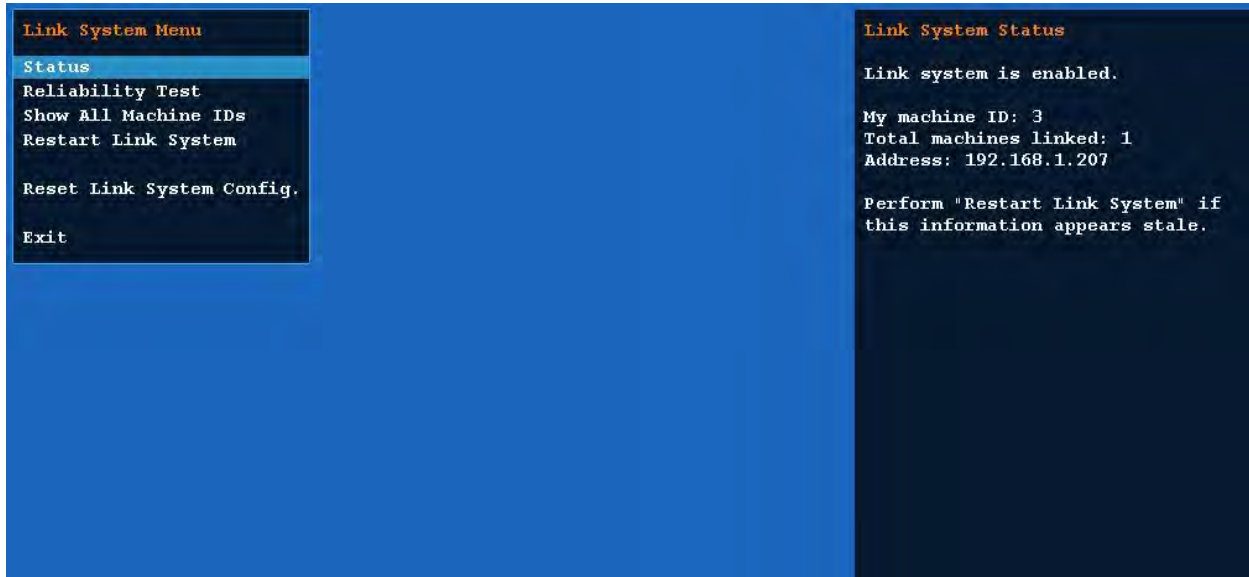

Main Menu
Diagnostics
Blower Test

Test the blower function at different speeds. This can also be used to determine desired blower intensity.

SUPER ALPINE RACER OPERATOR'S MANUAL

Main Menu
Game Audits
General Audits 1

View general game statistics.

Audits Menu General 1 General 2 Courses Course Wins Places Skiers Gameplay Exit	General Audits Time Since Boot 3:28.75 Time Game On 8:34:5.82 Time Game Played 6:06:13.40 Time Per Game 2:13.17 Games Played 165 Games Started 131 Games Continued 9 Games Timed Out 0 Free Games 20 12.12% Link Games 0 0.00% Boot Ups 10 Test Mode Entries 2 Maintenance Reboots 0 Watchdog Resets 0 No I/O Board Init 0 Unfinished Games 6 I/O Lost 1 I/O Recovered 1 Dongle Lost 0 Dongle Recovered 0 Prefs Damaged 0 Prefs Repaired 0
--	---

Main Menu
Game Audits
General Audits 2

Audits Menu General 1 General 2 Courses Course Wins Places Skiers Gameplay Exit	General Audits First Person Time 0:00.00 Dynamic Cam Time 4:44:28.22 Total Coindrops 660 Slot 0 Left 660 Slot 1 Right 0 Slot 2 DBV 0 Bonus Credits 0 Current Credits 20 Current Coins 0
--	--

SUPER ALPINE RACER OPERATOR'S MANUAL



Audits Menu	Track	Count	Percent
General 1	EVEREST	42	26.25%
General 2	MATTERHORN	58	36.25%
Courses	KILIMANJARO	60	37.50%
Course Wins			
Places			
Skiers			
Gameplay			
Exit			

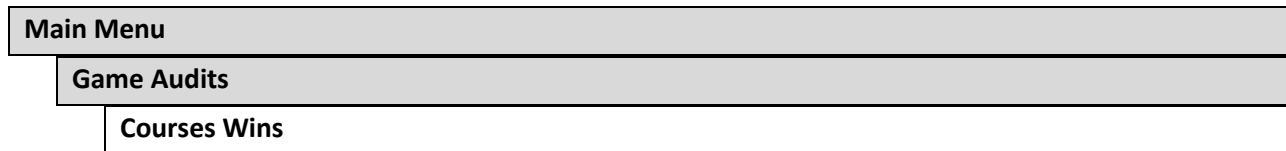

Audits Menu	Track	Wins	Percent
General 1	EVEREST	4	9.52%
General 2	MATTERHORN	6	10.34%
Course Wins	KILIMANJARO	10	16.67%
Places			
Skiers			
Gameplay			
Exit			

SUPER ALPINE RACER OPERATOR'S MANUAL

Main Menu
Game Audits
Placing

Audits Menu	Place	Count	Percent
General 1	1st Place	20	12.58%
General 2	2nd Place	55	34.59%
Courses	3rd Place	84	52.83%
Course Wins	4th Place	0	0.00%
Places	5th Place	0	0.00%
Skiers	6th Place	0	0.00%
Gameplay	7th Place	0	0.00%
Exit	8th Place	0	0.00%
	Average Place	2.40	
	Max Win Streak	1	
	Max Lose Streak	17	
	Cur Win Streak	0	
	Cur Lose Streak	9	
	Race Autopilots	0	

Main Menu
Game Audits
Skiers

Audits Menu	Skier	Count	Percent
General 1	punk1	30	18.75%
General 2	rider1	57	35.63%
Courses	girl1	44	27.50%
Course Wins	blnd1	29	18.13%
Places			
Skiers			
Gameplay			
Exit			

SUPER ALPINE RACER OPERATOR'S MANUAL

Main Menu
Game Audits
Gameplay

Audits Menu	Description	Count	Pct/Avg
General 1	Track 0 Gates Hit	759	90.36%
General 2	Track 1 Gates Hit	1121	96.39%
Courses	Track 2 Gates Hit	1027	85.58%
Course Wins	Total Gates Hit	2907	90.76%
Places	Track 0 Tricks	444	10.57
Skiers	Track 1 Tricks	650	11.21
Gameplay	Track 2 Tricks	751	12.52
Exit	Total Tricks	1845	11.53
	Track 0 Score	280679	6682.83
	Track 1 Score	308012	5310.55
	Track 2 Score	232874	3881.23
	Total Score	821565	5134.78
	Track 0 Airtime	22:04.22	0:31.53
	Track 1 Airtime	22:22.48	0:23.15
	Track 2 Airtime	29:29.38	0:29.49
	Total Airtime	1:13:56.08	0:27.73
	Track 0 Racetime	1:16:12.03	1:48.86
	Track 1 Racetime	1:46:40.92	1:50.36
	Track 2 Racetime	1:41:35.27	1:41.59
	Total Racetime	4:44:28.22	1:46.68

Main Menu
Pricing Adjustments

Pricing Adjustments	Credit Options
Freeplay No	Please note the following:
Money Unit COIN	Adjusting the number of coins
Coin Value 0.25	per credit will reset the
Coins / Bill Pulse 1	stored number of partial
Coins / Credit 4	credits.
Credits To Start 1	
Credits To Continue 1	
Max Credits 30	
Bonus Credits 0	
Credits For Bonus 5	
1st Place Free Game Yes	
1st Human Free Game No	
Sync All Adjustments	
Exit	

SUPER ALPINE RACER OPERATOR'S MANUAL

Setting	Default	Choices
Freeplay	No	Yes/No
Money Unit	USD	Card Swipes, USD, AUD, CAD, EUR, GBP,DEM,FRF,JPY,NLG,ITL,CHF,DKK,MXN,RUR,KRW,CNY
Coin Value	0.25	0.01, 0.05, 0.10, 0.25, 0.50, 1.00, 2.00, 5.00, 10.00, 20.00, 50.00, 100.00, 500.00, 1000.00, 10000.00
Coins per Bill Pulse	1	1, 2, 3, 4, 5, 10, 20, 25, 50, 100
Coins Per Credit	4	1-10
Credits To Start	1	1-10
Credits To Continue	1	1-10
Bonus Credits	0	Options: 0-10
Credits For Bonus	5	1-20
Max Credits	30	10, 15, 20, 25, 30, 35, 40, 45, 50
First Place Free Race	Yes	Yes/No
Multiplay Win Free Race	No	Yes/No

Main Menu
System Adjustments

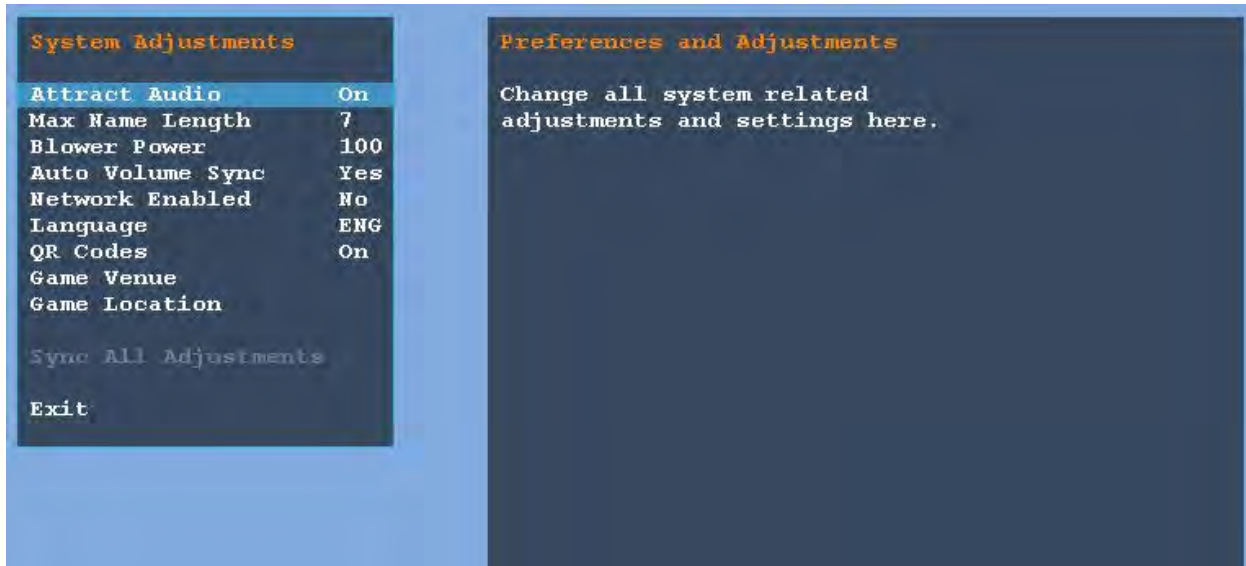

SUPER ALPINE RACER OPERATOR'S MANUAL

Settings, Defaults and Choices

Setting	Default	Choices
Attract Mode Audio	Yes	Yes, No
Max Name Length	7	3, 4, 5, 6, 7
Blower Power	100	0-100
Automatic Volume Sync	Yes	Yes, No
Network Enabled	No	Yes, No (Must set each unit ID and enable link separately.)
Language	English	English, Russian, Chinese, Japanese
QR Codes	On	On, Off
Game Venue	None	Enter Venue Name to be displayed.
Game Location	None	Enter Location Name to be displayed.

NOTE ON LINKING:

Linking three or more games requires a network hub and appropriate number of network patch cables. These items must be purchased separately. Follow the network hubs hookup instructions.

Use the crossover network cable provided with the game for linking 2 games. Network settings must be set for each linked unit. Up to 8 units can be linked. Press "Test" button to access the game settings and diagnostics menu.

Linking 2 or more Games:

1. Set "Network Enabled" to "YES" under "System Adjustments".
2. Set a unique "Unit ID" for each unit.
3. The new settings will be automatically saved when exiting "Test Menu"
4. Verify successful network link by playing a test game.

SUPER ALPINE RACER OPERATOR'S MANUAL

Main Menu
Game Adjustments



Settings, Defaults and Choices

Setting	Default	Choices
Game Difficulty	5	1(easier)-> 10(harder)
Start Time Bonus	80	30-120 seconds
Checkpoint Bonus	10	10-100
Speed Measurements	MPH	MPH, KPH
Plays For Score Reset	10000	1000-20000
Autopilot Available	Yes	Yes, No
Name Entry After Race	Yes	Yes, No
Girls and Crowds	Yes	Yes, No
Enable Girl Video	Yes	Yes,No
Enable Girl Racer Crowd	Yes	Yes,No

Main Menu

SUPER ALPINE RACER OPERATOR'S MANUAL

Utilities

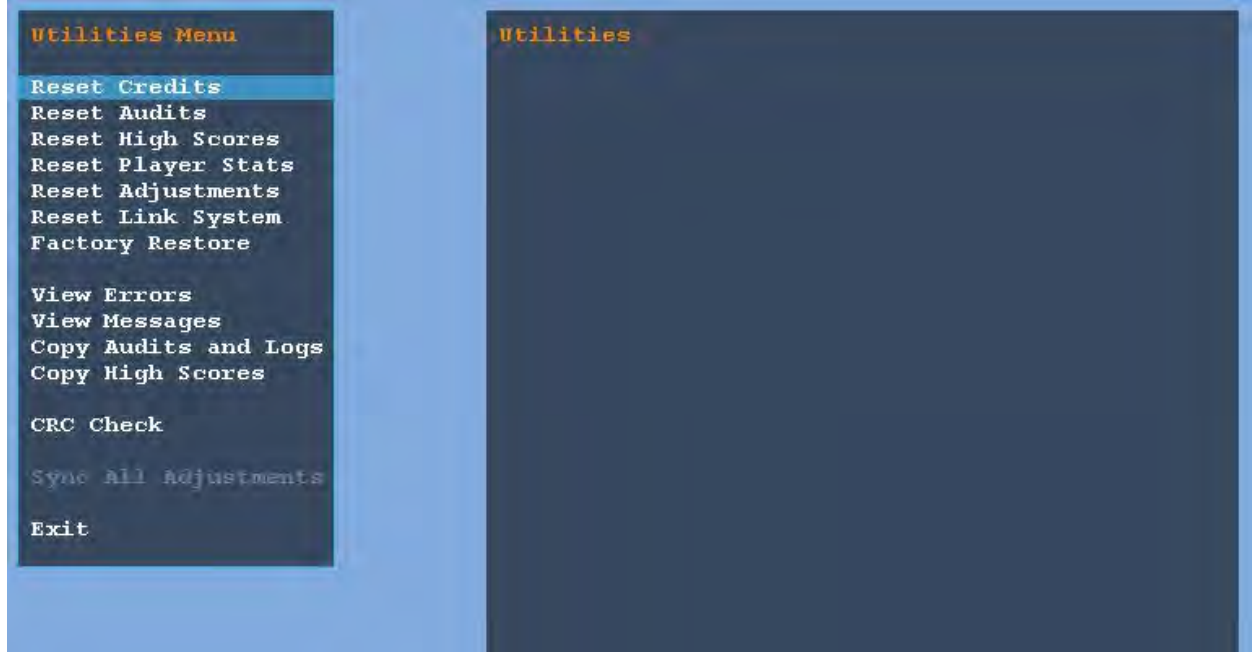

Main Menu

Calibration

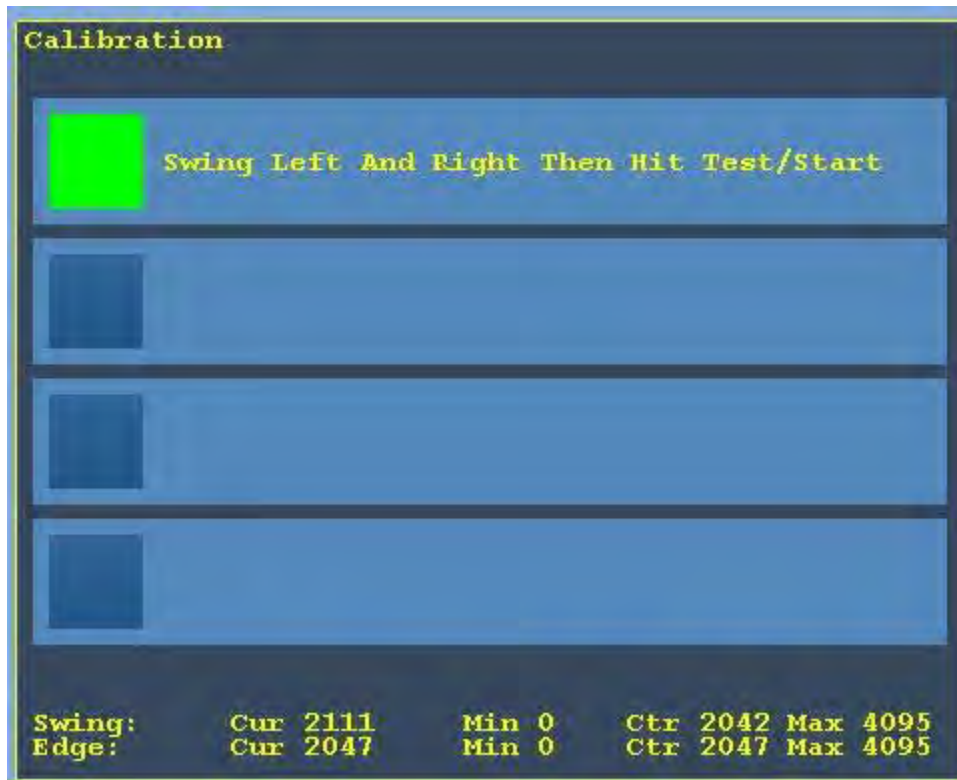

SUPER ALPINE RACER OPERATOR'S MANUAL

Main Menu

Game Volume

Adjust game volume during play mode only. Attract volume is adjusted separately. Automatic Volume Sync allows for all linked units to be adjusted simultaneously.

Main Menu

Attract Volume

Adjust attract or standby volume only.

SUPER ALPINE RACER OPERATOR'S MANUAL

Maintenance

Hard Drive Recovery

Symptoms requiring hard drive recovery include

- File Test reports bad or missing files.
- Game fails to finish loading during startup.
- After resetting the AC power, an error is reported.
- You are prompted to insert a boot DVD.
- Erratic Game or Attract Mode.
- Garbled characters
- Bad audit files

To identify corrupt files, press Test, choose System Test Menu and run the CRC Check.

The only way to repair corrupt files is to recover the hard drive, as detailed below.

COMPUTER

The computer contains sensitive components, including a hard drive. Do not handle roughly. Call your distributor before servicing its internal components. Ask about warranty information as it relates to the PC.

Do **not** use the PC on/off switch. Turn AC power on or off with the cabinet power switch.

1. With game and PC on, verify that the RIO board has power. If not, see Troubleshooting.
2. Open the Coin door.
3. Open the PC DVD-ROM tray by reaching back to the PC and pressing the Open/Close button on the drive bay.
4. Insert the first of two restore DVDs (labeled *Disc 1*) into the tray.
5. Close the tray by pressing the Open/Close button again.
6. Turn cabinet power switch to OFF. Wait 30 seconds.
7. Turn cabinet power switch to ON.
8. Recovery begins automatically when PC boots up.
9. If recovery does not begin, check to ensure disc is inserted correctly and is not damaged.
10. Initial software loading may take several minutes. Check progress periodically.
Do not interrupt power or reset the game during recovery.
11. When software has been loaded, a message indicates that restore is complete. When instructed to remove disc, open DVD-ROM drive tray and remove disc.
12. Turn cabinet power switch off.
13. **After 30 seconds, turn cabinet power switch on.**
14. Game will reboot and enter calibration mode.
15. Re-calibrate controls.

SUPER ALPINE RACER OPERATOR'S MANUAL

BIOS Settings/Power Management

NOTICE

The PC ships with correct BIOS settings. Making changes to the BIOS different from the description below may adversely affect game functions.

This BIOS setting lets the PC automatically power up. With the setting enabled, the PC reboots when it detects AC power. This eliminates the need to manually turn the PC back on after power disruption.

Do **not** use the PC on/off switch. Turn AC power on or off with the cabinet power switch.

1. Turn cabinet power switch off.
2. Open rear of cabinet.
3. Connect a USB keyboard to the PC.
4. While holding the F10 key on the keyboard down, turn cabinet power switch on.
5. When the BIOS menu screen appears, make the following adjustments.

(SETTINGS BELOW ARE SPECIFIC TO HP6005 PC. PLEASE CHECK RAWTHRILLS.COM FOR LATEST INFORMATION ON BIOS SETTINGS AND OTHER TECHNICAL UPDATES)

STORAGE => Storage Options => SATA Emulation : "Native Mode IDE"

ADVANCED => Power On Options => After Power Loss : "On"

6. Follow instructions on screen to save and exit.
7. PC will reset and load the game.

SUPER ALPINE RACER OPERATOR'S MANUAL

MECHANICAL ILLUSTRATIONS AND ELECTRICAL SYSTEM DIAGRAM

VISIT WWW.RAWTHRILLS.COM FOR THE LATEST INFORMATION REGARDING SUPER ALPINE RACER

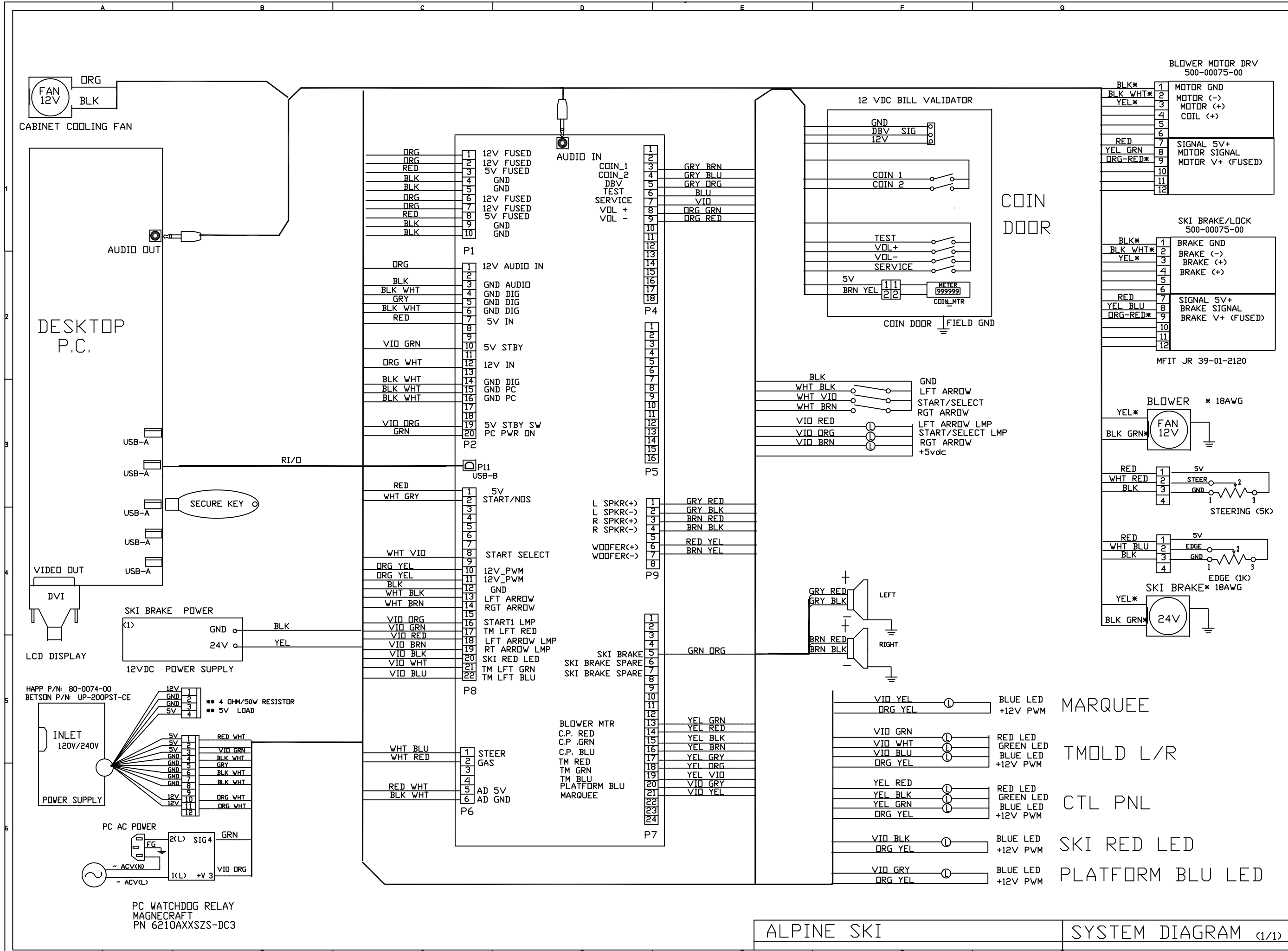

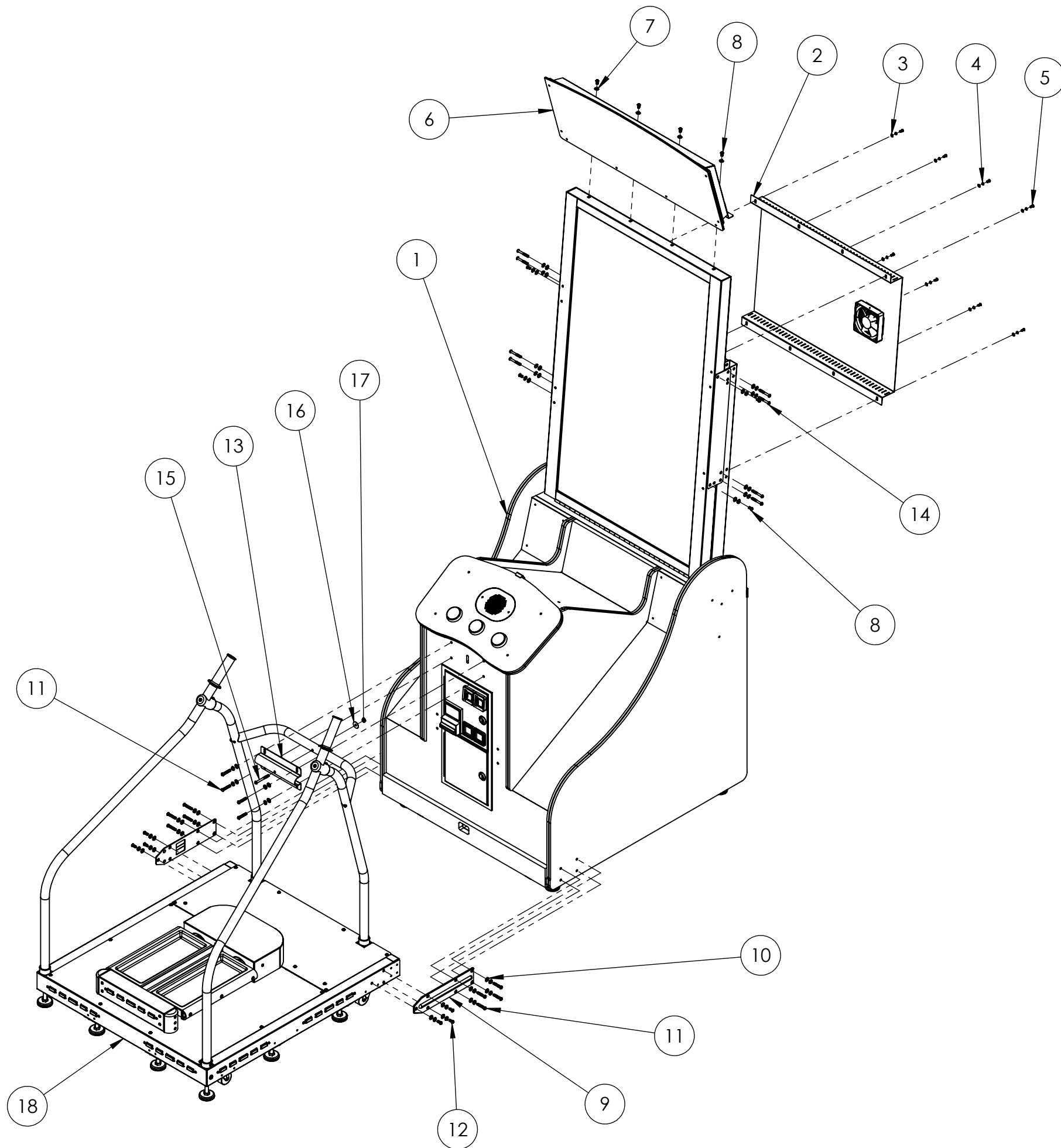

ITEM NO.	PART NUMBER	DESCRIPTION	QTY.
1	Alpine_Front_Cab_Assy	Super Alpine Racer - Front Cabinet Assembly	1
2	Alpine_LCD_Cover_Assy	Super Alpine Racer - Monitor Back Cover Assembly	1
3	McMaster-Carr - 96765A125	Black 18-8 Stainless Steel Flat Washer, #10 Screw Size, 7/16" OD, .03" Thick	8
4	McMaster-Carr - 91169A170	Black Steel Split Lock Washer, M5 Screw Size, 9.2mm OD, 1.1mm Thick	8
5	McMaster-Carr - 96075A187	Black Alloy Steel Pin-In Torx Button Socket Cap Screw, 10-32 Thread, 1/2" Length	8
6	Alpine_Marquee_Assy	Super Alpine Racer - Marquee Assembly	1
7	McMaster-Carr - 91169A200	Black Steel Split Lock Washer, M8 Screw Size, 14.8mm OD, 1.9mm Thick	34
8	McMaster-Carr - 96075A211	Black Alloy Steel Pin-In Torx Button Socket Cap Screw, 1/4-20 Thread, 1/2" Length	8
9	600-01175-01	Platform to Cabinet Connecting Bracket	2
10	McMaster-Carr - 96765A140	Black Steel Flat Washer, 1/4" Screw Size, 5/8" OD, .04" Thick	30
11	McMaster-Carr - 96075A231	Black Alloy Steel Pin-In Torx Button Socket Cap Screw, 1/4-20 Thread, 1 1/2" Length	12
12	McMaster-Carr - 96075A219	Black Alloy Steel Pin-in Torx Button Socket Cap Screw, 1-4"-20 Thread, 3/4" Length	6
13	600-01350-01	Pole to Cabinet Bracket	1
14	McMaster-Carr - 91900A549-BLACK	Stainless Steel Pin-in Torx Button Socket Cap Screw, 1/4"-20 Thread, 2" Length, Paint Black	8
15	McMaster-Carr - 91255A547	Black Alloy Steel Button Head Socket Cap Screw, 1/4-20 Thread, 2 1/2" Length	1
16	McMaster-Carr - 91090A108	Zinc-Plated Steel Large-Diameter Flat Washer, 1/4" Screw Size, 1" OD, .05" Thick	1
17	McMaster-Carr - 90675A029	Zinc-Plated Steel Machine Screw Nut with Tooth Washer, 1/4-20 Thread, 7/16" Width, 3/16" Height	1
18	Alpine_Pedestal_Assy	Super Alpine Racer - Pedestal Assembly	1

Super Alpine Racer - 55" Assembly



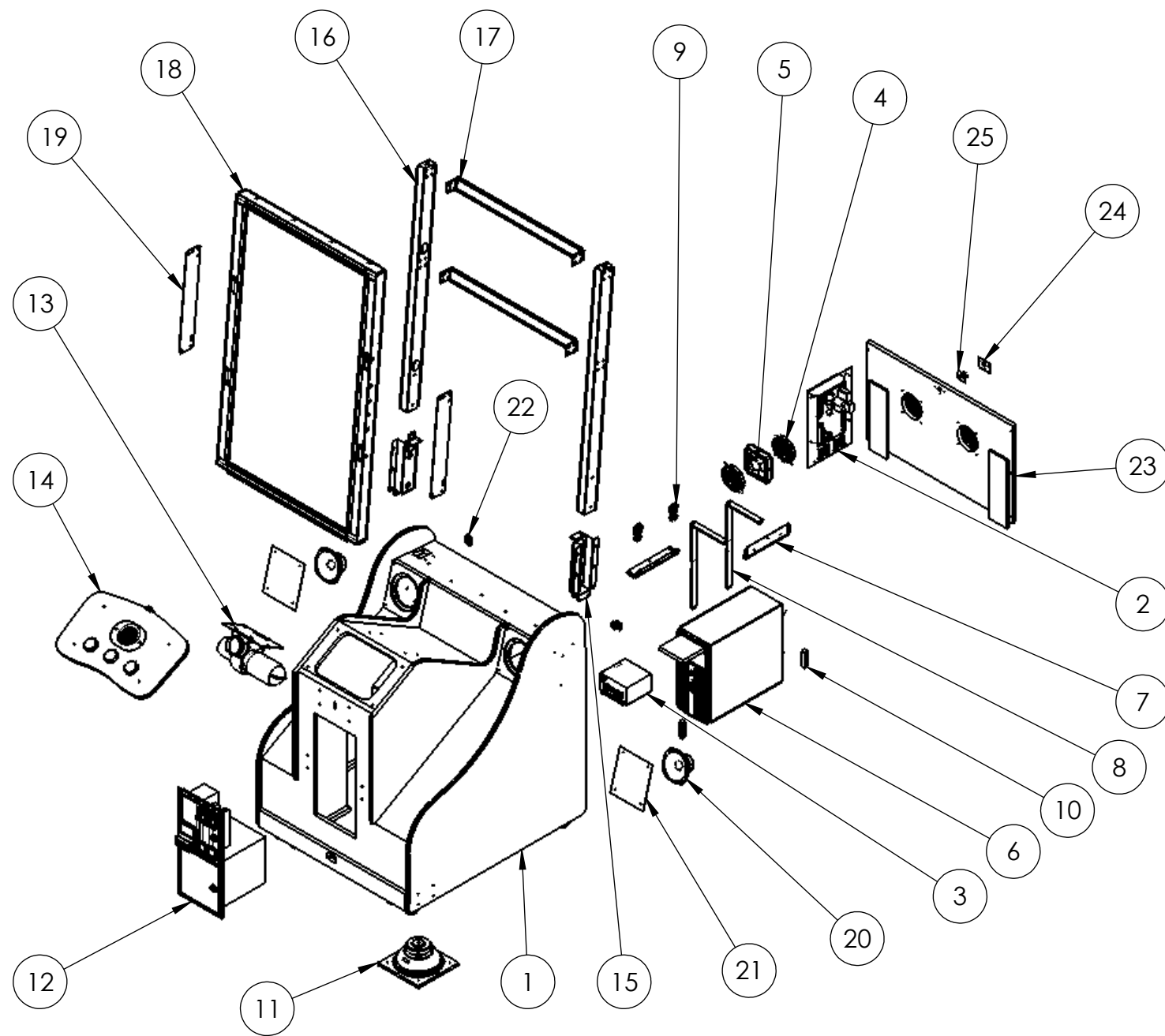

- NOT DISPLAYED:
- (1) 810-00053-01: Service Bracket
 - (1) 800-00040-00: Solid State Relay
 - (1) 24V Power Supply
 - (1) Load Resistor and Bracket
 - (2) 603-00718-01: LED T-Molding (65.5")
 - (2) 500-00131-01: RGB LED Strips (165 CM)
 - (2) Monitor Safety Suspension Chains

ITEM NO.	PART NUMBER	DESCRIPTION	QTY.
1	601-00651-01	Alpine 55" LCD Cabinet	1
2	Alpine_RIO_Hardware_Assy	RIO Assembly (with Mounting Plate)	1
3	2-1-02-00-00-017	APS Power Supply (Bracket #90-AP188)	1
4	800-00001-00	120mm Wire Fan Guard	2
5	820-00012-00	Cooling Fan(standard size): 12VDC, 3W, 80CFM	1
6	HP6005	(or approved equivalent PC)	1
7	600-00901-01	Bracket - PC Strap Mounting	2
8	McMaster-Carr - 87425K76	PC Mounting Nylon Strip: 0.075" Thick, 1" Width, Black (56" Length)	2
9	McMaster-Carr - 29705T86	Plastic Buckle for Webbing NO Sew Squeeze-Release for 1" Wide Webbing	2
10	601-00580-01	PC Wood Cleat	2
11	Alpine_Woofer_Assy	Super Alpine Racer - Woofer Mounting Assembly	1
12	800-00005-01	Happ: Mid-Width Coin Door Assembly	1
13	Alpine_Blower_Assy	Super Alpine Racer - Blower Assembly	1
14	Alpine_CP_Assy	Super Alpine Racer - Control Panel Assembly	1
15	600-01339-01	Mounting Tube Stop Bracket	2
16	600-01330-01	Monitor Mounting Tube	2
17	600-01337-01	Monitor Mounting Beam	2
18	Alpine_55_LCD_Assy	Super Alpine Racer - Monitor Enclosure Assembly	1
19	600-01366-01	Monitor Mounting Plate	2
20	2-1-10-00-00-000	Goldwood: 5.25", 8 Ohm Full Range Speaker	2
21	600-01341-01	Speaker Grill	2
22	600-01357-01	Shallow LED T-Molding Clip	2
23	601-00654-01	Alpine - Cabinet Lower Back Door	1
24	600-00043-01	Lock Retainer Plate	1
25	150-00001-00	Standard Door Lock Assembly (for 3/4" Panels)	1

Super Alpine Racer - Front Cabinet Assembly



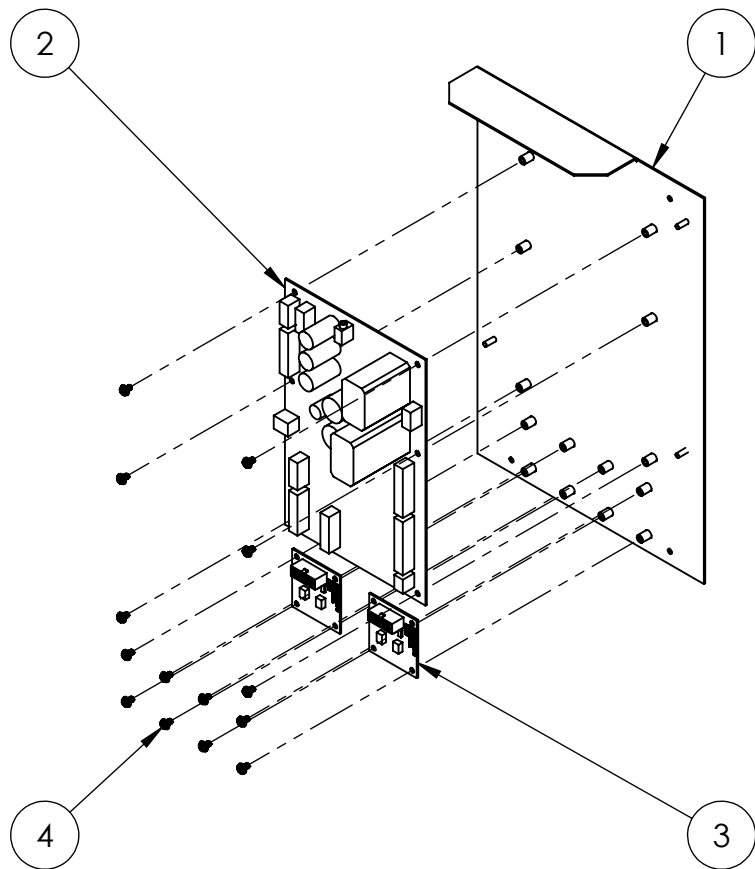

ITEM NO.	PART NUMBER	DESCRIPTION	QTY.
1	600-01336-01	RIO Mounting Plate (w/ Blower PCBs)	1
2	500-00040-01	RIO PCB	1
3	500-00075-02	Snow Blower PCB	2
4	McMaster-Carr - 90316A190	18-8 Stainless Steel Hex Washer Head Slotted Machine Screw, 8-32 Thread, 1/4" Length	14

ITEM NO.	PART NUMBER	DESCRIPTION	QTY.
1	601-00685-01	8" Woofer Board	1
2	2-1-18-00-00-000	Goldwood: 8" Woofer, 4 Ohm, Poly-Mica Cone	1
3	McMaster-Carr - 90054A196	Zinc-Plated Steel Slotted Hex Washer Head Screw, #8 Size, 5/8" Length	4
4	Wire_Mesh_Grill	7.25" x 7.25"	1

RIO Assembly (with Mounting Plate)

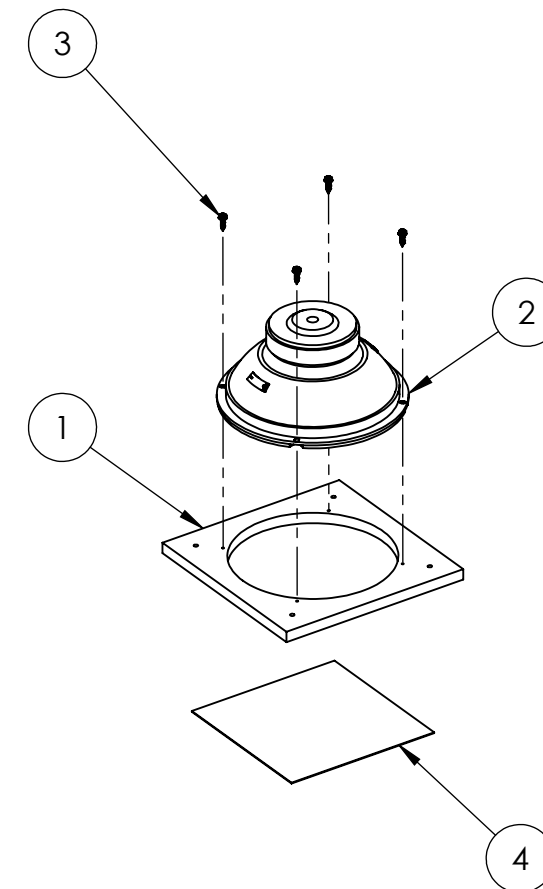

Super Alpine Racer - Woofer Mounting Assembly

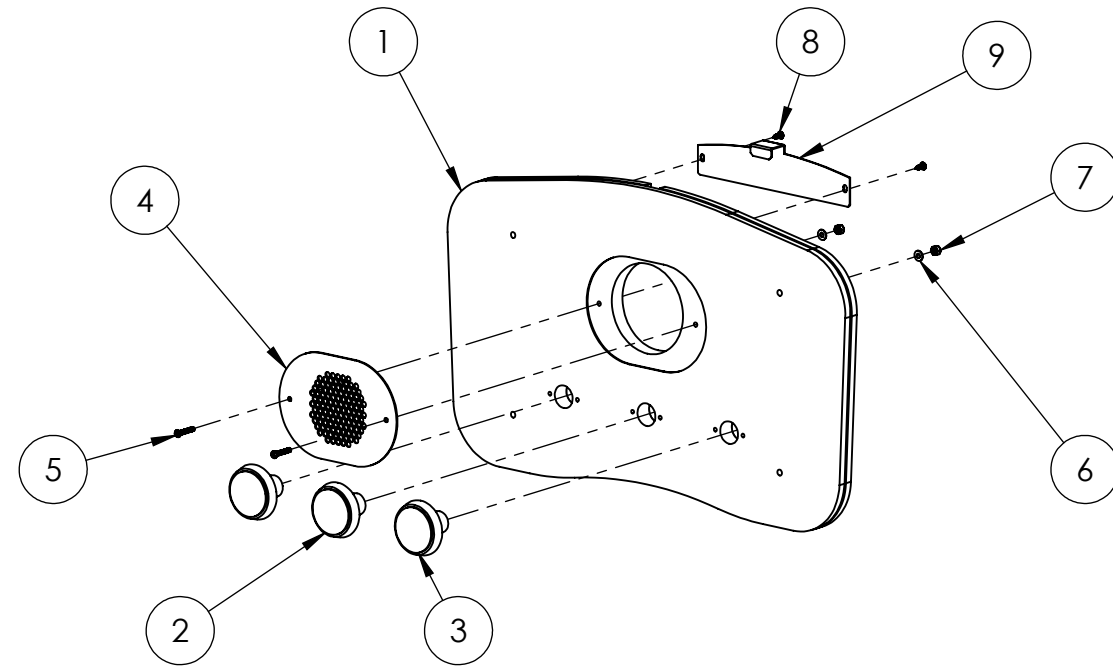

ITEM NO.	PART NUMBER	DESCRIPTION	QTY.
1	601-00658-01	Control Panel Wood	1
2	702-00058-01	Happ: Large Round Green Pushbutton with Locking Lampholder (6VDC White LED), .187 Gold MS - START	1
3	702-00059-01	Happ: Large Round White Pushbutton with Locking Lampholder (6VDC White LED), .187 Gold MS - ARROW	2
4	600-01340-01	Blower Grill	1
5	McMaster-Carr - 96075A147	Black Alloy Steel Pin-in Torx Button Socket Cap Screw, 8-32 Thread, 1" Length	2
6	McMaster-Carr - 90126A512	Zinc-Plated Steel Flat Washer, #8 Screw Size, 7/16" OD, .05" Thick	2
7	McMaster-Carr - 90631A009	Zinc-Plated Grade 2 Steel Nylon-Insert Hex Locknut, 8-32 Thread, 11/32" Width, 15/64" Height	2
8	McMaster-Carr - 95638A194-BLACK	18-8 Stainless Steel Pin-In Torx Button Head Sheet Metal Screw, #8 Size, 1/2" Long, Paint Black	2
9	600-01355-01	Control Panel T-Molding Plate	1

NOT DISPLAYED:

(1) 603-00718-01: LED T-Molding (63.125")

(1) 500-00131-01: RGB LED Strip (160 CM)

Super Alpine Racer - Control Panel Assembly



ITEM NO.	PART NUMBER	DESCRIPTION	QTY.
1	600-01169-01	Blower Bracket	1
2	604-00022-01	Johnson Blower	1
3	600-00975-01	Foam Filter Bag	1
4	800-00038-01	3" Hose Clamp	1
5	McMaster-Carr - 90316A196	18-8 Stainless Steel Hex Washer Head Slotted Machine Screw, 8-32 Thread, 5/8" Length	4
6	McMaster-Carr - 91102A735	Zinc-Plated Steel Split Lock Washer, #8 Screw Size, 0.3" OD, .04" Thick	4
7	McMaster-Carr - 90126A512	Zinc-Plated Steel Flat Washer, #8 Screw Size, 7/16" OD, .05" Thick	4

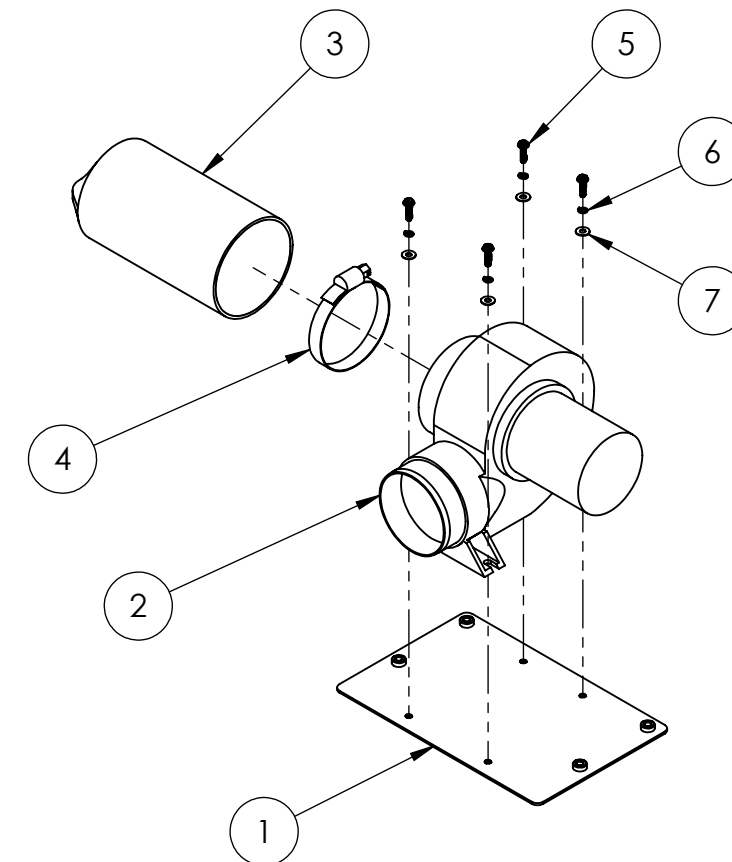

Super Alpine Racer - Blower Assembly

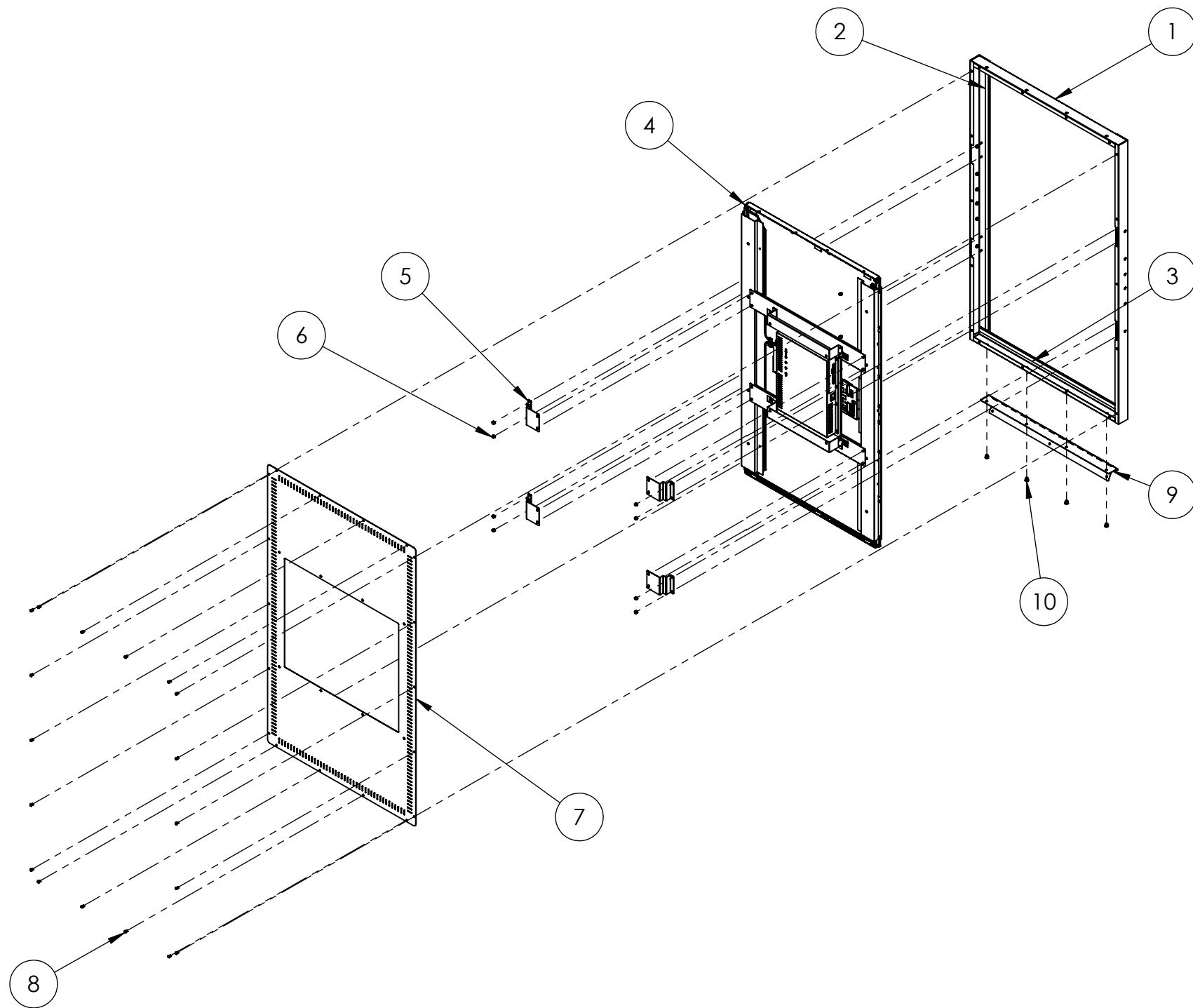

ITEM NO.	PART NUMBER	DESCRIPTION	QTY.
1	608-00181-01	55" Monitor Frame Front Bezel Weldment	1
2	Monitor_Foam_Tape (47.25)	Black: 5/8" W x 1/8" T x 47 1/4" L	2
3	Monitor_Foam_Tape (30.75)	Black: 5/8" W x 1/8" T x 37 3/4" L	2
4	809-00012-01	Kortek 55" LCD Open Panel w/ Glass	1
5	600-01331-01	55" Kortek Retainer Bracket	4
6	McMaster-Carr - 90675A195	Zinc-Plated Steel Machine Screw Nut with Tooth Washer, 10-32 Thread, 3/8" Width, 1/8" Height	8
7	600-01332-01	55" Kortek Back Plate	1
8	McMaster-Carr - 96075A183	Black Alloy Steel Pin-in Torx Button Socket Cap Screw, 10-32 Thread, 3/8" Length	18
9	600-01365-01	Monitor Hinge Bracket	1
10	McMaster-Carr - 92865A535	Zinc-Plated Grade 5 Steel Cap Screw, 1/4-20 Thread, 3/8" Length	4



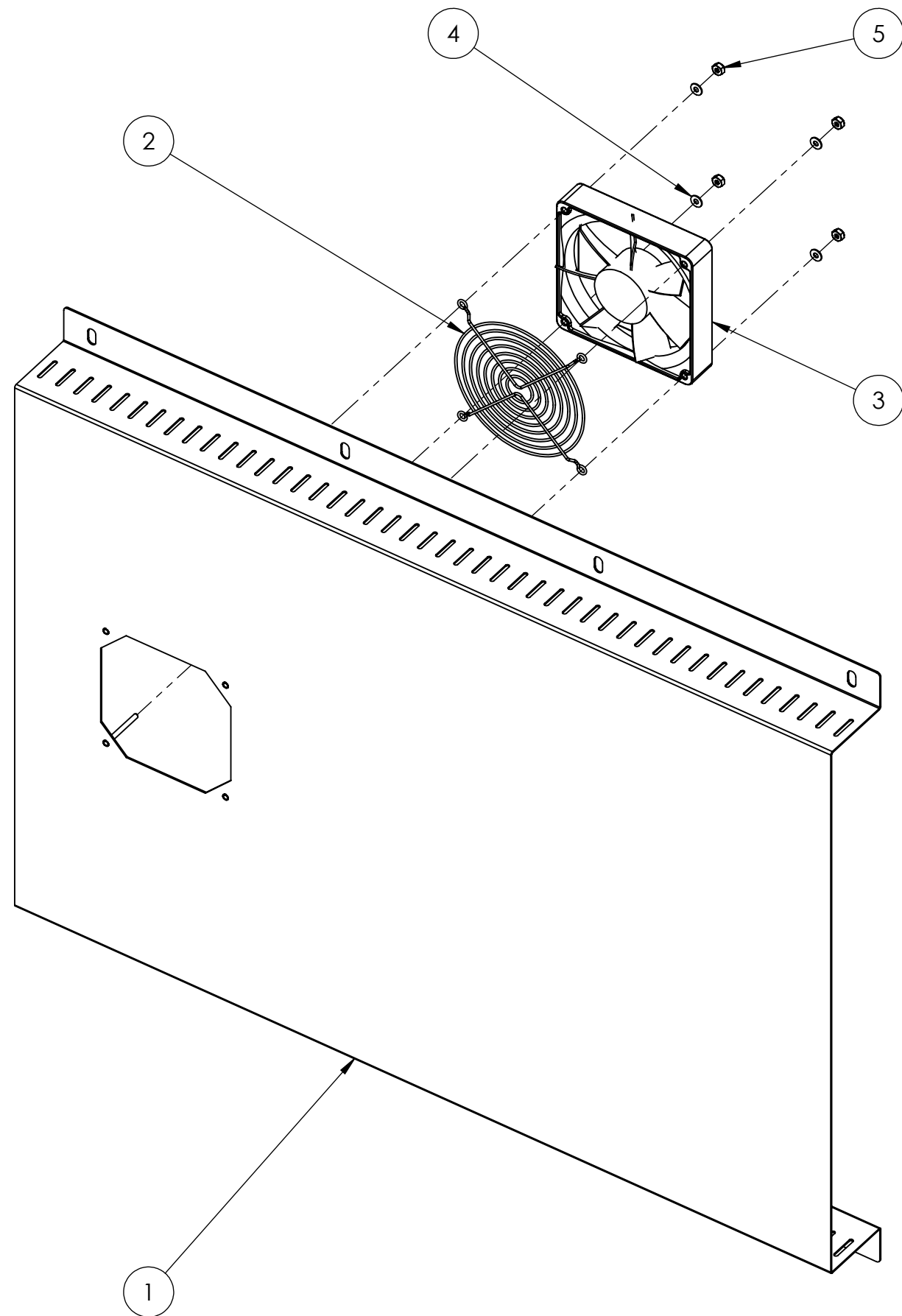

ITEM NO.	PART NUMBER	DESCRIPTION	QTY.
1	600-01333-01	55" Monitor Cover Box	1
2	800-00001-00	120mm Wire Fan Guard	1
3	820-00012-00	Cooling Fan(standard size): 12VDC, 3W, 80CFM	1
4	McMaster-Carr - 90126A509	Zinc-Plated Steel Flat Washer, #6 Screw Size, 3/8" OD, .05" Thick	4
5	McMaster-Carr - 90631A007	Zinc-Plated Grade 2 Steel Nylon-Insert Hex Locknut, 6-32 Thread, 5/16" Width, 11/64" Height	4

Super Alpine Racer - Monitor Back Cover Assembly



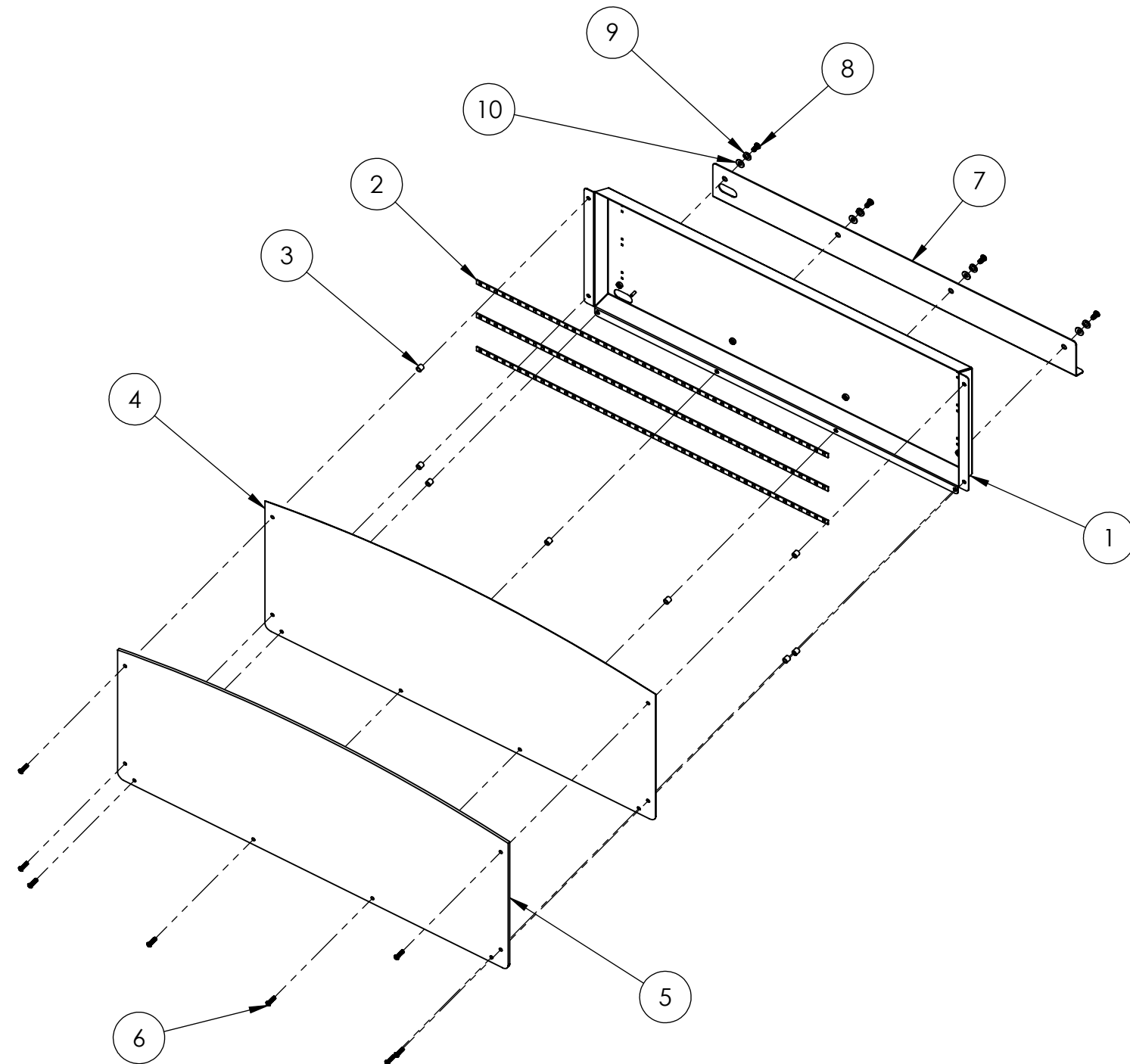

ITEM NO.	PART NUMBER	DESCRIPTION	QTY.
1	600-01358-01	Marquee Box	1
2	500-00162-01 (75CM)	White Flexible LED Tape w/ Foam Backing (75CM - 45 LEDs)	3
3	600-00998-01	3/8" Spacer	8
4	606-00929-01	Marquee Translite	1
5	600-01360-01	Marquee PETG Plastic	1
6	McMaster-Carr - 96075A191	Black Alloy Steel Pin-in Torx Button Socket Cap Screw, 10-32 Thread, 3/4" Length	8
7	600-01359-01	Marquee Mounting Bracket	1
8	McMaster-Carr - 96075A211	Black Alloy Steel Pin-In Torx Button Socket Cap Screw, 1/4-20 Thread, 1/2" Length	4
9	McMaster-Carr - 91169A200	Black Steel Split Lock Washer, M8 Screw Size, 14.8mm OD, 1.9mm Thick	4
10	McMaster-Carr - 96765A140	Black Steel Flat Washer, 1/4" Screw Size, 5/8" OD, .04" Thick	4



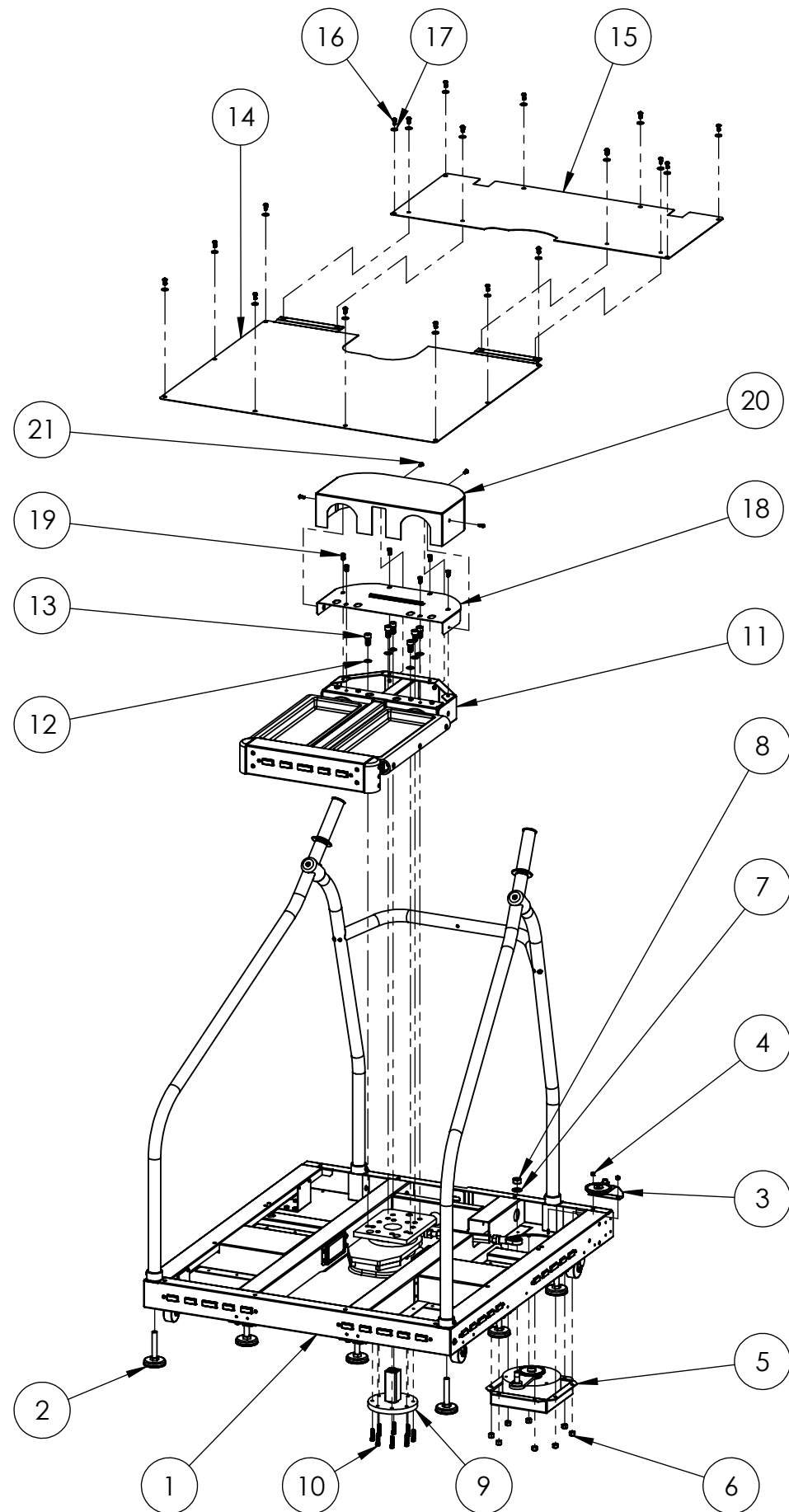

ITEM NO.	PART NUMBER	DESCRIPTION	QTY.
1	Alpine_Main_Pedestal_Sub_Assy	Super Alpine Racer - Main Pedestal Sub-Assembly	1
2	Pedestal Leg Leveler	1/2-13 Thread, 4" Length	2
3	Alpine_Pot_Assy	Super Alpine Racer - Pot and Gear Assembly	1
4	McMaster-Carr - 90631A411	Zinc-Plated Grade 2 Steel Nylon-Insert Hex Locknut, 10-32 Thread, 3/8" Width, 15/64" Height	2
5	Alpine_Electric_Brake_Assy	Super Alpine Racer - Electric Brake Assy	1
6	McMaster-Carr - 90648A029	Zinc-Plated Grade 2 Steel Nylon-Insert Heavy Hex Locknut, 1/4"-20 Thread, 1/2" Wide, 3/8" High	8
7	McMaster-Carr - 91166A290	DIN 125 Zinc-Plated Class 4 Steel Flat Washer, M12 Screw Size, 24mm OD, 2.3mm Thick	1
8	McMaster-Carr - 90591A181	Metric Zinc-Plated Class 8 Steel Hex Nut, M12 Thread, 1.75mm Pitch, 19mm Wide, 10mm High	1
9	Alpine_Rosta_Plate_Assy	Super Alpine Racer - Rosta & Plate Assy	1
10	McMaster-Carr - 91290A330	Black Alloy Steel Class 12.9 Socket Head Cap Screw, M6 Thread, 25mm Length, 1mm Pitch	8
11	Alpine_Platform_Assy	Super Alpine Racer - Platform Assembly	1
12	McMaster-Carr - 91106A133	Black Steel Internal-Tooth Lock Washer, M10 Screw Size, 18mm OD, 0.9mm Thick	6
13	McMaster-Carr - 91290A516	Black Class 12.9 Alloy Steel Socket Head Cap Screw, M10 Thread, 1.5mm Pitch, 20mm Length	6
14	600-01119-01	Rear Pedestal Cover	1
15	600-01120-01	Front Pedestal Cover	1
16	McMaster-Carr - 96075A211	Black Alloy Steel Pin-in Torx Button Socket Cap Screw, 1/4"-20 Thread, 1/2" Length	18
17	McMaster-Carr - 96765A140	Black Steel Flat Washer, 1/4" Screw Size, 5/8" OD, .04" Thick	18
18	600-01203-01	Ski Front Cover	1
19	McMaster-Carr - 93070A143	Low-Profile Class 8.8 Steel Socket Head Cap Screw, M6 Thread, 1mm Pitch, 12mm Length	6
20	600-01208-01	Front Metal Cover	1
21	McMaster-Carr - 96075A187	Black Alloy Steel Pin-In Torx Button Socket Cap Screw, 10-32 Thread, 1/2" Length	4

Super Alpine Racer - Pedestal Assembly



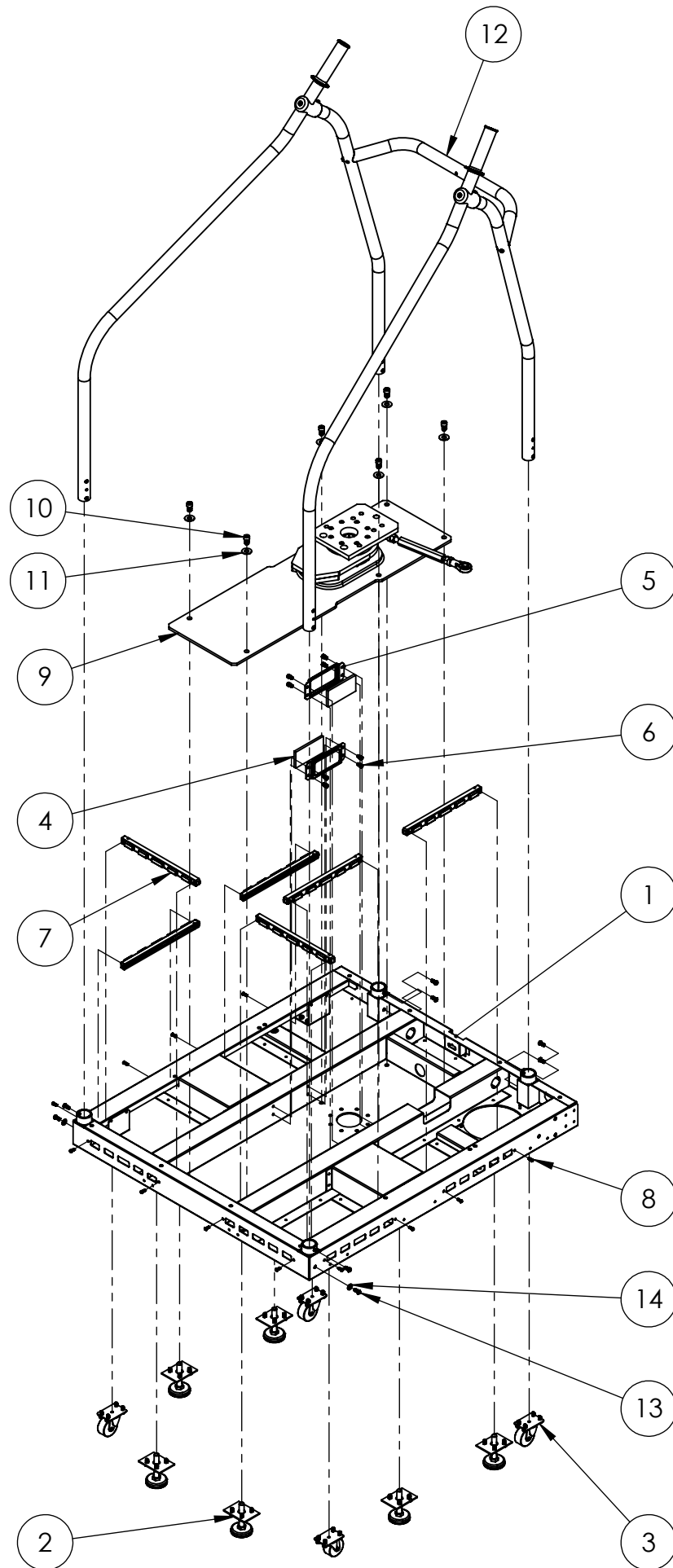

ITEM NO.	PART NUMBER	DESCRIPTION	QTY.
1	608-00166-01	Pedestal Frame Assembly	1
2	Pedestal_Leg_Leveler_Assy	Super Alpine Racer - Leg Leveler Assembly	6
3	Caster_&_Hardware_Assy	Super Alpine Racer - Pedestal Casters	4
4	600-01348-01	Stop Pad	2
5	600-01349-01	Stop Pad Holder Bracket	2
6	McMaster-Carr - 90128A241	Zinc-Plated Alloy Steel Socket Head Cap Screw, 1/4"-20 Thread, 3/8" Length	8
7	Alpine_Pedestal_Light_Assy	Super Alpine Racer - Pedestal Light Assembly	6
8	McMaster-Carr - 96075A139	Black Alloy Steel Pin-in Torx Button Socket Cap Screw, 8-32 Thread, 1/2" Length	12
9	Alpine_Main_Mech_Assy	Super Alpine Racer - Platform Mechanism Assembly	1
10	McMaster-Carr - 91251A621	Black Alloy Steel Socket Head Cap Screw, 3/8"-16 Thread, 5/8" Length	6
11	McMaster-Carr - 90108A417	Zinc-Plated Steel Type A USS Flat Washer, 3/8" Screw Size, 1" OD, .06" Thick	6
12	Alpine_Ski_Pole_Assy	Super Alpine Racer - Ski Poles	1
13	McMaster-Carr - 96075A219 - Cut to .625in	Black Alloy Steel Pin-in Torx Button Socket Cap Screw, 1-4"-20 Thread, 5/8" Length	8
14	McMaster-Carr - 96765A140	Black Steel Flat Washer, 1/4" Screw Size, 5/8" OD, .04" Thick	2

Super Alpine Racer - Main Pedestal Sub-Assembly



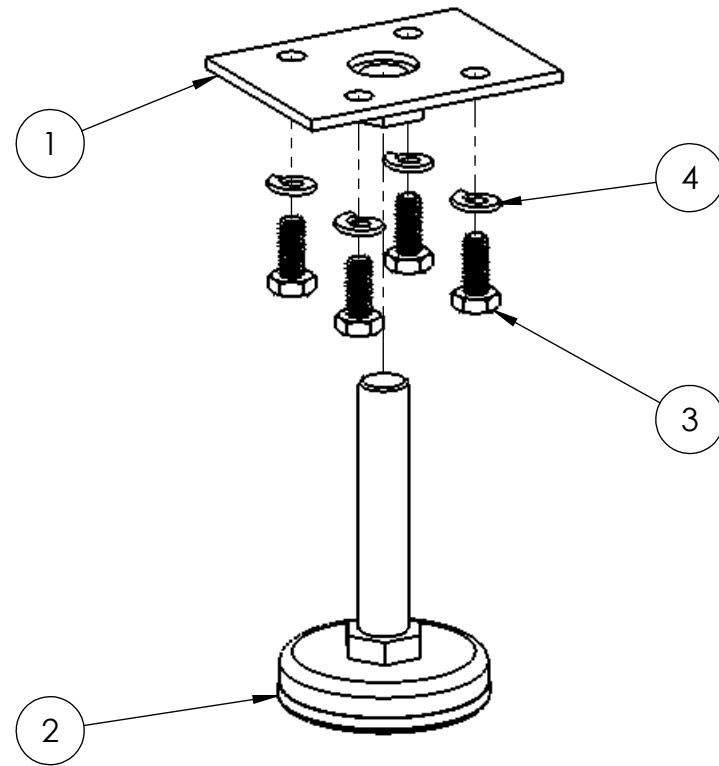

ITEM NO.	PART NUMBER	DESCRIPTION	QTY.
1	600-01351-01	Leg Leveler Bracket	1
2	Pedestal Leg Leveler	1/2-13 Thread, 4" Length	1
3	McMaster-Carr - 92620A539	Grade 8 Steel Cap Screw, 1/4"-20 Thread, 5/8" Length	4
4	McMaster-Carr - 91101A229	Steel Split Lock Washer, 1/4" Screw Size, .49" OD, .06" Thick	4

ITEM NO.	PART NUMBER	DESCRIPTION	QTY.
1	Pedestal Caster	2" Wheel, 2-7/16" Mounting Height	1
2	McMaster-Carr - 92620A539	Grade 8 Steel Cap Screw, 1/4"-20 Thread, 5/8" Length	4
3	McMaster-Carr - 91101A229	Steel Split Lock Washer, 1/4" Screw Size, .49" OD, .06" Thick	4

Super Alpine Racer - Leg Leveler Assembly

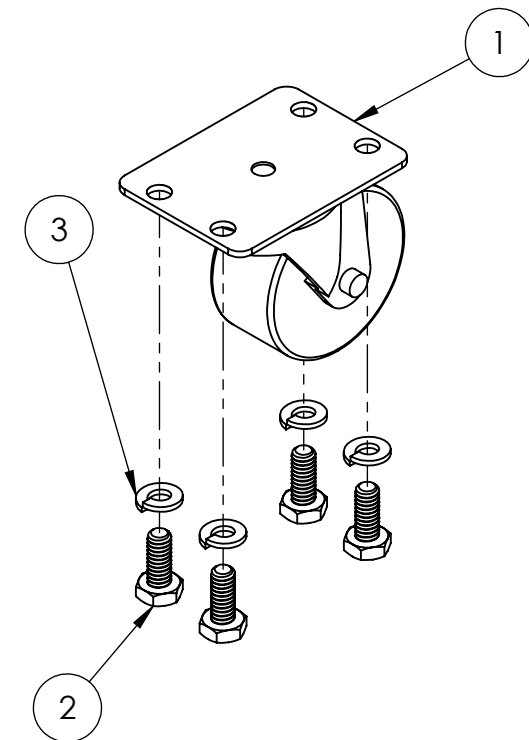

Super Alpine Racer - Pedestal Casters

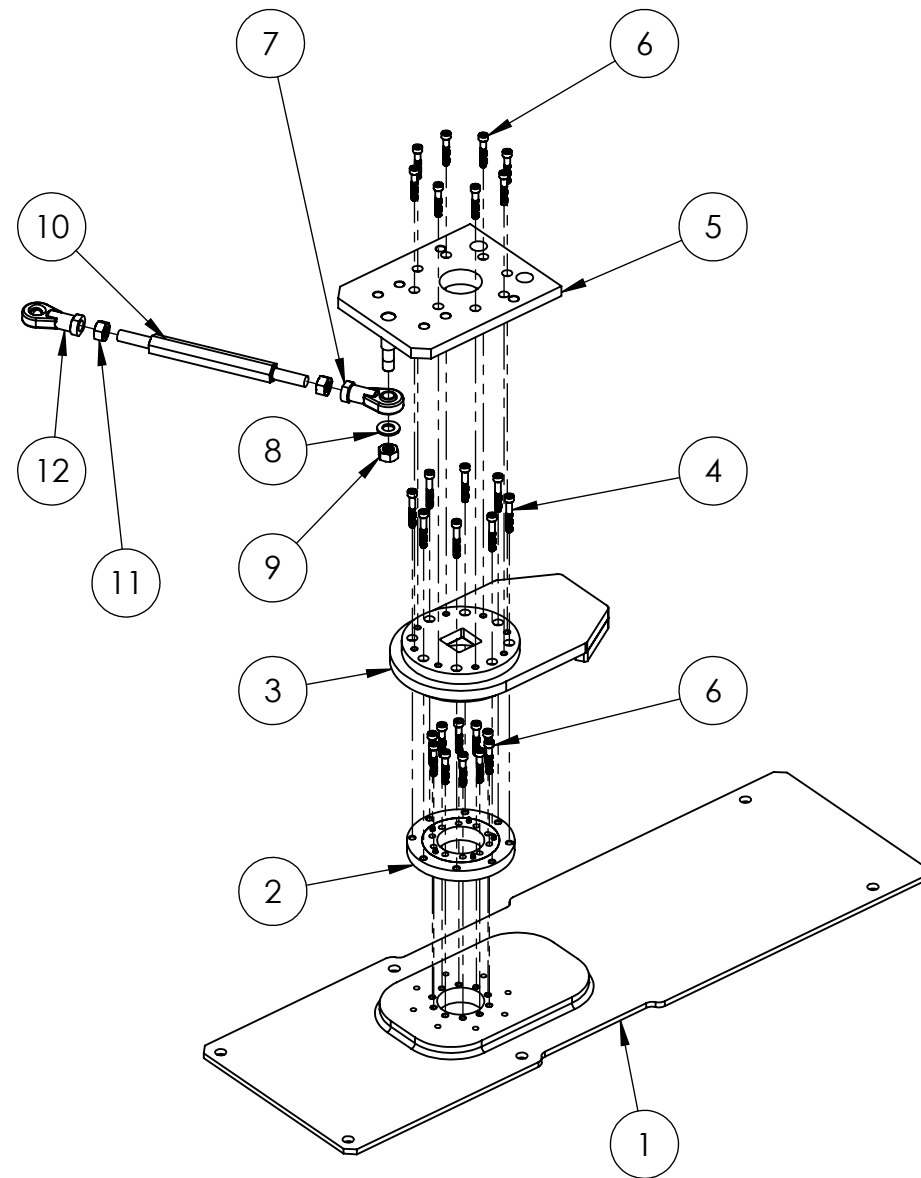

ITEM NO.	PART NUMBER	DESCRIPTION	QTY.
1	600-01183-01	Bottom Mech Plate	1
2	600-01322-01	Cross Roller Ring	1
3	600-01182-01	Stop Plate	1
4	McMaster-Carr - 91290A336	Black Class12.9 Alloy Steel Socket Head Cap Screw, M6 Thread, 1mm Pitch, 40mm Length	8
5	600-01181-01	Plate Below Skis	1
6	McMaster-Carr - 91290A256	Black Class12.9 Alloy Steel Socket Head Cap Screw, M5 Thread, 0.8mm Pitch, 35mm Length	18
7	600-01364-01	Female Rod End, Right Hand M12 Thread, 1.75mm Pitch, M12 Ball ID	1
8	McMaster-Carr - 91166A290	DIN 125 Zinc-Plated Class 4 Steel Flat Washer, M12 Screw Size, 24mm OD, 2.3mm Thick	1
9	McMaster-Carr - 90591A181	Metric Zinc-Plated Class 8 Steel Hex Nut, M12 Thread, 1.75mm Pitch, 19mm Wide, 10mm High	2
10	600-01187-01	Threaded Hex Turnbuckle	1
11	McMaster-Carr - 93695A190	Zinc-Plated Class 8 Steel Left-Hand Thread Hex Nut, M12 Thread, 1.75mm Pitch, 19mm Width, 10mm Height	1
12	600-01363-01	Female Rod End, Left Hand M12 Thread, 1.75mm Pitch, M12 Ball ID	1

Super Alpine Racer - Platform Mechanism Assembly



ITEM NO.	PART NUMBER	DESCRIPTION	QTY.
1	603-00543-01	5-Hole Tread Plastic	1
2	500-00071-01	24CM Blue LED "Great Wall" Rope	1

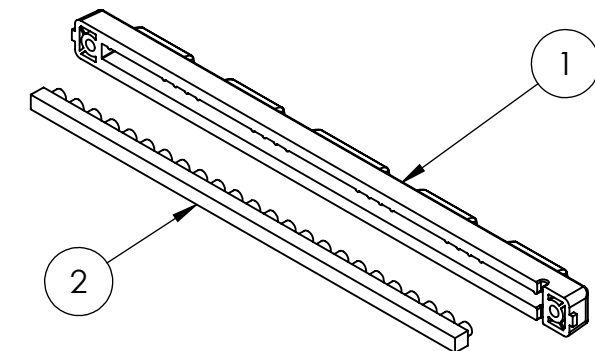

Super Alpine Racer - Pedestal Light Assembly

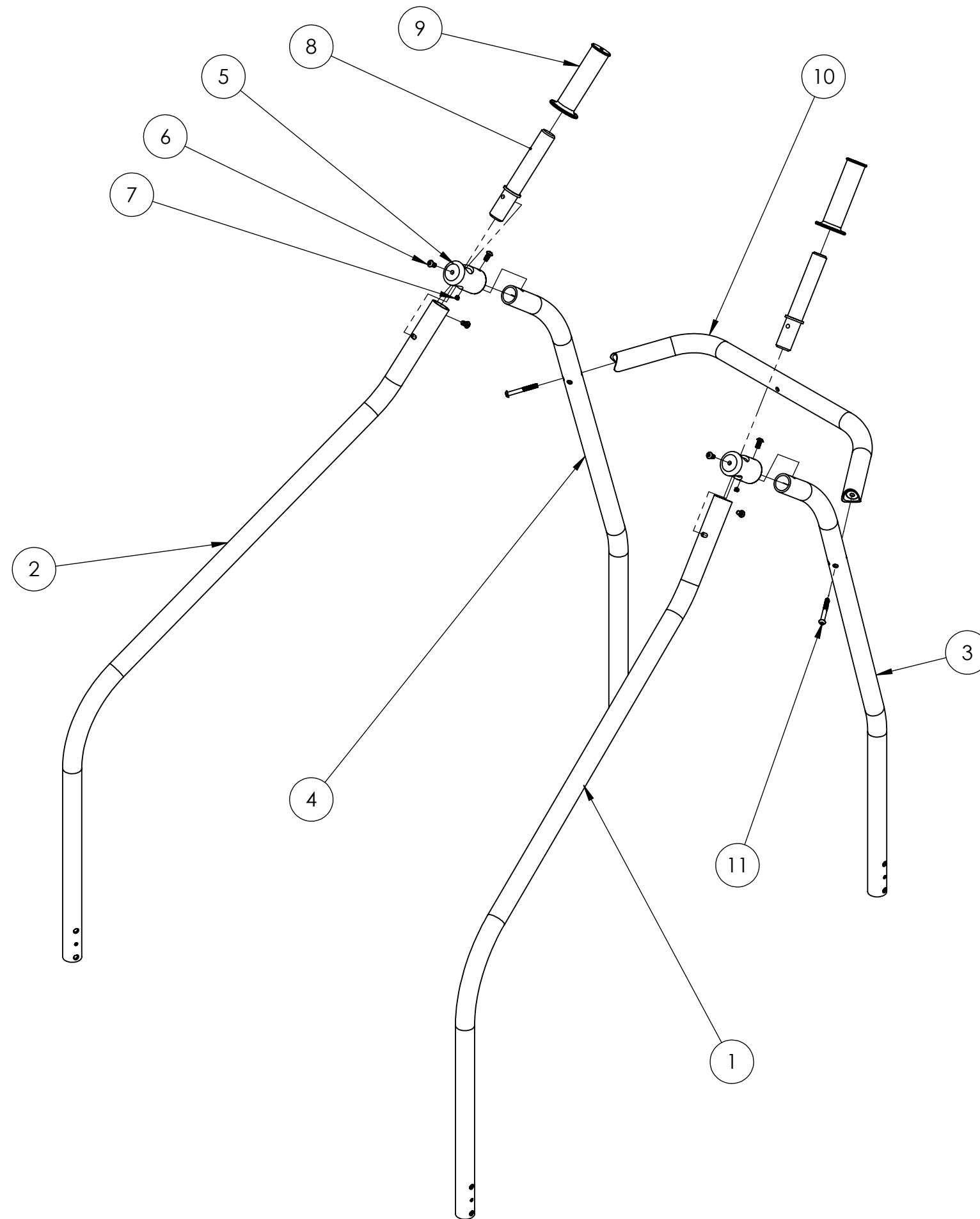

ITEM NO.	PART NUMBER	DESCRIPTION	QTY.
1	Front_Right_Ski_Pole_Assy	Front Right Ski Pole	1
2	Front_Left_Ski_Pole_Assy	Front Left Ski Pole	1
3	Rear_Right_Ski_Pole_Assy	Rear Right Ski Pole	1
4	Rear_Left_Ski_Pole_Assy	Rear Left Ski Pole	1
5	600-01178-01	Tube to Tube Connector	2
6	McMaster-Carr - 96075A211	Black Alloy Steel Pin-in Torx Button Socket Cap Screw, 1/4"-20 Thread, 1/2" Length	6
7	McMaster-Carr - 90778A401	High Hold Cone Point Type 316 Stainless Steel Set Screw, 1/4"-20 Thread, 1/4" Length	2
8	600-01179-01	Hand Grip Insert	2
9	600-01352-01	Hand Grip	2
10	600-01307-01	Cross Pole	1
11	McMaster-Carr - 91900A549	Stainless Steel Pin-in Torx Button Socket Cap Screw, 1/4"-20 Thread, 2" Length	2

Super Alpine Racer - Ski Poles



ITEM NO.	PART NUMBER	DESCRIPTION	QTY.
1	600-01189-01	Pot Bracket	1
2	301-00031-01	1K Potentiometer w/ Flat on Shaft	1
3	McMaster-Carr - 92313A105	Type 316 Stainless Steel Cup Point Set Screw, 4-40 Thread, 3/16" Long	1
4	600-00116-01	Small Drive Gear	1
5	600-01188-01	Idler Stud	1
6	McMaster-Carr - 91770A827	18-8 Stainless Steel Truss Head Phillips Machine Screw, 10-32 Thread, 3/8" Length	2
7	600-01161-01	Drive Gear	1

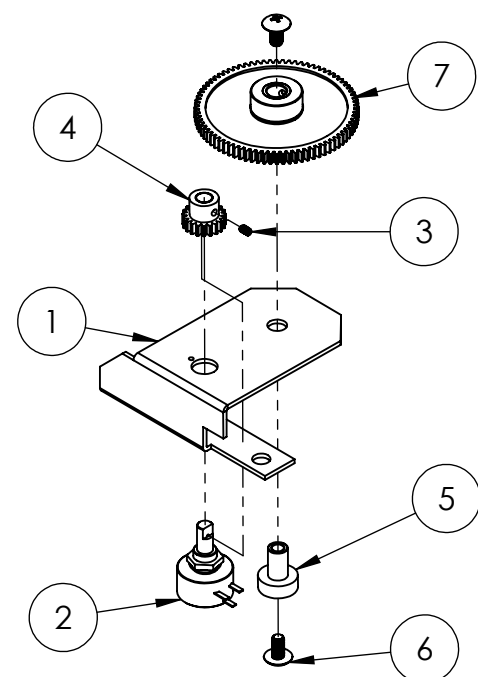

RAW THRILLS Super Alpine Racer Pot and Gear Assembly

ITEM NO.	PART NUMBER	DESCRIPTION	QTY.
1	600-01185-01	Rosta Plate	1
2	McMaster-Carr - 95649A247	UHMW Polyethylene Flat Washer, 5/8" Screw Size, 1.07" OD, .06" Thick	1
3	600-01298-01	Rosta: DR-S 18x80	1

RAW THRILLS Super Alpine Racer Rosta and Plate Assy

ITEM NO.	PART NUMBER	DESCRIPTION	QTY.
1	600-01353-01	Brake Pan	1
2	600-01195-01	Small Brake Bushing	1
3	604-00038-01	Electric Brake w/ 25mm Keyed Hub	1
4	600-01317-01	Machined Key: 8mm x 8mm x 20mm	1
5	600-01194-01	Large Brake Bushing	1
6	600-01186-01	Brake Bracket Assembly	1
7	McMaster-Carr - 91100A170	Zinc-Plated Steel Flat Washer, M10 Screw Size, 30mm OD, 2.5mm Thick	1
8	McMaster-Carr - 91290A522	Black Class 12.9 Alloy Steel Socket Head Cap Screw, M10 Thread, 1.5mm Pitch, 30mm Length	1
9	600-01161-01	Drive Gear	1
10	McMaster-Carr - 92313A192	Type 316 Stainless Steel Cup Point Set Screw, 8-32 Thread, 3/8" Length	1

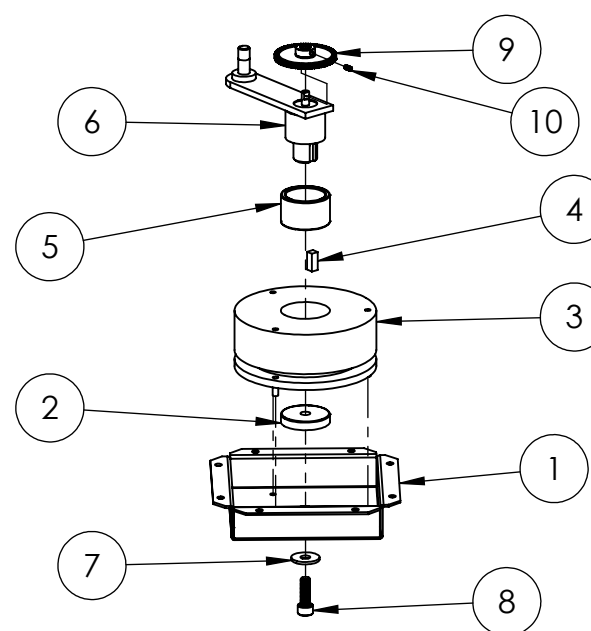

Super Alpine Racer Electric Brake Assy **RAW THRILLS**

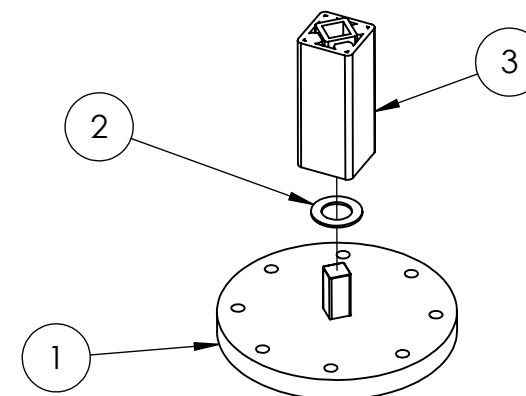

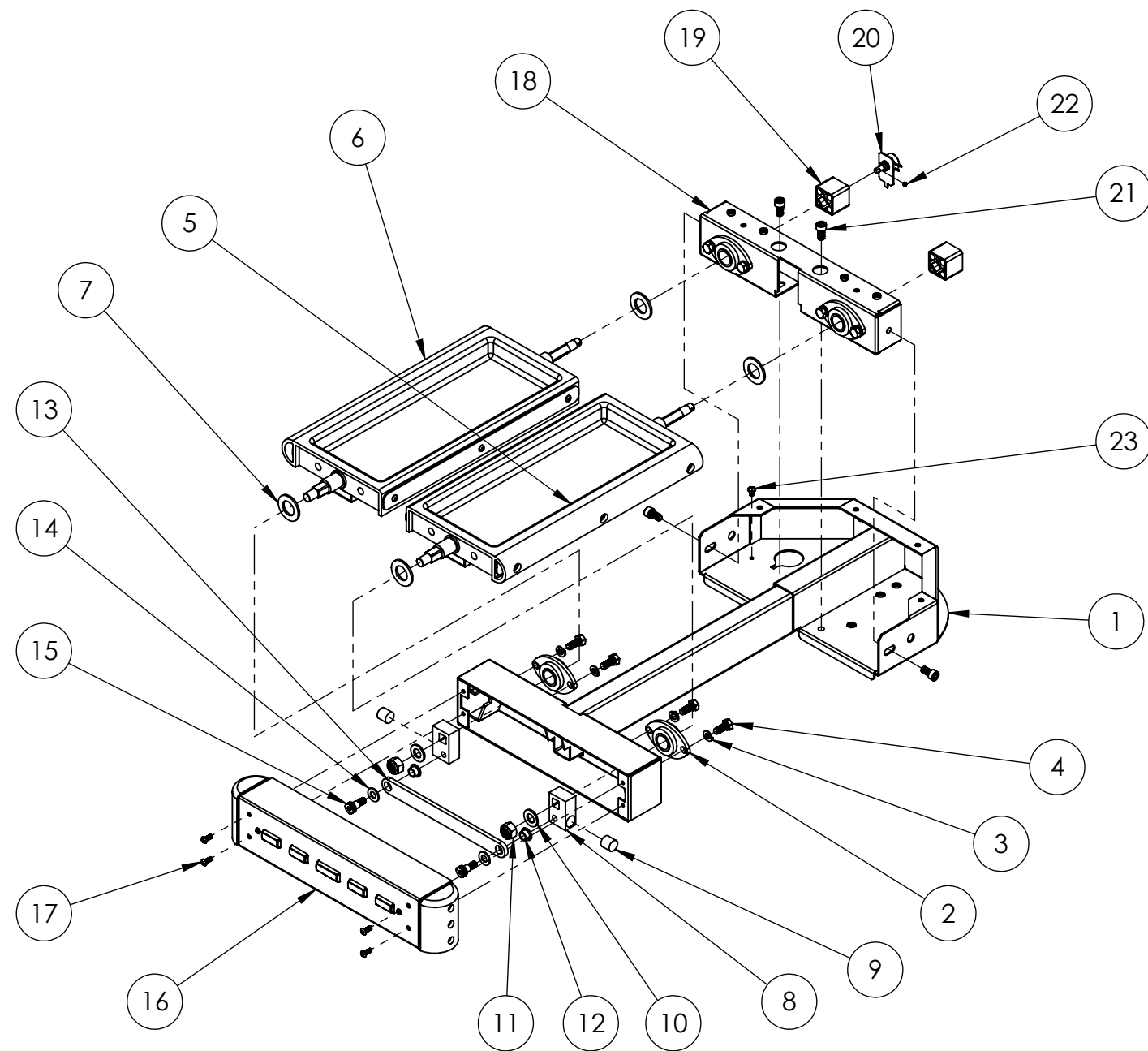

ITEM NO.	PART NUMBER	DESCRIPTION	QTY.
1	608-00173-01	Main Ski Bracket	1
2	600-01362-01	Spherical Bearing (Oiles 80FL-20)	2
3	McMaster-Carr - 91169A200	Black Steel Split Lock Washer, M8 Screw Size, 14.8mm OD, 1.9mm Thick	4
4	McMaster-Carr - 91310A533	High-Strength Uncoated Class 10.9 Steel Cap Screw, M8 Thread, 1.25mm Pitch, 20mm Length	4
5	Alpine_Step_Tray_Assy_Right	Right Step Tray Assembly	1
6	Alpine_Step_Tray_Assy_Left	Left Step Tray Assembly	1
7	McMaster-Carr - 91166A320	DIN 125 Zinc-Plated Class 4 Steel Flat Washer, M20 Screw Size, 37mm OD, 3mm Thick	4
8	600-01197-01	Link Connector Block	2
9	600-01215-01	Connector Block Bumper	2
10	McMaster-Carr - 91166A290	DIN 125 Zinc-Plated Class 4 Steel Flat Washer, M12 Screw Size, 24mm OD, 2.5mm Thick	2
11	McMaster-Carr - 90576A119	Zinc-Plated Class 8 Steel Nylon-Insert Locknut, M12 Thread, 1.75mm Pitch, 19mm Wide, 12mm High	2
12	McMaster-Carr - 7815K18	Alloy 932(SAE 660)Bronze Flanged-Sleeve Bearing for 3/8" Shaft Diameter, 1/2" OD, 1/4" Length	2
13	600-01198-01	Shoe Link	1
14	McMaster-Carr - 3750K2	Ultra-Tough Oil-Lube Bronze Thrust Bearing for 3/8" Shaft Diameter, 3/4" OD, 1/16" Thick	2
15	McMaster-Carr - 91259A617	Alloy Steel Shoulder Screw, 5/16-18 Thread, 1/2" Thread Length, 3/8" Shoulder Diameter, 3/8" Shoulder Length, 9/16" Head Diameter, 1/4" Head Height	2
16	Alpine_Rear_Platform_Cover_Assy	Super Alpine Racer - Rear Platform Cover Assembly	1
17	McMaster-Carr - 96075A187	Black Alloy Steel Pin-In Torx Button Socket Cap Screw, 10-32 Thread, 1/2" Length	4
18	Alpine_Rosta_Mount_Assy	Super Alpine Racer - Ski Rosta Mounts	1
19	600-01299-01	Rosta: DR-S 18x30	2
20	Ski_Pot_Assy	Super Alpine Racer - Ski Pot Assembly	1
21	McMaster-Carr - 91290A418	Black Class 12.9 Alloy Steel Socket Head Cap Screw, M8 Thread, 1.25 Pitch, 16mm Length	4
22	McMaster-Carr - 93245A110	Alloy Steel Nonmarring Flat Point Socket Set Screw, M4 Thread, 0.7mm Pitch, 4mm Length	1
23	McMaster-Carr - 90272A826	Zinc-Plated Steel Pan Head Phillips Machine Screw, 10-32 Thread, 5/16" Length	1

ITEM NO.	PART NUMBER	DESCRIPTION	QTY.
1	600-01209-01	Rear Metal Cover	1
2	600-01315-01	Rear Bumper	2
3	600-01316-01	Rear Bumper Anchor Plate	2
4	McMaster-Carr - 96075A187	Black Alloy Steel Pin-In Torx Button Socket Cap Screw, 10-32 Thread, 1/2" Length	6
5	Alpine_Platform_Light_Assy	Super Alpine Racer - Platform Light Assembly	1
6	McMaster-Carr - 96075A139	Black Alloy Steel Pin-in Torx Button Socket Cap Screw, 8-32 Thread, 1/2" Length	2

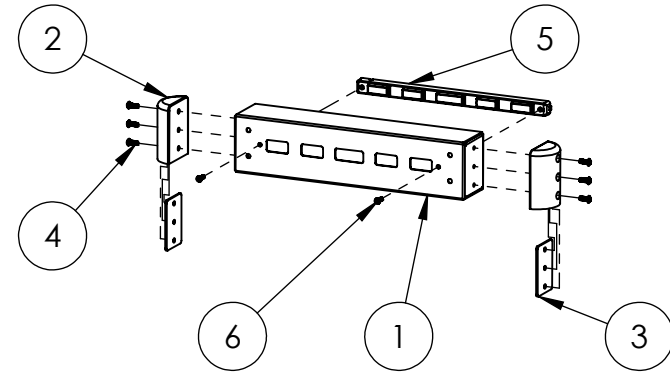

RAW THRILLS Super Alpine Racer Rear Platform Cover Assembly

ITEM NO.	PART NUMBER	DESCRIPTION	QTY.
1	600-01196-01	Ski Bracket Cap	1
2	600-01362-01	Spherical Bearing (Oiles 80FL-20)	2
3	McMaster-Carr - 91310A533	High-Strength Uncoated Class 10.9 Steel Cap Screw, M8 Thread, 1.25mm Pitch, 20mm Length	4
4	McMaster-Carr - 91169A200	Black Steel Split Lock Washer, M8 Screw Size, 14.8mm OD, 1.9mm Thick	4
5	600-01214-01	Rosta Mounting Bracket B	2
6	600-01213-01	Rosta Mounting Bracket A	2
7	McMaster-Carr - 93070A143	Low-Profile Class 8.8 Steel Socket Head Cap Screw, M6 Thread, 1mm Pitch, 12mm Length	4

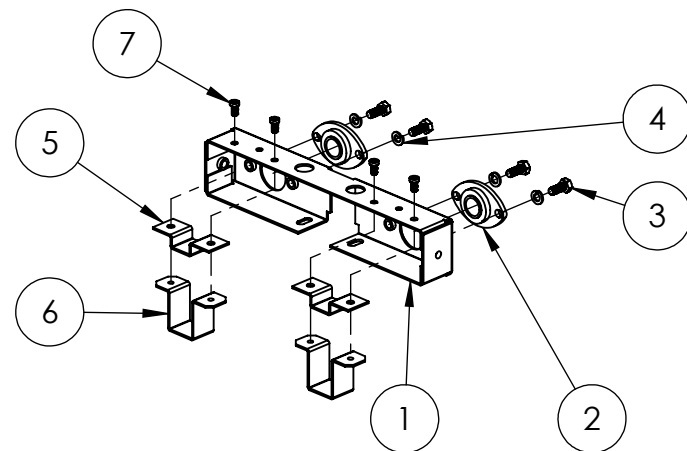

RAW THRILLS Super Alpine Racer Ski Rosta Mounts

ITEM NO.	PART NUMBER	DESCRIPTION	QTY.
1	603-00543-01	5-Hole Tread Plastic	1
2	500-00169-01	24CM Red LED "Great Wall" Rope	1

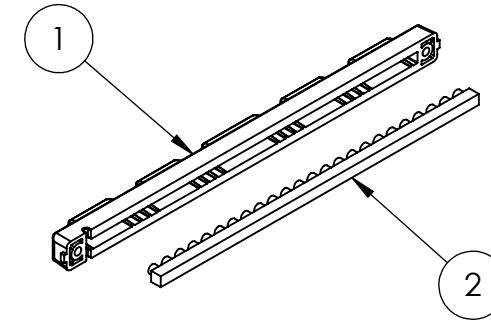

Super Alpine Racer Platform Light Assembly **RAW THRILLS**

ITEM NO.	PART NUMBER	DESCRIPTION	QTY.
1	600-01200-01	Pot Holder Bracket	1
2	301-00016-00	5K Potentiometer w/ Flat on Shaft	1

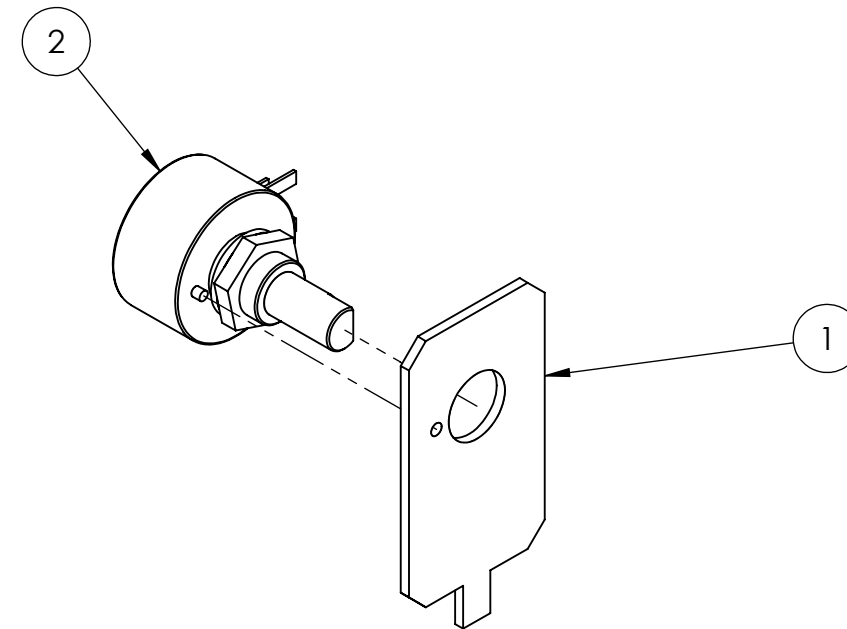

Super Alpine Racer Ski Pot Assembly **RAW THRILLS**

NOTES:

SUPER ALPINE RACER™ ©2014 NAMCO BANDAI Games Inc.