

# SUPER CHEXX™



## OWNERS AND SERVICE MANUAL INNOVATIVE CONCEPTS IN ENTERTAINMENT INC.



# **INNOVATIVE CONCEPTS IN ENTERTAINMENT, INC.**

**COPYRIGHT© 1983 BY INNOVATIVE CONCEPTS IN ENTERTAINMENT, INC.**

**ALL RIGHTS RESERVED**

No part of this publication may be reproduced by any mechanical, photographic, or electronic process, or in the form of a phonographic recording, nor may it be stored in a retrieval system, transmitted, or otherwise copied for public or private use, without the permission of the publisher.

The **SUPER CHEXX™** game play, all graphic designs, this technical manual, its accompanying schematic diagrams, and the trouble-shooting guide are protected by the new Copyright Act of 1976.

This Act provides for increased penalties for violating federal copyright laws. Courts CAN IMPOUND infringing articles while legal action is pending. If infringes are convicted, Courts can ORDER DESTRUCTION of the infringing articles.

In addition, the Act provides for payment of statutory damages of up to \$50,000.00 in certain cases. Infringes may also have to pay costs and attorneys' fees, fines up to \$25,000.00, and face an imprisonment of up to one year.

I.C.E. will aggressively enforce its copyrights against any infringes. WE WILL USE ALL LEGAL MEANS to immediately halt any manufacture, distribution or operation of a copy of any product made by us. Anyone who purchases such copies risks forfeiting such a game.

U.S.A and foreign patents pending.

Published By:

**INNOVATIVE CONCEPTS IN ENTERTAINMENT, INC.  
10123 MAIN STREET  
CLARENCE, NEW YORK 14031**

Sales: 716 759-0370

Service: 716 759-0360

Email: [service@icegame.com](mailto:service@icegame.com)

[www.icegame.com](http://www.icegame.com)

# TABLE OF CONTENTS

SUPER CHEXX™ Game Play.....	Page 4
Outstanding Features.....	Page 6 & 7
Programming.....	Page 8
Game Assembly.....	Page 9
Game Operation—Test.....	Page 9
Maintenance.....	Page 11 THRU 13
Troubleshooting and Repair.....	Page 14 THRU 18
Parts Listing.....	Page 19
Schematics & Wiring Diagrams.....	Page 20 THRU 26
Warranty Information.....	Page 27 & 28

# SUPER CHEXX™ GAME PLAY

The SUPER CHEXX™ Hockey game has been designed to resemble “real” hockey action. The object of the game is to out-score your opponent before time runs out. Goals can be scored, with the game continuing, until the “last puck in play” mode begins. When the last puck in play is scored, the game ends.\*

Example: If a score is 5-3, the last puck would result in a final score of 5-4 or 6-3.

\*The exception to this rule occurs when a final puck would create a tie score.

Example: If the score is 2-1, the last puck might make the score 2-2. The game then automatically goes into a “Sudden Death Overtime” mode and a final tie-breaking puck is ejected. The game will end when the tie-breaking goal is scored.

The National Anthem, as well as the “Boo” sound and the “Ooh’s” and “Aah’s” add to the excitement of playing SUPER CHEXX™. The “Boo” button can be used to eliminate the National Anthem or to “Boo” your opponent.



# FEATURES

SUPER CHEXX™ is a unique kinetic action hockey game, using state-of-the-art components, electronics, and advanced sound effects designed to closely resemble the action, play, and feel of a real ice hockey game.

## BREAK RESISTANT POLYCARBONATE DOME

The cover of this game is made of Lexan and will resist breaking or cracking.

## OVERHEAD SCOREBOARD

Scores and shots on goal are automatically tabulated by the main processor unit and displayed here. Other features include a running time clock, digital period display, and a fluorescent light that produces minimal heat eliminating the need for a fan.

## UNIQUE SOUND EFFECTS

The sound effects in this game use state-of-the-art components. Along with synthesized organ chants, this game utilizes natural sounds actually recorded at a real hockey game. Cheers can be noted when a goal is scored. "Oh" sounds are produced when a puck enters the goalie's crease. Organ chants indicate period changes, last puck in play mode, and sudden death overtime. A player can actually "Boo" his opponent by pressing the "Boo" button located at each end of the cabinet. Added to all these sounds are a full-time background noise and a National Anthem at the beginning of each game. A player can even bypass the anthem if desired by pressing the "Boo" button.

## GEAR / CLUTCH DESIGN

Each player on the game rotates on a 2.4:1 gear mechanism, which utilizes a built-in clutch to allow opposing players to strike or check one another without causing damage to components. This feature also eliminates intentional abuse. The gearing mechanism has been designed to allow a player to rotate at maximum speed with a minimum of effort.



## CENTER ICE FACE OFF

This hockey game has a center ice face-off feature to add to the realism of play. The puck is automatically ejected once at the beginning of the game and once after each goal. The puck may be ejected manually by pressing the Boo/Eject buttons.

## NEW ROD MATERIAL

Unlike previous games using rods that bend or break easily, SUPER CHEXX™ uses rods with a specially developed fiberglass composite and exterior coating to eliminate previous problems. These rods are immune to even torturous abuse. They can bend almost 90 degrees and still return straight time after time.

## PLAYERS



LONG STICK PLAYER - 1 PER TEAM



SHORT STICK PLAYER - 4 PER TEAM



GOALIE - 1 PER TEAM

SUPER CHEXX™ has realistic three-dimensional decorated players to even further enhance realism and enjoyment of the game.

# FEATURES

## GAME CABINET

The cabinet is of unitized construction using high quality aluminum for strength, durability, and reliability. Threaded inserts are used throughout the cabinet to make removal and installation of parts in the cabinet fast and easy.

## GAME BASE

The base design is a first in the game industry, using a one-piece high impact plastic material versus conventional wood or particleboard cabinetry. It is impervious to liquid spills as well as many other typical abuses to which games are subjected. The coloring has been molded into and throughout the base, eliminating the effect of scratches that harm the appearance and beauty of the game.

## ADJUSTABLE TIME AND VEND PRICE

The time and vend price of the game can be adjusted individually by switches on the main PC board. Time can be set for two, three, four, or five minutes. The vend price can be adjusted for \$.25, \$.50, \$.75 or Free Play. Any combination of time and price can be used.

## ELECTRONICS ACCESS

All of the SUPER CHEXX™ electronics are located on a single PC board just inside the coin door. All IC's are readily accessible and mounted in high quality sockets simplifying repairs.

## SCOREBOARD ELECTRONICS

The scoreboard electronics, designed with state-of-the-art circuitry, are very reliable. If any repair should be necessary, the scoreboard can be replaced in less than (5) minutes, eliminating costly down time.

## SPEED OF PLAY

The play of the game is extremely fast. A unique ramp construction eliminates dead spots and a special finish on the highly polished playfield enhances the puck action. The gearing ratio (described earlier), used for fast and effortless play and rotation, provides for greater speed and accuracy when shooting the puck.

## QUICK ASSEMBLY

The game, designed in two pieces with an upper and a lower half, can be assembled and connected in less than (5) minutes.

## OVER / UNDER COIN DOOR

An industry standard over / under coin door is used in the SUPER CHEXX™ game.

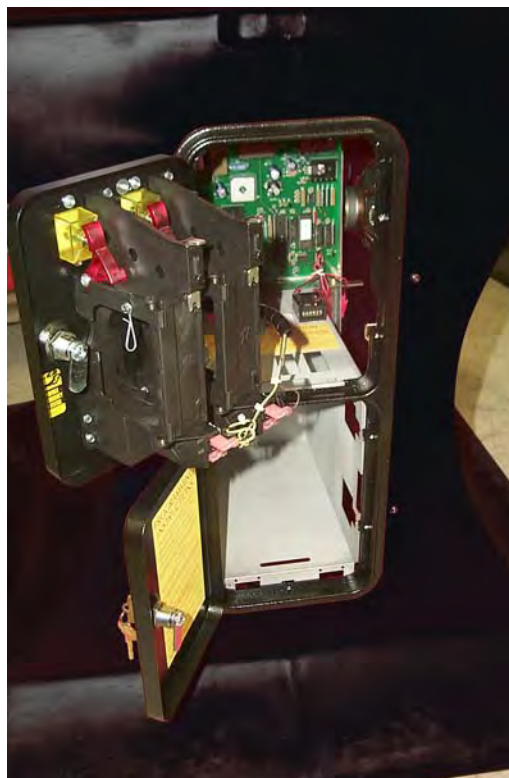

# PROGRAMMING INSTRUCTIONS

- PRESS THE PROGRAM (PGM) BUTTON OF THE MAIN P.C. BOARD. (THIS IS THE LEFTMOST OF THE 4 BUTTONS).
- PRESS THE SELECT (SEL) BUTTON TO ADVANCE THROUGH THE VARIOUS PROGRAMMING OPTIONS.
- PRESS THE STEP (STEP) BUTTON TO CHANGE THE VALUE OF THAT PARTICULAR PROGRAMMING OPTION.
- WHEN FINISHED, PRESS THE PROGRAM (PGM) BUTTON TO RETURN TO GAME PLAY MODE.

NOTE: PRESSING THE START BUTTON WILL PLAY 1 GAME WITHOUT ADVANCING ANY COUNTERS. (OR DISPENSING ANY TICKETS FROM THE OPTIONAL TICKET DISPENSER)

## GAME OPTIONS

1. **COIN 1 (COINS PER CREDIT)** SET THIS VALUE FOR HOW MANY COINS IT WILL TAKE FOR 1 CREDIT.
2. **COIN 2 (COIN 1 EQUIVALENT)** SET THIS VALUE TO 1 IF YOU WISH THE VALUE TO BE THE SAME AS COIN 1 (IF YOU WISH THE VALUE TO BE TWICE AS HIGH, SET TO 2. IF YOU WISH THE VALUE TO BE THREE TIMES AS HIGH, SET TO 3, ETC...).
3. **TIME UNITS PER PERIOD** SET THIS VALUE TO 20 FOR HOCKEY, OR 15 OR 30 FOR SOCCER.
4. **TIME PER PERIOD** SET THIS NUMBER FOR THE ACTUAL AMOUNT OF SECONDS PER PERIOD. MULTIPLY THE NUMBER OF PERIODS BY THE NUMBER OF SECONDS YOU CHOOSE FOR OVERALL GAME TIME. EXAMPLE: 60 SECONDS X 3 PERIODS (HOCKEY) – 3 MINUTE GAMES.
5. **NUMBER OF PERIODS** SET THIS NUMBER TO 3 FOR HOCKEY, OR 2 OR 4 FOR SOCCER.
6. **ANTHEM** SET THIS VALUE TO 1 FOR THE CANADIAN ANTHEM, OR 0 FOR THE U.S.A. ANTHEM.
7. **AWARDS PER GAME** SET THIS VALUE FOR THE NUMBER OF TICKETS YOU WANT DISPENSED AT THE END OF THE GAME.
8. **ATTRACT MODE INTERVAL** SET THIS NUMBER FOR THE AMOUNT OF TIME BETWEEN ATTRACT MODE SOUNDS. SELECTING 0 WILL TURN THE ATTRACT MODE OFF.
9. **PUCK EJECT STRENGTH** ADJUSTABLE FROM 5 TO 15. DEFAULT IS 10.

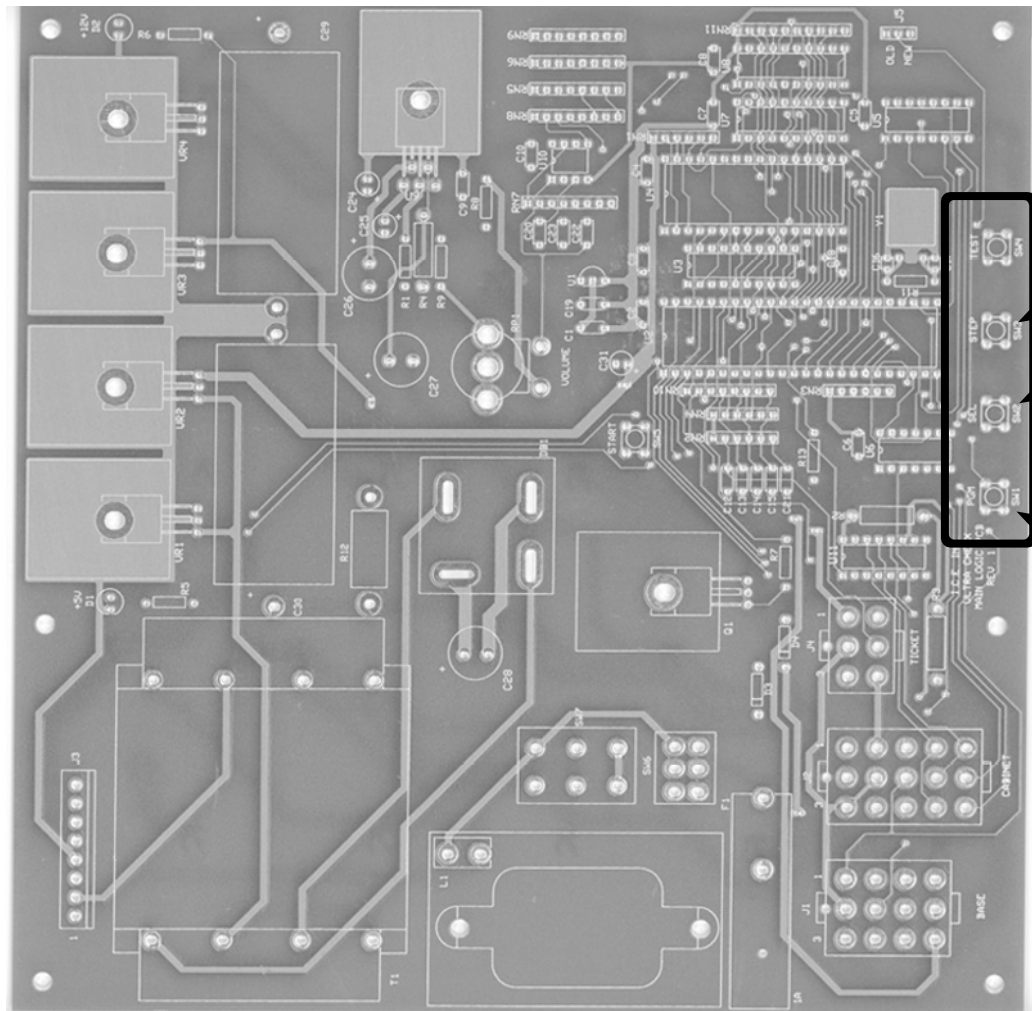



# GAME ASSEMBLY

These steps should be followed for initial installation as well as any time the game is dismantled and moved to a new location.

## INSPECT INSIDE OF BASE

1. Check for loose parts or foreign material in bottom.

Inspect harnessing to speakers, coin door and coin meter.

Inspect main PC Board for damage and familiarize yourself with the 15-pin cabinet harness connector and the 8-pin header for the scoreboard ribbon cable.

2. Place cabinet on Base oriented with hinge side of cabinet opposite the coin door side of the Base.

Align the two so that the threaded cabinet mounting inserts are visible through the access holes and the mounting holes in the Base.

Install 4 Allen Head mounting bolts with fender washers and tighten with supplied T-handle wrench. Install the first bolt and tighten slightly. The remaining bolts may now be installed. The cabinet may have to be shifted so that the holes in the Base line up with the threaded inserts in the cabinet. Tighten all bolts securely.

3. Connect 15-Pin Connector and Ribbon Cable connector to main PC Board. **The locking edge of the ribbon cable connector should face the rear of the base. Do not force or connect backwards or damage will occur.**

Connect the loose ground wire to the open ground terminal on the top of the cash box.

4. Plug game into 110 (optional 220) volt GROUNDED AC outlet and turn on PC Board mounted power switch.

**Warning:** Failure to use a 3-prong grounded outlet will void your warranty and may cause harm to the game, yourself, and others.

5. Coin-up game and check for proper operation.
6. Finally, make sure your game is clean. A clean game looks good, gets more play, and makes more money than a dirty game.

# GAME OPERATION - TEST

**IMPORTANT: IF THE GAME FAILS TO PERFORM THE FOLLOWING TESTS AS DESCRIBED, REFER TO THE TROUBLESHOOTING SECTION.**

1. Before starting a game, check to see that all players rotate smoothly and that all rods move in and out freely.

**NOTE: THE GEAR BOXES REQUIRE 10 - 20 GAMES TO FULLY BREAK IN. SLIGHT RESISTANCE WHEN ROTATING THE PLAYERS ON A NEW GAME IS NORMAL.**

2. Insert the proper number of coins to start game. The National Anthem will begin and upon completion, the puck will eject from the ejector chute. Shoot the puck in each net several times to ensure proper operation of the ejector.
3. Each time the puck enters the net; the score indicators on both sides of the scoreboard should indicate the goal scored. Continue scoring until the game ends, checking the score indicators for proper operation. Check to see that the score

indicators on both sides of the scoreboard are working correctly.

4. Restart the game. Press the Boo/Eject button to ensure the National Anthem is bypassed. The puck should eject.
5. After the puck ejects, press the Boo/Eject buttons on both ends of the game to ensure the "Boo" sound is heard and eject Solenoid is activated.
6. Run the puck through each goal crease. The "Oh" sound should be heard as the puck passes through the crease. Note that a shot on a goal has been registered.

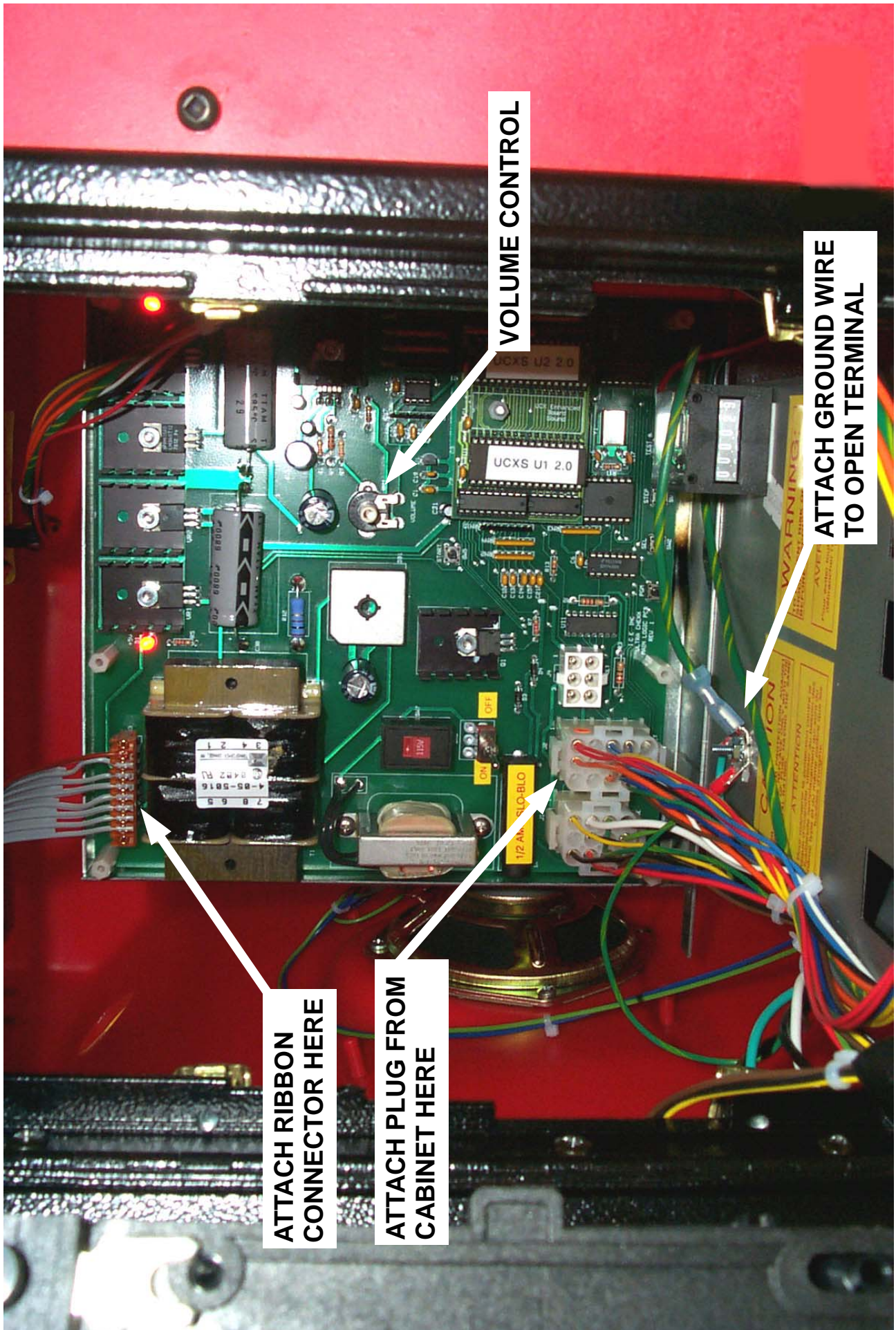

**ATTACH RIBBON  
CONNECTOR HERE**

**ATTACH PLUG FROM  
CABINET HERE**

**VOLUME CONTROL**

**ATTACH GROUND WIRE  
TO OPEN TERMINAL**

# MAINTENANCE

All parts in the SUPER CHEXX™ Hockey Game have been manufactured to the highest standards possible. The following maintenance should be performed as recommended to assure optimal performance and longevity of the game.

**WARNING: THIS GAME DOES NOT REQUIRE ANY LUBRICATION. USE OF ANY OILS OR GREASE MAY VOID YOUR WARRANTY.**

Most mechanical maintenance jobs, when required, will necessitate removal of the dome and / or ice surface. In all cases, when the ice surface must be removed, follow the ice surface removal procedure as given.

## PARTS KIT

Included in the spare parts kit, is a wire cable with loop & hooks. This is used to hold the dome open when tilted back to service the game.

In the event the goalies are removed, extra cotter pins are provided if the original cotter pins are damaged or lost.

## PUCK

Inspect the puck for large gashes, which may impede a smooth rolling action down the puck ramps. Replace if necessary.

## PUCK RAMPS

Periodically check the puck ramps for dirt accumulation and / or other objects or materials that may cause the puck action to slow down. To clean the ramps, remove the goalies. Slide all players to center ice (this saves time, as all the players and ice surface do not have to be removed). Bend up the ice on either end and remove the nets. Clean out the tracks and reassemble.

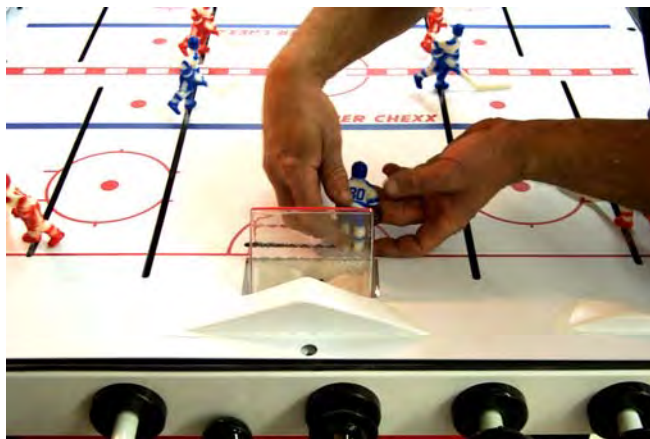

## SCOREBOARD LIGHTS

Replacement is advised when necessary. Remove the four screws on the light diffuser and pull out the bulb. Insert the new bulb and reassemble.

**NOTE: TIE WRAPS HAVE BEEN USED TO SECURE THE FLOURESCENT LIGHT AGAINST SHIPPING DAMAGE AND ABUSE ON LOCATION. IT IS RECOMMENDED THAT THESE BE REPLACED AFTER A NEW LIGHT IS INSTALLED.**

## COIN MECHANISMS

Mechanisms should be cleaned and adjusted when necessary. Follow the manufacturer's instructions on adjustment and maintenance.

## PLAYER WASHERS

These washers, located over each gearbox, serve to keep the players shafts in place in their gearboxes.

Extreme care should be exercised when pulling out or pushing in players because a washer that falls into a track can be bothersome to remove. To help eliminate this problem, push all the rods all the way in, and pull the player straight out. When pushing a player back in, be sure the gearbox is lined up with the shafts. If not, slowly rotate the rod while pushing down on the player.

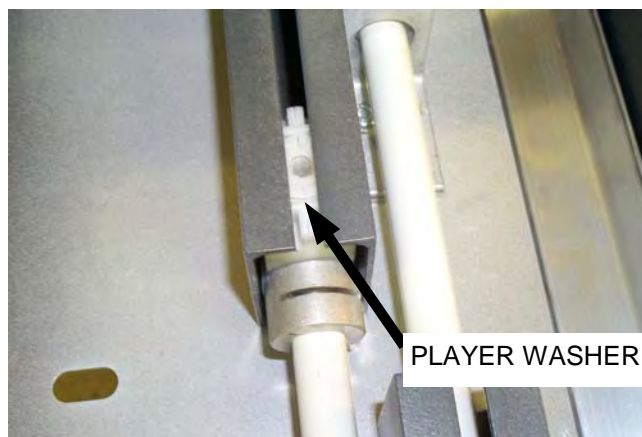

# MAINTENANCE



Start the game and observe operation. Check for foreign particles under the ejector arm. The entire bracket assembly can be repositioned to correct improper ejection in any direction. Loosen the 2 mounting screws and re-position as necessary. Be sure all parts work freely. Check by pushing the solenoid plunger only, to see that the ejector lifts up about 3/8" from the cabinet bottom. If less movement is noted, be sure that the ejector is not hitting any of the side chute areas or has become bent through failure of another part.

Excessive random angle ejections can be eliminated by centering the ejector in the vertical area of the chute. (An improperly positioned ice surface may also cause angled ejections) An ejector that sticks in the up or down position is due to either improper positioning, a broken spring or a damaged solenoid.

**NOTE: WASHERS SHOULD BE REPLACED WHEN WORN TO THE POINT THAT THEY CAN NO LONGER HOLD THE PLAYERS IN. AFTER PLAYERS ARE INSERTED, PULL UP GENTLY TO TEST THE STRENGTH OF THE WASHERS.**

## SOUND EFFECTS

Periodically test the sound effects, sensors, and the "Boo" button to ensure the proper functions. Test for National Anthem bypass.

## ICE SURFACE

The ice surface should be cleaned as needed, using Windex™, Fantastic™, or a comparable product. Apply liberally to a lint-free cloth, wipe surface thoroughly, and let dry. For a "faster" ice surface, dust lightly with Pledge™ and let dry.

## DOMES

The Lexan dome should be cleaned as needed, using a furniture polish type of cleaner. Apply to a lint-free cloth and wipe dome thoroughly.

**NOTE: PLEDGE™ IS RECOMMENDED. ALWAYS TEST THE CLEANER YOU INTEND TO USE ALONG THE FLANGE TO MAKE SURE THE CLEANER WILL NOT HARM THE DOME FINISH. TO REMOVE SCRATCHES, A SPECIAL SCRATCH REMOVER FORMULATED FOR LEXAN SHOULD BE OBTAINED.**

## PLAYERS

Periodically inspect the players for appearance or possible damage. Replace when necessary.

## EJECTOR MECHANISM

Periodically test the mechanism by scoring goal and observing puck ejection. If puck fails to eject, does not clear ice surface, the mechanism is not working correctly. Open the dome and remove the ice surface.

## NOTE:

**BE CAREFUL NOT TO LOSE THE FLAT WASHERS.**

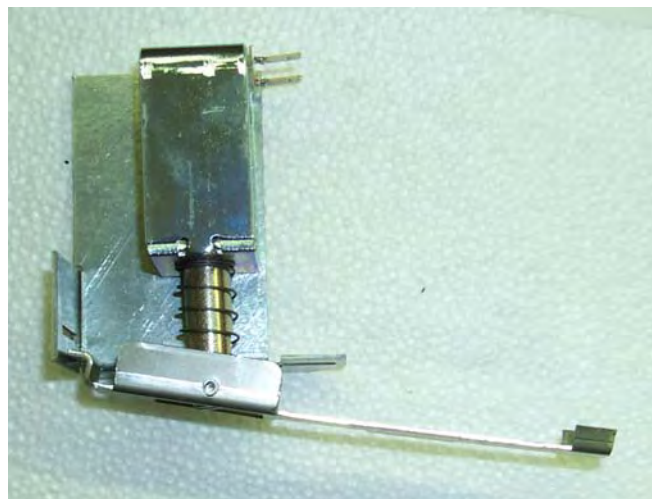
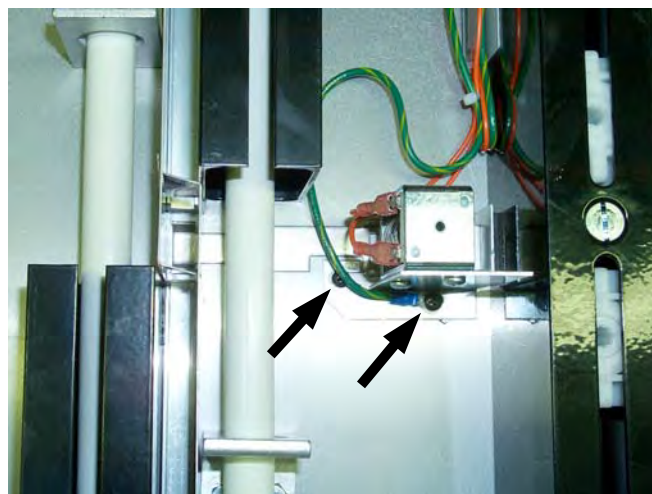

# MAINTENANCE

## GEARBOXES

Gearboxes should be inspected periodically to ensure smooth operation. Gearbox tracks should be kept as clean as possible. If a gearbox seems to rotate stiffly, first check to see that a rod collar is not pushed up tightly against it (this can happen if a grip comes off a rod and a gearbox hits a solid object, usually on defensemen). Back off a collar from a gearbox by loosening, moving, and retightening.

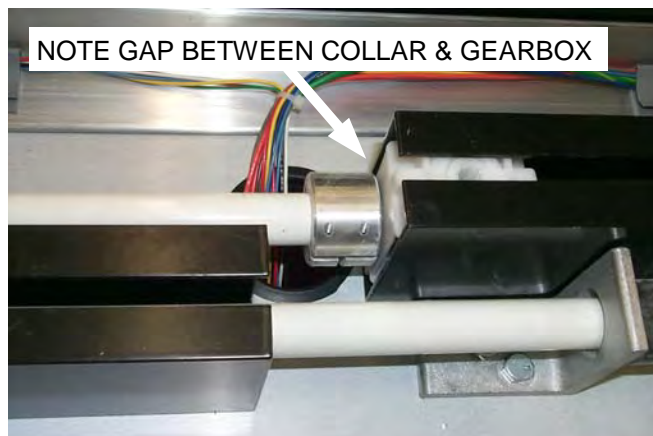

**NOTE GEARBOXES ARE LUBRICATED FOR LIFE AND SHOULD NOT BE OILED OR GREASED.**

## ROD BEARINGS

Check once a year for excessive wear. Replace when necessary.

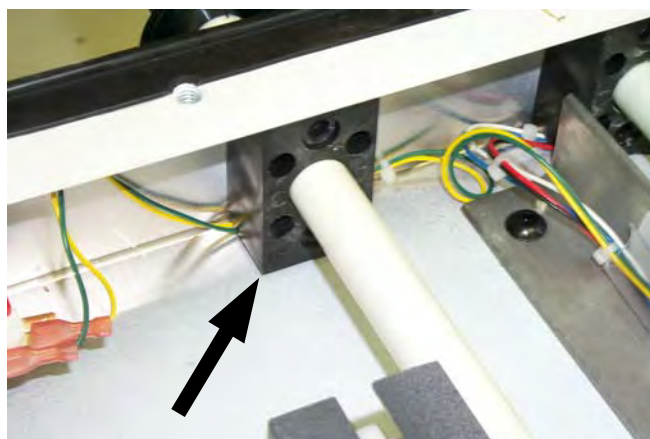

## PUCK CHUTE

Clean periodically to ensure a good sliding surface. Check for cracks. Small cracks can be glued with a C/A adhesive. Large cracks require changing the part.



## GOALIE MECHANISMS

Check for smooth operation.

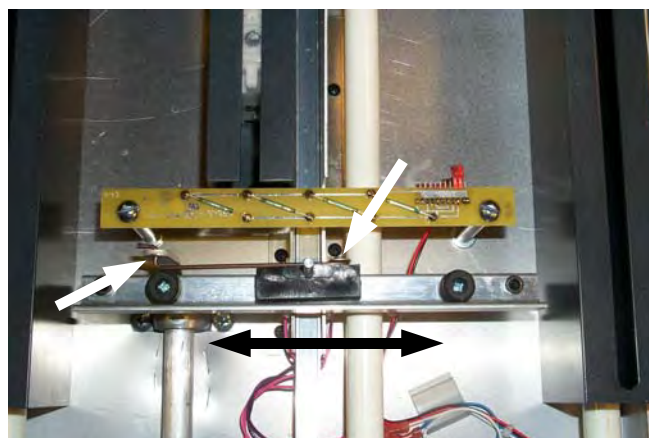

## RODS

Check periodically for cracks and gouges. Replace if necessary. Clean Mineral Spirits or Paint Thinner. Do not allow cleaner to contact the Dome, as it will damage the Dome.

## TRACKS

Check periodically. Clean by pushing a rag along the length of the track.

## SENSORS

These should be tested periodically by moving the puck over the "Oh" sensors and through the score sensors. Test a suspect sensor by unplugging and testing with ohmmeter. Replace if necessary.

# TROUBLESHOOTING AND REPAIR

## PUCK WILL NOT EJECT

For some ejection problems the ice surface may have to be removed.

1. Opening the dome and sliding all of the players to the center ice can correct dirt in the puck ramps. Next, remove the goalies one at a time, bend up the ice surface and clean the ramps. Assemble in the reverse order.
2. It is possible that the software (option #9) has been set up with the solenoid strength set too low. Enter the programming mode, go to option #9 and check the setting. The higher the value, the higher the puck will eject. Adjust the eject strength as necessary.

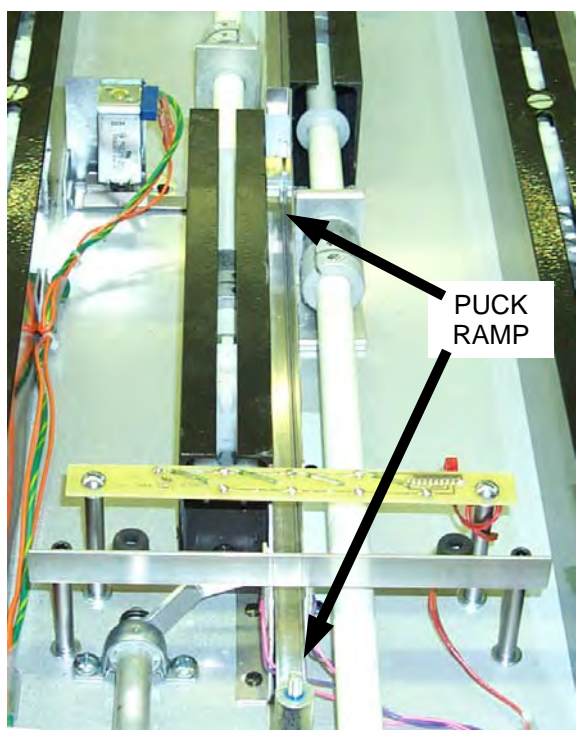

3. A puck ramp may become pushed up during shipping or moving. Just push it back down in the retainer/chute with a pencil or screwdriver.
4. A unique electronic circuit incorporated on the main PC Board prevents the eject solenoid from burning out. If a solenoid problem is suspected, check for a pulse of about 12 volts at the solenoid. Then remove the wires to the solenoid and check that the coil is not open or shorted. A good solenoid will read between 3-4 ohms.

**NOTE: REPLACE THE SOLENOID ONLY AFTER DETERMINING WITH AN OHM/VOLT METER THAT THE SOLENOID WAS RECEIVING POWER.**

## PUCK TAKES TWO OR THREE TIMES TO EJECT

1. A puck hitting the ice surface can be corrected by first making sure the ice surface is in place. If it is in place, observe which way the playfield is positioned. The opening can be centered by either bending the pins that locate the nets and ice surface from goal to goal, or bending the puck return chutes underneath for side-to-side adjustment.

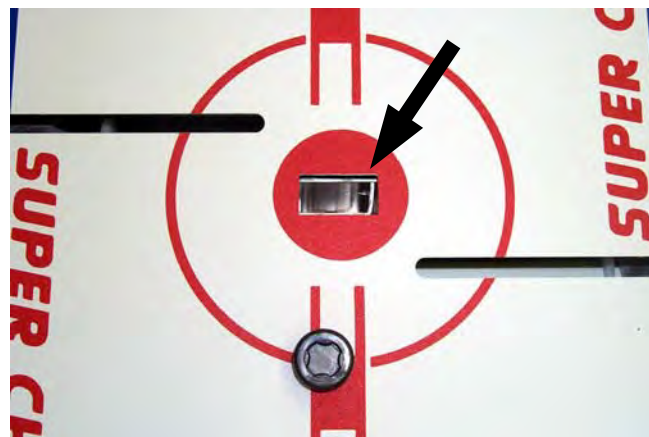

2. To determine if the ejector is misaligned, first remove the ice surface and then start the game. Look straight down the ejector chute and observe how the puck ejects. If the puck consistently hits one side of the chute, the ejector should be adjusted. Loosen the 2 screws that mount the solenoid assembly to the cabinet. Re-position the assembly so that the cup where the puck sits is centered into the vertical area of the chute.

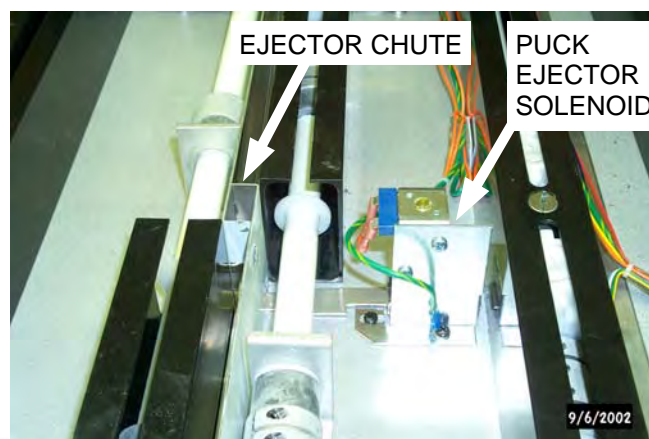

# TROUBLESHOOTING AND REPAIR

## GEARBOX IS DIFFICULT TO TURN

1. A gearbox-coupling collar may have been forced against a gearbox causing uneven or difficult turning. The usual cause for this is a handle grip coming off a rod and allowing the gearbox to hit either another gearbox or a cabinet end. To repair, simply loosen the collar and back it away from the gearbox between 1/32" and 1/16". Retighten.
2. Gear teeth being stripped out will generally cause binding at certain points of rotation. This situation should not occur until many games have been played. However, to check for bad gears, first remove the gearbox from the game. Loosen the gearbox collar and slide out the gearbox. If teeth on gears are worn out, replace the gearbox.
3. A worn gear bearing can cause a gearbox to work improperly. If you suspect a gear problem, first remove the gearbox from the game. If no problems are visible, disassemble the gearbox. If a worn bearing is found, replace the gearbox.

## GAME LIGHTING DIM

1. The scoreboard bulb may be burned out. Open the dome and see if the bulb appears to be burned out while the game is plugged in. Unplug the game. Remove the screws holding the right diffuser in place. Replace the light bulb and reassemble.
2. Very low AC power will cause poor lighting. To test, use a voltmeter on the suspect line to determine voltage. A CHEXX™ game hooked up to a line with too many other games may experience this difficulty. Move the game to its own AC line if this problem is experienced.

## NO LIGHT IN GAME

1. The light bulb may be burned out. Open dome see if bulb is burned out. Replace if necessary.
2. A loose scoreboard connector is not likely to affect the bulb without affecting some other component in the scoreboard. However, make sure the connectors are firmly seated.

## PLAYERS RUN INTO THE END OF THEIR SLOTS

1. A rod collar slipping may cause a player to hit the end of a slot in an ice surface. Open the game and rotate the rod until you can see the rod and gearbox touch, through the slot in the collar. If the rod and the gearbox do not touch, loosen the

PLAYER ROD & GEAR BOX SHAFT MUST MEET IN CENTER OF COLLAR SLOT

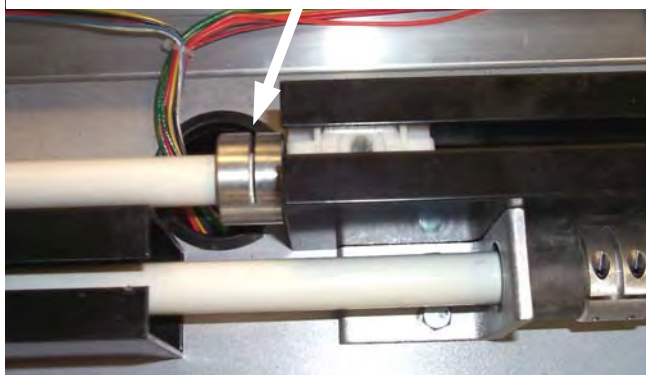

collar make sure the rod and gear box coupler touch, and retighten the gearbox. Be sure to leave 1/32" to 1/16" between the collar and the gearbox body.

## SCORE INDICATORS DO NOT WORK PROPERLY

1. A bad LED may cause malfunction. Replace the scoreboard and run electronic tests on the faulty unit.
2. A bad scoreboard chip may cause indicator malfunction. Replace the scoreboard and run electronic tests on the faulty unit.
3. A loose connection may cause malfunction. Check and repair as necessary.

## GAME LOSES PLAY SEQUENCE. GIVES FALSE SCORE, WILL NOT START WHEN MONEY IS INSERTED

1. Although game is protected against static electricity, an unusually large shock will cause the microprocessor to lose sequence. To correct the problem, turn off power and turn it back on to reset electronics.
2. A game plugged into an ungrounded outlet has no protection from static electricity. A large enough shock may destroy the IC chips. Electronic tests may be run to determine the fault. Repair as necessary.

## COINS NOT REGISTERED CORRECTLY

1. A bad micro-switch may be a problem due to internal failure. Test with an ohmmeter. Replace if necessary.
2. Loose connections may cause money to be registered improperly. Check the connectors from the coin mechanisms, as well as the connectors on the main PC Board. Repair if necessary.
3. A bad capacitor (CZ5) on the main PC Board may

# TROUBLESHOOTING AND REPAIR

cause bounce problems with the micro-switch. Run electronics tests to determine the problem.

## NO "OH" SOUNDS OR REPEATED "OH" SOUNDS

1. Short or open circuits in the harness or one of the reed switches on the "Oh" sensors are the most common problems. Repair as necessary.
2. A bad IC chip on the main PC Board may cause problems. Run electronics tests. Repair defective components.

## SCORE IS NOT REGISTERED-NO CHEER

1. A bad Reed Switch may cause a goal not to register. Disconnect and test with an ohmmeter. Replace if defective.
2. A bad connection could be a problem. Check associated harnessing and connectors with an ohmmeter.

## SCORE IS NOT REGISTERED-GAME CHEERS

1. A scoreboard connector may be loose or bad. Repair or correct as necessary.
2. A bad scoreboard IC chip may be a problem. Replace the scoreboard and run electronics tests to determine the problem.

## SCORE AND CHEERING KEEPS REPEATING FOR ONE TEAM WITH NO GOALS ACTUALLY BEING SCORED

1. A Reed Switch shorted to the cabinet will cause this problem. Usually an exposed wire touching the cabinet will be the cause of the problems.
2. A Reed Switch, always closed, can be tested by first disconnecting it from the board. Use an ohmmeter to see if the switch is always closed. If it is, replace the score Reed Switch.

## SOUND GOES LOW OR GOES ON AND OFF

1. Check the audio IC chips on the main PC Board. Replace any defective parts.
2. A faulty volume control is a possible cause for intermittent sound. Rotating the volume control will usually show a problem. Many times, the problem can be corrected by cleaning with a commercially available switch cleaner.
3. A bad speaker connection to the main PC Board may be the problem. Check and repair as necessary.

## PLAYERS RUB ON THE SIDES OF THEIR SLOTS

1. On rare occasions a track may become bent, forcing the player to work improperly. If, when the ice surface is properly located, you can see the top of an aluminum track, the track must be bent. Use a large screwdriver or other suitable object, and gently pry in the desired direction to obtain clearance. Check for smooth operation.

**NOTE: BE SURE NOT TO GOUGE THE SIDE OF THE CHANNEL WHEN PRYING. A RAG SHOULD BE WRAPPED AROUND YOUR SCREWDRIVER.**

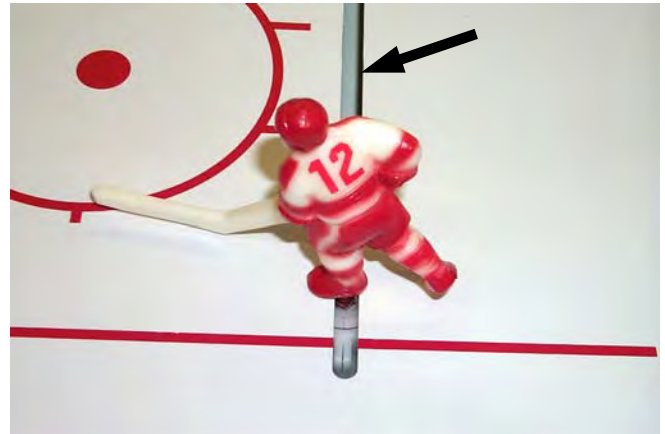

**NOTE: ALUMINUM TRACK IS NOT VISIBLE IN PHOTO.**



# TROUBLESHOOTING AND REPAIR

## TOP CABINET ASSEMBLY WITH ICE SURFACE & PLAYERS INSTALLED



### PLAYER NUMBERING AND LAYOUT

	<u>18 Long</u>		12 Short
	6 Short		<u>4 Short</u>
30 Goalie	<u>14 Short</u>	14 Short	<u>30 Goalie</u>
	4 Short		<u>6 Short</u>
	<u>12 Short</u>		18 Long

# TROUBLESHOOTING AND REPAIR

## TOP CABINET ASSEMBLY WITH ICE SURFACE & PLAYERS REMOVED

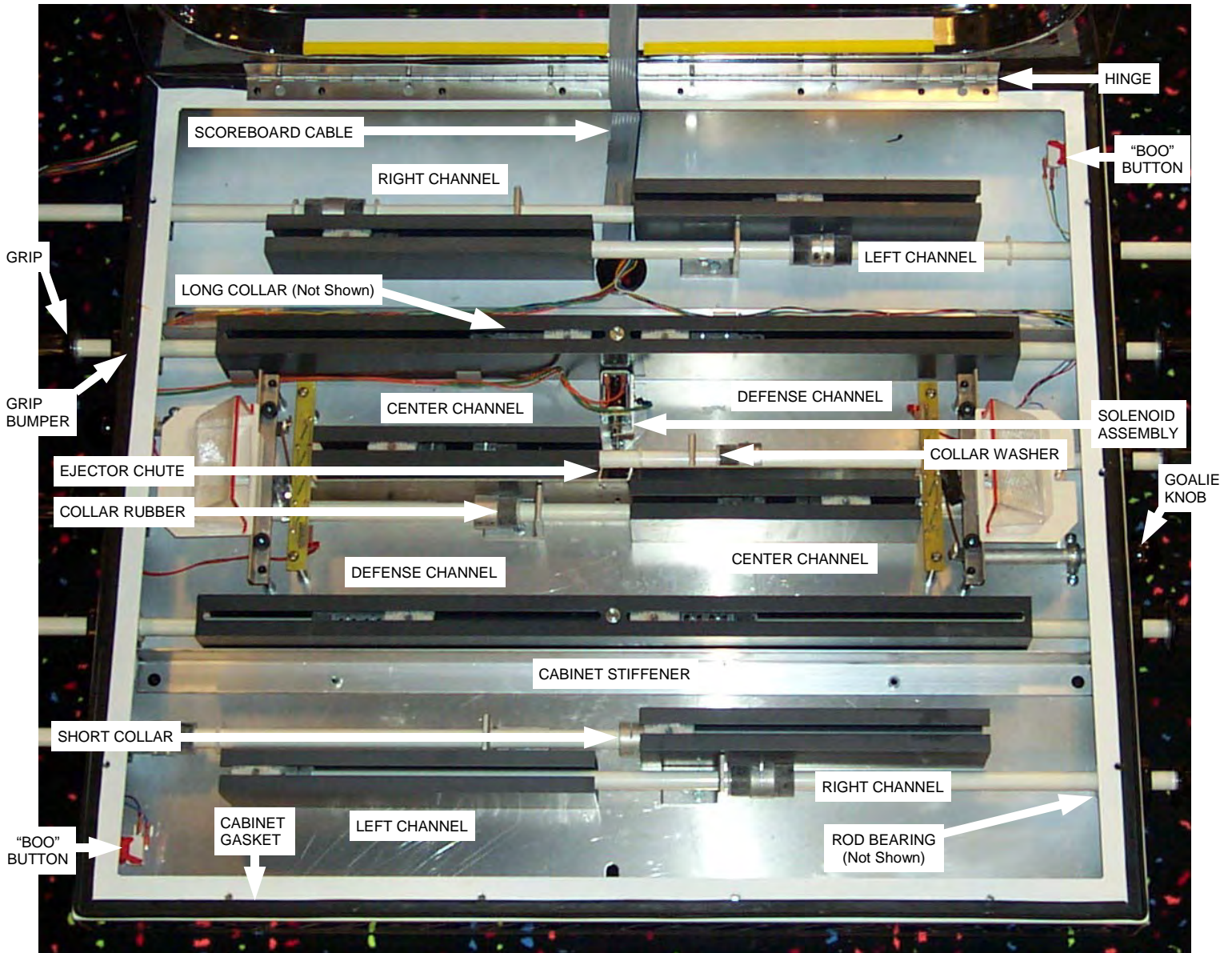

# PARTS LIST

745	DECAL (CABINET) (NEW STYLE)	3025X	ICE SURFACE ASSY.
1002X	ROD COLLAR (LONG)	3035	PLAYER ROD WASHERS
1003X	ROD COLLAR (SHORT)	3036	DOME WASHERS
1004X	GOALIE TRACK	4002	GOALIE BUMPER STOPS
1005	GOALIE SWING ARM	4003	CABINET GASKET PER PC. (10 FT.)
1007X	PLAYER TRACK 1 & 8 EACH	4004	COLLAR RUBBER
1008X	PLAYER TRACK 2 & 7 EACH	5003	SPEAKER GRILL
1009X	PLAYER TRACK 3 & 6 EACH	5105	EJECTOR ARM
1010X	PLAYER TRACK 4 & 5 EACH	5011	EJECT. SOLENOID SPRING
1112	CTR. EJECT RETAINER CHUTE	6001	DOME FASTENER
1013	PUCK RAMP ASSY.	6001B	DOME BOLT ALLEN WRENCH
1014	SCORE SENSOR BRACKET	6006	1/4 - 3/8 SHOULDER BOLT
1016	DOME HINGE	6010	GOAL. CLUTCH-O-RING
1018	GOALIE BEARING ASSY.	6011	GOAL. ROD WASHER
1019	CENTERMAN STOP	6024	DEFENSEMAN STANDOFF BOLT
1120	EJECT SOLENOID BRACKET	6025	VINYL STANDOFF TUBING
243X	DISPLAY PCBA	6036	COLLAR ALLEN WRENCH
248	PL 7 TRANSFORMER	6037	COLLAR SCREW
249	PL 7 BULB	6067	FENDER WASHER
250	PL 7 SOCKET	6076	COTTER PIN
2001	SCOREBOARD PCBB	6287	BASE TO CABINET BOLT 5/16-18 X 1 3/4
2003	BOO BUTTON	6706X	OH SENSOR ASSY. W/REED SWITCHES
2007	SPEAKER	6707X	SCORE/EJECT SENSOR ASSY.
2008	SOLENOID	6707A	1" REED SWITCH-SCORE/EJECT
SC2070X	MAIN PCBA	6711X	RIBBON CABLE ASSY.
2071	TRANSFORMER	7001X	GOALIE & BLOCK ASSY. WHITE/BLUE
2320	IC EPROM	7002X	GOALIE & BLOCK ASSY. WHITE/RED
2368	IC MICROPROCESSOR	7005A	PLAYER (LS/SC) WHITE/RED
341	SCOREBOARD HOUSING	7007B	PLAYER (LS/SC) WHITE/BLUE
342	SCOREBOARD COVER	7008A	PLAYER (SS/SC) WHITE /RED
3001	DOME	7010B	PLAYER (SS/SC) WHITE/BLUE
3002	CHUTE/NET ASSY.	7025B	DECAL (BOO/EJECT) BLACK
3002A	NET CURTAIN	7030X	CIGARETTE DECAL
3004	NET MOUNT TUBE (LONG)	7118	DECAL (BASE) (NEW STYLE)
3005	NET MOUNT TUBE (SHORT)		
3006	GOALIE BLOCK		
3007	GOALIE TRACK MNT. TUBE		
3008	PLAYER LOCK WASHERS		
3009	BUMPER STANDOFF		
3010A	GOALIE KNOB & ROD ONLY		
3010X	GOALIE ROD W / SWING ARM.		
3011	"D" FLECTOR		
3012X	GEARS		
3013X	PUCK ASSY.		
3016	ROD BEARING		
3017X	GRIP BUMPER ASSY.		
3018	NET RAMP		
3020	ROD GRIPS		
SK321	PLAYER ROD 1, 5, 6, 10 WINGERS		
SK322	PLAYER ROD 2, 4, 7, 9 DEFENSEMEN		
3024	PLAYER ROD 3, 8 CENTERMEN		

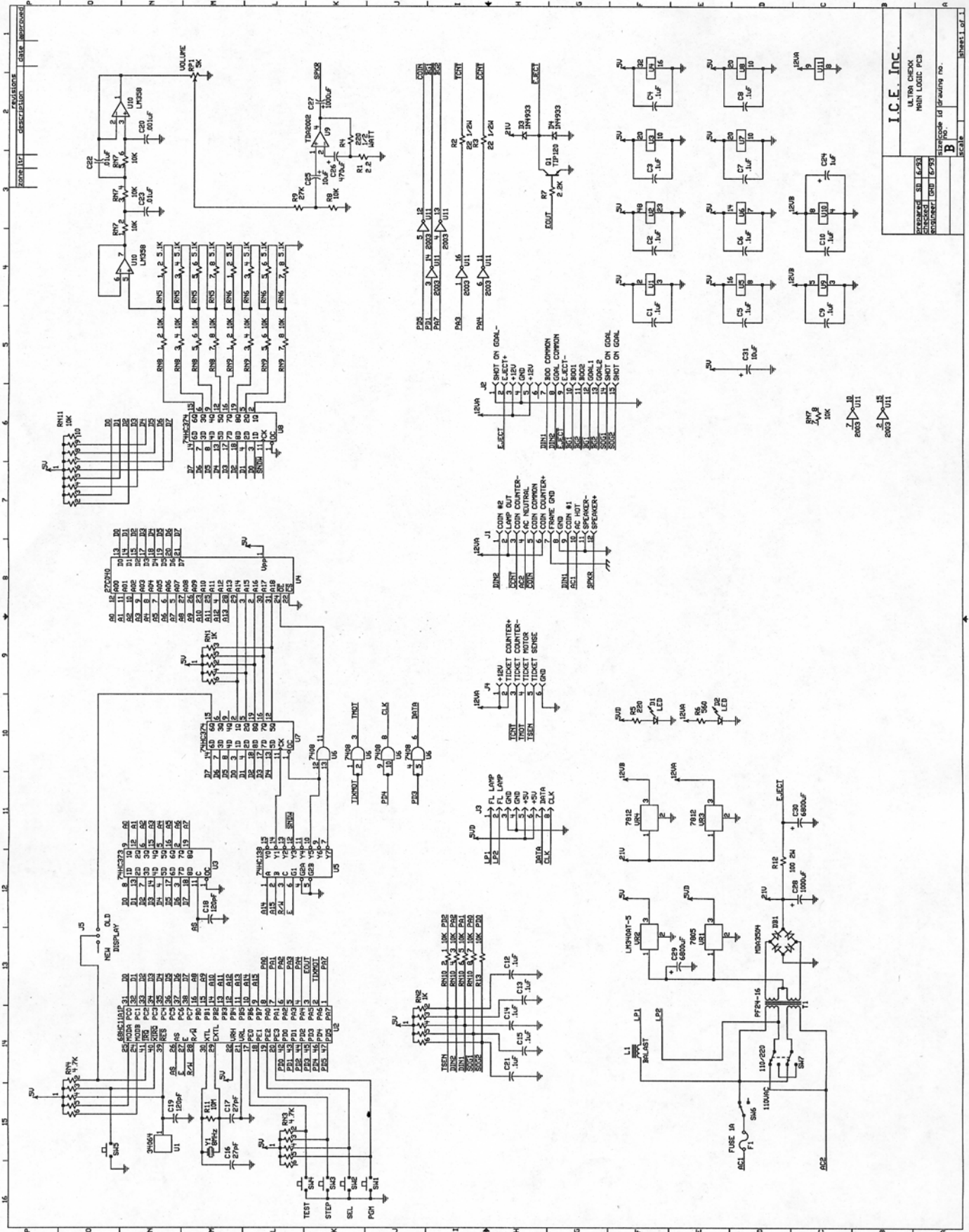

**IC.E. INC.**  
 ULTRA CHECK  
 MAIN LOGIC PCB  
 DRAWING NO. 16-93  
 REV. 10/93  
 QUANTITY 100  
 I.C.E. INC.  
 1000 W. 10th St.  
 St. Louis, MO 63103  
 (314) 431-1111

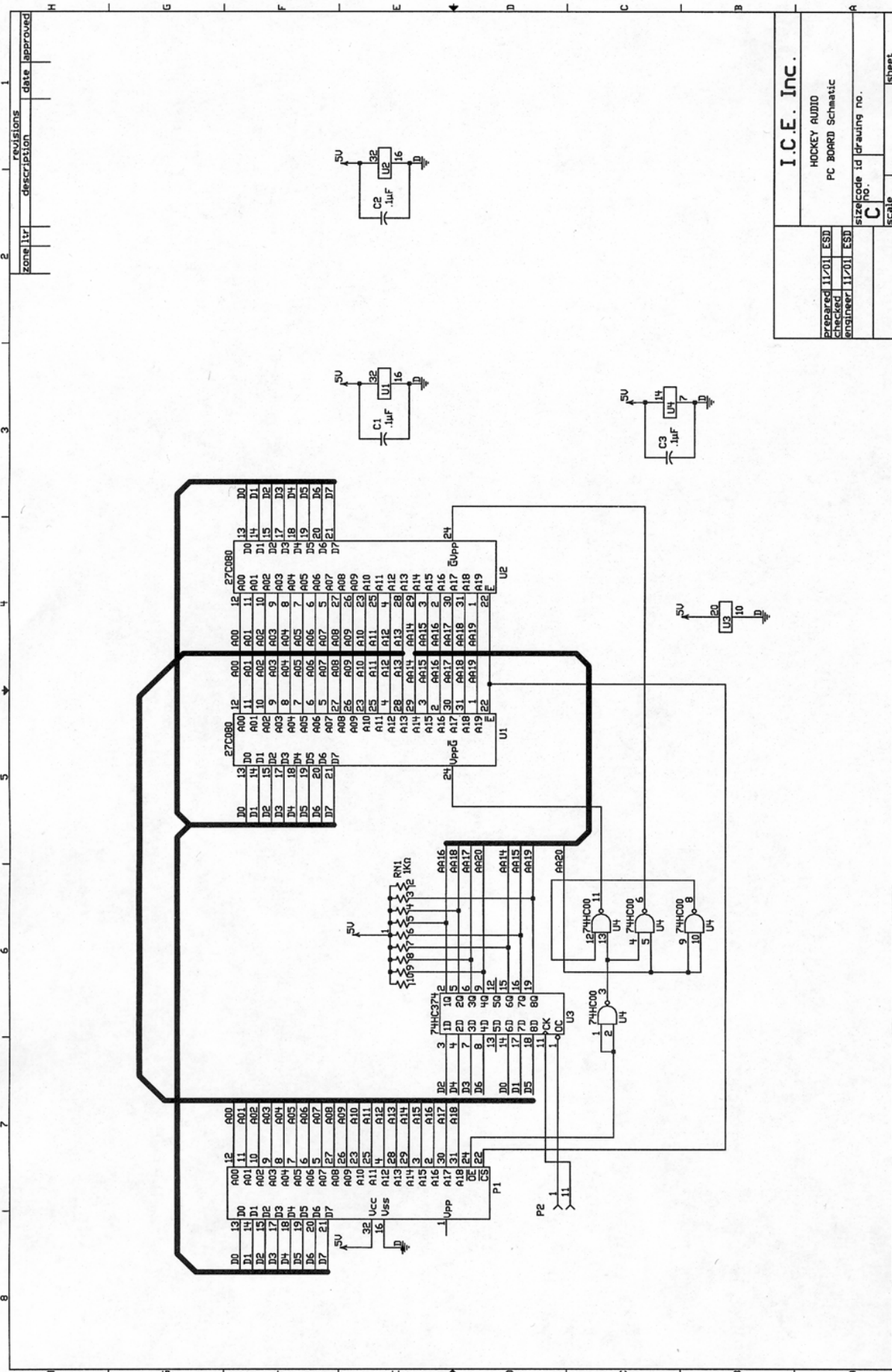

I.C.E. Inc.	
HOCKEY AUDIO	
PC BOARD Schematic	
Prepared	11/201 ESD
Checked	engineer
size/code	id drawing no.
C	
Scale	Sheet

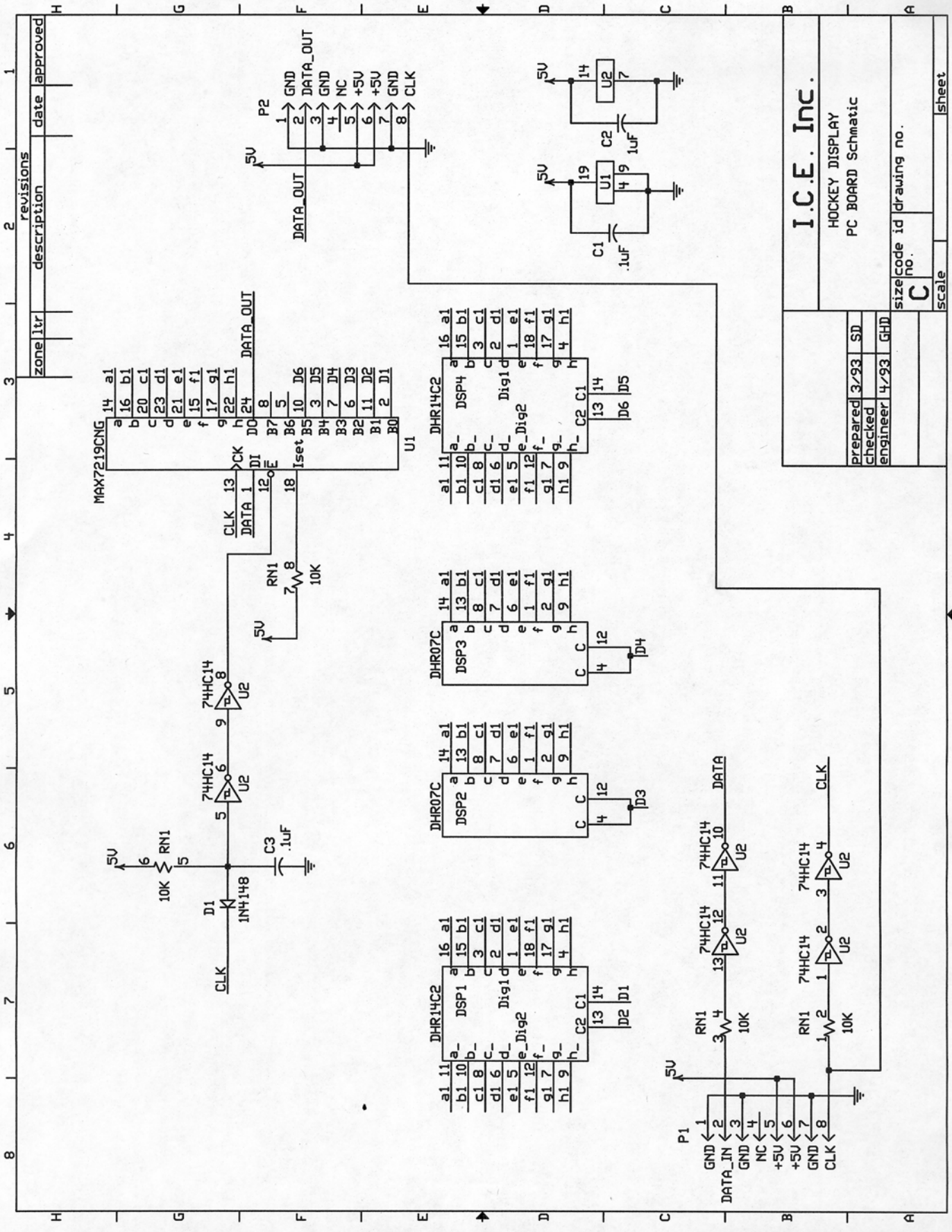

**I.C.E. Inc.**  
 HOCKEY DISPLAY  
 PC BOARD Schematic

prepared	3/93	SD
checked	4/93	GHD
engineer		

size code id drawing no. **C**  
 no. **C**  
 scale **C** sheet

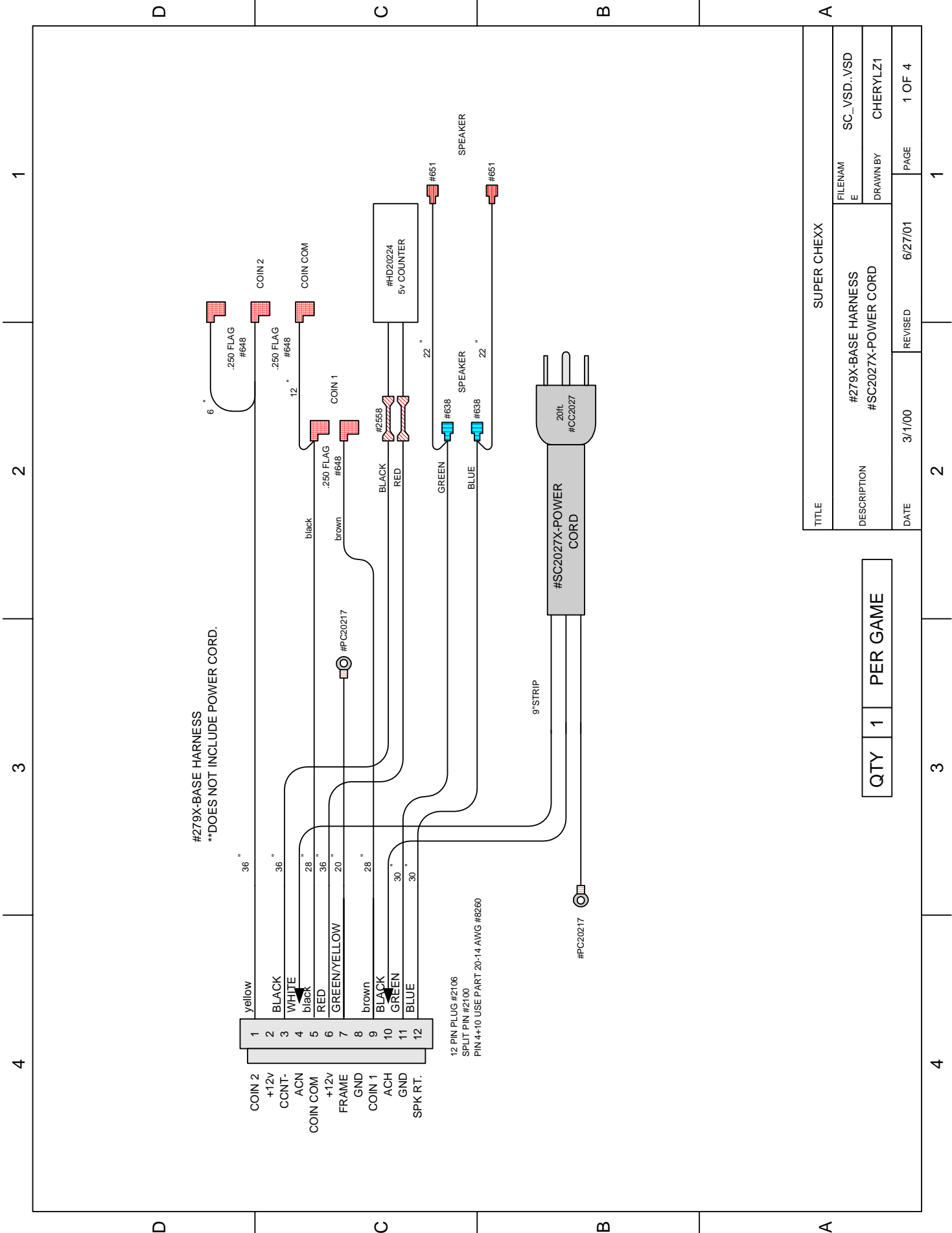

#279X-BASE HARNESS  
 \*\*DOES NOT INCLUDE POWER CORD.

- 1 yellow
- 2 BLACK
- 3 WHITE
- 4 black
- 5 RED
- 6 GREEN/YELLOW
- 7 brown
- 8 brown
- 9 BLACK
- 10 GREEN
- 11 BLUE
- 12

12 PIN PLUG #2106  
 SPLIT PIN #2100  
 PIN 4+10 USE PART 20-14 AWG #8260

TITLE		SUPER CHEXX	
DESCRIPTION	#279X-BASE HARNESS #SC2027X-POWER CORD	FILENAM E	SC_VSD..VSD
DATE	3/1/00	DRAWN BY	CHERYLZ1
		REVISED	6/27/01
		PAGE	1 OF 4

QTY	1	PER GAME
-----	---	----------

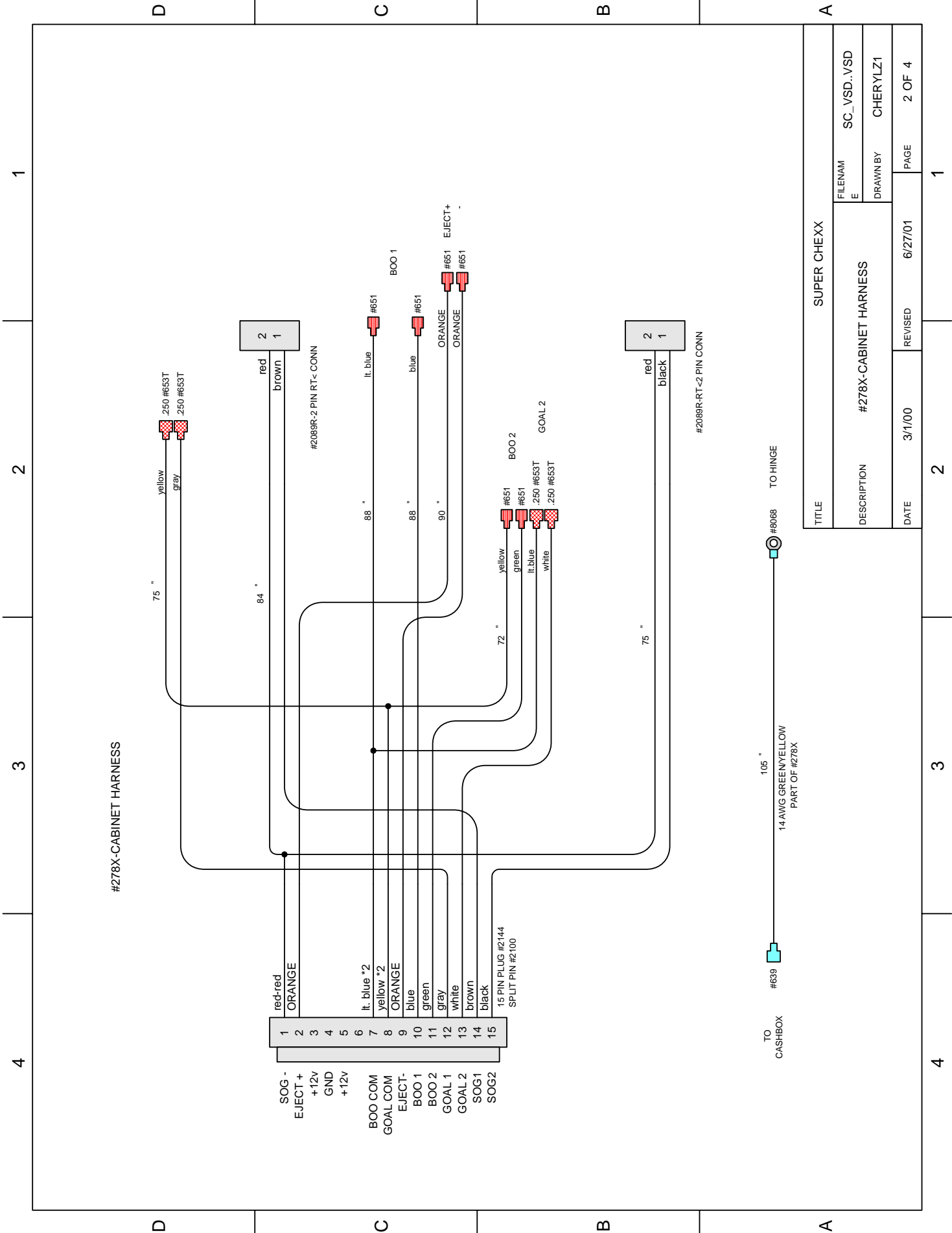

#278X-CABINET HARNESS

TITLE		SUPER CHEXX	
DESCRIPTION	#278X-CABINET HARNESS	FILENAM	SC_VSD..VSD
DATE	3/1/00	DRAWN BY	CHERYLZ1
REVISED	6/27/01	PAGE	2 OF 4



1 2 3 4

D

C

B

A

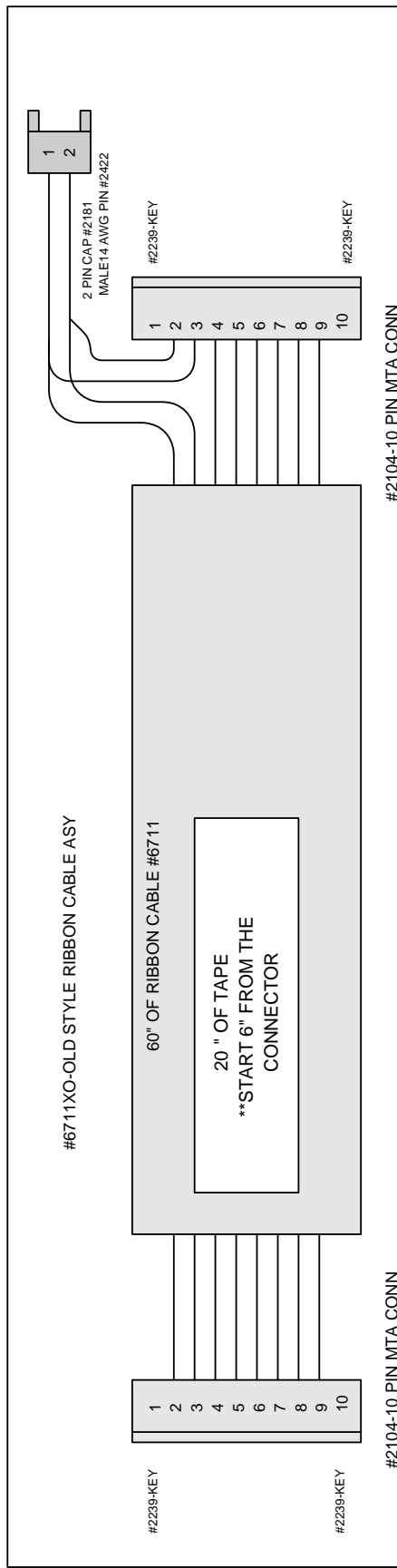
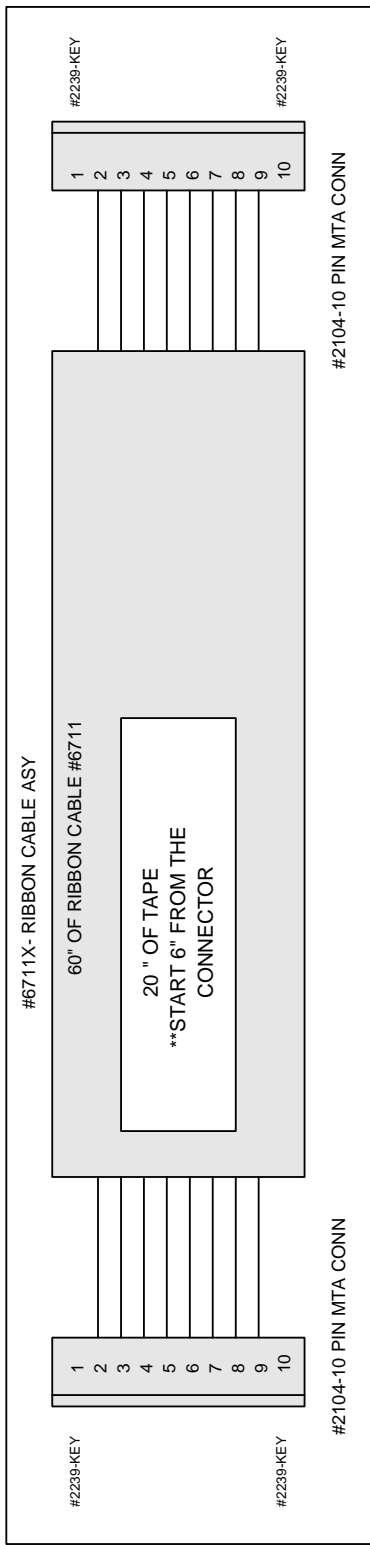

TITLE	SUPER CHEXX		
DESCRIPTION	FILENAM E	SC_VSD..VSD	
DATE	DRAWN BY	CHERYLZ1	
3/1/00	REVISED	6/27/01	PAGE 3 OF 4

1 2 3 4

D

C

B

A

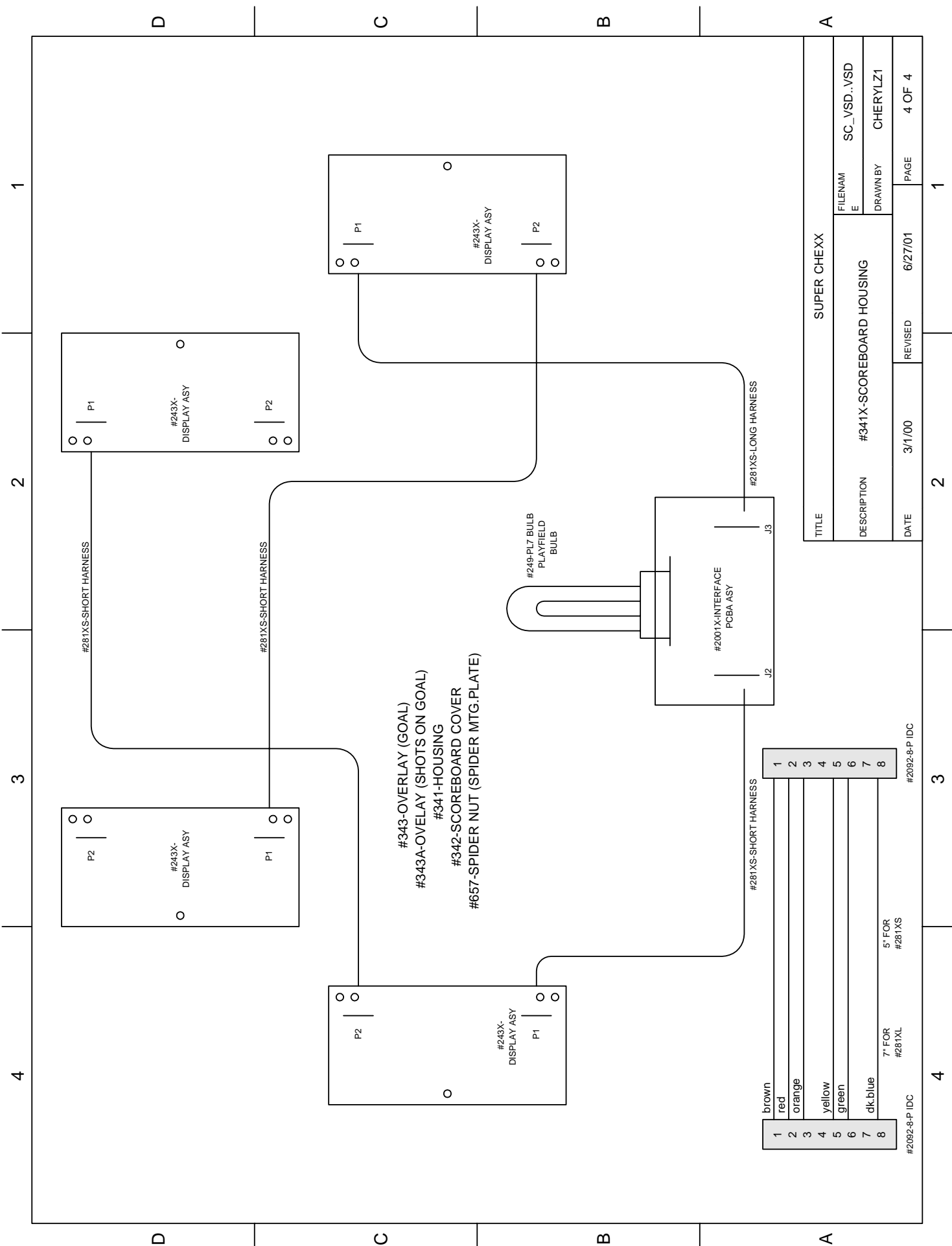

TITLE		SUPER CHEXX	
DESCRIPTION	#341X-Scoreboard Housing	FILENAM	SC_VSD..VSD
DATE	3/1/00	DRAWNBY	CHERYLZ1
REVISED	6/27/01	PAGE	4 OF 4

1	brown	1	7" FOR #281XL
2	red	2	5" FOR #281XS
3	orange	3	
4	yellow	4	
5	green	5	
6	dk.blue	6	
7		7	
8		8	

# Warranty

I.C.E warrants all components in the **SUPER CHEXX™** game to be free of defects in materials and workmanship for a period of ninety days from the date of purchase.

This warranty does not cover items damaged due to normal wear and tear, subjected to abuse, improperly assembled by the end user, modified, repaired, or operated in a fashion other than that described in the service manual.

If your **SUPER CHEXX™** game fails to conform to the above-mentioned warranty, I.C.E.'s sole responsibility shall be at its discretion to repair or replace any defective component with a new or remanufactured component of equal to or greater O.E.M. specification.

I.C.E. will assume no liability whatsoever, for costs associated with labor to replace defective parts, or travel time associated therein.

I.C.E.'s obligation will be to ship free of charge, replacement parts by U.P.S. Ground, U.S. mail, or other comparable shipping means. Any express mail or overnight shipping expense is at the cost of the purchaser.

Products will be covered under warranty only when:

- The serial number of the game with the defective parts is given.
- The serial number of the defective part, if applicable, is given.
- Defective parts are returned to I.C.E., shipping pre-paid, in a timely fashion, if requested by I.C.E.
- A copy of the sales receipt is available as proof of purchase upon request of I.C.E.

I.C.E. distributors are independent, privately owned and operated. In their judgment, they may sell parts or accessories other than those manufactured by I.C.E. We cannot be responsible for the quality, suitability, or safety of any non-I.C.E. part, or any modification, including labor, which is performed by such a distributor.



# WARRANTY

ICE Inc warrants that all of its products will be free from defects in material and workmanship.

When placing a warranty request, please be prepared to provide the following information:

- Serial Number of Game or Bill of Sale
- Machine Type
- A Detailed Description of the Equipment Fault Symptoms

ICE product, including Cromptons, Sam's Billiards, Uniana and Bell Fruit is warranted as follows:

- 180 days on the Main PCB and Computers
- 90 days on all other components (i.e. DBV's, Ticket Dispensers, etc)
- 30 days on repaired items
- 3 years on all Crane Harnessing
- 9 Months on Printers

DKS cashless systems offer a 3-year warranty on all components.

ICE Inc shall not be obligated to furnish a warranty request under the following conditions:

- Equipment has been subjected to unwarranted stress through abuse or neglect
- Equipment has been damaged as a result of arbitrary repair/modification attempts
- Equipment that has failed through normal wear and tear

ICE Inc will assume no liability whatsoever for costs associated with labor to replace defective parts or travel time associated therein.

All defective warranty covered components will be replaced with new or factory refurbished components equal to OEM specifications. ICE Inc will cover all UPS ground, or comparable shipping means, freight costs during the warranty period. Expedited shipments are available for an additional charge.

Defective parts are returned to ICE Inc, at the customer's expense, in a timely fashion.

ICE distributors are independent, privately owned and operated. In their judgment, they may sell parts and/or accessories other than those manufactured by ICE Inc. We cannot be responsible for the quality, suitability or safety of any non-ICE part, modification (including labor) that is performed by such a distributor.

I.C.E. Parts/Service Dept.  
Innovative Concepts in Entertainment  
10123 Main St.  
Clarence, NY 14031  
Phone #: (716) - 759 - 0360  
Fax #: (716) - 759 - 0884