

# PLUSH BUS™



## **OWNERS AND SERVICE MANUAL INNOVATIVE CONCEPTS IN ENTERTAINMENT INC.**



# TABLE OF CONTENTS

INTRODUCTION.....	PAGE 3
• GAME FEATURES	
• GAME PLAY	
SET-UP / TESTING / MAINTENANCE.....	PAGE 4 –11
• SAFETY PRECAUTIONS	
• GAME SET-UP	
• ASSEMBLY	
• TESTING	
• CLEANING	
• MANUAL SETTINGS	
• AUTO % SETTINGS	
• CLAW SHAPE	
PROGRAMMING.....	PAGE 12 –16
• OPTION MODES	
• ERROR CODES	
QUICK TROUBLESHOOTING.....	PAGE 17 –18
• PROBLEMS AND SOLUTIONS	
GAME REPAIR.....	PAGE 19 –21
• GLASS REPLACEMENT	
• MECHANICAL REPAIR	
• ELECTRICAL / ELECTRONIC REPAIR	
PARTS LISTINGS.....	PAGE 22
CRANE ASSEMBLY DIAGRAMS.....	PAGE 23 –26
SCHEMATICS / WIRING DIAGRAMS.....	PAGE 27 –45
WARRANTY INFORMATION.....	PAGE 46 –47

# INTRODUCTION

## GAME FEATURES

The brand new **PLUSH BUS™** all metal crane game by I.C.E. was designed with the operator in mind. Reliability, low maintenance, themed cabinetry, and all metal construction are the key design features, exactly what is needed to ensure a combination of long life and profit.

With nearly the entire construction made of metal, it was only natural to Powder Epoxy Coat everything, inside and out. This provides the owner – operator with a game that will certainly outlast its wooden counterparts. A few of the major advantages of all metal construction include:

- Vault like security
- Long service life
- Low maintenance
- High Durability

All windows, of the **PLUSH BUS™**, are ¼” tempered glass to provide an easy clean, maximum safety, scratch resistant surface. Other features include, 40 strand conductor cables to prevent wire fatigue, full range of operator adjustable software, and a newly designed crane mechanism.

The first step in I.C.E.’s new crane design was to select several leading cranes available on the market today, observe and determine what problems can be or are causes of failure and costly down time. I.C.E. then surveyed operators nation wide, requesting information like:

- What are the leading causes of crane failures in your locations
- What are some problems in servicing cranes
- What changes would you make to current cranes to create a better machine

I.C.E.’s engineers then compiled all critical data, addressed and corrected each problem and used this information to create what we call the **PLUSH BUS™**.

This method of design ensures that the needs and concerns of the owner-operators dictate the final design parameters, for who knows a crane’s attributes and faults better than a crane operator.

## GAME PLAY

As coins are inserted into the **PLUSH BUS™** all metal crane game, the sound of a “BUS” starting is heard. When sufficient coins have been inserted, the engine starts, the claw clicks closed and re-opens, which signals the start of the game. The crane will position itself in the middle of the “play field” and remain there, with the engine running, until the player is ready.

When the player has moved the joystick or pressed the buttons, to move the crane, the timer on the right display will begin to count down. The player will position the crane above the prize they are attempting to win and press the drop button to lower the claw.

If the nudging option is on, then the player will have the ability to keep “nudging” the claw down each time the button is pressed to home-in on the chosen prize. If the nudging option is off, then the player will have only one chance to drop the claw.

When the claw is fully dropped it will close and retract to its upper most position. The crane will then automatically position itself over the prize chute at the rear of the cabinet. The claw will open, releasing the prize into the prize chamber. The player can now remove the prize from the chamber through the prize door located in the front, lower left corner of the game. The game is now in its home position and is ready for the next player in line.

\*The crane will remain in the home position if game type (option 1) is set to 2 or 3. In this option the player has only two buttons, one for right travel and one for forward travel. The crane will remain in the home position to allow the player access to the entire play field.

# SETUP / TESTING / MAINTENANCE

## SAFETY PRECAUTIONS

IMPORTANT: FAILURE TO FOLLOW THESE DIRECTIONS CLOSELY COULD CAUSE SERIOUS DAMAGE TO YOUR GAME.

WARNING: WHEN INSTALLING THIS GAME, A 3-PRONG GROUNDED RECEPTACLE MUST BE USED. FAILURE TO DO SO COULD RESULT IN SERIOUS INJURY TO YOURSELF OR OTHERS. FAILURE TO USE A GROUNDED RECEPTACLE COULD ALSO CAUSE IMPROPER GAME OPERATION, OR DAMAGE TO THE ELECTRONICS.

DO NOT DEFEAT OR REMOVE THE GROUNDING PRONG ON THE POWER CORD FOR THE SAME REASONS AS GIVEN ABOVE. USING AN IMPROPERLY GROUNDED GAME COULD VOID YOUR WARRANTY.

## GAME SET-UP

BEFORE PLUGGING THE GAME IN, OR TURNING IT ON, BE SURE THE GAME HAS BEEN SET TO THE PROPER VOLTAGE. YOUR GAME SHOULD COME PRE-SET FROM THE FACTORY CORRECT VOLTAGE, HOWEVER IT IS A GOOD IDEA TO CHECK THE A.C. WALL RECEPTACLE VOLTAGE BEFORE PLUGGING THE GAME IN.

## ASSEMBLY INSTRUCTIONS

1. Carefully unbox the game from its packaging.
2. Using the supplied keys, unlock the front door of the cabinet.
3. Cut all tie wraps holding the wagon assembly and crane in place.
4. Plug the game into a three prong grounded receptacle. **NOTE:** The appliance must be positioned such that the plug is accessible during use.
5. The game is now ready for start up.

## TESTING

After the initial setup, it is time to test your game for proper operation.

1. Locate the game in its permanent location and lock all casters.
2. Be sure the game has been properly plugged into a 3-prong grounded outlet, and that the receptacle is in good working order.
3. If using an extension cord, be sure it is a 3-prong grounded type of at least 16Ga.
4. Verify that the game is set up for the proper voltage, and turn the power to the game on.
5. The game will run through a test mode at every startup. (See test mode explanation in the programming section for details.)
6. Insert coins/bills into the machine at least ten times into the coin mech/bill acceptor to ensure proper operation.
7. Check the credit and prize counters for proper operation.
8. Check that the door disconnect switch works properly.
9. Check game volume during busy time at location to set it at the proper level.

## CLEANING

Regular cleaning of this game will keep it looking new, and greatly enhance its appeal.

Clean the windows of your **PLUSH BUS™** with a standard window cleaner such as “Windex”®.

Clean the cabinet sides with a good cleaner such as “Fantastik”® or “409”® and a soft rag. A mild soapy solution can also be used.

**NOTE: DO NOT USE ALCOHOL, THINNERS OF ANY KIND, OR PINBALL PLAY FIELD CLEANERS ON ANY OF THE CABINET SURFACES ESPECIALLY THE DECALS.**

IF YOU HAVE ANY QUESTIONS OR COMMENTS REGARDING INSTALLATION OR PROPER FUNCTION OF YOUR GAME, PLEASE CALL OUR SERVICE DEPARTMENT AT (716)-759-0360

# SETUP / TESTING / MAINTENANCE

## MANUAL SETTING

### Initial adjustment tips

- It is important to know that a mechanical adjustment is known as a “Macro adjustment” or a large adjustment, and that a software adjustment is considered a “Micro adjustment” of a fine adjustment.
- **NOTE:** These adjustments need only be performed when setting up the crane for the first time or when major changes to plush size and or shape occur. Once a configuration has been determined for your particular requirements, the same configuration in another CRANE GAME may require only minor adjustments.
- Pack in the same fashion as usual and stay consistent
- Set option 0 (Game mode) for game type you desire.
- Set option 3 (Game cost) for your particular game.
- For the following tests make sure that option 9 (Auto Strength) is set to 00. Any setting other than 00 and auto percentaging is enabled and incorrect results may occur.
- Make sure that the claw tips, when closed, are just touching. DO NOT allow them to overlap, for the claw could mechanically bind causing some down time.
- **CHECK IF YOU HAVE THE CORRECT CLAW SHAPE.** Set option 8 to 50, 9 to 00, and play the game approx. 25 times. At this level you should have great difficulty picking up plush.
  - If you are able to pick up the plush rather easily, you have the wrong claw shape or size and you should go to the end of this section and see **CLAW SHAPE**.
  - If you are unable to pick up the plush then set option 8 to 99 and play 25 games. You should now be able to pick up the plush fairly consistently. If this is true, continue on to the next step. **NOTE:** When the game is first packed it is often difficult to pick up plush until an area is cleared to maneuver in. Take this into account while determining if the claw size or shape is correct.
  - Initially set option 8 (Manual strength), based on your size plush, such that the claw is barely able to hold the plush when closed. If you are unsure, a good starting point for option 8 is 60 for average size plush and our standard medium claw. **NOTE:** When in programming mode at option 8 the claw will begin to open and close at approximately 5 second intervals. The operator can then associate the claw strength number on the right display with actual “physical” claw strength at the claw.
  - Knowing the cost of a game, the average cost of a piece of plush, and the desired pay out % calculate the proper plush dispensing intervals, for your setup, using the following formula:
    - 1.)  $100 * (\text{Game cost}) = A$  (# of dollars received for 100 games)
    - 2.)  $A * (\text{Desired payout \%}) = B$  (# of dollars worth of plush that should be dispensed in 100 games)
    - 3.)  $B / (\text{Desired payout \%}) = C$  (# of pieces of plush that should be dispensed in 100 games)
    - 4.)  $100 C =$  Proper plush dispensing intervals

# SETUP / TESTING / MAINTENANCE

## EXAMPLE

Game Cost	= \$0.50
Avg. cost of 1 plush	= \$2.00
Desired payout %	= 33%

- 1.) 100 \* (\$0.50) = \$50
- 2.) \$50 \* (.33) = \$16.50 worth of plush in 100 games to give a 33% payout
- 3.) \$16.5 / (\$2.00) = 8.25 pieces of plush per 100 games to give a 33% payout
- 4.) 100 / (8.25) = 12.12 round off to 12

**NOTE:** This means that approximately every 12<sup>th</sup> game played 1 piece of plush should be won.

Armed with the information particular to your game (Proper plush dispensing intervals determined above) play at least 50 games and see if the correct number of plush have been dispensed. (For the example above, in 50 games you should have dispensed approximately 4 pieces of plush (Every 12.12 games.)

**NOTE:** The more games you play during the "TEST" the more accurate your accounting will be. When 50 games have been played calculate the payout % using the formula below:

$$1.) \frac{(\# \text{ of plush dispensed}) * (\text{Cost of 1 pc. of plush})}{(\# \text{ of games played}) * (\text{Cost of game})} = \text{Payout \%}$$

## EXAMPLE

Cost of a game	= \$0.50
Cost of 1 piece of plush	= \$2.00
# of plush dispensed	= 55
# of games played	= 423
$\frac{(55) * (\$2.00)}{(423) * (\$0.50)}$	= 52 = 52% payout

If the calculated pay out is very high, (your desired pay out + 10% or more), it will be necessary to make a macro adjustment or move the claw tips apart slightly by loosening the three screws holding the coil slider to the coil housing and moving the coil slider up slightly. (See Fig. 1) **NOTE:** MOVING THE COIL SLIDER 1/8<sup>TH</sup> OF AN INCH COULD CHANGE YOUR PAY OUT BY AS MUCH AS 60%. BE SURE TO MOVE THE SLIDER IN VERY SMALL INCREMENTS SO AS NOT TO OVERSHOOT YOUR DESIRED PAYOUT.

If the calculated payout is slightly high, (your desired payout + less than 10% or more), then you can make a micro adjustment or a software claw strength adjustment at option 8.

Conversely, if the calculated payout is very low or slightly low you will need to make a macro or micro adjustment accordingly.

Repeat the 50 game test and calculate the payout %. Repeat the mechanical adjustment until you are within approximately 5-10% of your desired payout. You can now enter the programming mode and adjust option 8 (Mechanical strength) up or down slightly to achieve your desired payout. Your game is now set up according to your Desired Payout, Game cost, and Plush cost. If, at a later date, you want to change your game cost, desired payout, plush cost, etc., it is **NOT** necessary to re-adjust your game manually. Just adjust the value of the option you wish to change in the PROGRAMMING SECTION. The game will adjust to your new configuration.

If after using the Initial adjustment tips above, you are still having difficulty in setting up your Crane Game, please call the I.C.E. service line @ 1-(716)-759-0360.

# SETUP / TESTING / MAINTENANCE

## AUTO % SETTINGS

Initial adjustment tips

- Before setting up auto percentaging it is highly advisable to set up manual percentaging. This is a precaution in the unlikely event that the prize sensor fails or error code 10 or 11 is logged. If either one of these situations occurs the game will AUTOMATICALLY revert to manual percentaging settings, allowing the game to still function until the error is corrected. If your manual settings are not set up, it may be possible to dispense too much plush resulting in a loss of revenue for that week, or dispensing too little plush causing your customers to feel as though they cannot win which will eventually result in a loss of play and revenue.

- It is important to know that a mechanical adjustment is known as a “Macro adjustment” or a large adjustment, and that a software adjustment is considered a “Micro adjustment” or a fine adjustment.

- **NOTE:** These adjustments need only be performed when setting up the crane for the first time or when major changes to plush size and or shape occur. Once a configuration has been determined for your particular requirements, the same configuration in another CRANE GAME may require only minor adjustments.

- Pack in the same fashion as usual and stay consistent.

- Set option 0 (Game mode) for game type you desire.

- Set option 3 (Game cost) for your particular game.

- Make sure that the claw tips, when closed, are just touching. DO NOT allow them to overlap, for the claw could mechanically bind causing some down time.

- **CHECK IF YOU HAVE THE CORRECT CLAW SHAPE.** Set option 8 to 50, 9 to 00 and play the game approx. 25 times. At this level you should have great difficulty picking up plush.

- If you are able to pick up the plush rather easy, you have the wrong claw shape or size and you should go to the end of this section and see **CLAW SHAPE**.

- If you are unable to pick up the plush then set option 8 to 99 and play 25 games. You should now be able to pick up the plush fairly consistently. If this is true, continue on to the next step.

**NOTE:** When the game is first packed it is often difficult to pick up plush until an area is cleared to maneuver in. Take this into account while determining if the claw size or shape is correct.

- Make sure option 8 (Manual Strength) is set up as detailed above before setting up auto %

- Make sure option 9 (Auto Strength) is set to 60. **NOTE:** This is a good setting for jumbo mix and a medium claw. It is advisable to keep the claw strength high enough to slightly move the plush around yet low enough to prevent a player from easily picking up a prize.

- Set option 16 (Plush Cost) based on the cost of your plush.

- Set option 17 (Desired Payout %) based on your desired payout.

- Knowing the cost of a game, the average cost of a piece of plush and the desired pay out %, calculate the proper plush dispensing intervals for your setup, using the following formula:

1.)  $100 * (\text{Game cost}) = A$  (# of dollars received for 100 games)

2.)  $A * (\text{Desired payout \%}) = B$  (# of dollars worth of plush that should be dispensed in 100 games)

3.)  $B / (\text{Desired payout \%}) = C$  (# of pieces of plush that should be dispensed in 100 games)

4.)  $100 C =$  Proper plush dispensing intervals

# SETUP / TESTING / MAINTENANCE

## EXAMPLE

Game Cost	= \$0.50
Avg. cost of 1 plush	= \$2.00
Desired payout %	= 33%

- 1.) 100 \* (\$0.50) = \$50
- 2.) \$50 \* (.33) = \$16.50 worth of plush in 100 games to give a 33% payout
- 3.) \$16.5 / (\$2.00) = 8.25 pieces of plush per 100 games to give a 33% payout
- 4.) 100 / (8.25) = 12.12 round off to 12

**NOTE:** This means that approximately every 12<sup>th</sup> game played 1 piece of plush should be won.

Armed with the information particular to your game (Proper plush dispensing intervals determined above) play at least 50 games and see if the correct number of plush have been dispensed. (For the example above, in 50 games you should have dispensed approximately 4 pieces of plush (Every 12.12 games.)

**NOTE:** The more games you play during the "TEST" the more accurate your accounting will be). When 50 games have been played calculate the payout % using the formula below:

$$1.) \frac{(\# \text{ of plush dispensed}) * (\text{Cost of 1 pc. of plush})}{(\# \text{ of games played}) * (\text{Cost of game})} = \text{Payout \%}$$

## EXAMPLE

Cost of a game	= \$0.50
Cost of 1 piece of plush	= \$2.00
# of plush dispensed	= 55
# of games played	= 423
$\frac{(55) * (\$2.00)}{(423) * (\$0.50)}$	= 52 = 52% payout

If the calculated pay out is very high, (your desired pay out + 10% or more), it will be necessary to make a macro adjustment or move the claw tips apart slightly by loosening the three screws holding the coil slider to the coil housing and moving the coil slider up slightly. (See Fig. 1) **NOTE:** MOVING THE COIL SLIDER 1/8<sup>TH</sup> OF AN INCH COULD CHANGE YOUR PAY OUT BY AS MUCH AS 60%. BE SURE TO MOVE THE SLIDER IN VERY SMALL INCREMENTS SO AS NOT TO OVERSHOOT YOUR DESIRED PAYOUT.

If the calculated payout is slightly high, (your desired payout + less than 10% or more), then you can make a micro adjustment or a software claw strength adjustment at option 8.

Conversely, if the calculated payout is very low or slightly low you will need to make a macro or micro adjustment accordingly.

Repeat the 50 game test and calculate the payout %. Repeat the mechanical adjustment until you are within approximately 5-10% of your desired payout. You can now enter the programming mode and adjust option 8 (Mechanical strength) up or down slightly to achieve your desired payout. Your game is now set up according to your Desired payout, Game cost, and Plush cost. If, at a later date, you want to change your game cost, desired payout, plush cost, etc., it is **NOT** necessary to re-adjust your game manually. Just adjust the value of the option you wish to change in the PROGRAMMING SECTION. The game will adjust to your new configuration.

If after using the Initial adjustment tips above, you are still having difficulty in setting up your Crane Game, please call the I.C.E. service line @ 1-(716)-759-0360.



# SETUP / TESTING / MAINTENANCE

## CLAW SHAPE

In an attempt to satisfy all variables associated with the proper payout ICE has opted to include directions on how to reshape your medium claw for a lesser and greater mechanical advantage. Below are two medium claws shapes which will give very different mechanical advantages and ultimately very different claw strengths.

- When option 8 is set to 50 and you are still picking up plush, then you will need to reshape your 3 claws to look more like shape "A". (SEE FIG. 2) **NOTE:** Be sure to align holes in the claw with drawn holes in the template. This will ensure proper shaping of the claw.
- When option 8 is set to 99 and you are unable to pick up consistently then you will need to reshape your 3 claws to look more like shape "B". (SEE FIG. 2) **NOTE:** Be sure to align holes in the claw with drawn holes in the template. This will ensure proper shaping of the claw.

These are the two claw shapes that ICE has proven work well, although there are many other shapes that may work. You will need to remove the claws from the claw mechanism by following the steps.

1. Remove the claw mechanism from the coil housing by loosening the three screws on the coil slider and removing. Be sure not to loose the small spring around the plunger and the black rynite washer below the spring. These two parts are critical in the proper operation of the crane mechanism. (SEE FIG.1)
2. Loosen and remove the 6 small Philips head machine screws and nylock nuts attaching the three claws to the coil-claw interconnect and coil spider (SEE FIG. 1)
3. Reshape the claws according to the claw shape templates "A" or "B".
4. Re assemble in reverse order.

Now that you have reshaped your claws for your plush, return to the beginning of Adjustment tips and proceed through each step.

FIG. 1

# Claw Assembly

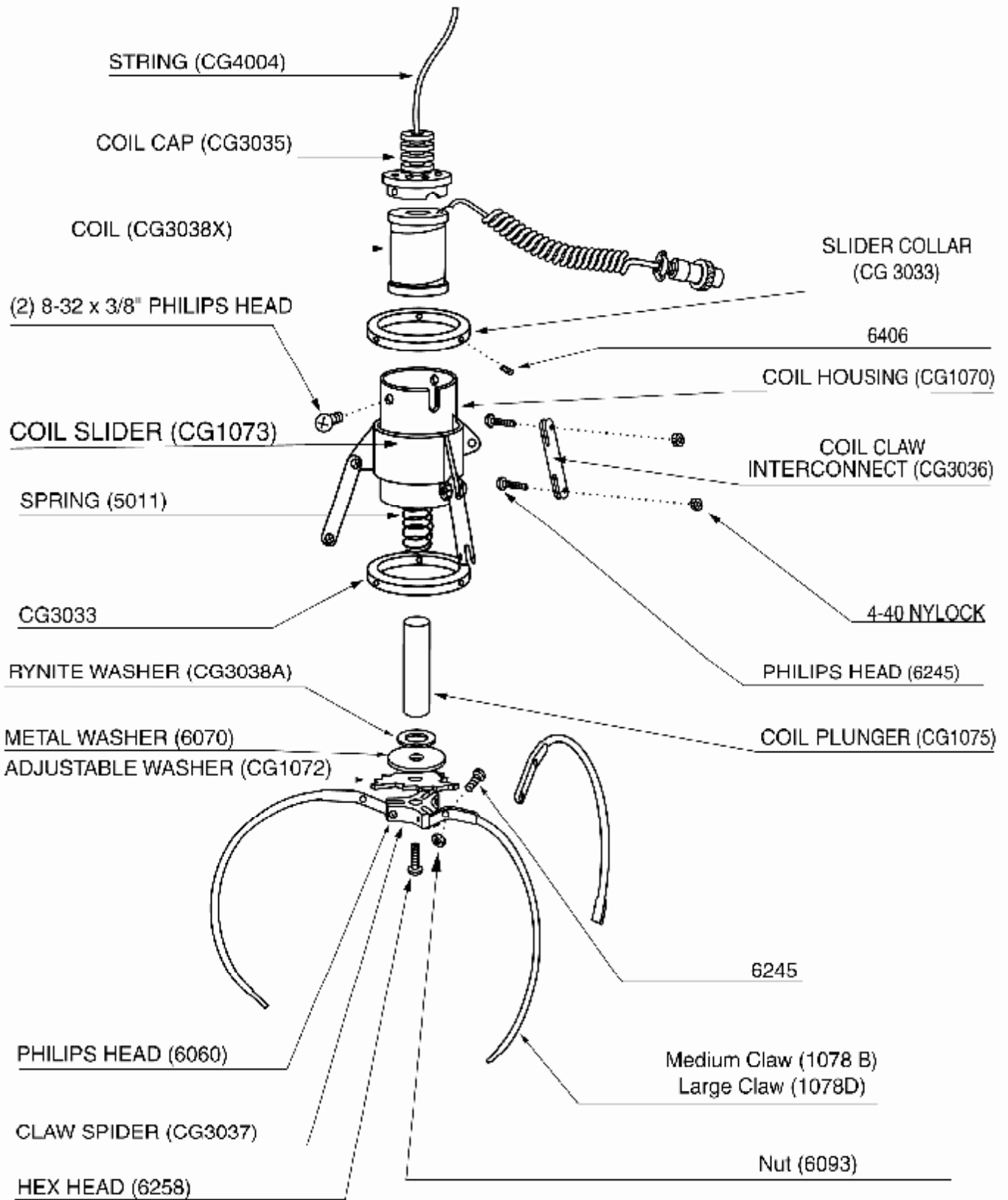

# CLAW TEMPLATES

FIG. 2

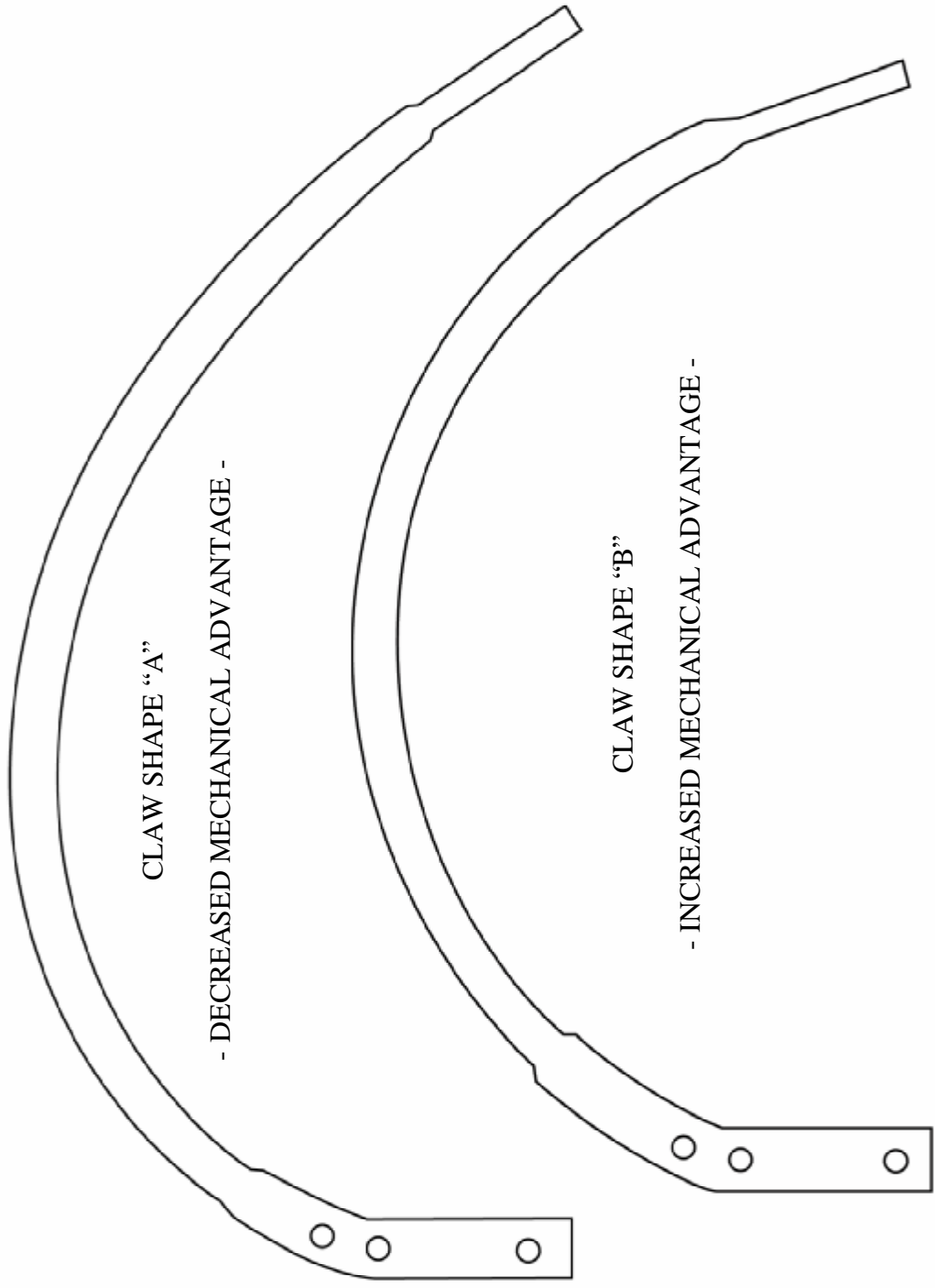

NOTE: THESE ARE THE TWO CLAW SHAPES THAT HAVE BEEN THOROUGHLY TESTED BY I.C.E. AND ARE PROVEN TO WORK. THEY SHOULD BE USED AS A GUIDE TO INCREASE OR DECREASE THE MECHANICAL ADVANTAGE OF THE CLAW FOR YOUR PARTICULAR PUSHER. OTHER CLAW SHAPES BETWEEN CLAW SHAPES A & B MAY WORK BUT WILL REQUIRE FURTHER TESTING.

# PROGRAMMING

<u>Mode</u> (Credit Display)	<u>Description</u>	<u>Min/Max/Def</u> (Timer Display)	<u>Meaning</u>
<b>BASIC PROGRAMMING</b>			
0	Game Type	0,4,0	0 - Left, Right, Forward, Backward, Nudge 1 - Left, Right, Forward, Backward, Drop 2 - Right, Forward, Nudge 3 - Right, Forward, Drop 4 - Single Move, Drop
1	Game Mode	0,1,0	0 - Normal Play 1 - Play till you win
2	Time	10,60,20	10 - 60 Seconds (Inc. every 5 seconds)
3	Coin	0,9,2	0 - Free Play 1-9 Coins required for a single credit
4	Bill	0,9,4	0 - Off 1-9 Number of coins each bill is worth
5	Counter Type	0,1,0	0 - Credit counter 1 - Coin counter
6	Attract	1,30,20	1 - 30 Minutes between attract modes
7	Attract Type	1,2,2	1 - Motion only 2 - Audio and motion
8	Manual Strength	40,99,75	40-99 Claw strength Inc. by 1 (99 = MAX)
<b>ADVANCED PROGRAMMING</b>			
9	Auto Strength	0,99,0	0 - Auto off 40 - 99 Claw strength in auto (99 = MAX)
10	F/B Speed	10,20,20	10 = Low speed 20 = High speed
11	L/R Speed	10,20,20	10 = Low speed 20 = High speed
12	UP Speed	15,20,17	15 = Low speed 20 = High speed
13	Down Speed	15,20,20	15 = Low speed 20 = High speed
14	Right Time	0,40,8	0 - 40 Number of ¼ sec time intervals right
15	Forward Time	0,40,5	0 - 40 Number of ¼ sec time intervals forward
16	Plush Cost	1,20,4	Coins per piece of plush
17	Payout	20,50,33	20 - 50 Desired payout percentage
18	Tickets to play	0,99,0	0 - 99 tickets to be paid just to play game
19	Tickets if loose	0,99,0	0 - 99 tickets to be paid if you do not win plush
20	Factory Default	0,1,0	0 - Normal 1 - Restore factory defaults upon next startup
21	Center On/Off	0,1,0	0 - Center option is off 1 - Center option is on
22	Snap On/Off	0,1,1	0 - Snap option is off 1 - Snap option is on
23	Games per Credit	1,9,1	1 - 9 Games per credit
24	Coin Discount	0,9,0	0 - 9 Number of consecutive coins for free game
25	Up/ Down Motor Test	DIAG.	Right display changes: 0-1 Up switch is made 0-2 Down switch is made 0-3 Both switches are made
26	Left/Right Motor Test	DIAG.	Right display changes: 0-1 Left switch is made
27	Front/Back Motor Test	DIAG.	Right display changes: 0-1 Back switch is made

# PROGRAMMING

## Mode Explanations

0. GAME TYPE – There are 5 game types:

- 0 Left, Right, Forward, Backward, Nudge – This mode is for a control panel that commonly has a joystick and allows the player to lower the claw each time the drop button is pressed. This allows the player to home-in on the prize they are attempting to win. **NOTE:** The crane will position itself according to the operator presets, options 14 and 15, at coin up, if option 21 is set to “0” (off). The crane will position itself according to the operator presets, options 14 and 15, at the end of the game, if option 21 is set to “1” (on).

- 1 Left, Right, Forward, Backward, Drop - This mode is for a control panel that commonly has a joystick and the claw drops fully when the button is pressed. **NOTE:** The crane will position itself according to the operator presets, options 14 and 15, at coin up, if option 21 is set to “0” (off). The crane will position itself according to the operator presets, options 14 and 15, at the end of the game, if option 21 is set to “1” (on).

- 2 Right, Forward, Nudge – This mode is for a control panel that commonly has 3 buttons, one to move right, one to move forward and one to drop the claw. The player also has the ability to drop the claw each time the button is pressed. This allows the player to home-in on the prize they are attempting to win. **NOTE:** Option 21 is not available with this mode and will remain at “0” (off).

- 3 Right, Forward, Drop – This mode is for a control panel that commonly has 3 buttons, one to move right, one to move forward and one to drop the claw. The claw drops fully when the button is pressed. **NOTE:** Option 21 is not available with this mode and will remain at “0” (off).

- 4 Single Move Drop – This mode is for a control panel with two buttons only, one to move forward and one to move to the right. At coin up, claw will remain over the prize chute to give the player full access to the playfield. The player will have a chance to move the crane once forward and once to the right, after which the claw will automatically drop.

1. GAME MODE – There are two game modes:

- Normal play – This is the standard type of play where a player has inserted enough coins to create 1 credit and then plays the game. Whether the player wins a prize or not, the game is over.
- Play till win – In this mode the player has inserted enough coins to create 1 credit and will be able to play the game until they win a prize.

2. TIME – This option allows the operator to set the game play length. Options are from 10 seconds to 60 seconds in 5 second intervals.

3. COIN – This option allows the operator to set the number of coins needed to create 1 credit. A setting of “0” will put the game into free play.

4. BILL – This option allows the operator to set the number of coins each bill is worth. A setting of “0” turns this option off.

5. COUNTER TYPE – Setting this option to “0” will have the game count credits on the mechanical and software counters. Setting this option to “1” will have the game count coins.

6. ATTRACT – This option allows the operator to set the number of minutes between attract modes. Available settings are from 1 minute to 30 minutes in 1 minute intervals.

7. ATTRACT TYPE – This option allows the operator to choose what type of attract mode they want.

- “1” will have an attract mode with movement only.
- “2” will have an attract mode with both audio and movement.

# PROGRAMMING

8. MANUAL STRENGTH – This option allows the operator to set the strength of the claw for manual percentaging. Available claw strengths are 40-99 with 99 = 100% claw strength. **NOTE:** When in this mode the claw will open and close with the strength set in this mode. The operator will be able to feel each strength setting to determine which best suits their needs. When the correct strength setting is determined the operator can just move to the next option, and the manual strength option is set.
9. AUTO STRENGTH – This option allows the operator to set the claw strength for the auto percentaging mode. Available claw strengths are 40-99 with 99 = 100% claw strength. **NOTE:** When in auto percentaging mode the claw will, at bottoming, close with 100% strength and will then be backed off to the number set in this mode. i.e. With this mode set to 75, the claw will at bottoming close with 100% strength then back off to 75. **NOTE:** The claw will open and close allowing the operator to feel each strength setting to determine which best suits their needs. When the correct setting is determined the operator can just move to the next option, and the auto strength option is set.
10. F/B SPEED – This option allows the operator to adjust the forward / backward speed of the crane. The available speeds are 10-20 with 10 being slow and 20 being fast.
11. L/R SPEED – This option allows the operator to adjust the left right speed of the wagon. The available speeds are 10-20 with 10 being slow and 20 being fast.
12. UP SPEED – This option allows the operator to adjust the speed of the crane. The available speeds are 15-20 with 15 being slow and 20 being fast.
13. DOWN SPEED – This option allows the operator to adjust the down speed of the crane. The available speeds are 15-20 with 15 being slow and 20 being fast.
14. RIGHT TIME – This option allows the operator to adjust the time the right motor drive will stay on, for centering purposes at game start up. Available settings are 0-40 intervals of  $\frac{1}{4}$  sec. **EXAMPLE:** If this option is set at five, then the right drive motor will stay on for  $(5 \times \frac{1}{4} \text{ sec} = 1\frac{1}{4} \text{ sec.})$   $1\frac{1}{4}$  sec. This option is used to correctly center the crane at coin up with different coin speeds and crane sizes. The operator can also use this option along with option 21 to adjust the position of the crane head when the game is over.
15. FORWARD TIME – This option allows the operator to adjust the time the forward motor drive will stay on, for centering purposes at game start up. Available settings are 0-40 intervals of  $\frac{1}{4}$  sec. **EXAMPLE:** If this option is set at five, then the forward drive motor will stay on for  $(5 \times \frac{1}{4} \text{ sec} = 1\frac{1}{4} \text{ sec.})$   $1\frac{1}{4}$  sec. This option is used to correctly center the crane at coin up with different coin speeds and crane sizes. The operator can also use this option along with option 21 to adjust the position of the crane head when the game is over.
16. PLUSH COST – The operator will use this option to detail the cost of an average piece of plush used in their crane, in terms of the lowest denominator coin used to coin up the game. **EXAMPLE:** If the average cost of a piece of plush is \$1.50 and the lowest denominator coin used to coin up the game is \$0.25 then the number entered for this option will be 6 ( $\$1.50 / \$0.25 = 6$ ). The available plush costs for this option are 1-20.
17. DESIRED PAYOUT – The operator will input the desired payout for the auto percentaging mode. The available percentages for this option are 20% - 50%.
18. TICKETS TO PLAY – This option is used only if you have a ticket dispenser. In this option the operator has the ability to set the number of tickets that a player will be awarded just for playing the game. The available range is 0-99 tickets.
19. TICKETS IF LOSE – This option is used only if you have a ticket dispenser. In this option the operator has the ability to set the number of tickets that a player will be awarded when a piece of plush is not won. The available range is 0-99 tickets.

# PROGRAMMING

20. FACTORY DEFAULTS – A setting of “0” for this option will keep the latest operator settings. A setting of “1” for this option will restore all options to factory defaults.
21. CENTERING – This option allows the operator to position the crane any where on the play field. If option 21 is set to “0” (Off), the crane head will position itself at the beginning of the game according to the operator pre-sets in options 14 and 15. If option 21 is set to “1” (On), the crane head will position itself at the end of the game according to the operator pre-sets in options 14 and 15.
22. SNAP – This option allows the operator to turn off and on the snap of the claws at the start of the game. If option 22 is set to “0” (Off), the claws will not snap together at the start of a game. If option 22 is set to “1” (On), the claws will snap together at the start of a game.
23. GAMES PER CREDIT – This option determines how many games or turns the player gets per credit. This option is useful if you have a minimum coin value that is so high you need to give the customer multiple games to get good value. The range for this option is 1-9. The default value for this option is “1”.
24. COIN DISCOUNT – This determines the number of consecutive credits (without playing a game) given before dispensing a free game. For example: If this option was set to “2”, each time 2 coins IN A ROW were put in, a free game would be given. The range for this option is 0-9. The default value for this option is “0”.
25. UP/DOWN MOTOR TEST – When the operator moves the joystick left and right the claw will raise and lower respectively. The display will change from:
  - 0-1 if the up switch is made
  - 0-2 if the down switch is made
  - 0-3 if both switches are made
26. LEFT/RIGHT MOTOR TEST – When the joystick is moved left and right the wagon assembly will move to the left and right. The right display will change from:
  - 0-1 if the left home switch is made
27. FRONT/BACK MOTOR TEST – When the joystick is moved left and right the wagon assembly will move forward and backward. The right display will change from:
  - 0-1 if the back home switch is made

## Entering the Programming Mode

To enter the programming mode, open the front door and press the button marked PROG, located on the main board housing inside the front door, and the crane will move to the front center of the game. **NOTE:** The game WILL NOT go into the programming mode if the door is “closed”, or the door switch has been pulled to the outer most position. Once you are in the programming mode move the joystick forward and backward or use the forward button to move through the modes. To change the value of the mode move the joystick left and right or use the right button. Once all options have been set, press the drop button and the game will return to regular game play with the new settings. For a 2 button control panel, press the third button located inside the front door.

## Entering the Accounting Mode

To enter the accounting mode, open the front door and press the button marked ACCOUNT, located on the main board housing inside the front door. The left displays will flash between “cr” (credits) then the number of credits 1-9999. If the operator presses the drop button the displays will flash “pl” (plush), then the number of plush that have passed through the sensor. These numbers can never be reset and WILL NOT match the numbers on the mechanical counters from the counters. It is advisable that the owner note this difference so that they will be able to track actual software coins/credits and plush out vs. mechanical counters for accounting purposes.

# PROGRAMMING

## Test Mode Explanation

Every time that the game is powered up, or the door is closed, the game will run through a test mode to check the following items:

- |                   |                         |                          |
|-------------------|-------------------------|--------------------------|
| -HOME BACK SWITCH | -FRONT/BACK MOTOR       | -PRIZE SENSOR            |
| -HOME LEFT SWITCH | -LEFT/RIGHT MOTOR       | -OUT OF RANGE            |
| -UP SWITCH        | -CREDIT/COIN DISCONNECT | -E <sup>2</sup> (MEMORY) |
| -DOWN SWITCH      | -CLAW CLOSE, CLAW OPEN  |                          |

If any of the above items are malfunctioning, the game will light the 4 decimal points on the podium displays. This will alert the operator that there has been a problem. The operator needs only unlock and open the front door and the error codes will be displayed one at a time on the left display. To move to the next error code the operator needs to press the drop button. Repairs should be made to those areas in which errors have been logged. When all codes have been seen and the door is closed the game will reset error codes, run through a test mode to check for proper operation and, if all is well, game play can start. If the 4 decimals once again light up, the operator will need to check the error codes again. The play can continue to the best of the machine's abilities, with problems, until the errors are corrected. At no time should the game be inoperable unless a key component is damaged.

Error code 10/11 will alert the operator that the game has paid out 8 too many or 8 too few pieces of plush than in auto percentaging. If this error is logged the game will automatically revert to MANUAL settings until one of the following options is changed: (COST OF PLUSH, AUTO % MIN., % PAYOUT, OR GAME COST.) This is why it is imperative that the manual settings be setup before auto percentaging is used.

**NOTE:** Changing one of these options will reset error code 10/11 and the game will begin auto percentaging with the new settings.

**NOTE:** Some items on the list cannot be detected by the game and require that the operator watches for these actions to be performed during the start up test mode. (Claw close, Claw open.)

## Error Codes

<u>#</u>	<u>Problem</u>	<u>Solution</u>
1	E <sup>2</sup> (Memory)	Replace Microprocessor @U7
2	Prize Sensor	Check/Replace Prize Sensor
3	Up Sensor	Check/Replace Up Sensor
4	Down Sensor	Check/Replace Down Sensor
5	Left/Right Sensor	Check/Replace L/R Sensor
6	Front/Back Sensor	Check/Replace F/B Sensor
7	Left/Right Motor	Check/Replace L/R Motor
8	Front/Back Motor	Check/Replace F/B Motor
9	Counter Disconnect	Just a warning that the credit/coin counters were disconnected at some time.
10	Out Of Range (High)	Change setting for the Cost of Plush, Auto % min, % Payout, or Game Cost
11	Out Of Range (Low)	Change setting for the Cost of Plush, Auto % min, % Payout, or Game Cost



# QUICK TROUBLESHOOTING

PROBLEM	PROBABLE CAUSE	SOLUTION
THE DECIMALS ON THE 4 DISPLAYS ARE LIT UP	THIS IS IN FACT NOT A PROBLEM BUT A WAY OF LETTING THE OPERATOR KNOW THAT THERE WAS A PROBLEM DURING THE START UP MODE	OPEN THE FRONT DOOR AND THE ERROR CODES ARE SHOWN ON THE DISPLAYS. TO ADVANCE THROUGH THE ERROR CODES, PRESS THE DROP BUTTON
NO GAME POWER	ON-OFF SWITCH ON THE GAME IS TURNED OFF BLOWN A.C. POWER FUSE GAME NOT PLUGGED IN OR CORD DAMAGED BAD TRANSFORMER TRANSFORMER HARNESS NOT CONNECTED BAD POWER MODULE	TURN POWER ON REPLACE WITH PROPER FUSE CHECK POWER CORD CHECK PROPER VOLTAGES CHECK HARNESS REPLACE POWER MODULE
GAME WILL NOT TAKE MONEY OR GIVE CREDITS CORRECTLY	BAD COIN SWITCH COIN DISCOUNTING OPTION IS SET WRONG COINS PER CREDIT SETTING INCORRECT BAD COIN MECHANISM LOOSE OR DAMAGED HARNESSING BAD MAIN P.C. BOARD	CHECK W / METER AND REPLACE CHECK PROGRAMMABLE SETTING CHECK PROGRAMMABLE SETTING ADJUST OR REPLACE CHECK W / METER AND REPAIR REPAIR OR REPLACE MAIN BOARD
HEADLIGHT / BLINKING LIGHTS DO NOT LIGHT	BAD BULB BAD DRIVE TRANSISTOR ON P.C. BOARD BLOWN 12V FUSE ON MAIN P.C. BOARD	REPLACE BULB REPLACE TRANSISTOR REPLACE WITH PROPER FUSE
DISPLAYS DO NOT WORK	BAD 12V FUSE BAD DISPLAY P.C. BOARD BAD MAIN P.C. BOARD LOOSE OR DAMAGED DISPLAY HARNESSING	REPLACE WITH PROPER FUSE REPAIR OR REPLACE P.C. BOARD REPAIR OR REPLACE P.C. BOARD CHECK W / METER AND REPAIR
CRANE OR WAGON DOES NOT MOVE	BAD MOTOR LOOSE OR DAMAGED HARNESSING BAD SWITCH ON BUTTON OR JOYSTICK BAD HARNESSING TO BUTTONS OR JOYSTICK BLOWN FUSE TO MOTORS ON MAIN P.C. BOARD	REPLACE MOTOR CHECK W / METER AND REPAIR REPLACE SWITCH CHECK W / METER AND REPAIR REPLACE WITH PROPER FUSE
CRANE KEEPS TRYING TO MOVE IN THE HOME POSITION	BAD LIMIT SWITCH (S) LIMIT SWITCH NOT ALIGNED WITH ACTUATOR	REPLACE SWITCH (S) ALIGN SWITCH AND ACTUATOR
CLAW WILL NOT CLOSE	BLOWN FUSE TO CLAW ON MAIN P.C. BOARD BAD COIL LOOSE OR DAMAGED HARNESSING CLAW HAS MECHANICALLY JAMMED	REPLACE WITH PROPER FUSE REPLACE COIL CHECK W / METER AND REPAIR FIND JAM AND REPAIR
CLAW STAYS CLOSED	BAD DRIVE TRANSISTOR ON MAIN P.C. BOARD CLAW HAS MECHANICALLY LOCKED	REPLACE TRANSISTOR FIND JAM AND REPAIR
AUTO PERCENTAGING IS NOT FUNCTIONING	PROGRAMMING IS NOT CORRECTLY SET BAD PRIZE SENSOR LOOSE OR DAMAGED SENSOR HARNESS	SET OPTIONS "9" AND "17" REPLACE PRIZE SENSOR CHECK W / METER AND REPAIR
CLAW GOES DOWN AND THEN UP BUT DOES NOT CLOSE	DOWN SWITCH BAD LOOSE OR DAMAGED HARNESS TO DOWN SWITCH	REPLACE DOWN SWITCH CHECK W / METER AND REPLACE
CLAW COMES UP AND ABOUT 15 SEC. PASSES BEFORE CRANE MOVES TO THE HOME POSITION	UP SWITCH BAD LOOSE OR DAMAGED HARNESS TO UP SWITCH	REPLACE UP SWITCH CHECK W / METER AND REPLACE
CRANE OR WAGON WHEELS SLIP	MISSING OR DAMAGED O-RING DRIVE BELTS LOOSE SET SCREWS IN WHEELS LOOSE SET SCREWS IN DRIVE COUPLER RAILS NEED TO BE SCUFFED	REPLACE O-RING BELTS TIGHTEN SET SCREWS TIGHTEN SET SCREWS SCUFF TOP OF RAILS WITH SANDPAPER

# QUICK TROUBLESHOOTING

- **NOTE:** A self-test will be performed each time the front door is “closed” or the game is powered up.
- **NOTE:** The game will not count credits or push-out on either the mechanical or software counters while the front door is open.
- **NOTE:** If the Wagon does not move smoothly through a full travel from left to right, check to see that the wheel spacing is correct. If the spacing is correct then check the 2 cabinet rails for burrs that may cause the wheels to bind.
- **NOTE:** If the Crane does not move smoothly through a full travel from front to back, check to see that the wheel spacing is correct. If the spacing is correct then check the 2 cabinet rails for burrs that may cause the wheels to bind.
- **NOTE:** If the micro track for the left to right movement is binding during its travel, check to see if the top mirror bracket’s edge, also the shelf the micro track rides on, has been de-burred.
- **NOTE:** If the front door is having trouble closing fully, check to see that the front light harness is tie wrapped above the highest point of the prize chamber wall. Next, check to see that the prize chamber wall is far enough to the right to allow the right edge of the prize chamber doorframe to swing pass. Finally, check to see that the hinge leaf length is short enough to prevent binding in the cabinet frame.
- **NOTE:** If the door will not lock properly or locks with difficulty, check to see if the lock rotates smoothly. Next, check that the lock rods are not binding on the lock cam or the lock rod guides. Next, check that all friction points have been lubricated with molly grease. Finally, if need be, file the lock rod guides such that the door closes and locks smoothly but be careful not to file out too much, for this may cause the door not to pull tightly to the cabinet as it was intended to do.
- **NOTE:** If the decimals light up on the displays after a self-test, an error has been logged. When the door is in the open position, error codes will be shown on the left display. To advance through the error codes press the drop button.
- **NOTE:** If, at the beginning of the self-test mode, the claw does not drop, one or more of the following may apply: the prize sensor is not working or blocked; the string or string lever is mechanically binding; the up or down switch is sticking or misaligned from its actuator.
- **NOTE:** If claw stays closed it is likely that the diode has blown and the transistor controlling the claw has also blown. Shut off the game immediately and have a new diode (in coil assembly,) and transistor (Q10 on main board,) installed. If the capacitors at C16 and C54 are not removed from the main board, remove them for added protection to the solenoid transistor @ Q10.
- **NOTE:** If claw is jerky while being lowered, it is likely that the up spring is missing or not properly elongated. Another possibility is that the string has mechanically bound on the spool. To fix the string binding, enter programming mode and go to mode 26. By moving the joystick to the left and right you are able to raise and lower the claw mechanism. Move the crane over the prize chute and lower the claw mechanism all the way until it starts to wind up backwards. Reverse the motor direction to raise the claw mechanism and properly rewind the string on the spool. Exit the programming mode and the string should be free of mechanical binding.
- **NOTE:** If the claw stays open, first check for bad fuses on the main board, next check that there are no wires dislodged from the connectors in the harness between the wagon and the crane, the harness between the wagon and the main board, the crane assembly and the wagon assembly. If the problem still exists and no fuses are blown or wires dislodged it is likely that the transistor controlling the voltage to the claw has blown on the main board. Replace main board and have the other main board repaired by electronics.
- **NOTE:** If the crane/wagon in the home position, still tries to move left or back, check to see that the actuators are both present. Check to see that the sensors are present. Next, check to see that the sensors and the actuators are both aligned. Then check to see that the sensor wires are not dislodged from the connectors. Finally replace the sensor, it is likely to be bad.

# GAME REPAIR

**WARNING: ALWAYS REMOVE POWER TO THE GAME BEFORE ATTEMPTING ANY SERVICE, UNLESS NEEDED FOR SPECIFIC TESTING. FAILURE TO OBSERVE THIS PRECAUTION COULD RESULT IN SERIOUS INJURY TO YOURSELF OR OTHERS.**

## TROUBLESHOOTING PHILOSOPHY

To find problems with this game, always first check what should be obvious. See that the game is plugged in, and all of the fuses on the game are good.

Next, check to see that all of the connectors are firmly seated, and that none of the wires have pulled out of them.

When trying to find out if specific components are bad or not, try swapping them with components from another player station to see if the problem moves with the component, or stays where it was. This will help you to know if you have a problem with a specific component, or maybe a problem with either the wiring or the Main P.C. Board. Use extreme caution when using probes or volt-meters if the game is powered up. If checking continuity, it is important to disconnect the harnessing at both ends, as attached they may yield erroneous results.

If P.C. Boards are suspected as the cause of problems, check to see that all I.C. chips are firmly seated on the boards.

## MAIN P.C. BOARD REPLACEMENT

1. Remove all A.C. power from the game.
2. Unlock and open the front door.
3. Remove the 4 mounting screws that secure the main board cover in place.
4. Carefully remove all of the connectors from the P.C. Board.
5. Remove the 4 long plastic hexagon nuts that secure the board to the main board housing.
6. Gently pull the P.C. Board from the mounting studs.
7. Reassemble in the reverse order using a new Main P.C. Board.

## GLASS REPLACEMENT

1. Remove all A.C power from the game.
2. Open the front door and carefully “unzip” the rubber molding. **NOTE:** The rubber molding can be unzipped with a Philips head screwdriver and “PLEDGE”® as a lubricant.
3. Carefully remove all broken glass from the rubber molding channel.
4. Lubricate the zip channel and molding channel all around the opening.
5. Carefully install the new glass starting from the bottom and working your way up both sides simultaneously finishing with the top. **NOTE:** The glass is a tight fit and extreme caution should be used when installing. If difficulty is anticipated or encountered, your local auto glass installer will be familiar with the molding since it is a windshield gasket. Their personnel will be able to successfully install the window for you.
6. Using the window installation tool, “zip” the molding together in a clockwise rotation.

## LENS REPLACEMENT

1. Remove all A.C. power from the game.
2. Unlock and open the front door.
3. Locate the lens housing of broken lens.
4. Remove the three nuts and bolts retaining the lens housing in the top panel.
5. Remove the lens housing, fold back edges and install new lens.
6. Reassemble in reverse order.

# GAME REPAIR

## BULB REPLACEMENT

1. Remove all A.C. power from game.
2. Unlock and open front door.
3. Locate lens housing of bad bulb.
4. Remove the three nuts and bolts retaining the lens housing in the top panel.
5. Remove housing, fold back edge to remove lens.
6. Replace old bulb with new bulb.
7. Reassemble in reverse order.

## PLUSH RETAINER REPLACEMENT

1. Remove all A.C. power from the game.
2. Unlock and open the front door.
3. Carefully unbolt the 6 bolts holding the plush retainer to the play field.
4. Remove the old plush retainer.
5. Reassemble in reverse order using new plush retainer.

## REMOVAL OF CRANE MECHANISM

1. Remove all A.C. power from the game.
2. Unlock and open the front door.
3. Slide the crane assembly to the front center of the crane.
4. Loosen black thumbscrew securing the front to back micro track bracket in place. (The thumbscrew is located on the front face of the crane assembly nearest the door.)
5. Slide the micro track bracket forward and up to disconnect it from the crane assembly.
6. Carefully lift the entire crane assembly off the rails approximately 2 inches, shift to the left as far as possible, drop the right side down past the right crane rail and slide the entire assembly out from between the two separator rails.
7. The crane assembly can now be removed from the cabinet so necessary maintenance / repairs can be made.
8. Reassemble in reverse order.

## REMOVAL OF WAGON MECHANISM

1. Remove all A.C. power from game.
2. Unlock and open the front door.
3. Remove crane assembly as detailed previously.
4. Loosen black thumbscrew securing the micro track bracket in place. (The thumbscrew is located on the upper right face of the wagon assembly.)
5. Slide the micro track bracket to the right and up to disconnect it from the wagon assembly.
6. Carefully lift the entire wagon assembly off the rails and rotate clockwise until the left front wheel clears the front rail.
7. Lower the front of the wagon assembly and remove the assembly from between the two rails.
8. The wagon assembly can now be removed from the cabinet so necessary maintenance / repairs can be made.
9. Reassemble in reverse order.

## PRIZE SENSOR REPLACEMENT

1. Remove all A.C. power from the game.
2. Unlock and open the front door.
3. Remove the connector from the prize sensor board.
4. Remove the 3 plastic hexagonal nuts securing the sensor board to the bracket.
5. Carefully remove the sensor board from its mounting studs
6. Reassemble in reverse order using a new prize sensor board.

# GAME REPAIR

## STRING REPLACEMENT

1. Remove all A.C. power from the game.
2. Unlock and open the front door.
3. Remove crane assembly as detailed previously.
4. Disconnect the claw assembly from the crane assembly by removing the two bolts securing the aluminum coil cap to the coil housing.
5. Take the replacement string and tie a knot at one end.
6. Using a lighter, melt the other end of the string and form a point before it completely cools.
7. Feed the pointed string end up through the hole in the coil cap and pull until the knot is firmly seated on the inside of the cap.  
SEE CRANE ASSEMBLY DIAGRAM AND STRING ROUTING DIAGRAM
8. Feed the pointed end up through the hole in the bottom of the crane assembly housing.
9. Feed string over first string guide then under second string guide.
10. Finally feed the string through the hole in the side of the string spool, (attached to the motor shaft,) and tie another knot.
11. String is now properly strung.
12. Reattach the claw assembly to the crane assembly using the two bolts that were removed in step 4.
13. Reinstall the crane assembly into the game and set it in the home position with the claw assembly hanging in the prize chute.
14. Turn on the game and the crane will automatically rewind the string properly.

## MOTOR REPLACEMENT

1. Remove all A.C. power from the game.
2. Unlock and open the front door.
3. Remove crane and or wagon assembly as detailed previously. **NOTE:** What is removed depends on which motor has gone bad.

4. Loosen two thumbscrews securing crane housing cap in place and remove. **NOTE:** This step is only for the two motors in the crane assembly.
5. Remove drive o-rings and wheels from the bad motor.
6. De-solder the motor leads from the bad motor. **NOTE:** Be sure to note which wire goes to which motor lead, for if they are reinstalled backwards the motor will run in the opposite of its intended direction.
7. Carefully remove bronze bushing supporting the motor shaft of the bad motor. **NOTE:** This step is only for the two motors in the crane assembly.
8. Remove the 4 bolts securing the motor to the housing.
9. Carefully remove the bad motor.
10. Reassemble in reverse order using new motor. **NOTE:** When motor is completely reinstalled, place one drop of thread lock on each of the 4 bolts that secure the motor in place to prevent the bolts from backing out.

## FUSE REPLACEMENT

CAUTION FOR CONTINUED PROTECTION AGAINST RISK OF FIRE, REPLACE ONLY WITH THE SAME TYPE OF FUSE HAVING THE SAME ELECTRICAL RATING.

<u>AREA</u>	<u>LOCATION</u>	<u>AMP</u>	<u>VOLT</u>
MAIN BOARD	F2	6 MDQ	250
	F3	3 MDQ	250
	F4	4 MDQ	250
	F5	4 MDQ	250
POWER MOD	—	3 MDQ	250

## CORD REPLACEMENT

IF THE SUPPLY CORD IS DAMAGED, IT MUST BE REPLACED BY THE MANUFACTURER OR ITS SERVICE AGENT OR A SIMILARLY QUALIFIED PERSON, IN ORDER TO AVOID A HAZARD.

# PARTS LISTINGS

## MECHANICAL PARTS

5011 SPRING  
 CG1001 LEFT FRONT CORNER  
 CG1002 RIGHT FRONT CORNER  
 CG1003 REAR CORNER  
 CG1004 TOP FRONT PANEL  
 CG1005 BOTTOM FRONT PANEL  
 CG1006 CABINET DOOR  
 CG1007 PRIZE DOOR  
 CG1008 SIDE PANEL  
 CG1013 LOCK CAM  
 CG1014 UPPER LOCK ROD  
 CG1015 LOWER LOCK ROD  
 CG1018 PODIUM  
 CG1020 FRONT CABINET RAIL  
 CG1031 REAR CABINET RAIL  
 CG1036 MAIN PCB COVER  
 CG1052 3" SWIVEL CASTER  
 CG1055X WAGON ASSEMBLY  
 CG1061X CRANE ASSEMBLY  
 CG1054 WAGON ROLLER SHAFT  
 CG1069X TRACK MOUNT RAIL ASSEMBLY  
 CG2008 MOTOR / GEARBOX  
 CG3019 THUMB SCREW  
 CG3030 WHEEL  
 CG4003 O – RING DRIVE BAND  
 CG1062 CRANE MOTOR HOUSING CAP  
 CG1066 CRANE UP SPRING  
 CG1070 COIL HOUSING  
 CG1073 COIL SLIDER  
 CG1075 COIL PLUNGER  
 CG1078A SMALL CLAW  
 CG1078B MEDIUM CLAW  
 CG1078D JUMBO CLAW  
 CG3036 COIL CLAW INTERCONNECT  
 CG3037 CLAW SPIDER  
 CG4004 SPRING  
 CG3006 CLEAR LENS  
 CG2014 JOYSTICK  
 CG3008 MICRO TRACK 56 LINK  
 CG3009 MICRO TRACK 35 LINK  
 CG3013 COIN FUNNEL  
 CG3026 MIRROR  
 CG3027 FRONT GLASS  
 CG3028 SIDE GLASS  
 CG4001 WINDOW GASKET  
 CG4014 LOCK T – HANDLE  
 CG5015 LOCK BARREL  
 CG9001 SERVICE MANUAL  
 CG9010 FAN SHROUD  
 CG5001 WINDOW INSTALLATION TOOL

## DECALS

CG7001 DECAL PRIZE DOOR  
 CG7002 DECAL STOP SIGN  
 CG7003 DECAL CORNER STREET  
 CG7006 DECAL BUMPER  
 CG7007 DECAL SIDE MARQUEE  
 CG7008 DECAL FRONT STREET  
 CG7009 DECAL TIRE / STREET  
 CG7010 DECAL SIDE / ICE LOGO  
 CG7012 DECAL PODIUM  
 CG7013 DECAL CONTROL PANEL JOY  
 CG7015 DECAL CONTROL PANEL BUTTONS  
 CG7027 DECAL FRONT MARQUEE

## ELECTRICAL PARTS

2027 FAN  
 2132 GE BRIGHT STICK  
 2970 DOOR SWITCH  
 AR2007 6X9 SPEAKER  
 2388 CAP 1.0 UF 10% 100V  
 CG2012 F/B, UP, DOWN SENSOR  
 CG2013 L/R SENSOR  
 CG2010 F/B, UP, DOWN ACTUATOR  
 CG2011 L/R ACTUATOR  
 2933 MINI 12 PIN PLUG  
 2935 MINI 15 PIN PLUG  
 CG3038X SOLENOID ASSEMBLY  
 CG2002 TRANSFORMER  
 CG2006 RED LIGHT  
 CG2032X DISPLAY PCB  
 CG2034X MAIN PCB  
 2080 BRIDGE RECT. 10 AMP 400V  
 208004 VOLTAGE REG IC LM 338K  
 2110 TRANSISTOR TIP 122  
 2124 VOLTAGE REG IC LM 585  
 CG2039X PRIZE SENSOR PCB  
 HD20224 5V COUNTER  
 CG2600 DBV MARS SERIES 2000

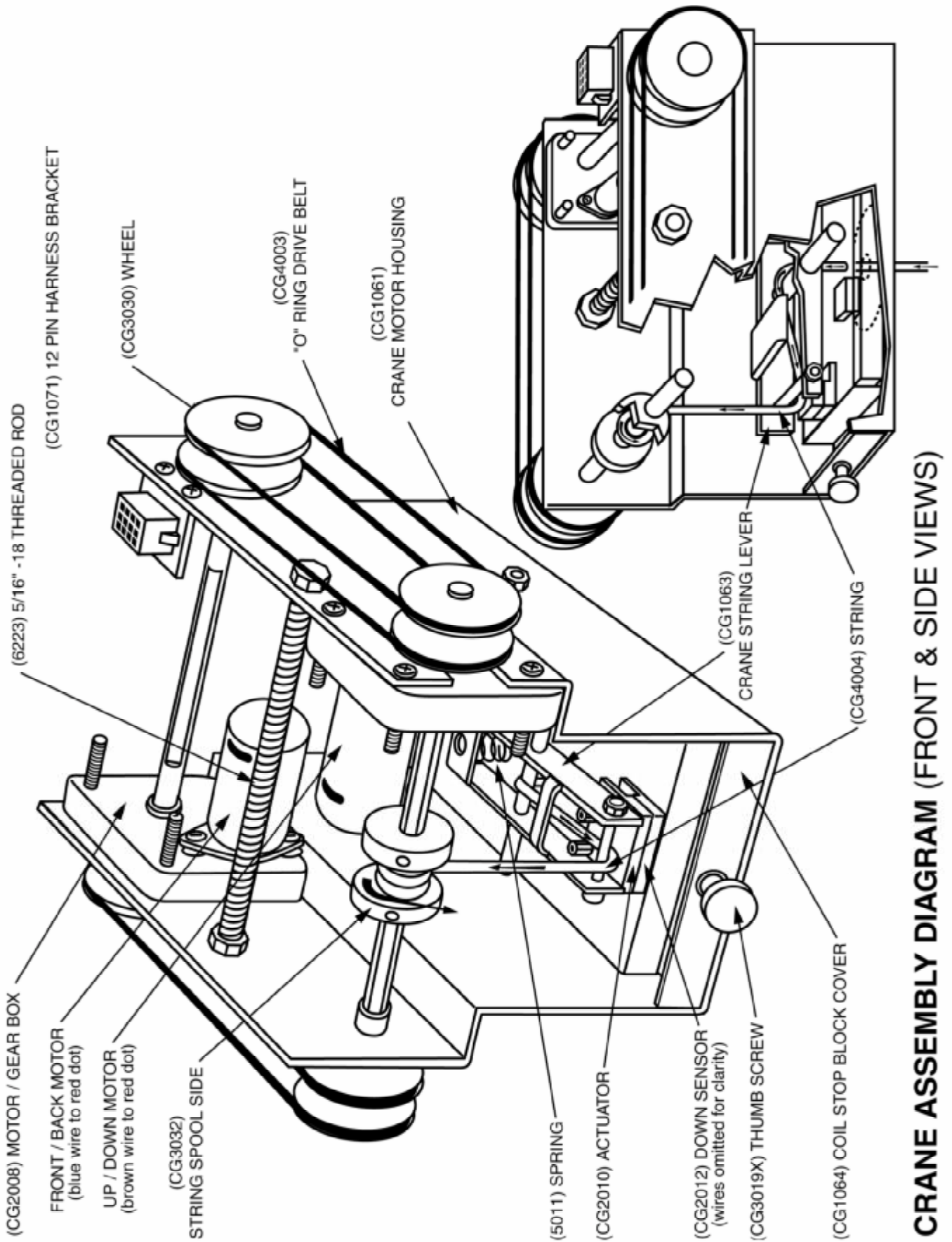

**CRANE ASSEMBLY DIAGRAM (FRONT & SIDE VIEWS)**

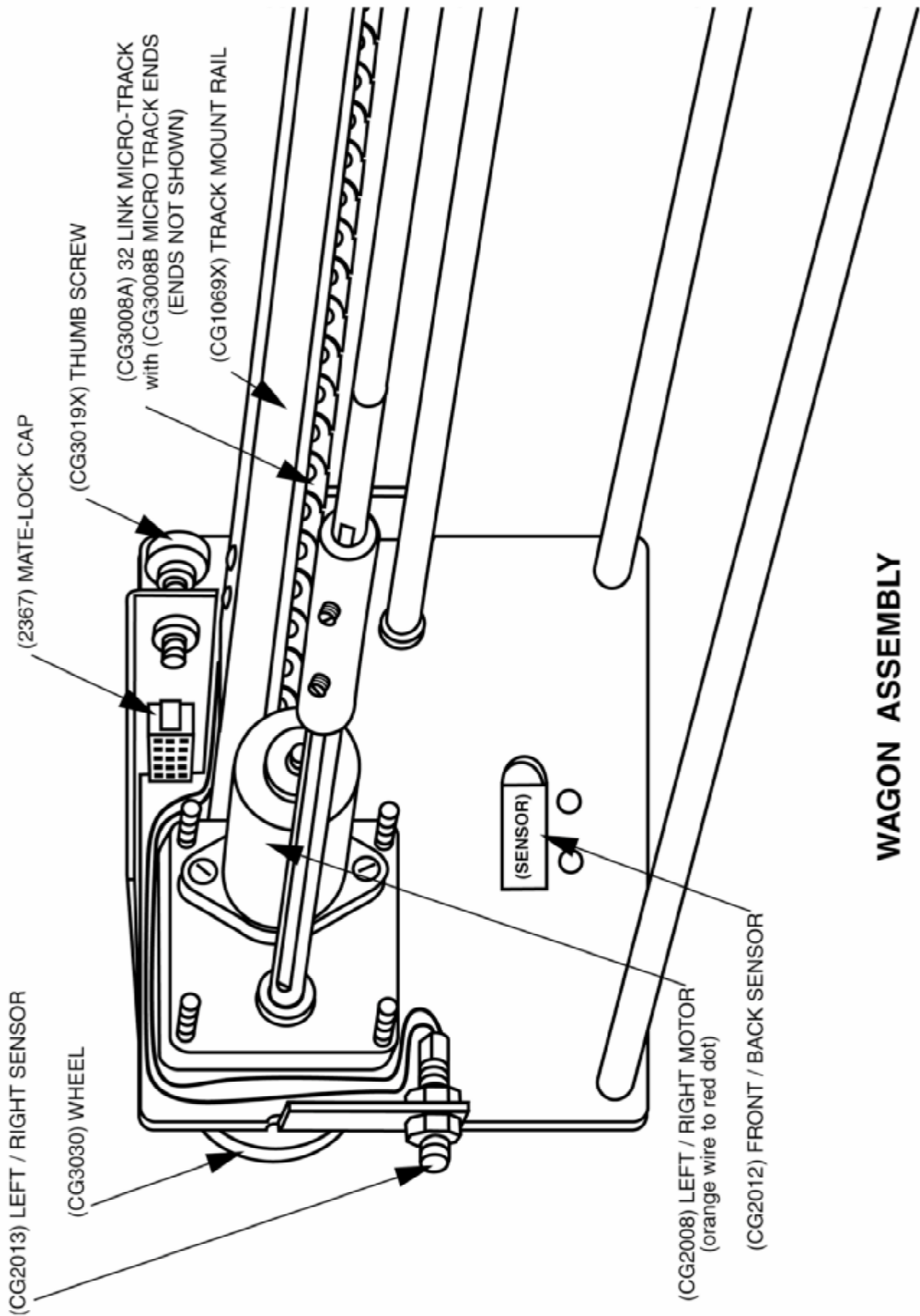



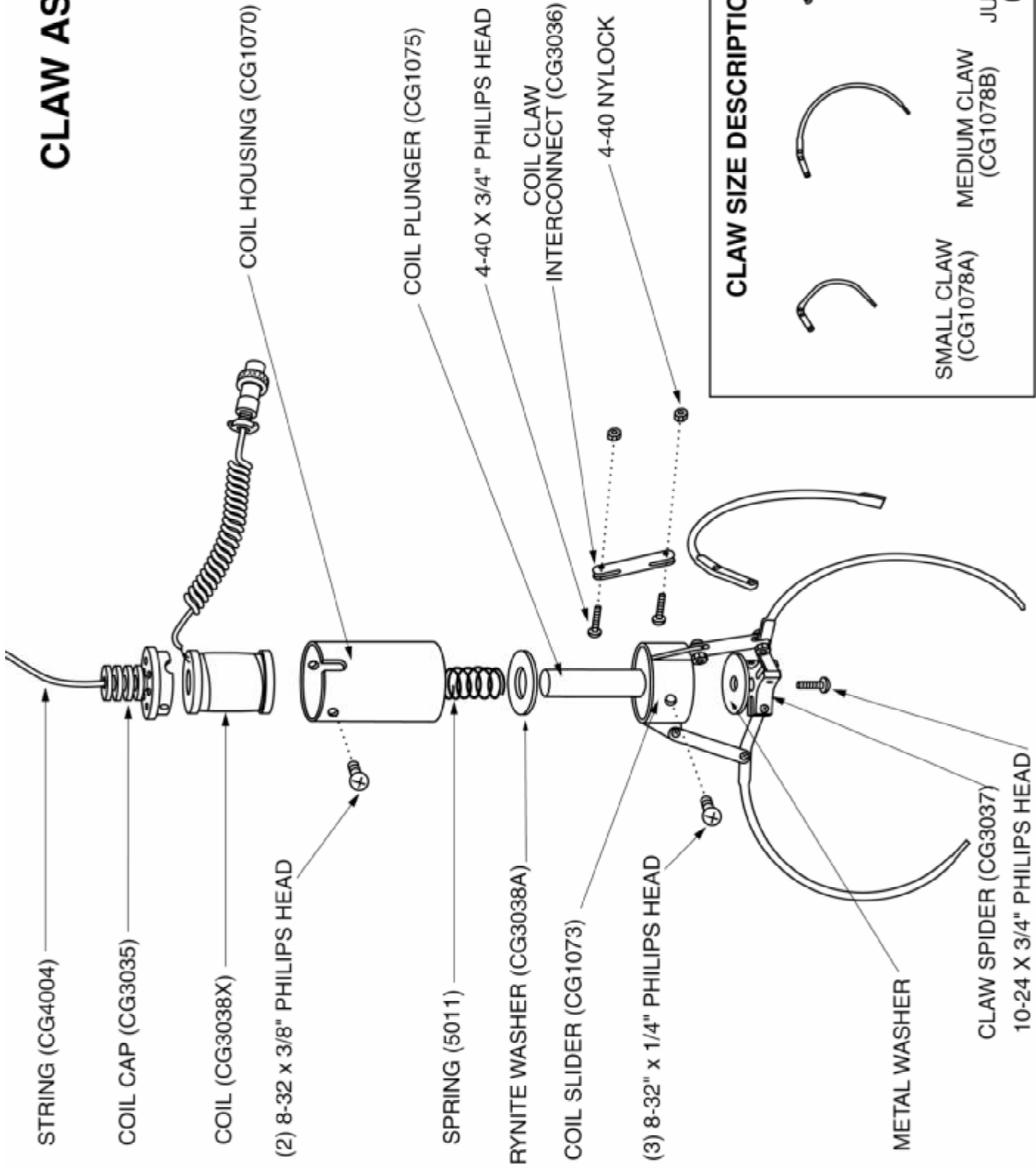

# CLAW ASSEMBLY



**CLAW SIZE DESCRIPTIONS**

		
SMALL CLAW (CG1078A)	MEDIUM CLAW (CG1078B)	JUMBO CLAW (CG1078D)

# STRING ROUTING DIAGRAM

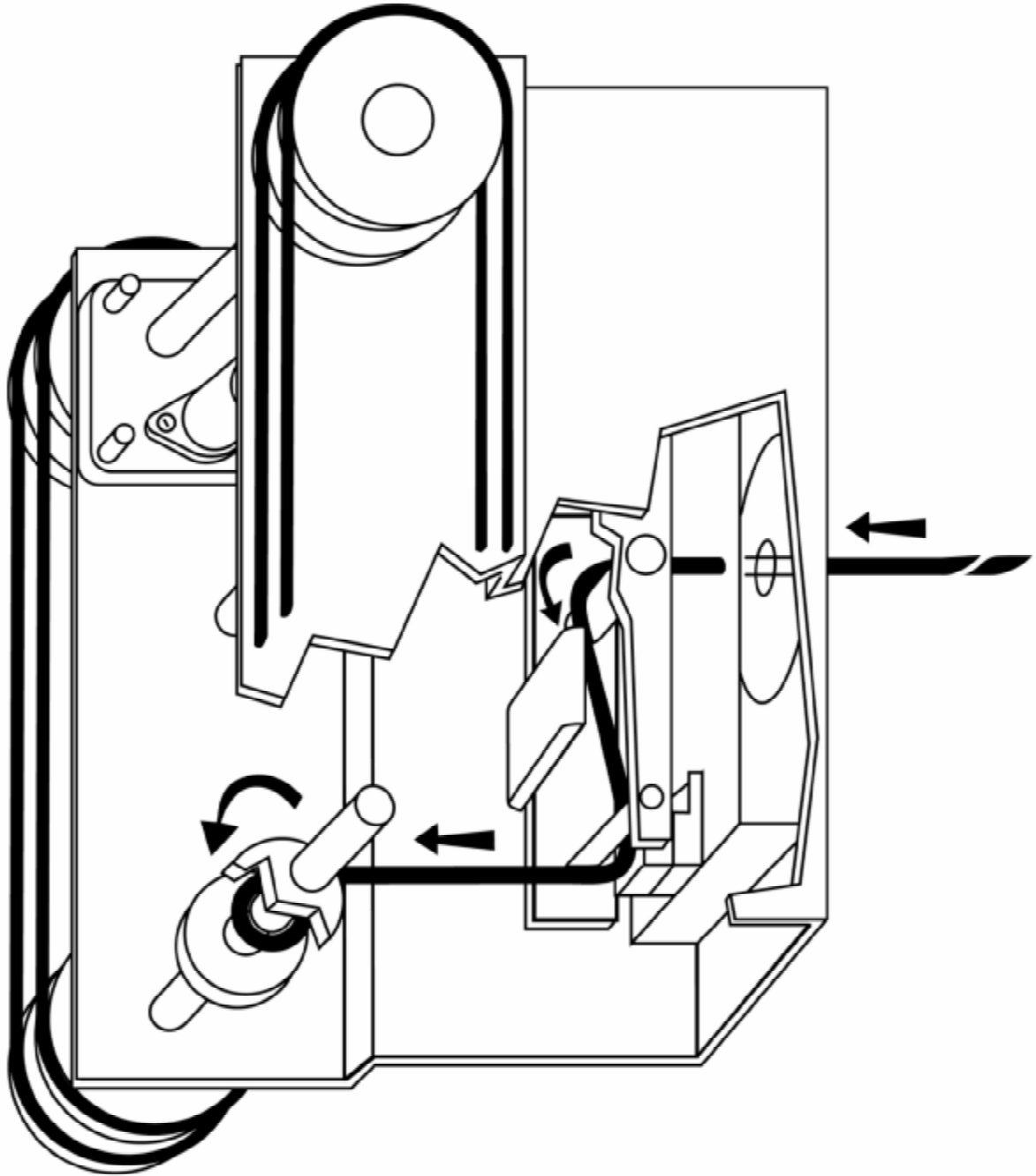

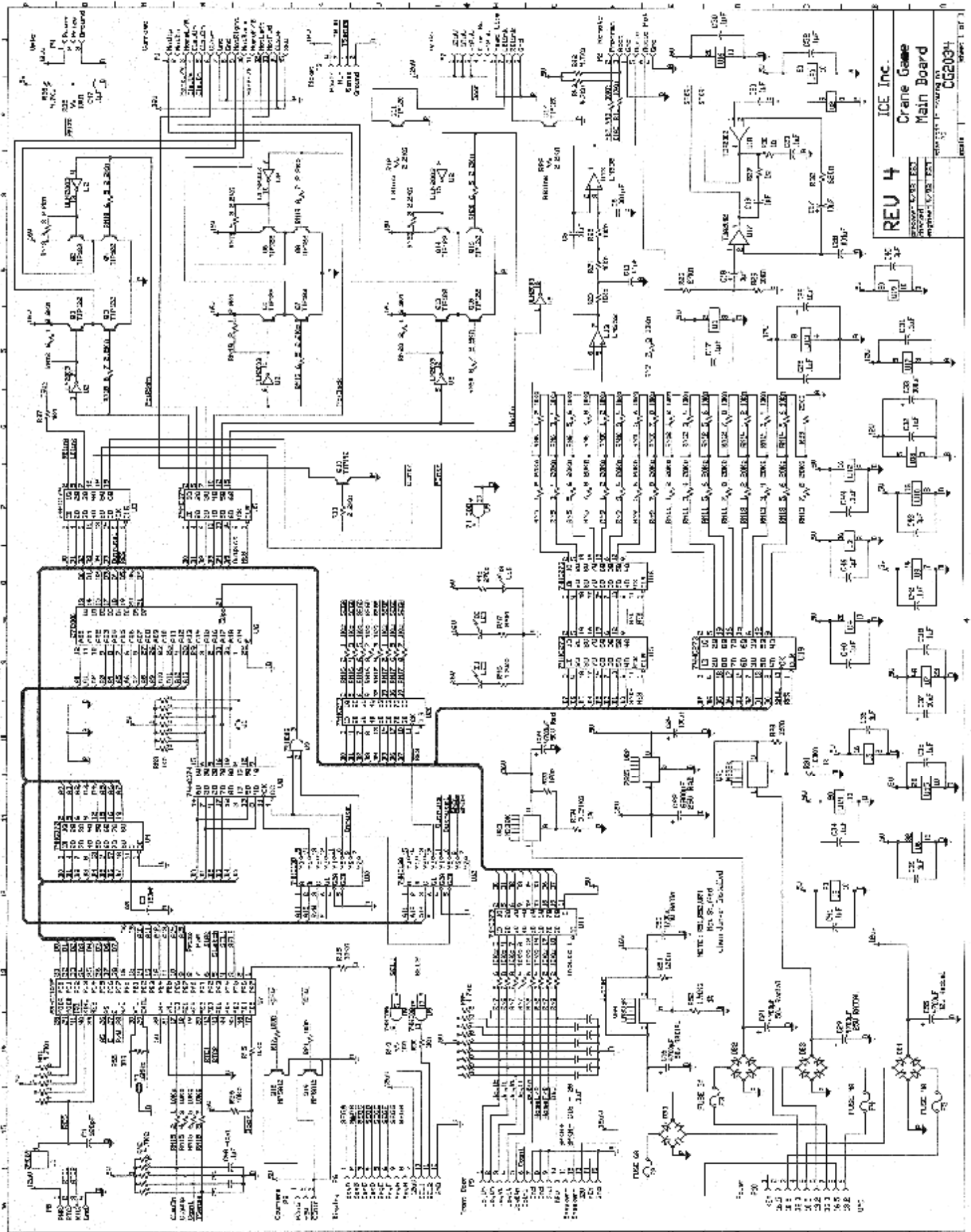

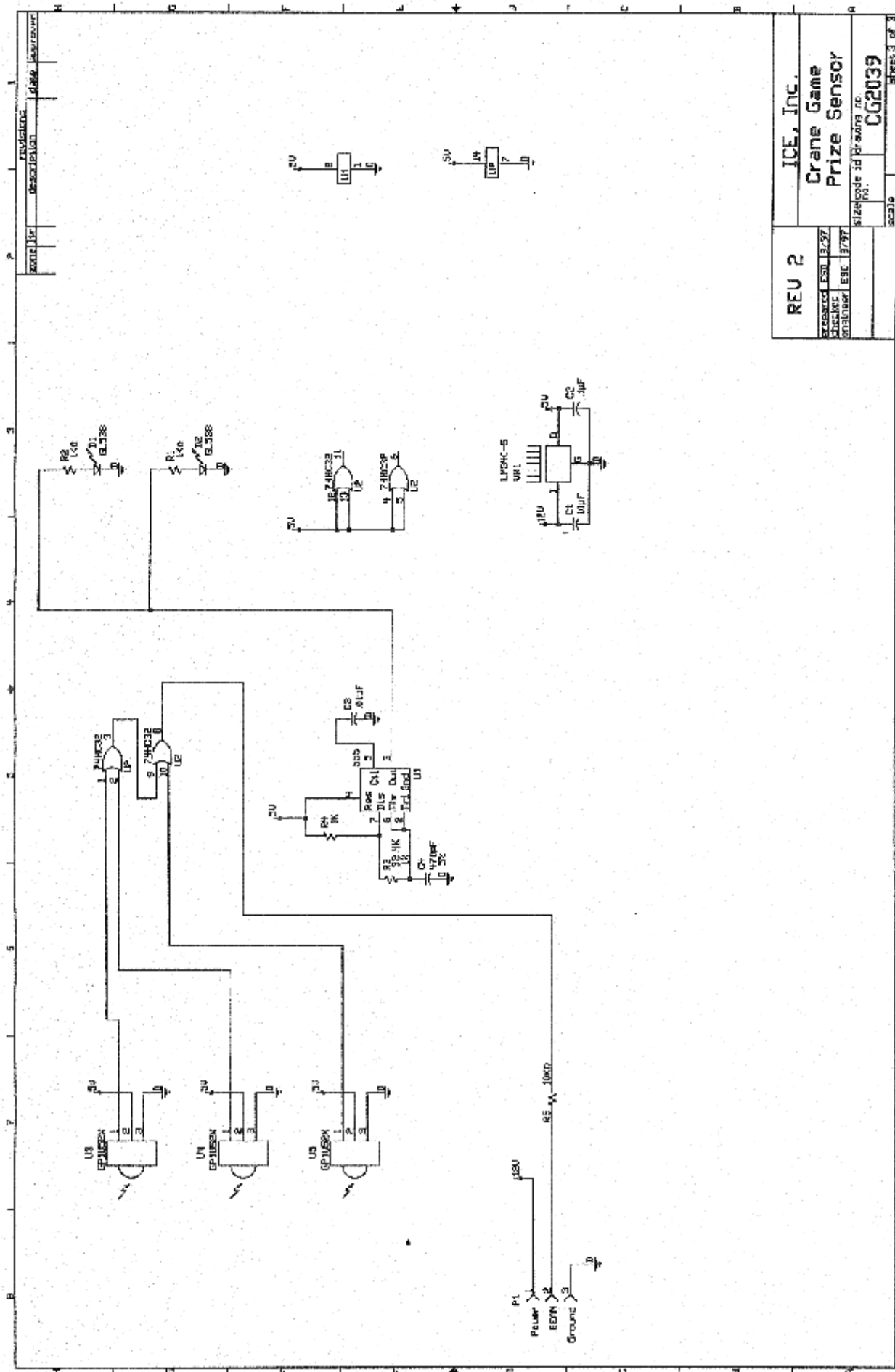

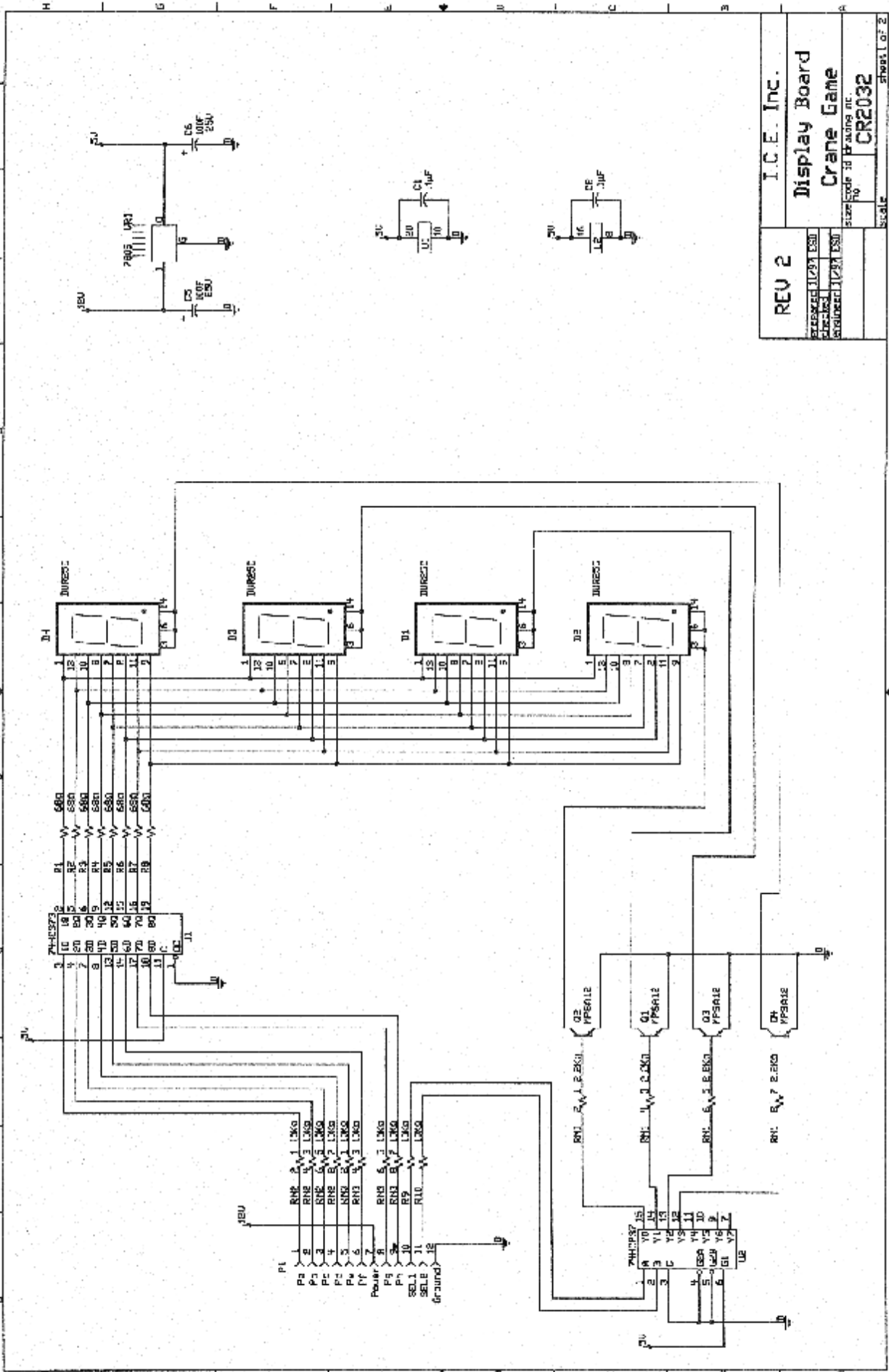

REV 2		I.C.E. Inc.	
DESIGNED BY	CR2032	Display Board	
CHECKED BY		Crane Game	
ASSEMBLED BY		I.C.E. Inc.	
DATE		Scale	
		Sheet 1 of 2	

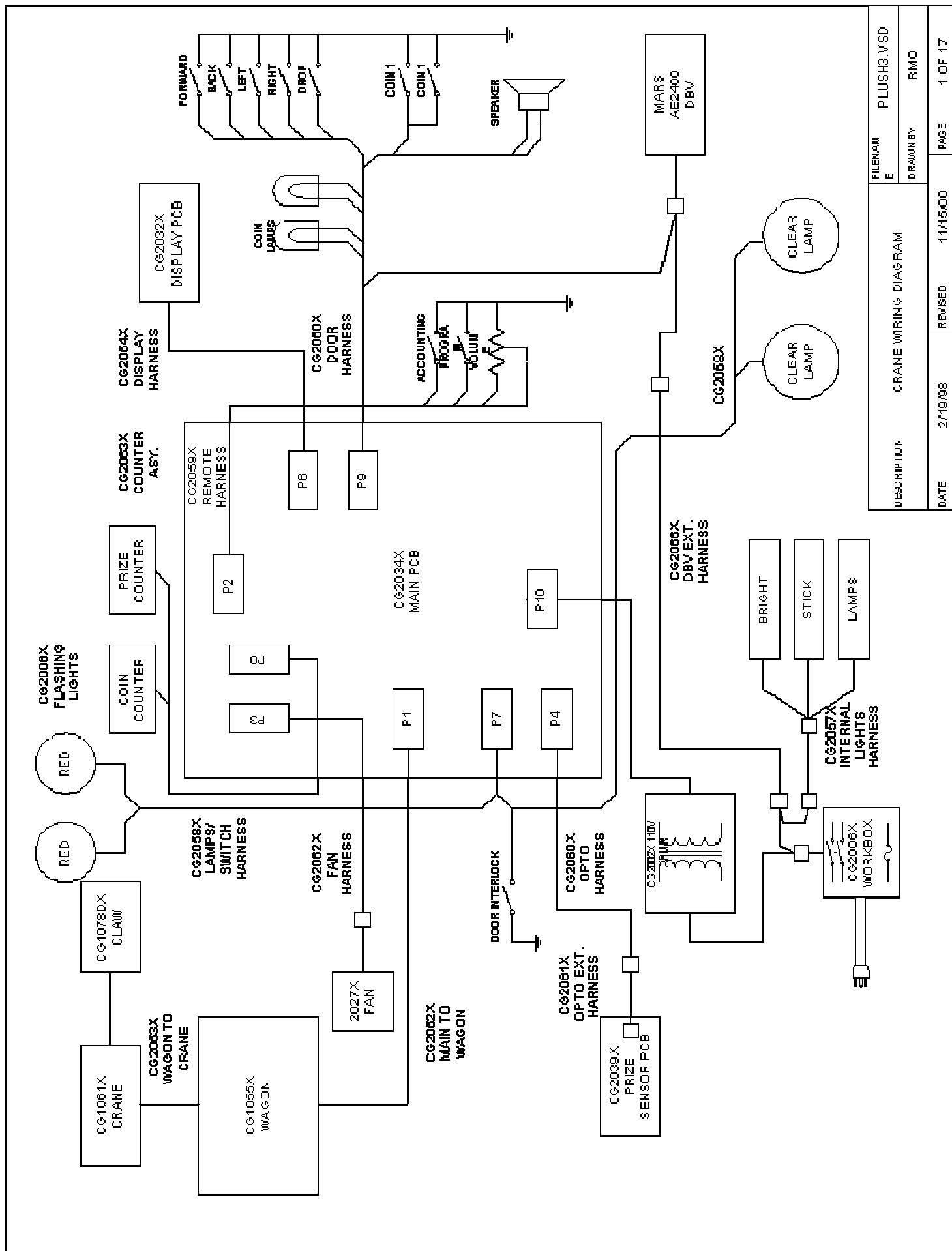

DESCRIPTION	CRANE WIRING DIAGRAM	FILENAME	PLUS3.VSD
DATE	2/19/98	DRAWN BY	RMO
REVISION	11/15/00	PAGE	1 OF 17

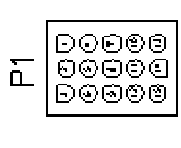

- P1 CARRAGE**
1. MOTOR UP
  2. MOTOR DOWN
  3. HOME LEFT / RIGHT SENSOR
  4. CLAW UP SENSOR
  5. CLAW DOWN SENSOR
  6. CLAW CLOSE (CLAW -)
  7. GROUND
  8. GROUND
  9. MOTOR RIGHT
  10. MOTOR BACK
  11. HOME FRONT / BACK SENSOR
  12. MOTOR LEFT
  13. MOTOR FORWARD
  14. CLAW POWER (CLAW +)
  15. 36V

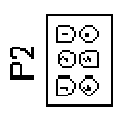

- P2 REMOTE**
1. GROUND
  2. PROGRAM BUTTON
  3. ACCOUNTING
  4. GROUND
  5. AUDIO TOP
  6. AUDIO WIPER

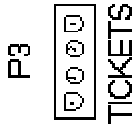

- P3 TICKETS**
1. TICKET SENSE
  2. GROUND
  3. TICKET RUN
  4. 12 VOLTS

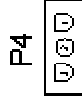

- P4 PRIZE SENSOR**
1. 12 VOLTS
  2. PRIZE SENSOR
  3. GROUND

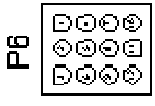

- P6 DISPLAY**
1. SEGMENT A
  2. SEGMENT B
  3. SEGMENT C
  4. SEGMENT D
  5. SEGMENT E
  6. SEGMENT F
  7. 12 VOLTS
  8. SEGMENT H
  9. SEGMENT G
  10. SELECT 1
  11. SELECT 2
  12. GROUND

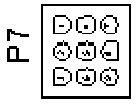

- P7 LIGHTS**
1. 12 VOLTS
  2. 12 VOLTS
  3. 12 VOLTS
  4. DOOR SWITCH
  5. 12 VOLTS
  6. HEADLIGHTS
  7. LEFT BLINKER
  8. RIGHT BLINKER
  9. GROUND

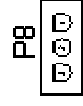

- P8 COUNTERS**
1. PRIZE COUNTER
  2. 5 VOLTS
  3. MCOIN / CREDIT COUNTER

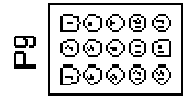

- P9 DOOR**
1. JOYSTICK UP
  2. JOYSTICK DOWN
  3. JOYSTICK RIGHT
  4. JOYSTICK LEFT
  5. JOYSTICK BUTTON
  6. COIN INPUT
  7. GROUND
  8. GROUND
  9. GROUND
  10. DOLLAR BILL VALIDATOR
  11. SPEAKER +
  12. SPEAKER -
  13. 12 VOLTS
  14. KEY
  15. GROUND

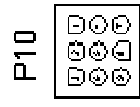

- P10 POWER**
1. KEY
  2. 16 VAC
  3. 10 VAC
  4. 36 VAC
  5. 10 VAC
  6. 13 VAC
  7. 36 VAC
  8. 16 VAC
  9. 13 VAC

TITLE		FILENAME	FLUSHES/VSD
DESCRIPTION	CRANE MAIN BOARD CONNECTOR PIN OUT		RMD
DATE	2/19/98	REVISED	11/15/00
		PAGE	2 OF 17

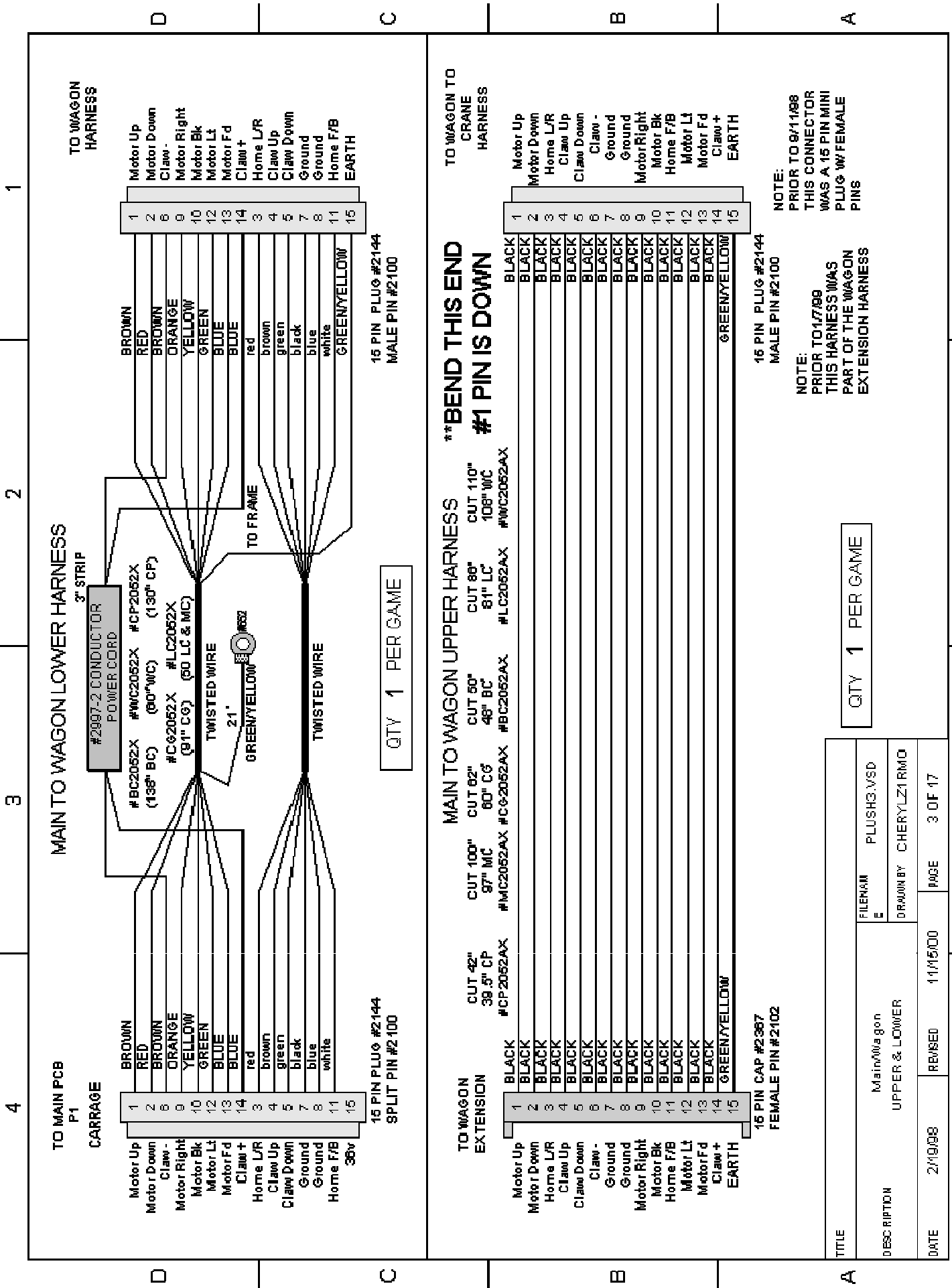

**\*\*BEND THIS END #1 PIN IS DOWN**

**MAIN TO WAGON UPPER HARNESS**

1	BLACK	CUT 110"
2	BLACK	CUT 80"
3	BLACK	CUT 50"
4	BLACK	CUT 60"
5	BLACK	CUT 80"
6	BLACK	CUT 110"
7	BLACK	CUT 80"
8	BLACK	CUT 50"
9	BLACK	CUT 60"
10	BLACK	CUT 80"
11	BLACK	CUT 110"
12	BLACK	CUT 80"
13	BLACK	CUT 50"
14	BLACK	CUT 60"
15	GREEN/YELLOW	CUT 110"

**TO WAGON EXTENSION**

1	BLACK	CUT 100"
2	BLACK	CUT 82"
3	BLACK	CUT 50"
4	BLACK	CUT 60"
5	BLACK	CUT 80"
6	BLACK	CUT 110"
7	BLACK	CUT 80"
8	BLACK	CUT 50"
9	BLACK	CUT 60"
10	BLACK	CUT 80"
11	BLACK	CUT 110"
12	BLACK	CUT 80"
13	BLACK	CUT 50"
14	BLACK	CUT 60"
15	GREEN/YELLOW	CUT 110"

**15 PIN CAP #2367 FEMALE PIN #2102**

**15 PIN PLUG #2144 MALE PIN #2100**

**15 PIN PLUG #2144 MALE PIN #2100**

**NOTE:**  
PRIOR TO 9/11/88 THIS CONNECTOR WAS A 15 PIN MINI PLUG W/ FEMALE PINS

**NOTE:**  
PRIOR TO 1/7/99 THIS HARNESS WAS PART OF THE WAGON EXTENSION HARNESS

**QTY 1 PER GAME**

TITLE	Main/Wagon UPPER & LOWER		FILENAM	PLUS3.VSD
DESC RPTDN	UPPER & LOWER		DRAWN BY	CHERYLZ1RMD
DATE	2/19/98	REVISED	11/15/00	PAGE 3 OF 17



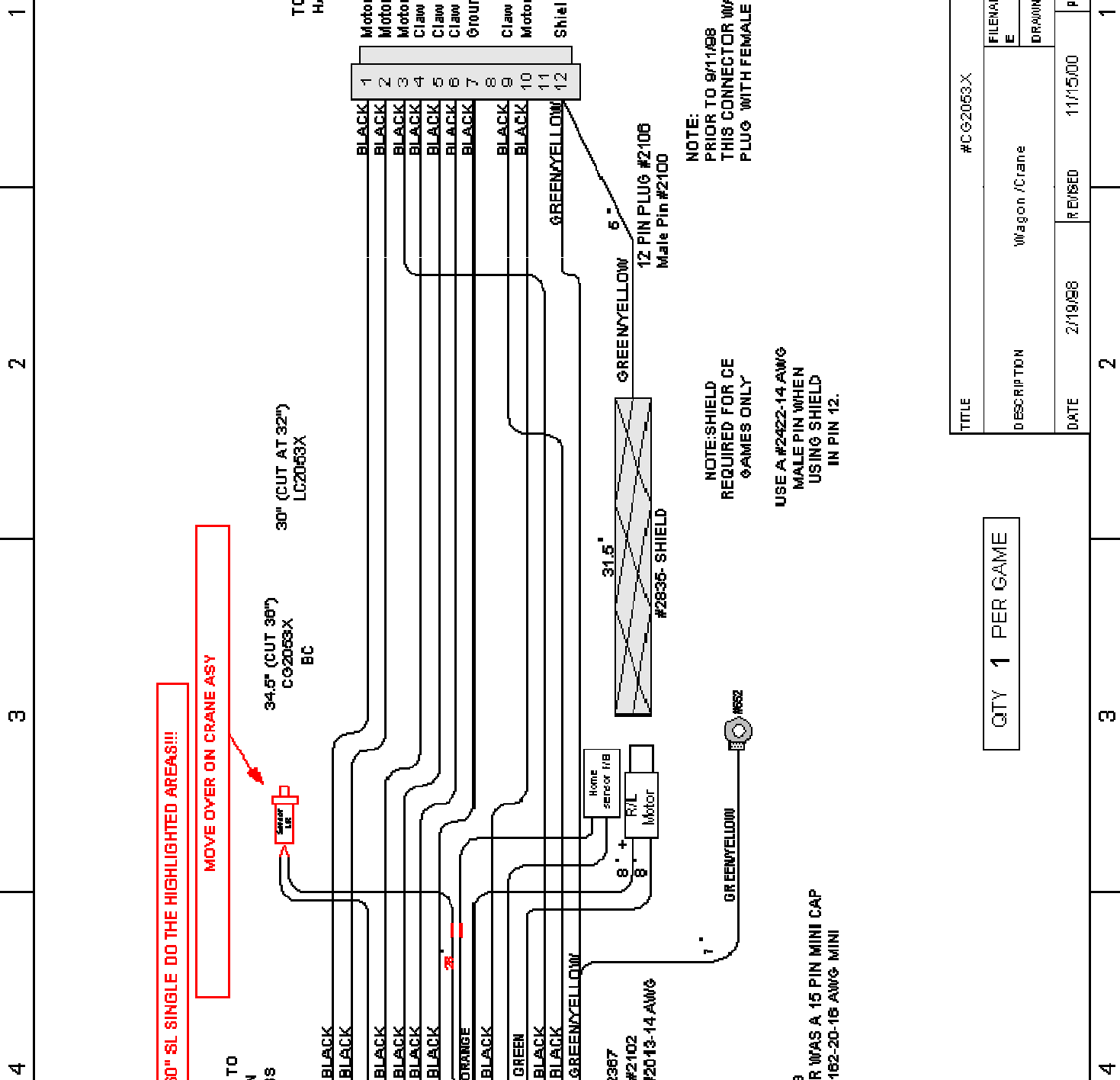

FOR 60" SL SINGLE DO THE HIGHLIGHTED AREAS!!!

MOVE OVER ON CRANE ASY

TO MAIN TO WAGON HARNESS

34.5" (CUT 36") C-02053X BC

30" (CUT AT 32") LC2053X

- 1 BLACK Motor Up
- 2 BLACK Motor Down
- 3 BLACK Home L/R
- 4 BLACK Claw Up
- 5 BLACK Claw Down
- 6 BLACK Claw -
- 7 BLACK Ground
- 8 ORANGE Ground
- 9 BLACK Motor Right
- 10 BLACK Motor Bk
- 11 GREEN Home F/B
- 12 BLACK Motor Lt.
- 13 BLACK Motor Fd.
- 14 BLACK Claw +
- 15 GREEN/YELLOW Shield

- 1 BLACK Motor Up
- 2 BLACK Motor Down
- 3 BLACK Motor Fd.
- 4 BLACK Claw Up
- 5 BLACK Claw Down
- 6 BLACK Claw -
- 7 BLACK Ground
- 8 BLACK Claw +
- 9 BLACK Motor Bk
- 10 BLACK Motor Lt.
- 11 BLACK Motor Fd.
- 12 GREEN/YELLOW Shield

15 PIN CAP #2367 FEMALE PIN #2102 PIN #15 USE #2013-14 AWG

31.5" #2835- SHIELD

12 PIN PLUG #2106 Male Pin #2100

NOTE: SHIELD REQUIRED FOR CE GAMES ONLY

NOTE: PRIOR TO 9/1/98 THIS CONNECTOR WAS A 15 PIN MINI CAP W/ MALE PINS #8162-20-16 AWG MINI

NOTE: #2422-14 AWG MALE PIN WHEN USING SHIELD IN PIN 12.

NOTE: PRIOR TO 9/1/98 THIS CONNECTOR WAS A 12 PIN MINI PLUG WITH FEMALE PINS #8163-MINI

QTY 1 PER GAME

TITLE	#CG2053X	
DESCRIPTION	Wagon /Crane	FILENAM PLUS3.VSD
DATE	2/19/98	DR-0001 BY CHERYLZ/RMD
REVISED	11/15/00	PAGE 4 OF 17

1 2 3 4

D C B A

TO WAGON TO  
CRANE  
HARNES

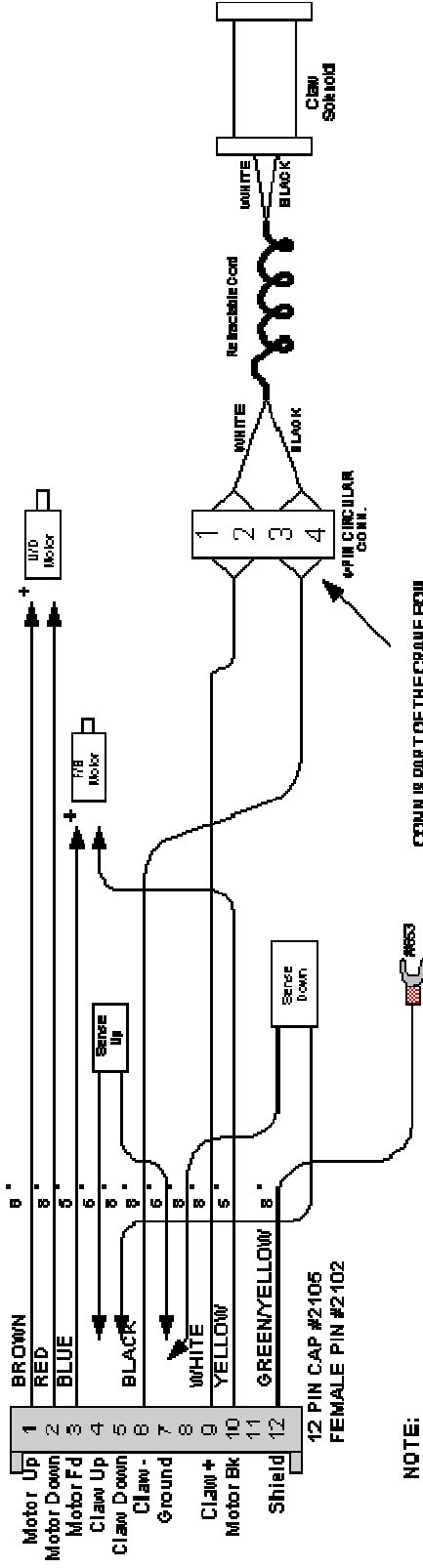

NOTE:  
PRIOR TO 9/11/08  
THIS CONNECTOR  
WAS A 12 PIN MINI  
CAP WITH MALE PINS

NOTE:  
CONN IS PART OF THE CRANE BOOM  
SUBSARY SOLDER THE WIRES FOR  
THE MOTORS DIRECT AND ADDS THE  
PINS ON THE SENSORS MAKING THOSE  
PARTS PART OF THE CRANE BOOM

TITLE	#CG2056X	
DESCRIPTION	Crane	FILENAME PLUS3.VSD
DATE	2/19/98	DRAWN BY CHERYLZ1 RMO
REVISED	11/15/00	PAGE 5 OF 17

QTY 1 PER GAME

1 2 3 4

D C B A

1  
2  
3  
4

D C B A

#C 02059X-REMOTE  
HARNES

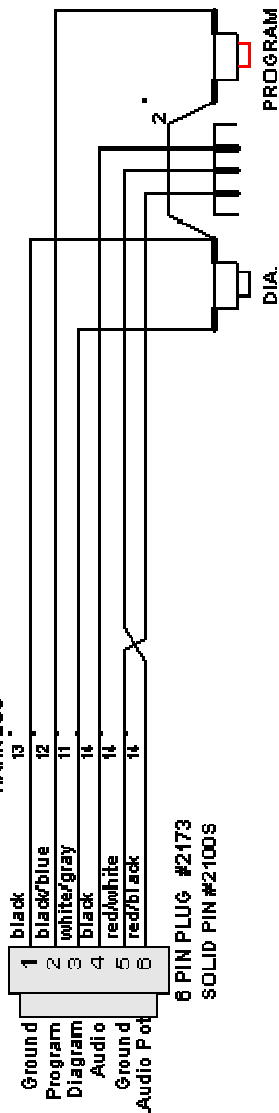

#C 02059X

TITLE	REMOTE ASSEMBLY		FILENAM E	PLUS3.VSD
DESCRIPTION	REMOTE ASSEMBLY		DRAWN BY	CHERYLZ1CMZ
DATE	2/19/98	REVISED	11/15/00	PAGE 6 OF 17

QTY 1 PER GAME

4  
3  
2  
1

D C B A

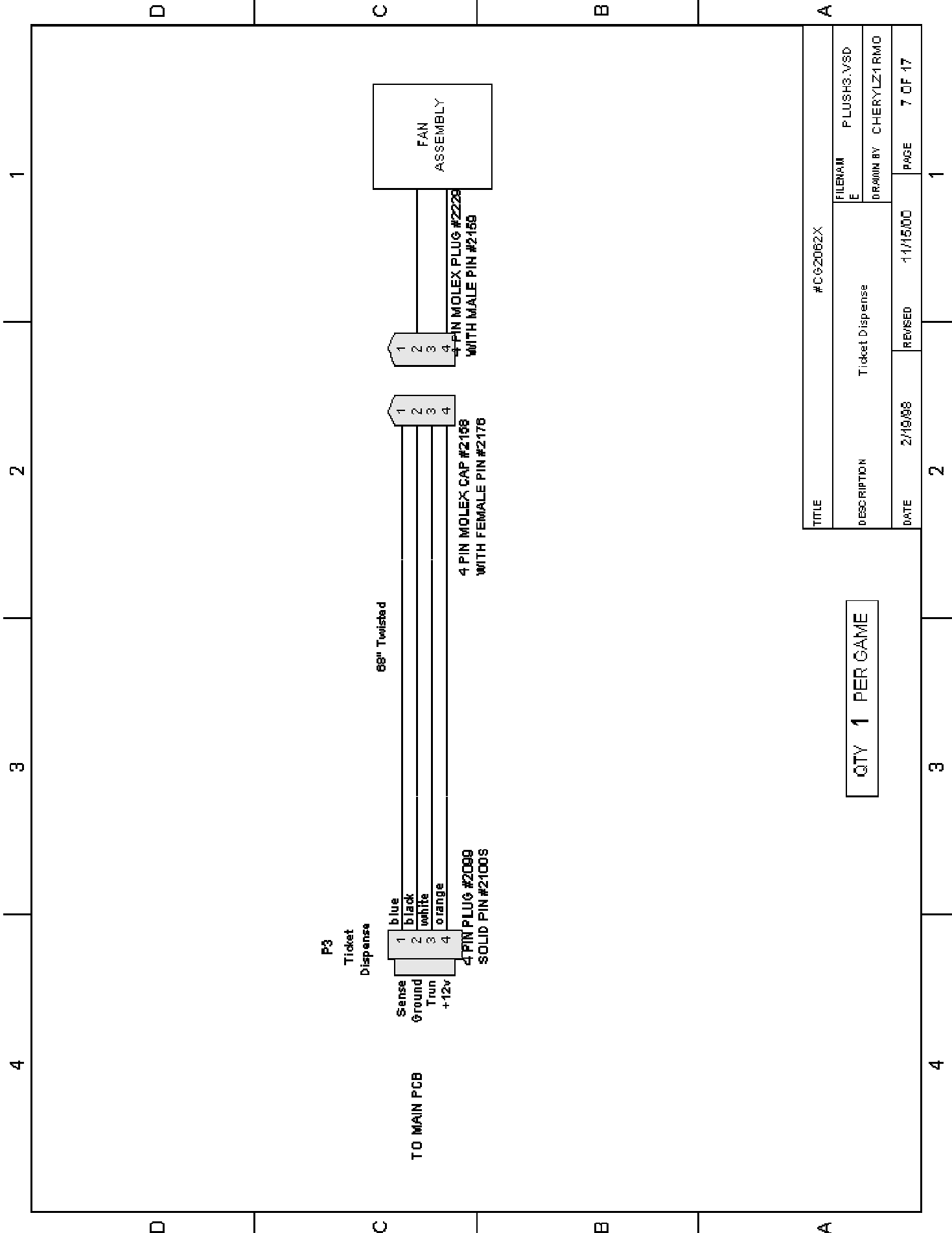

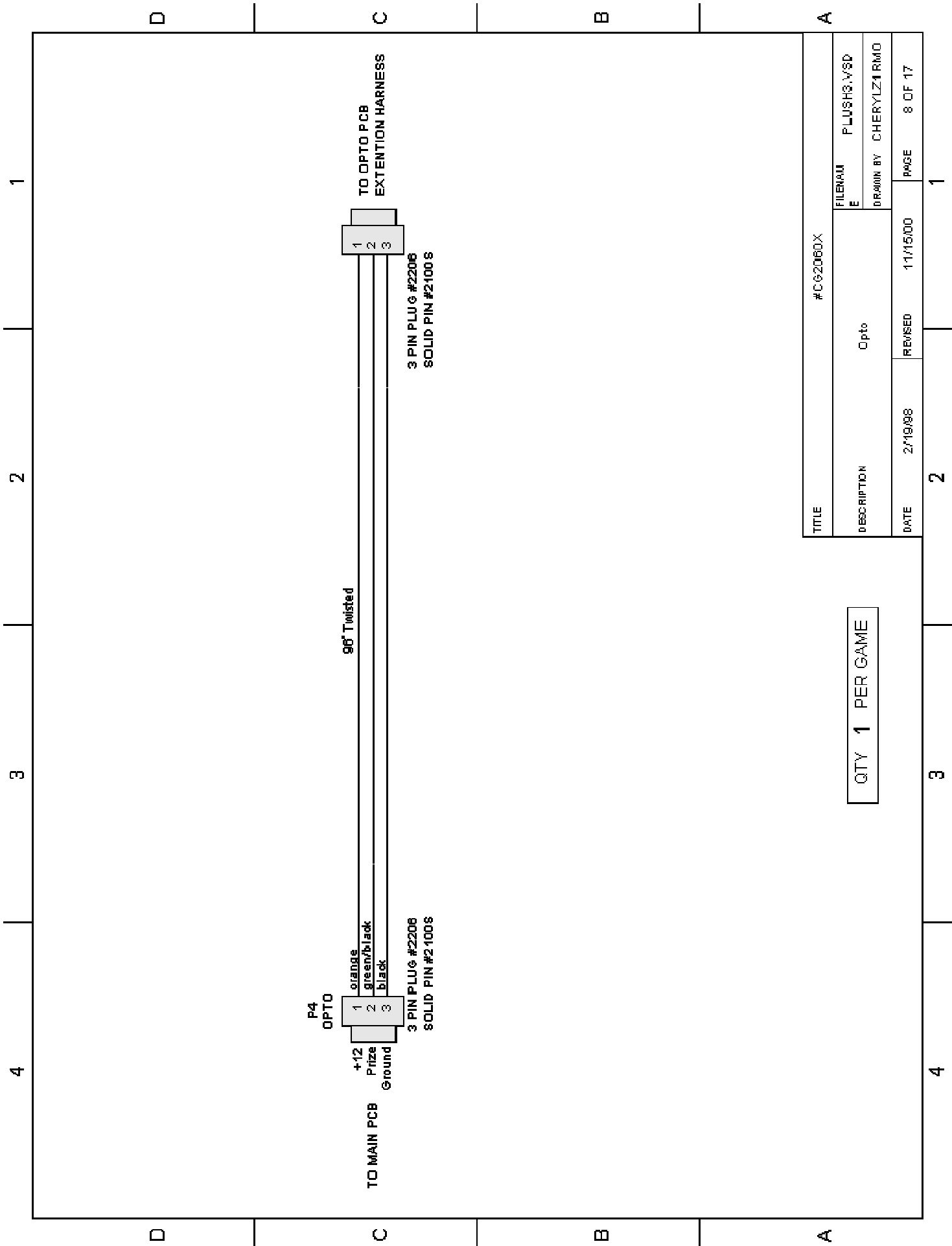

QTY 1 PER GAME

TITLE	#C02060X	
DESCRIPTION	Opto	FILENAM E PLUSHS.VSD
DATE	2/19/98	ORIGIN BY CHERYLZ1 RMO
REVISED	11/15/00	PAGE 8 OF 17

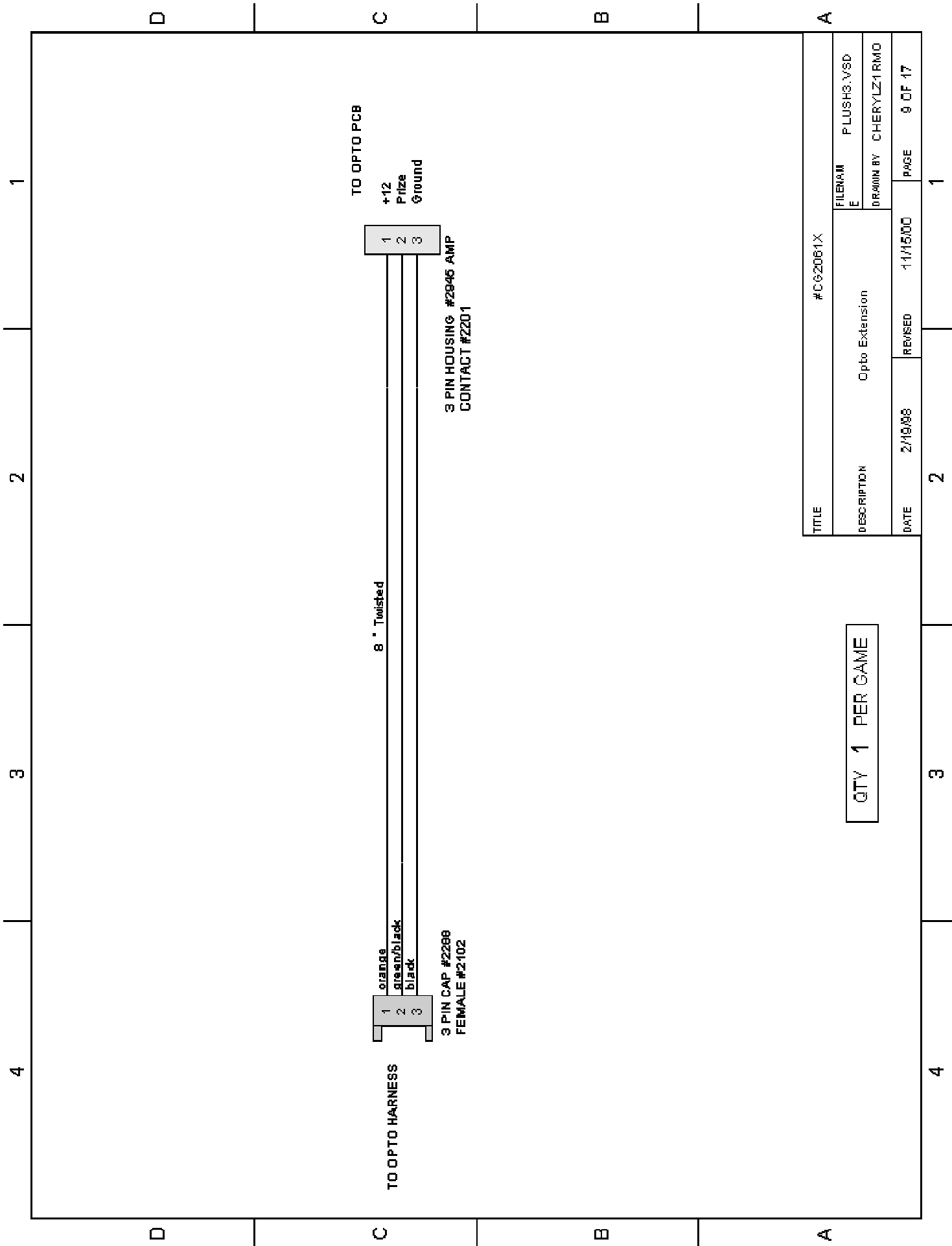

TITLE		#CG2061X	
DESCRIPTION	Opto Extension	FILENAME	PLUSHS.VSD
DATE	2/19/08	DRAWN BY	CHELYLZ1 RMO
	REVISED	11/15/00	PAGE 9 OF 17

4 3 2 1

D C B A

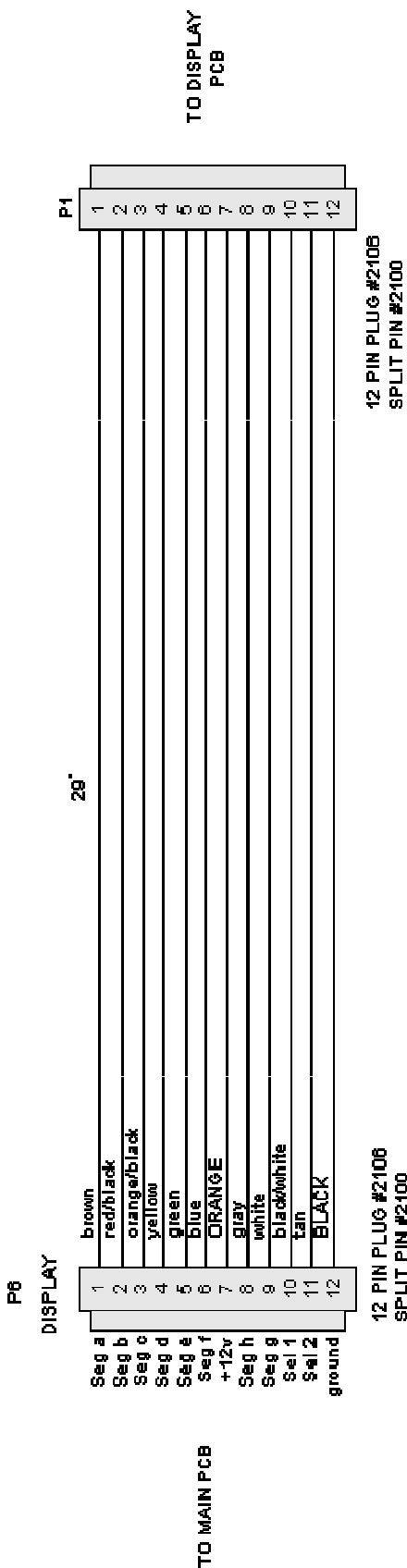

QTY 1 PER GAME

TITLE	#C62064X	
DESCRIPTION	Display	FILENAM E PLUSHS.VSD
DATE	2/18/88	ORIGIN BY CHERYLZ1RMO
REVISED	11/15/00	PAGE 10 OF 17

4 3 2 1

D C B A

1 2 3 4

D C B A

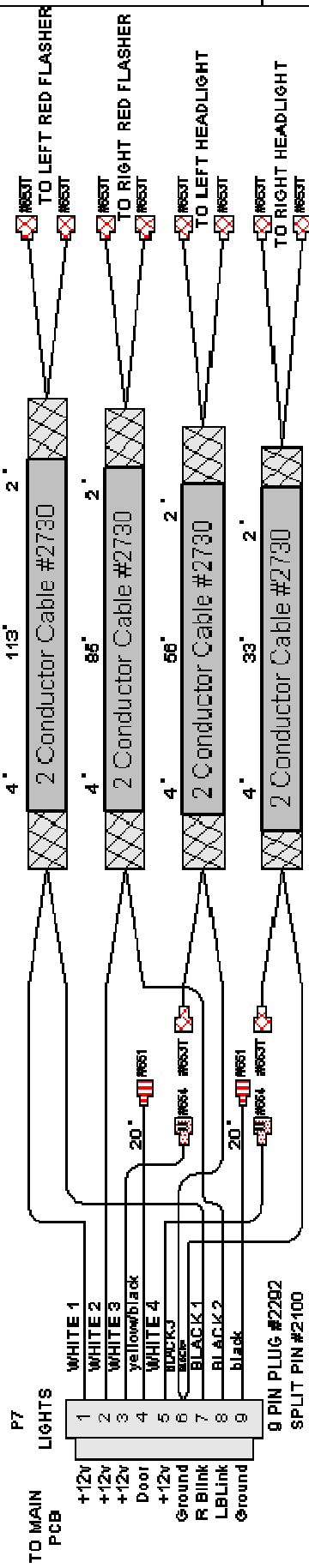

DOUBLE BLACK WIRE  
USES #2422 PIN

TITLE		#CG2058X	
DESCRIPTION	Headlight & Blinker	FILENAME	PLUS3.VSD
DATE	2/19/98	DRAWN BY	CHERYLZ1
REVISED	11/15/00	PAGE	11 OF 17

QTY 1 PER GAME

2 3 4



1  
2  
3  
4

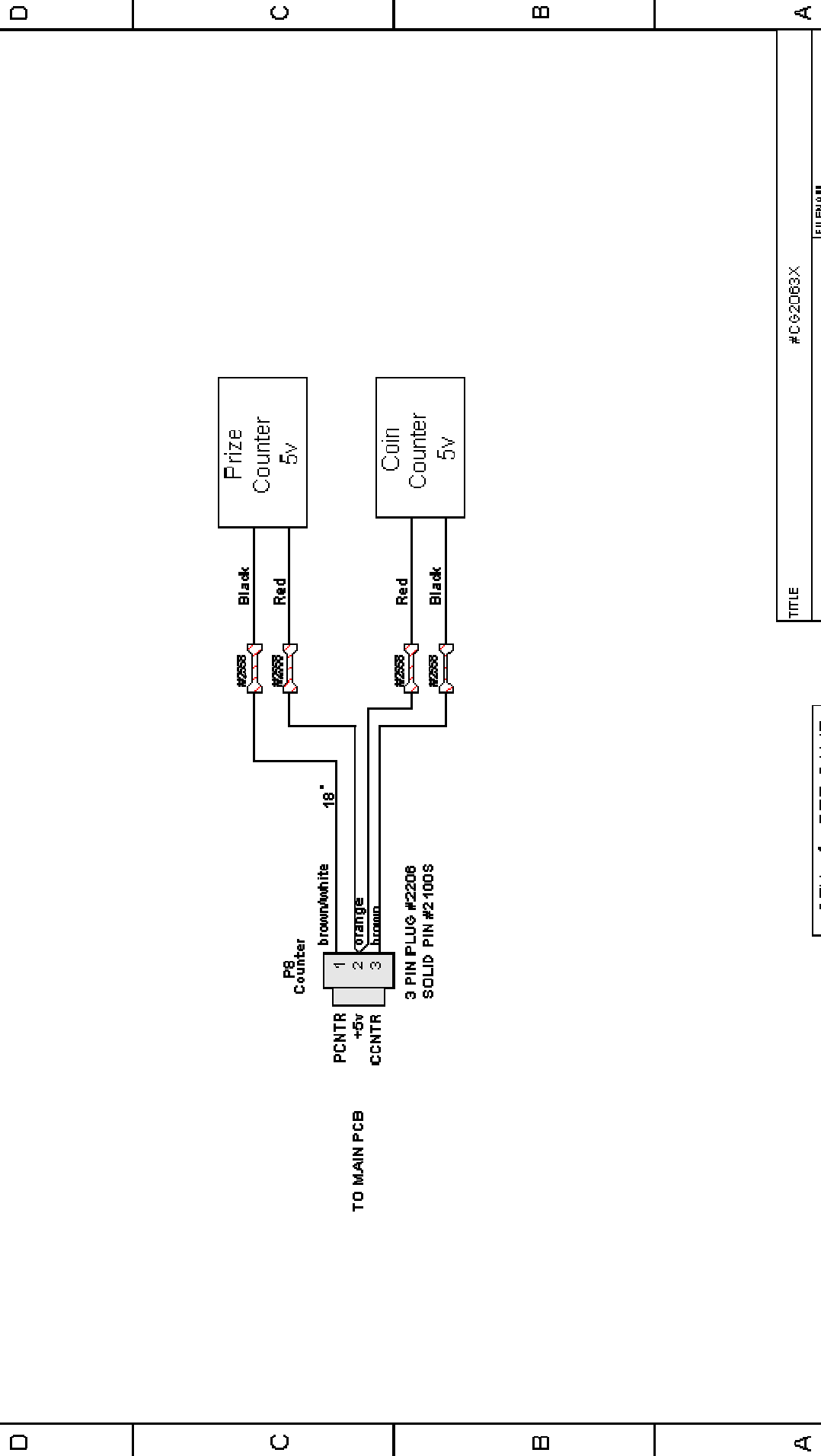

QTY 1 PER GAME

TITLE	#CG2063X	
DESCRIPTION	Counter	FILENAM PLUSH3.VSD
DATE	2/19/08	DRAWN BY CHERYLZ1RMO
REVISED	11/15/00	PAGE 12 OF 17

1  
2  
3  
4

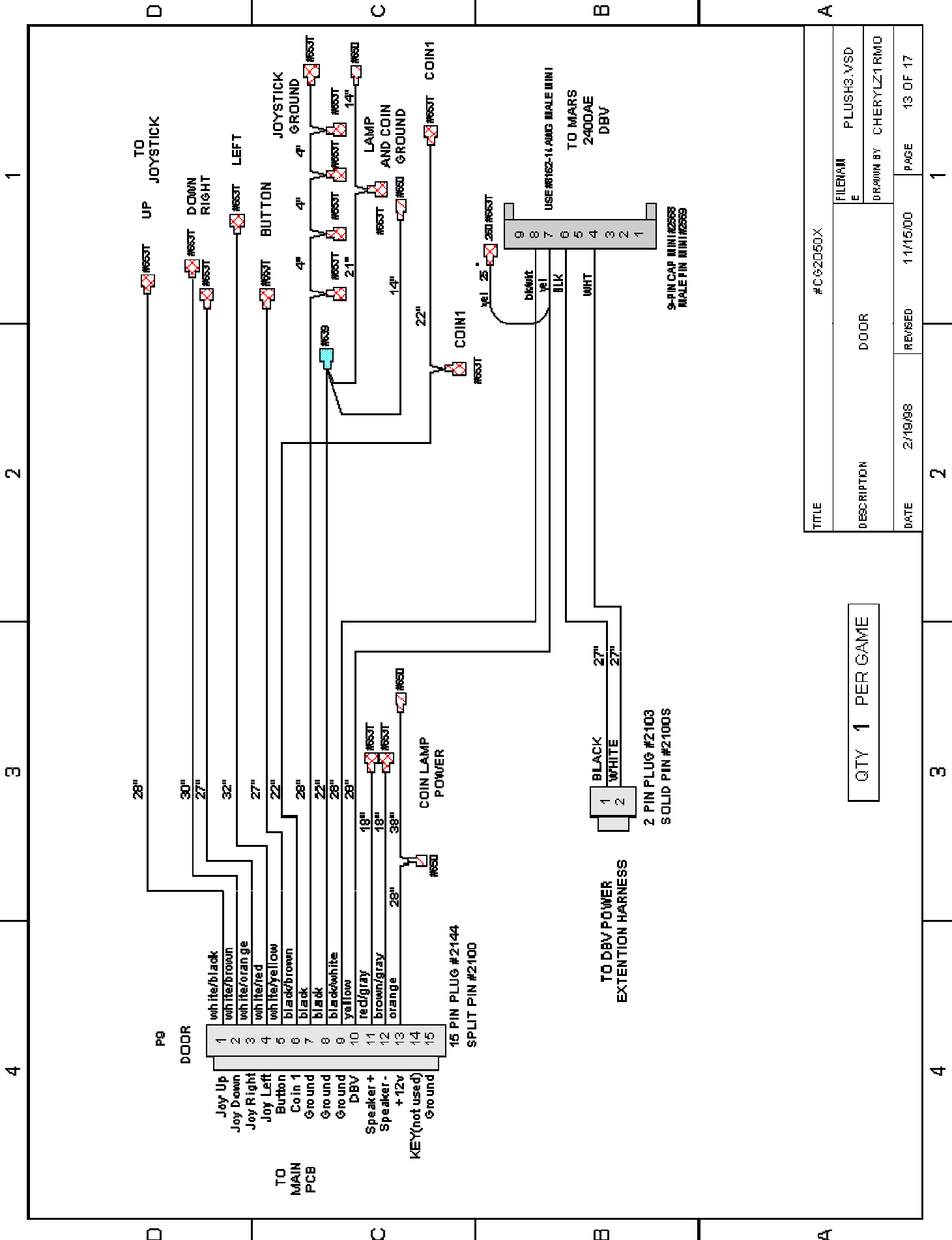

TITLE	#CG2050X	
DESCRIPTION	DOOR	FILENAME PLUS3.VSD
DATE	2/19/98	DRAWN BY CHERYLZ1RMD
REVISED	11/15/00	PAGE 13 OF 17

QTY 1 PER GAME

1 2 3 4

**TRANSFORMER #CG2002**  
**120v PRIMARY MC# 2-51-9813**

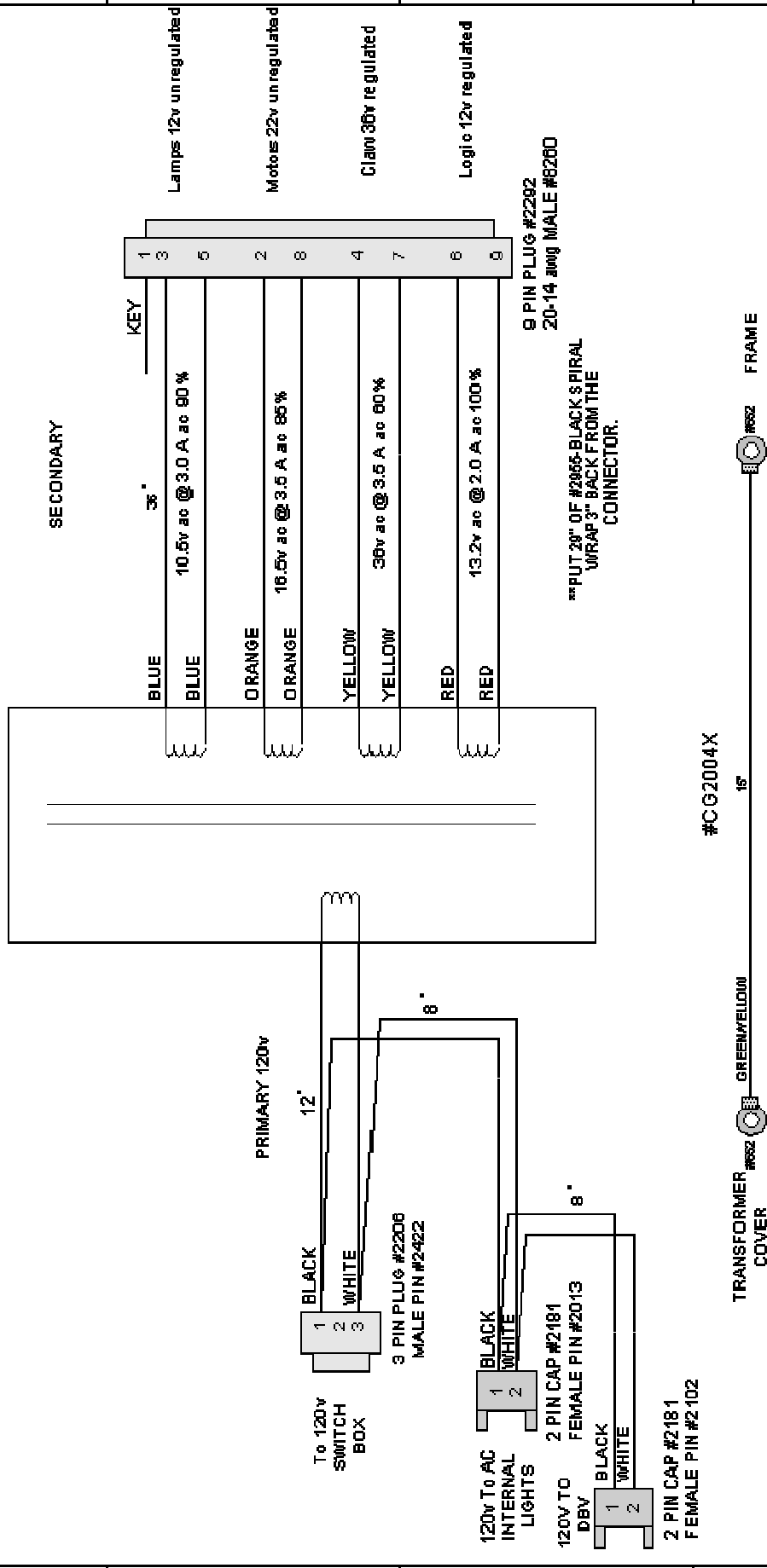

TITLE		#CG2002 XCG2004X	
DESCRIPTION	110v Transformer	FILENAME	PLUSH3.VSD
DATE	2/19/98	DRAWN BY	CHEERYLZ1RMD
REVISED	11/15/00	PAGE	14 OF 17

1 2 3 4

1  
2  
3  
4

D C B A

#CG2055X-Power Box Harness

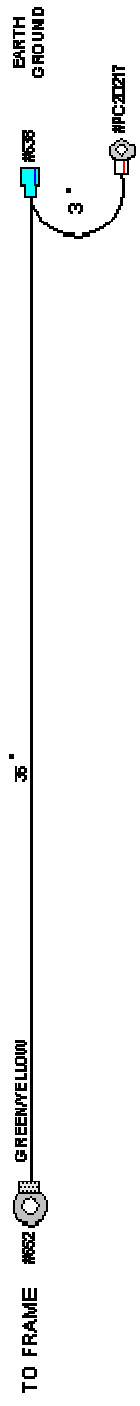
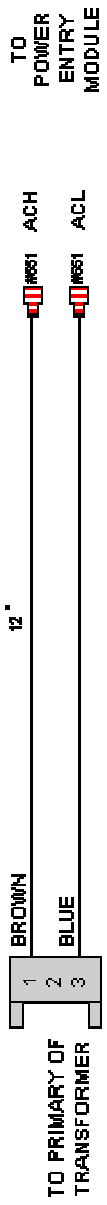

#CG2055X-DBV Power Extension

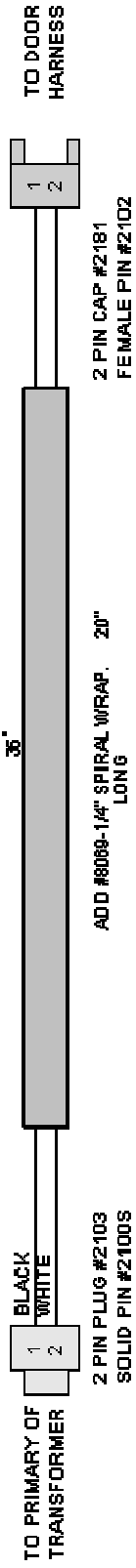

TITLE	#CG2055X & #CG2056X	
DESCRIPTION	Power Box Harness DBV Power Extension	FILENAM E PLUSH3.VSD DRAWN BY CHERYLZ1 RMD
DATE	2/19/98	REVISION 11/15/00
		PAGE 15 OF 17

4  
3  
2  
1

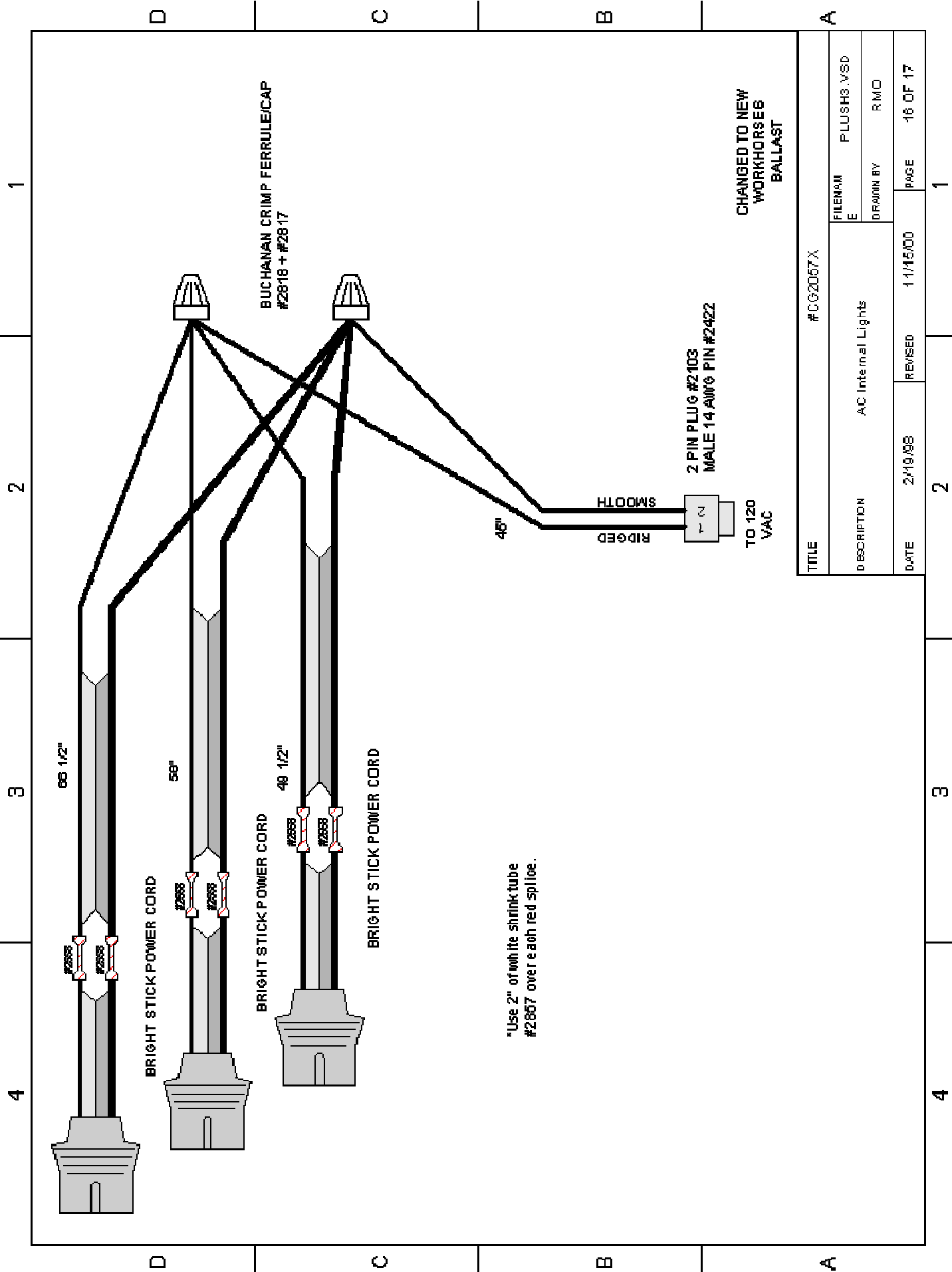

# Warranty

I.C.E warrants all components in the **PLUSH BUS™** game to be free of defects in materials and workmanship for a period of ninety days from the date of purchase.

This warranty does not cover items damaged due to normal wear and tear, subjected to abuse, improperly assembled by the end user, modified, repaired, or operated in a fashion other than that described in the service manual.

If your **PLUSH BUS™** game fails to conform to the above-mentioned warranty, I.C.E.'s sole responsibility shall be at its option to repair or replace any defective component with a new or remanufactured component of equal to or greater O.E.M. specification.

I.C.E. will assume no liability whatsoever, for costs associated with labor to replace defective parts, or travel time associated therein.

I.C.E.'s obligation will be to ship free of charge, replacement parts by U.P.S. Ground, U.S. mail, or other comparable shipping means. Any express mail or overnight shipping expense is at the cost of the purchaser.

Products will be covered under warranty only when:

- The serial number of the game with the defective parts is given.
- The serial number of the defective part, if applicable, is given.
- Defective parts are returned to I.C.E., shipping pre-paid, in a timely fashion, if requested by I.C.E.
- A copy of the sales receipt is available as proof of purchase upon request of I.C.E.

I.C.E. distributors are independent, privately owned and operated. In their judgment, they may sell parts or accessories other than those manufactured by I.C.E. We cannot be responsible for the quality, suitability, or safety of any non-I.C.E. part, or any modification, including labor, which is performed by such a distributor.



# WARRANTY

ICE Inc warrants that all of its products will be free from defects in material and workmanship.

When placing a warranty request, please be prepared to provide the following information:

- Serial Number of Game or Bill of Sale
- Machine Type
- A Detailed Description of the Equipment Fault Symptoms

ICE product, including Cromptons, Sam's Billiards, Uniana and Bell Fruit is warranted as follows:

- 180 days on the Main PCB and Computers
- 90 days on all other components (i.e. DBV's, Ticket Dispensers, etc)
- 30 days on repaired items
- 3 years on all Crane Harnessing
- 9 Months on Printers

ICE Inc shall not be obligated to furnish a warranty request under the following conditions:

- Equipment has been subjected to unwarranted stress through abuse or neglect
- Equipment has been damaged as a result of arbitrary repair/modification attempts
- Equipment that has failed through normal wear and tear

ICE Inc will assume no liability whatsoever for costs associated with labor to replace defective parts or travel time associated therein.

All defective warranty covered components will be replaced with new or factory refurbished components equal to OEM specifications. ICE Inc will cover all UPS ground, or comparable shipping means, freight costs during the warranty period. Expedited shipments are available for an additional charge.

Defective parts are returned to ICE Inc, at the customer's expense, in a timely fashion.

ICE distributors are independent, privately owned and operated. In their judgment, they may sell parts and/or accessories other than those manufactured by ICE Inc. We cannot be responsible for the quality, suitability or safety of any non-ICE part, modification (including labor) that is performed by such a distributor.

I.C.E. Parts/Service Dept.  
Innovative Concepts in Entertainment  
10123 Main St.  
Clarence, NY 14031  
Phone #: (716) - 759 - 0360  
Fax #: (716) - 759 - 0884