

THE PARTY MACHINE

ALSO AVAILABLE
WITH NEW
SMART START
TECHNOLOGY™

FROM THE MAKERS
OF THE
ORIGINAL
CASH CUBE



Allow Us To
Make Your Next
Event Something
Special, Call Today!

Great for birthday
parties/promotions!

Rugged Powder
Coated Steel Frame!

Colorful and
Festive Graphics!

New Blower Design
Blows 250 Bills!

Portable and
Programmable!

Call us for
details!

FUN
INDUSTRIES INC.

627 15th Ave.
East Moline, IL 61244
Toll-free 1-800-747-1144
Local 309-755-5021
Fax 309-755-1684

FUN INDUSTRIES INC. TRAVELER MONEY MACHINE

IMPORTANT: PLEASE READ BEFORE OPERATING THIS MACHINE



1. After removing your machine from its shipping carton and pallet, open the main door of the machine and remove the contents inside of the unit for inspection. These contents should include the accessories pouch (remote control, goggles, fabric sheets, “Stock-it-Pocket” and instructions), optional vinyl cover and rotating beacon. After inspecting the accessories, place them back inside the unit for later use.



accessories

2. Now tip the machine over on all four wheels (**assistance may be required**). You are now ready to move the unit to its event location. **We recommend using an assistant when loading or unloading the machine from its transportation vehicle.** Once at the event location, install the red beacon (if equipped) to the lid of the machine. You will find pre-wired terminals to connect and velcro to hold the beacon in place.



mount beacon

3. Stand the unit upright and plug in the main power cord located at the rear of the unit. Make sure to use a power source rated for a minimum of 15 amps. ***NOTE: EXTENSION CORDS ARE NOT RECOMMENDED!**

4. You will now need to crumple your money or coupons similar to the illustration pictured at the right. The machine will not circulate the bills properly if they are left flat or rolled up too tight. While crumpling the bills, throw them into the machine on the floor through the main door. After you have filled your machine with **up to 150 pieces**, insert one fabric sheet into the machine as well. This reduces the amount of static build-up in the machine, which can be harmful to the electronics and cause your programming to falter. Simply pull the fabric sheet out before a contestant enters the machine.

correct
→



ALWAYS USE A FRESH FABRIC SHEET WHILE DISPLAYING YOUR MACHINE

5. Now step to the rear of the machine and turn the main power switch on. Unlock the control panel door to check that the program settings are what you desire. To program the machine, push the small program button inside the control panel. Every press of this button will advance you through each of the program options. The option number is displayed on the top two digits of the display and the setting is displayed on the bottom four digits. To change the setting of any particular option, press the yellow start button located on the outside of the panel near the power switch. After advancing past the last program option, the machine will go back to regular operating mode. The program options are explained below and a quick reference chart is located on the inside rear control box door. Notice the auto/manual switch located in the control box as well. This switch changes your machines operation from manual mode to automatic mode. *Manual mode* is what you would normally run when contestants are being placed inside the machine. *Automatic mode* allows the machine to continually cycle on and off. This is used for displaying or promoting the machine.

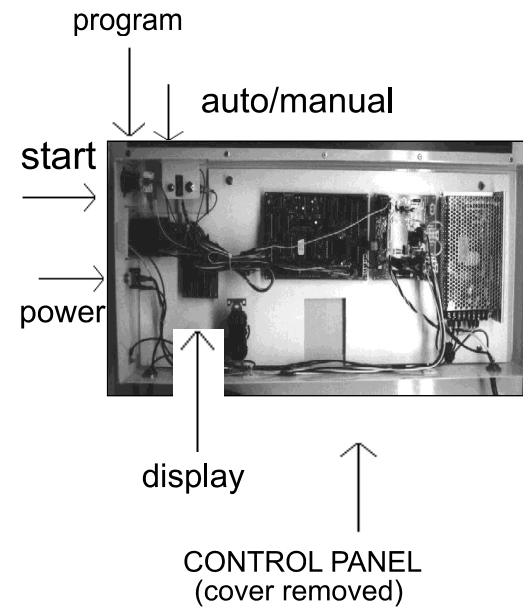

PROGRAM OPTIONS

OPTION	DESCRIPTION	FACTORY SETTING	MAXIMUM	INCREMENTS BY
#1	Manual mode run time	15	60	1
#2	Automatic mode run time	15	60	1
#3	Automatic mode pause time	20	600	10
#4	Ropelight with blower on (1=flash, 0=steady burn)	1	1	1
#5	Ropelight with blower off (1=on, 0=off)	1	1	1
#6	Ropelight flash timer (milliseconds)	150	2000	50

6. Your machine should now be ready for operation. Before placing a contestant inside the unit, turn the auto/manual switch in the rear control panel to manual mode and get your contestant prepared to enter the machine.

***ALL CONTESTANTS NEED TO WEAR SAFETY GOGGLES OR ANOTHER FORM OF EYE PROTECTION.**

If you are using the “Stock-it-Pocket” for your event, now is a good time to hang it in the slot on the outer front wall. The “Stock-it-Pocket” helps limit the amount of bills a contestant keeps, for it is quite difficult to shove the money through the slot on the front wall. After explaining your particular rules (see rules sheet) to the contestant, open the door and place them inside the machine. Once ready, press the yellow start button on the control panel. After the blower has completed its cycle and all bills have fallen to the floor, help your contestant exit the machine and remove the “Stock-it-Pocket” from the unit. **Repeat these simple steps with each new contestant and expect your event to be a success!!!**

auto/manual



start

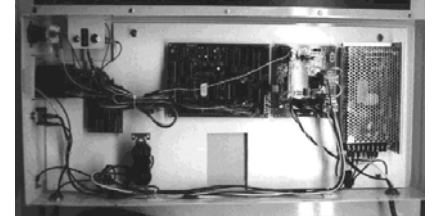

Stock-it-Pocket

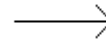

7. After your event is over, it is now time to prepare the unit for its return home. First remove all bills or coupons left over on the floor of the machine. Also if used, remove the “Stock-it-Pocket” from the front wall. Next unplug the main power cord and wrap it to the bracket on the rear of the machine. Remove the beacon (if used) and make sure that **all accessories** (see paragraph 1) are enclosed in their original package and place them on the floor of the unit. Now tip the machine over on its wheels (**assistance may be required**) and install the vinyl cover (optional). With the machine on all four wheels, move it to its transportation vehicle and have someone assist you loading the machine. Once you return home with the machine you may want to clean and prep it for your next event.

**IF YOU REQUIRE FURTHER ASSISTANCE
PLEASE CALL US AT 1-800-747-1144
Monday thru Friday, 9am to 4 pm CST**

TROUBLESHOOTING TRAVELER MONEY MACHINE

SYMPTOM

POSSIBLE SOLUTION

1. NO POWER

- A. Check that main cord is plugged in.
- B. Check that power switch is on.

2. NOT BLOWING PROPERLY

- A. Check blower cord connection to the right of the rear blower box.
- B. Check that money or coupons have been crumpled.
- C. Check that the intake on the blower is not blocked and that the vents on the ceiling and walls are open as well.
- D. Check that no more than 150 pieces are in machine.

3. FRONT DISPLAYS NOT WORKING

- A. Check the connections at the side and top of each display, they may have worked loose during transportation.

4. ERRATIC OPERATION

- A. This is usually caused by static electricity. You may have to spray the machine with “Static Guard” aerosol and reprogram your settings. Always use a fresh fabric sheet when displaying machine to reduce static buildup.

CLEANING

We recommend using a mild detergent or glass cleaner with a soft cloth for cleaning. Your machine is manufactured with an abrasion resistant coating but if not treated correctly you may damage the finish. A soft cloth is the key to cleaning your machine. Replacement panels are also available from our factory. You may also need to remove the front deflector on the floor of the machine for periodic cleaning.

IF FURTHER ASSISTANCE IS NEEDED, PLEASE CALL
1-800-747-1144 M-F 9am-4pm

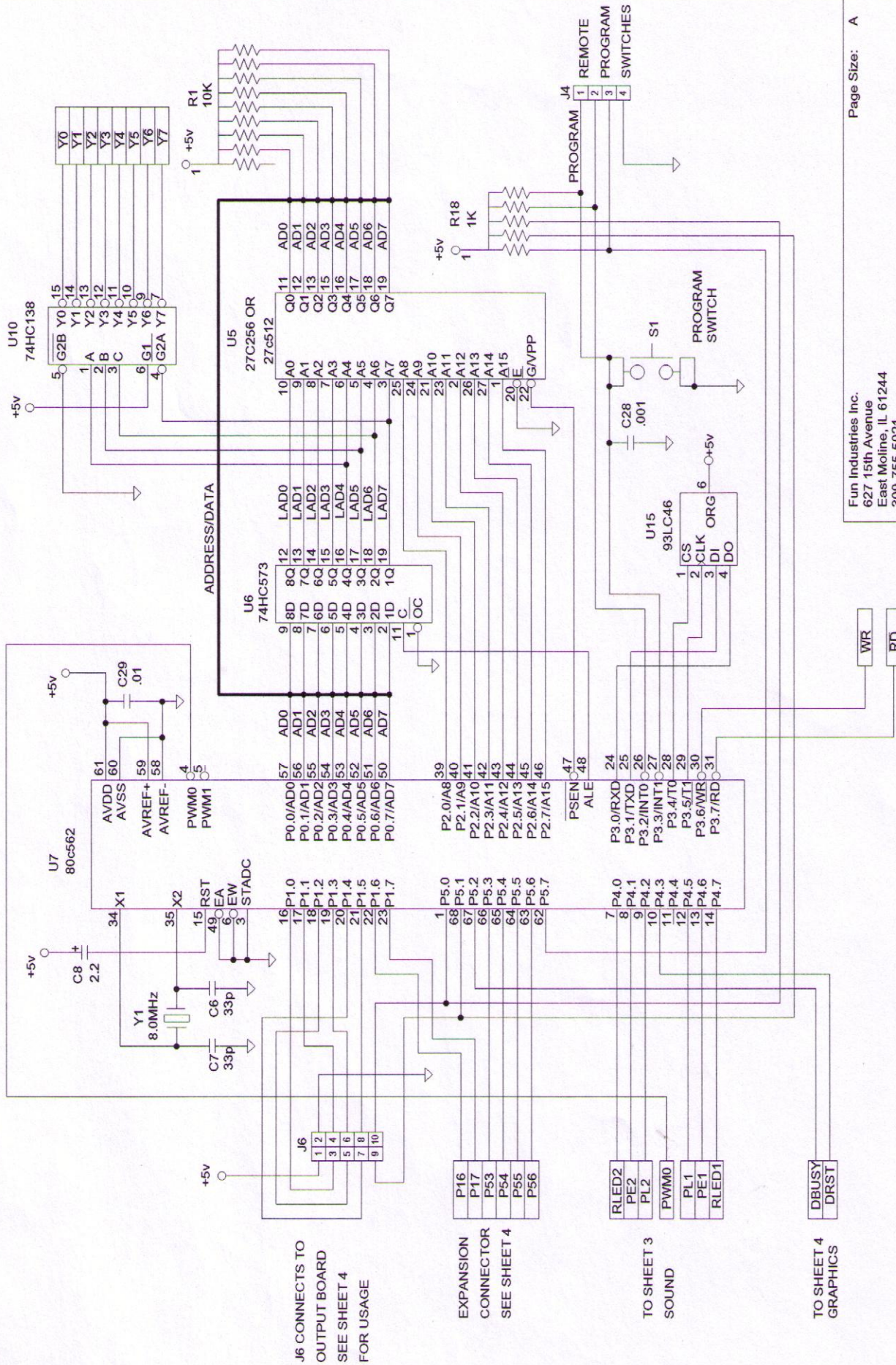

J6 CONNECTS TO
OUTPUT BOARD
SEE SHEET 4
FOR USAGE

EXPANSION
CONNECTOR
SEE SHEET 4

TO SHEET 3
SOUND

TO SHEET 4
GRAPHICS

Fun Industries Inc.
627 15th Avenue
East Moline, IL 61244
309-755-5021

SC1780 Game Board Assembly - Microprocessor Core

Revision: A

April 27, 1996

Page 1 of 4

Page Size: A

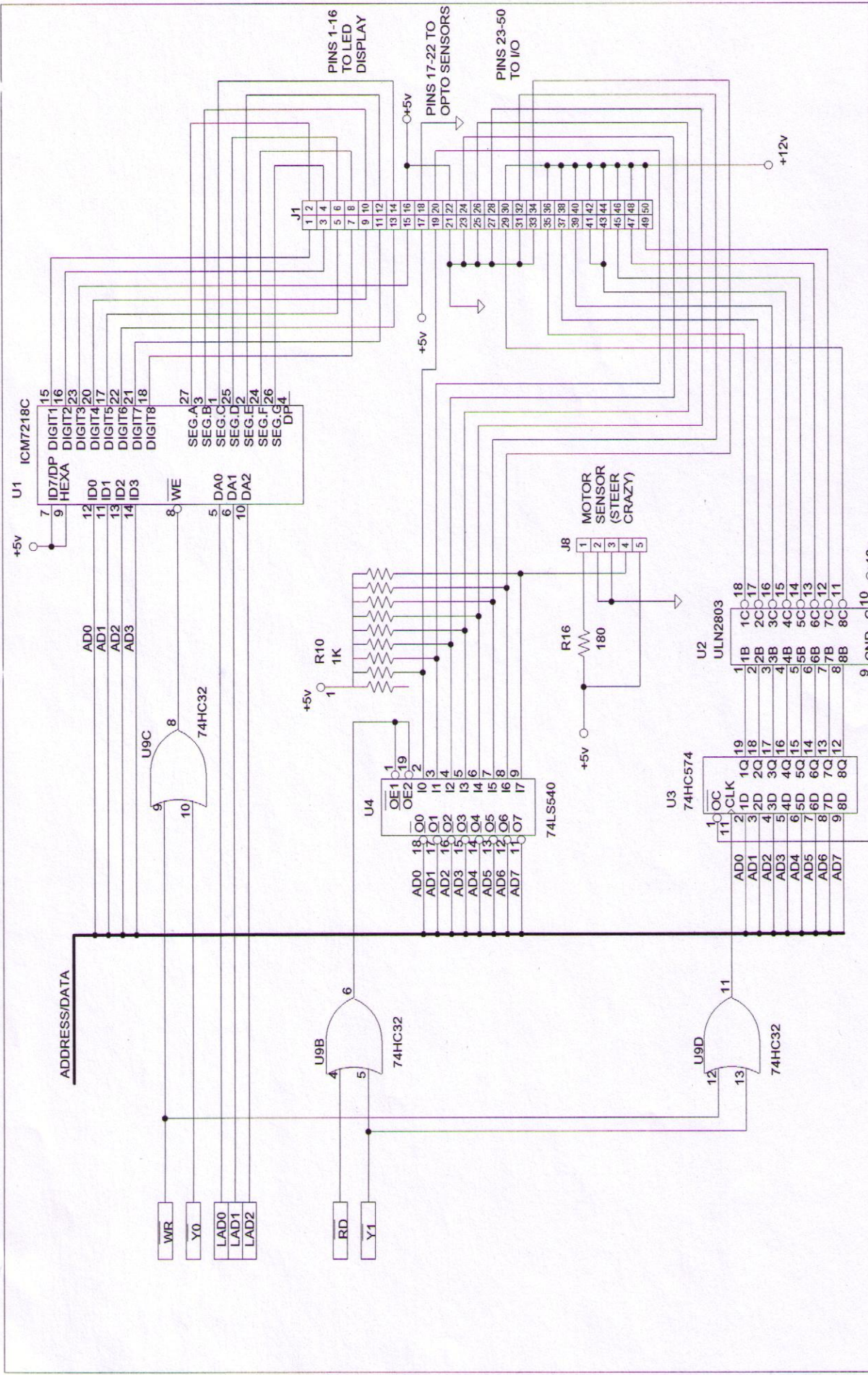

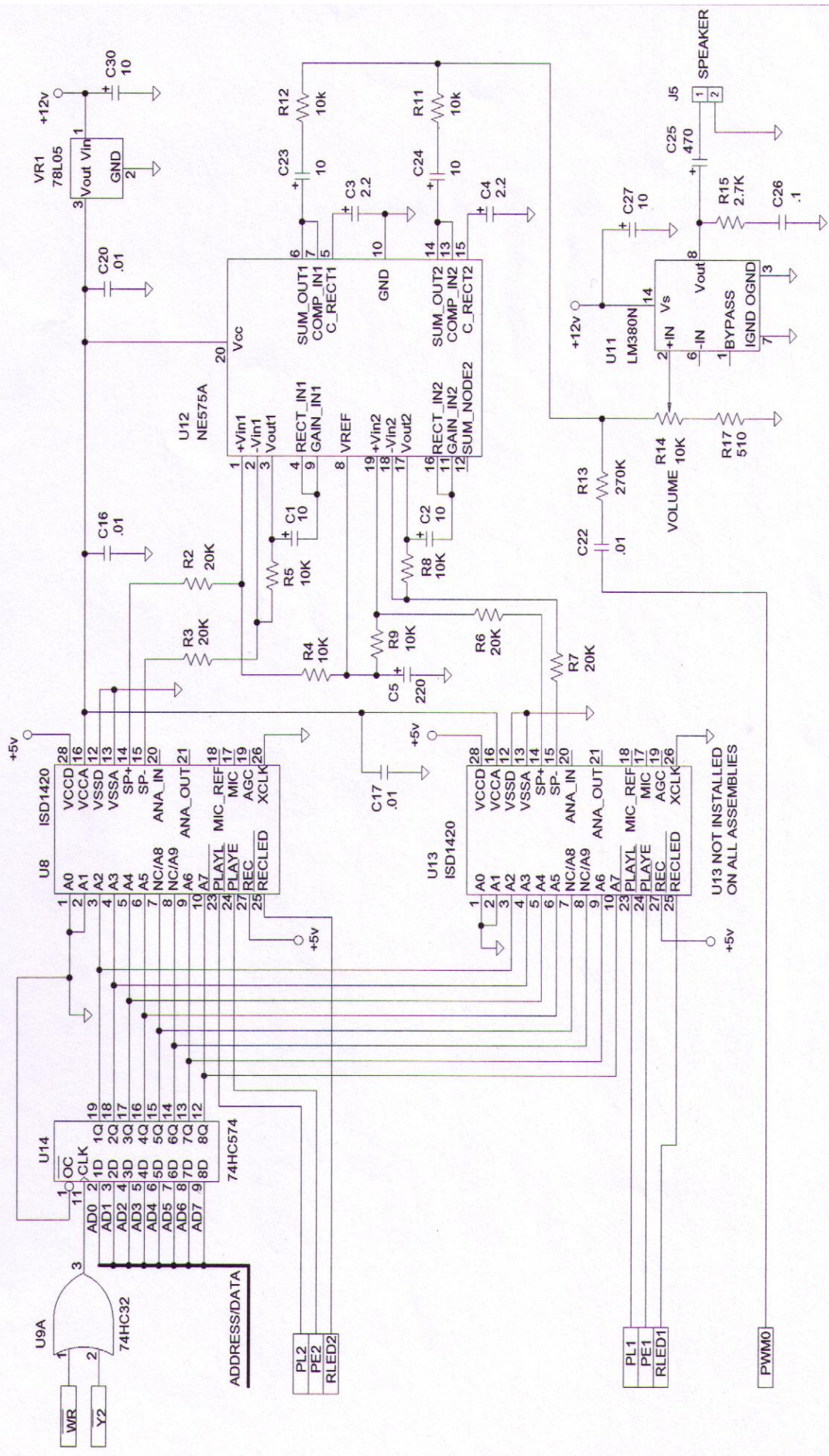

UNLESS OTHERWISE NOTED:
RESISTANCE VALUES ARE IN OHMS
CAPACITANCE VALUES ARE IN MICROFARADS

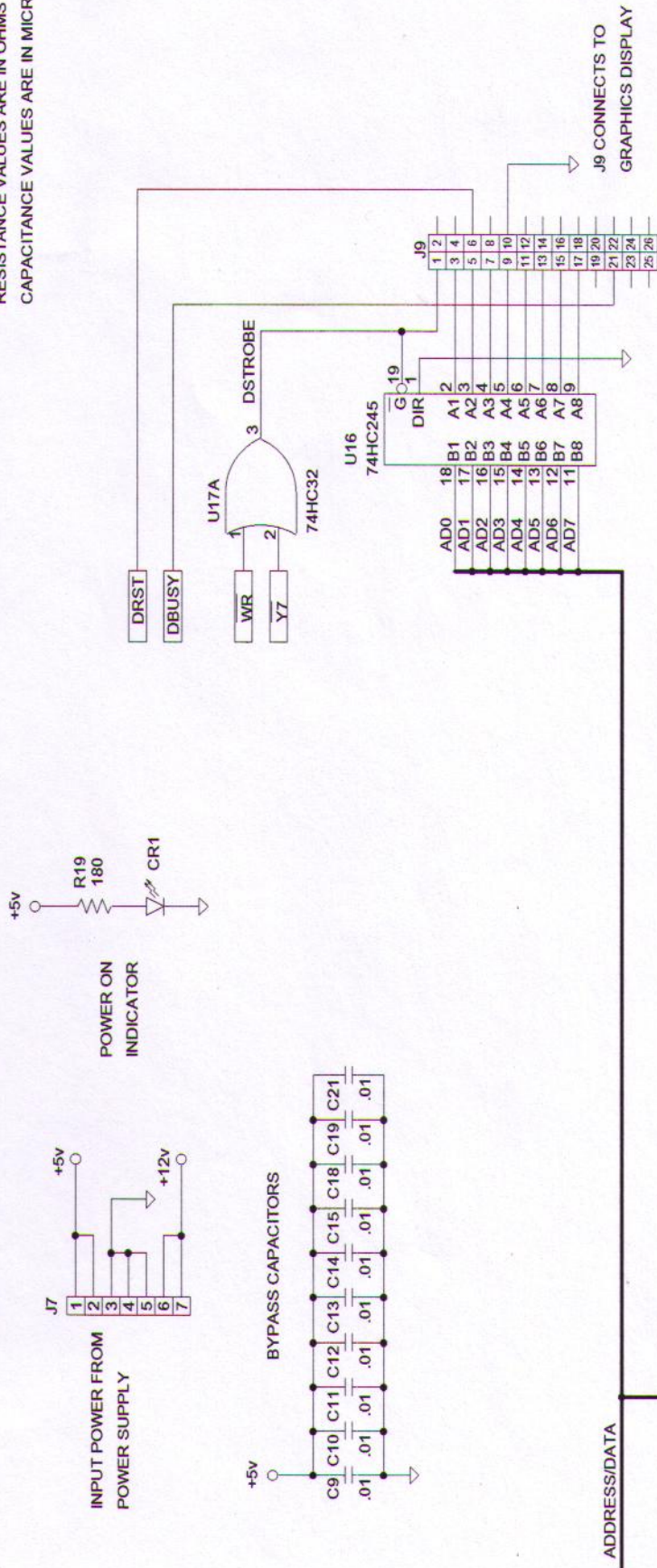

NORMAL USAGE FOR OUTPUT BOARD CONNECTOR - J6

- PIN 1 - +5 VOLTS
- PIN 2 - GND (SIGNAL COMMON)
- PIN 3 - AC OUTPUT 1 (PLAYWHEEL, VEND, OR BLOWER MOTOR)
- PIN 4 - AC OUTPUT 2 (TRAVELLER LIGHTS, SPARE, OR NOT INSTALLED)
- PIN 5 - TICKET VENDOR ENABLE
- PIN 6 - BEACON
- PIN 7 - SPARE DC OUTPUT (NOT INSTALLED)
- PIN 8 - KICKER OUTPUT (IF APPLICABLE)
- PIN 9 - TICKET NOTCH SENSOR
- PIN 10 - SPARE DC INPUT

J2 AND J3 PROVIDE CONNECTIONS TO FUTURE EXPANSION DAUGHTERBOARD

Fun Industries, Inc.
627 15th Avenue
East Moline, IL 61244
309-755-5021

SC1780 Game Board Assembly - Power, Graphics, Expansion Connector

Revision: A

April 27, 1996

Page 4 of 4

Page Size: A