



Be Sure  
to Read this  
Manual  
Before Use

# Operation Manual



Family Fun Companies, INC.



# CONTENT

Important Safety Instructions .....	2
1. SPECIFICATIONS .....	4
2. PACKAGE CONTENTS.....	5
3. PART NAMES.....	6
4. SET UP & INSTALLATION .....	8
5. HOW TO PLAY .....	12
6. GAME OPTION.....	12
7. MAINTENANCE, INSPECTION .....	19
8. OVERALL CONSTRUCTION.....	20

Thank you for purchasing **Platinum Heights**. We hope you enjoy the product.

This manual contains valuable information about how to operate and maintain your game machine properly and safely. It is intended for the owner and/or personnel in charge of product operation. Carefully read and understand the instructions.

If you need any help during installation and setup please utilize this manual and troubleshooting guide. If the product fails to function properly, *non-technical personnel should under no circumstance attempt to service the machine*. Contact your distributor or manufacturer for help.

Before use, please read **IMPORTANT SAFETY INSTRUCTIONS**.

---

## IMPORTANT SAFETY INSTRUCTIONS

**To ensure the safe usage of this product, carefully read and understand these instructions before operating your game. Save these instructions for future reference.**

Use this product only as described in this manual. Other uses not recommended may cause fire, electric shock or personal injury. Unplug the game from the outlet when not in use, when moving from one location to another, and before cleaning/servicing.

Explanations which require special attention are indicated by signs of warning. Depending on the potential hazardous degree, the terms: **NOTE**, **NOTICE**, and **WARNING** are used.

**NOTE:** A NOTE indicates useful hints or information about product usage.

**NOTICE:** A NOTICE indicates potential damage to product and how to avoid the problem.

**WARNING:** A WARNING indicates a potential for product damage or serious personal injury.

It is important to understand the meaning of the following HAZARD SIGNS before continuing:

### High Voltage and Shock Hazard:

High voltage can cause electric shock.  
Turn off/unplug power before servicing.



### High Temperature Hazard:

This part may cause scalding.  
Do not touch. Surface may be hot.



### No Touching Hazard:



This part may be hot or can cause electric shock.

Do not touch.

---

Use the following safety guidelines to help ensure your own personal safety and to help protect your equipment and surrounding environment from potential damage.

 **This product is an indoor game machine. Do not install outdoors.**

Avoid installing in the following places to prevent fire, electric shock, injury and/or machine malfunctioning:

- Places subject to rain/moisture, or places subject to high humidity.
- Places subject to direct sunlight, or places subject to extremely hot or cold temperatures to ensure that it is used within the specified operating range.
- Places where inflammable gas may be present or in the vicinity of highly inflammable/volatile chemicals or items that can easily catch fire
- On unstable or sloped surfaces. The machine may topple or cause unforeseen accidents.
- Vicinity of fire exits, fire extinguishers etc. that may block/prevent safety measures



## WARNING

Non-technical personnel who do not have technical knowledge and Expertise should refrain from performing such work that this manual require or perform tasks which are not explained in this manual. Failing to comply can cause severe accidents such as electric shock or other serious injuries.

**WARNING: To reduce the risk of fire, electric shock or personal injury, unplug or disconnect the machine from the power supply before servicing.**

Note: The contents of this manual may be updated without notice.

# 1. SPECIFICATIONS

Rated power supply: 110V 50/60Hz

Mix. Power consumption: : 66W

Max. Power consumption: 92W

Dimensions: W753.3×D1050×H2631.6 (mm)

Weight: About 147Kg

 **NOTICE:** After turning off the game, please wait at least 1 minute before restarting again.

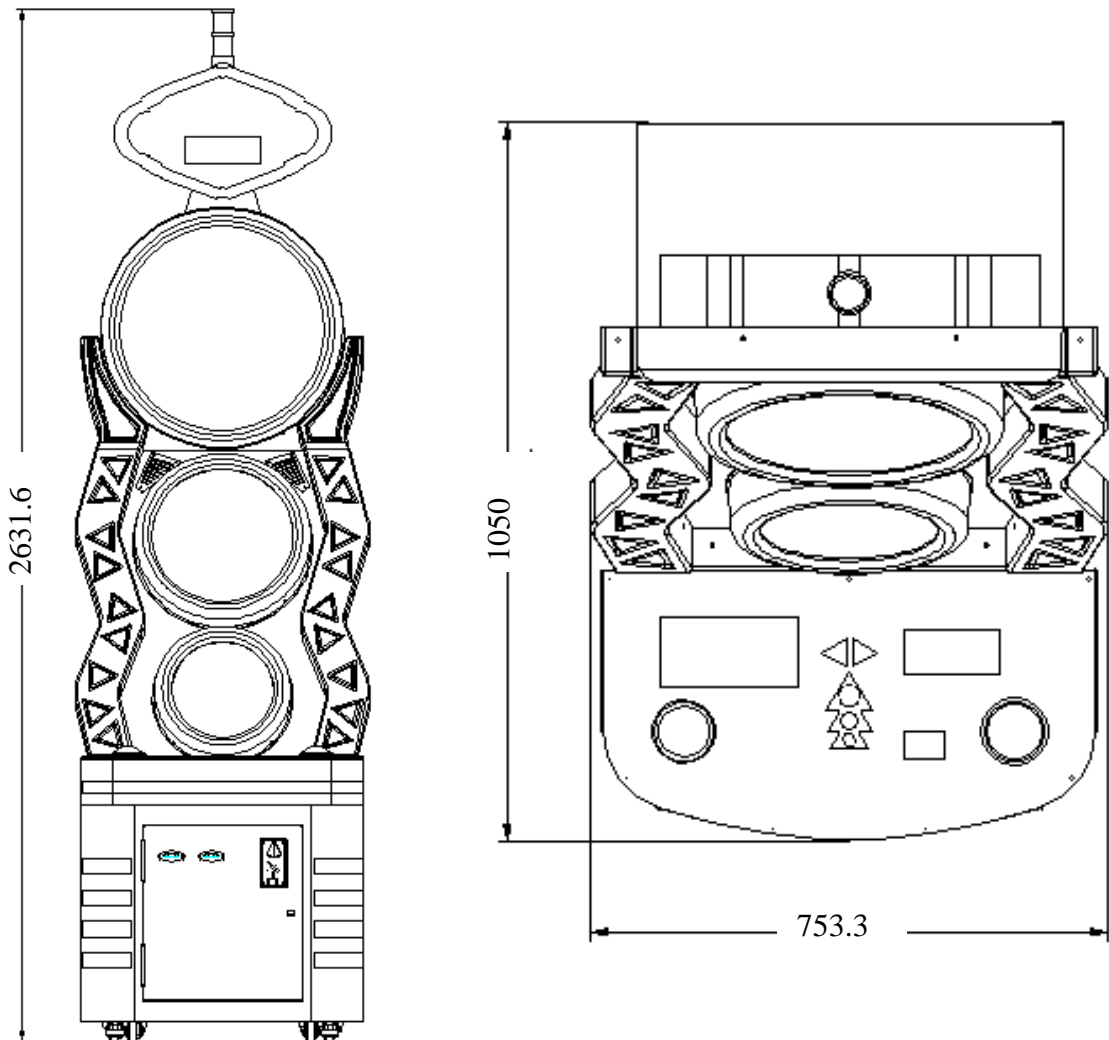





**Note:** Game parameters are subject to change without notice.

## 2. PACKAGE CONTENTS

Open the package and make sure all the items are included:

- 1 x Body Assembly
- Following accessories

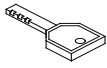
No.	Part No.	Code	Name	Spec.	Qty.	Illustration	Note
1	P110-401-000	23301000001	AC power	10A/250V 1.8m	1		
2	P110-402-000	21901000012	Fuse	Φ5×20mm T5A 250VAC	1		
3	P110-701-000	41411012002	Manual	English	1		
4	P110-403-000	25300171002	Key	171	4		
5	P110-404-000	25302222002	Key	2222	2		
6	P110-730-000	20511012009	Score decal 1		1		Top wheel
7	P110-731-000	20511012010	Score decal 2		1		Middle wheel
8	P110-732-000	20511012011	Score decal 3		1		Bottom wheel

If any items are found to be missing, please contact your sales representative for help immediately.

**NOTE:** Part models are subject to change without notice.

### 3. PART NAMES

#### FRONT VIEW

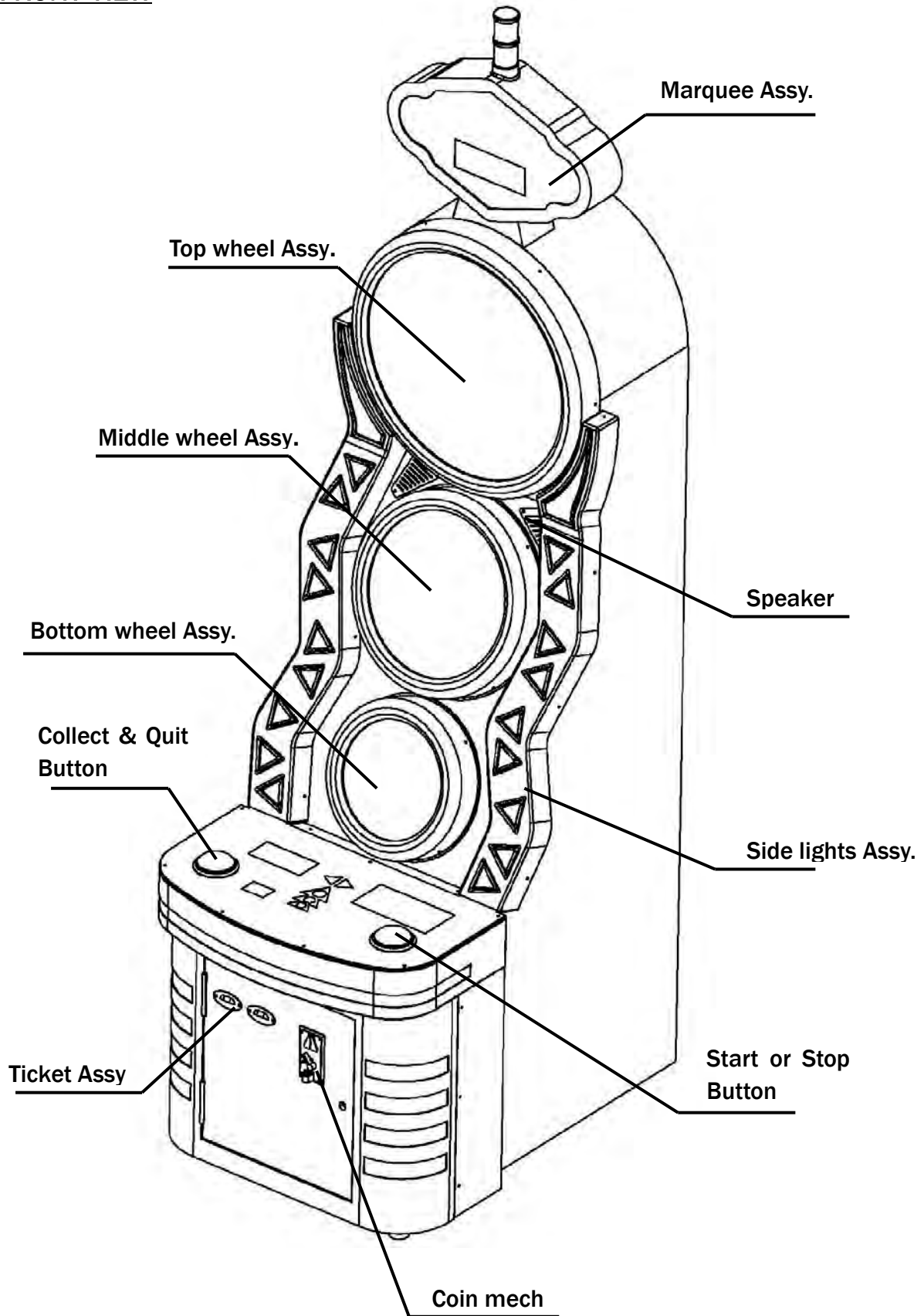

**REAR VIEW**

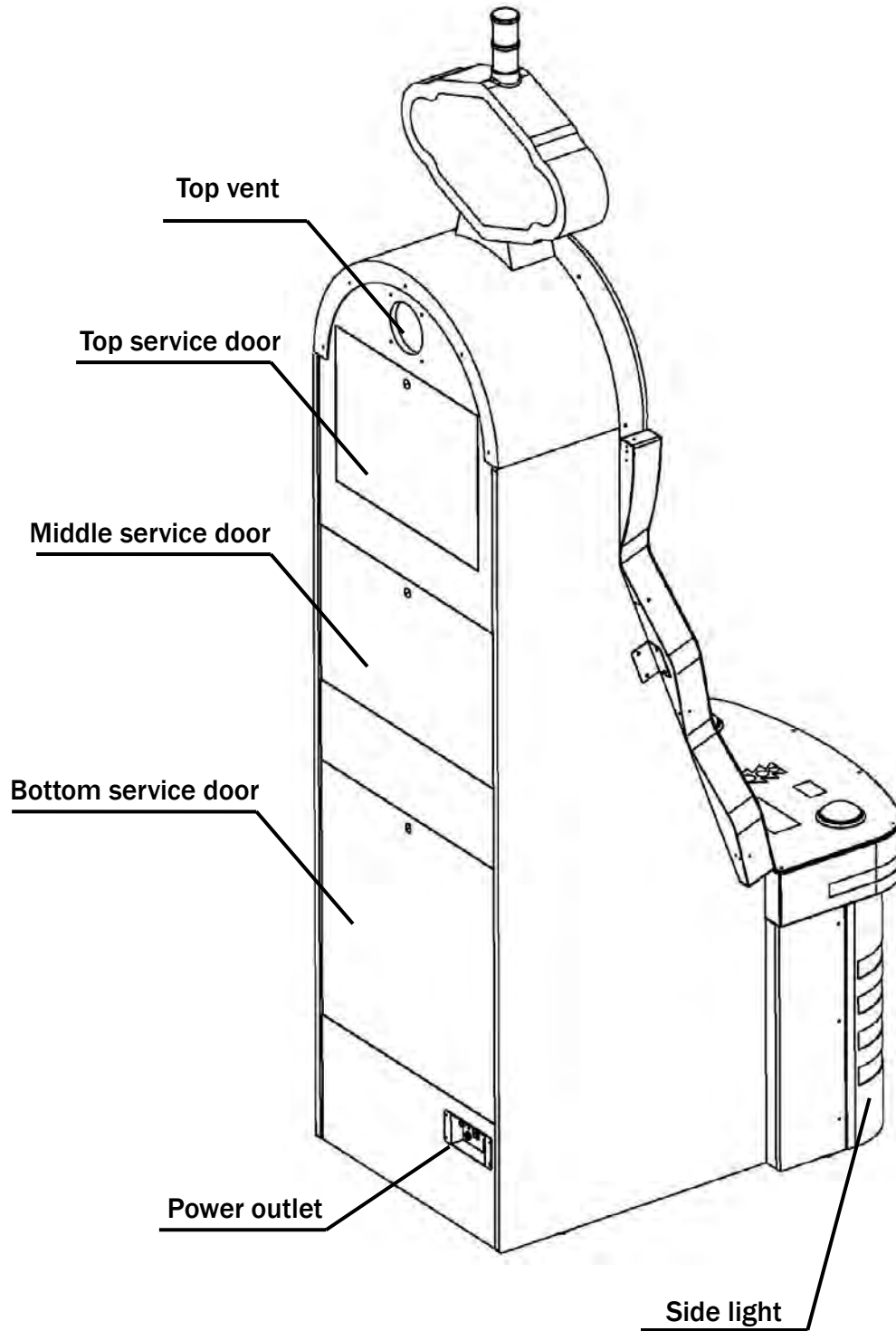



## 4. SET UP & INSTALLATION

 **This product is an indoor game machine. Do not install outdoors.**

- Refer to IMPORTANT SAFETY INSTRUCTIONS (Pg. 3) for places to avoid
- Place the unit on a dry level surface
- Ventilation openings in the back of the unit must not be obstructed by objects or by wall.

### 4.1 Play Zone

This machine requires space for playing and for maintenance as shown below.  
Leave space around the game upon installation:

**Service area: 50cm**  
**Play area: 100cm**

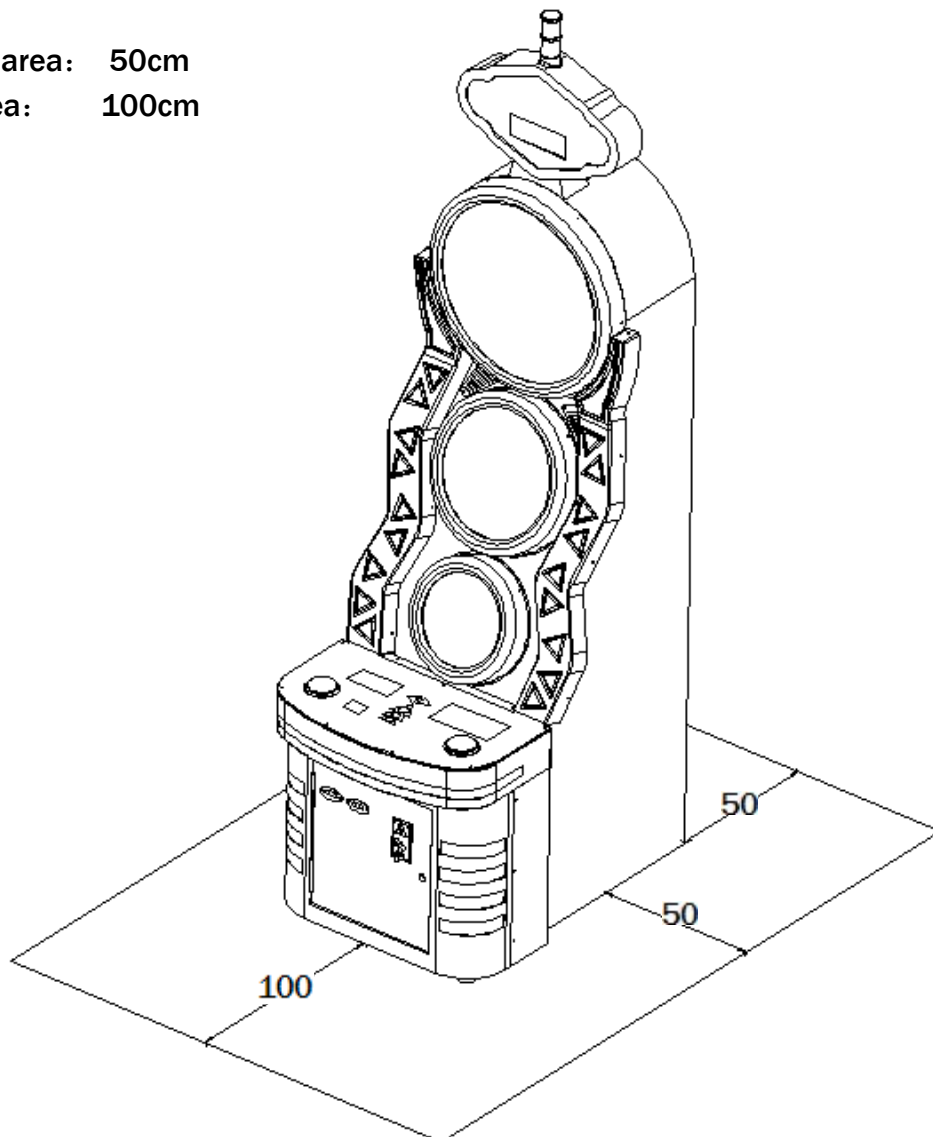

## 4.2 Level Adjustment

Install this machine on a flat surface. Adjust levers to lift casters off the ground to level the game. If the game is installed on an unsuitable floor, it could cause a malfunction.

To fix the game, adjust the Leveler down until it touches the floor, lifting the casters off the ground by 5mm. Repeat the same for all levelers.

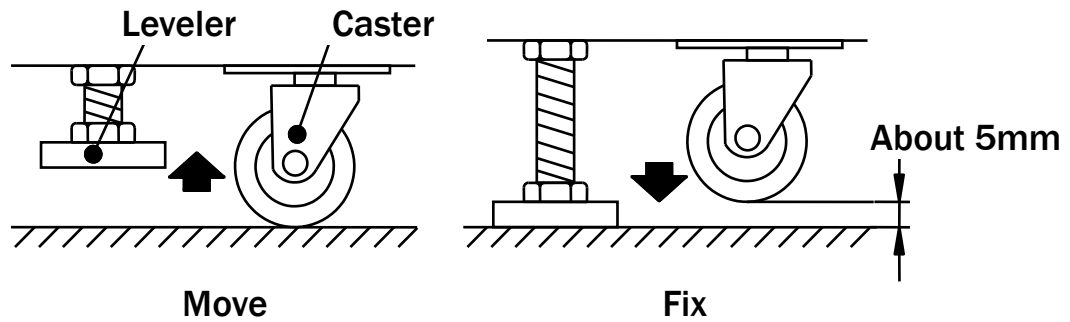

### NOTICE

Make sure the machine is level with the ground and all the adjustable legs should stick to the floor closely.

### 4.3 Transporting the Game

If you need to move the game, adjust the levelers back to an “up” position so the casters touch the ground.

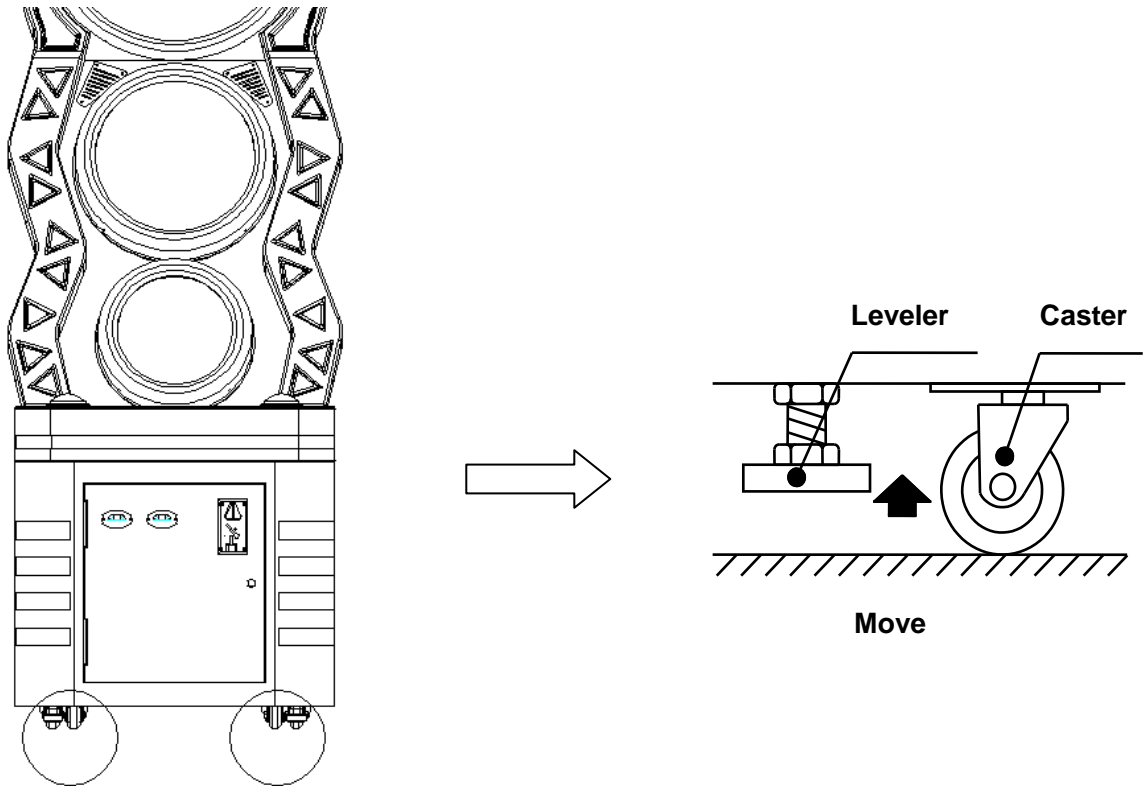

#### NOTICE

- Be careful not to damage the machine during transport.
- The machine should be handled with care when bringing it down from a higher level.
- Always unplug the game before moving.
- Keep the machine in upright position during transport.
- For longer distance transport, package the game properly to prevent damages

## 4.4 Connecting Power

**!** **WARNING:** Check the voltage rating before you connect the equipment to an electrical outlet to ensure that the required voltage and frequency match the available power source. Please refer the label of the machine.

- Do not plug the equipment power cables into an electrical outlet if the power cable is damaged.
- Avoid putting many loads on one electrical outlet as it could generate heat and fire resulting from overload.
- Connect the grounding conductor to the earth terminal (GND):

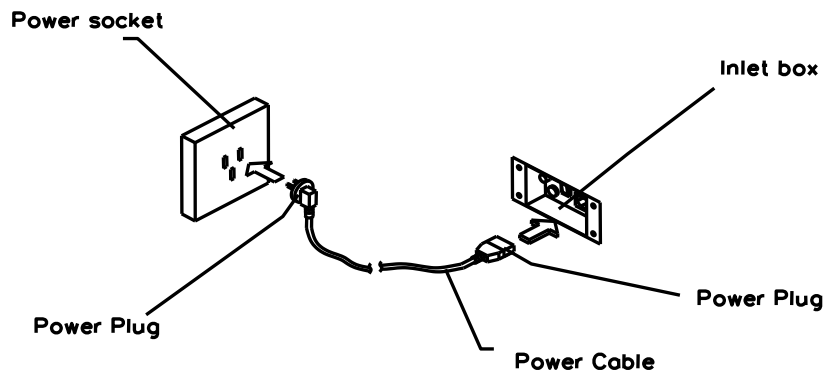

**!** **WARNING**

Ensure no heavy objects rest on the power cord. Check to make sure the game cabinet does not sit on the power cord as this could damage the cord and become hazardous.

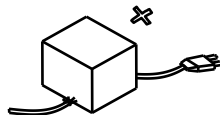

To disconnect the game, grip the plug and pull it from the wall outlet. Never pull by the cord.

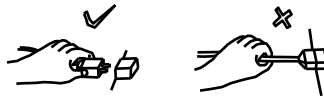

To prevent electric shock, do not touch the power plug when hand is wet.



Ensure that nothing rests on the power cord and that it is not located where it can be stepped on or tripped over.



## 5. HOW TO PLAY

- Insert coin(s);
- Press “**Start or Stop**” to spin the wheels. Hit the button again to stop the wheel to win corresponding tickets.
- If you land on “**Advance**”, you may choose to continue to the next wheel by pressing “**Start or Stop**” button; however if you are happy with the ticket amount and do not wish to continue, press “**Collect and Quit**” button to quit and collect tickets.  
(Note: tickets won in each round are not cumulative!)
- Land on “**Bonus**” to win Big.

## 6. GAME OPTIONS

### 6.1 Switches Control Signal

Refer to the I/O chart and schematics included.

To adjust DIP, refer to the I/O chart. (Initial settings are in **CAPTIAL LETTERS**.)

#### 6.1.1 Main Board

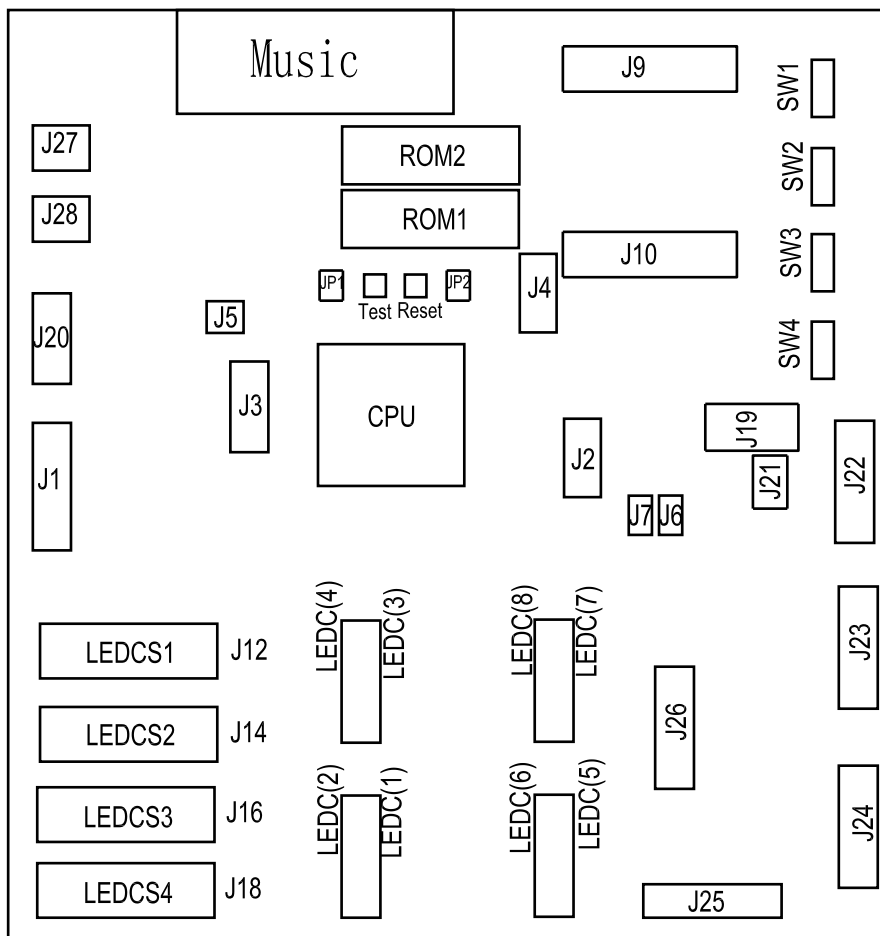

### 6.1.2 Test Method

Press the TEST button on the mainboard.

### 6.1.3 LED Display

BONUS: LED<1>1-4;      Score: LED<3>1-3;

Coin: LED<4>1-2;

Bottom wheel LED 1~12: LED<7>, LED<8>.

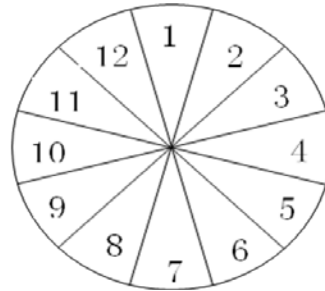

### 6.1.4 Test Method (main board)

- 1) Press Test button once: to show if all LED display is normal < 1.2.3.4.5.6.7.8.>
- 2) Press Test button again: The LED will display “111” except for one to show the state of DIP SWITCH states. There are 8 switches in a micro switch and each switch represents a segment of the LED display. If the switch is at ON, the segment will light up.
- 3) Press Test button again: The LED will display “222”. This mode will test the input signal (1-40). When you send an input signal to the main board, the corresponding input signal will show on the LED display.
- 4) Press Test button again: The LED will display “333”. No function is assigned.
- 5) Press Test button again: The LED will display “444”. It tests 40 inputs in J9, and Output J22 to J26.
- 6) Press Test button again: The LED will display “555”. It shows lighting output.

### 6.1.5 Error Codes

The following error codes will display if the input signal is not in normal state when the game is turned on (but continues to operate after the alarm sounds):

E01	Start/Stop button	E06	I6 or motor
E02	Collect ticket button	E07	I7 or motor
E03	Ticket mech reset	E83	Coin mech1
E04	Service button	E84	Coin mech2
E05	I5 or motor	HLP	No ticket or ticket mech error

## 6.2 Parameter Setting

### 6.2.1 Coin per Game

Item	Content	DIP Adjust (SW1)		Note
		1	2	
Coin(s) per game	1	ON	ON	
	2	off	on	
	3	on	off	
	4	off	off	

### 6.2.2 BONUS Initial Value

Item	Content	DIP Adjust (SW1)			Note
		3	4	5	
BONUS Initial Value	500	on	on	on	
	600	off	on	on	
	700	on	Off	on	
	800	off	off	on	
	900	on	on	off	
	1000	OFF	ON	OFF	
	1100	on	off	off	
	1200	off	off	off	

### 6.2.3 BONUS +

Item	Content	DIP Adjust (SW1)		Note
		6	7	
BONUS +	0	ON	ON	No increment
	1	off	on	Every 1 coin for 1 increment
	1/2	on	off	Every 2 coins for 1 increment
	1/3	off	off	Every 3 coins for 1 increment

### 6.2.4 BONUS Memory

Item	Content	DIP Adjust (SW1)	Note
		8	
BONUS Memory	YES	on	Keep BONUS score after restart
	NO	OFF	Reset BONUS score after restart

### 6.2.5 Ticket Payout (Ticket per Coin)

Item	Content	DIP Adjust (SW2)				Note
		1	2	3	4	
Ticket Payout (Ticket per Coin)	4	on	on	on	on	
	5	off	on	on	on	
	7	on	off	on	on	
	<b>10</b>	<b>OFF</b>	<b>OFF</b>	<b>ON</b>	<b>ON</b>	
	12	on	on	off	on	
	15	off	on	off	on	
	16	on	off	off	on	
	18	off	off	off	on	
	20	on	on	on	off	
	22	off	on	on	off	
	25	on	off	on	off	
	28	off	off	on	off	
	30	on	on	off	off	
	32	off	on	off	off	
	35	on	off	off	off	
40	off	off	off	off		

### 6.2.6 Demo Music

Item	Content	DIP Adjust (SW2)		Note
		5	6	
Demo Music	120s	on	on	
	180s	off	on	
	240s	on	off	
	<b>OFF</b>	<b>OFF</b>	<b>OFF</b>	

### 6.2.7 BONUS Max Value

Item	Content	DIP Adjust (SW2)		Note
		7	8	
BONUS Max Value	<b>1500</b>	<b>ON</b>	<b>ON</b>	
	2000	off	on	
	2500	on	off	
	3000	off	off	



### 6.2.8 Bottom Wheel Score

Item	Content	DIP Adjust (SW3)		Note
		1	2	
Bottom Wheel Score	A1	on	on	Refer to Sheet 1
	A2	off	on	Refer to Sheet 1
	A3	on	off	Refer to Sheet 1
	<b>A4</b>	<b>OFF</b>	<b>OFF</b>	Refer to Sheet 1

Sheet 1		#1	#2	#3	#4	#5	#6	#7	#8	#9	#10	#11	#12
Bottom Wheel Score	A1	20	2	10	2	12	2	15	1	18	3	12	1
	A2	30	2	15	2	18	2	20	1	25	3	15	1
	A3	40	3	25	3	18	2	25	1	35	3	15	2
	A4	50	4	35	3	20	2	5	1	40	3	15	2

### 6.2.9 Middle Wheel Score

Item	Content	DIP Adjust (SW3)		Note
		3	4	
Middle Wheel Score	B1	on	on	Refer to Sheet 2
	B2	off	on	Refer to Sheet 2
	B3	on	off	Refer to Sheet 2
	<b>B4</b>	<b>OFF</b>	<b>OFF</b>	Refer to Sheet 2

Sheet 2		#1	#2	#3	#4	#5	#6	#7	#8	#9	#10	#11	#12
Middle Wheel Score	B1	60	5	35	6	30	8	40	5	50	3	25	5
	B2	80	6	40	12	45	15	50	10	60	5	35	8
	B3	100	8	45	18	55	20	80	15	70	8	60	10
	B4	150	10	50	25	60	30	100	20	80	10	75	20

### 6.2.10 Top Wheel Score

Item	Content	DIP Adjust (SW3)		Note
		5	6	
Top Wheel Score	C1	on	on	Refer to Sheet 3
	C2	off	on	Refer to Sheet 3
	C3	on	off	Refer to Sheet 3
	<b>C4</b>	<b>OFF</b>	<b>OFF</b>	Refer to Sheet 3

Sheet 3		#1	#2	#3	#4	#5	#6	#7	#8	#9	#10	#11	#12
Top Wheel Score	C1	BONUS	15	150	20	100	16	180	10	80	25	120	18
	C2	BONUS	15	200	25	120	20	200	15	100	30	150	20
	C3	BONUS	20	250	30	150	35	250	20	120	35	180	25
	C4	BONUS	20	300	70	150	50	300	30	150	90	200	40

### 6.2.11 Pointer Speed

Item	Content	DIP Adjust (SW3)		Note
		7	8	
Pointer Speed	Slow	on		
	Fast	OFF		

### 6.2.12 Payout Method

Item	Content	DIP Adjust (SW4)		Note
		7	8	
Payout Method	1:1	ON	ON	Every 1 ticket to pay 1 ticket
	1:2	off	on	Every 2 tickets to pay 1 ticket
	1:3	on	off	Every 3 tickets to pay 1 ticket
	No Payout	off	off	No ticket payout

### 6.2.13 Input part and Output part

Output part:

OUTPUT	Content	OUTPUT	Content	OUTPUT	Content
OUT1	START/STOP button light	OUT13	Middle wheel LED5	OUT25	Top wheel LED5
OUT2	Ticket out button light	OUT14	Middle wheel LED6	OUT26	Top wheel LED6
OUT3	ARROW light 1	OUT15	Middle wheel LED7	OUT27	Top wheel LED7
OUT4	ARROW light 2	OUT16	Middle wheel LED8	OUT28	Top wheel LED8
OUT5	ARROW light 3	OUT17	Middle wheel LED9	OUT29	Top wheel LED9
OUT6	SELECT light	OUT18	Middle wheel LED10	OUT30	Top wheel LED10
OUT7		OUT19	Middle wheel LED11	OUT31	Top wheel LED11
OUT8	Advance to next wheel	OUT20	Middle wheel LED12	OUT32	Top wheel LED12
OUT9	Middle wheel LED1	OUT21	Top wheel LED1	OUT33	BottomPointerMotorPulse
OUT10	Middle wheel LED2	OUT22	Top wheel LED2	OUT34	MiddlePointerMotorPulse
OUT11	Middle wheel LED3	OUT23	Top wheel LED3	OUT35	TopPointerMotorPulse
OUT12	Middle wheel LED4	OUT24	Top wheel LED4	OUT36	Marquee BONUS light

Port	Content	Port	Content	Port	Content
J19-1	coin lock1	J21-6	Ticket mech 2 feedback	J27-2	Speaker L
J19-2	Coin SW1	J21-7	12V	J28-1	Speaker R
J19-3	GND	J21-8	GND	J28-2	Speaker R
J19-4	coin lock2	J8-1	+12V	J4-1	wheel S-I
J19-5	Coin SW2	J8-2		J4-2	wheel D-I
J19-6	12V	J8-3	ticket counter	J4-3	wheel CK-I
J21-1	Ticket mech 1 drive	J8-4	coin counter	J4-4	wheel L-I
J21-2	Ticket mech 1 feedback	J5-1	RS-485B	J4-5	console S-I
J21-3	12V	J5-2	RS-485A	J4-6	console D-I
J21-4	GND	J5-3	GND	J4-7	console CK-I
J21-5	Ticket mech 2 drive	J27-1	Speaker L	J4-8	console L-I

Input part:

INPUT	Content
I1	START/STOP button
I2	Ticket out button
I3	Ticket mech reset
I4	Service button
I5	Bottom pointer initial position
I6	Middle pointer initial position
I7	Top pointer initial position



**Notice**

The above are subject to change without notice.

## 7. MAINTENANCE, INSPECTION

### 7.1 Safety Check

Check the points listed before operating the machine. These checks are necessary for safe machine operation:

1. Try to run the game before operation each day.
2. Conduct monthly routine checks of game components to ensure good working condition
3. Check the machine regularly for dust and clean when necessary.

**Note:** Parts and components require preventative maintenance to be kept running smoothly

### 7.2 Handling Precautions

When installing or inspecting the machine, be very careful of the following points and pay attention to ensure that the player can enjoy the game safely.

Non-compliance with the following points or inappropriate handling running counter to the cautionary matters herein stated can cause personal injury or damage to the machine



#### WARNING

- Before servicing the machine, be sure to turn power off. Servicing without turning the power off can cause electric shock or short circuit.
- To avoid electric shock or short circuit, do not plug then unplug the power quickly
- Do not expose power cords and earth wires, these are susceptible to damage.
- Damaged cords and wires can cause electric shock or short circuit and should be replaced immediately.
- When or after installing the product, avoid pulling the power cord to prevent unnecessary wear and tear. Use the power button to disconnect power.
- In case the power cord is damaged, ask for replacement through where the product was purchased from or replace locally. Continued usage of damaged cord can cause fire, electric shock or leakage.
- Perform grounding appropriately. Inappropriate grounding can cause electric shock.
- Use fuses that meet specified rating. Fuses exceeding can cause an electric shock.
- Should a problem occur, turn off the power immediately and stop operating the machine. Unplug the power cord of the service outlet. Operating the machine without correcting the problem may cause a fire or injuries.
- Insert the power plug securely into the outlet. Poor contact may cause overheating, resulting in fire or burns.
- To ensure the warning labels attached on the machine are visible and legible, install the machine in a well-lit location, and keep the labels clean at all times. Make sure the labels are not hidden behind other game machines.

## 8. OVERALL CONSTRUCTION

### 8.1 Main Assembly

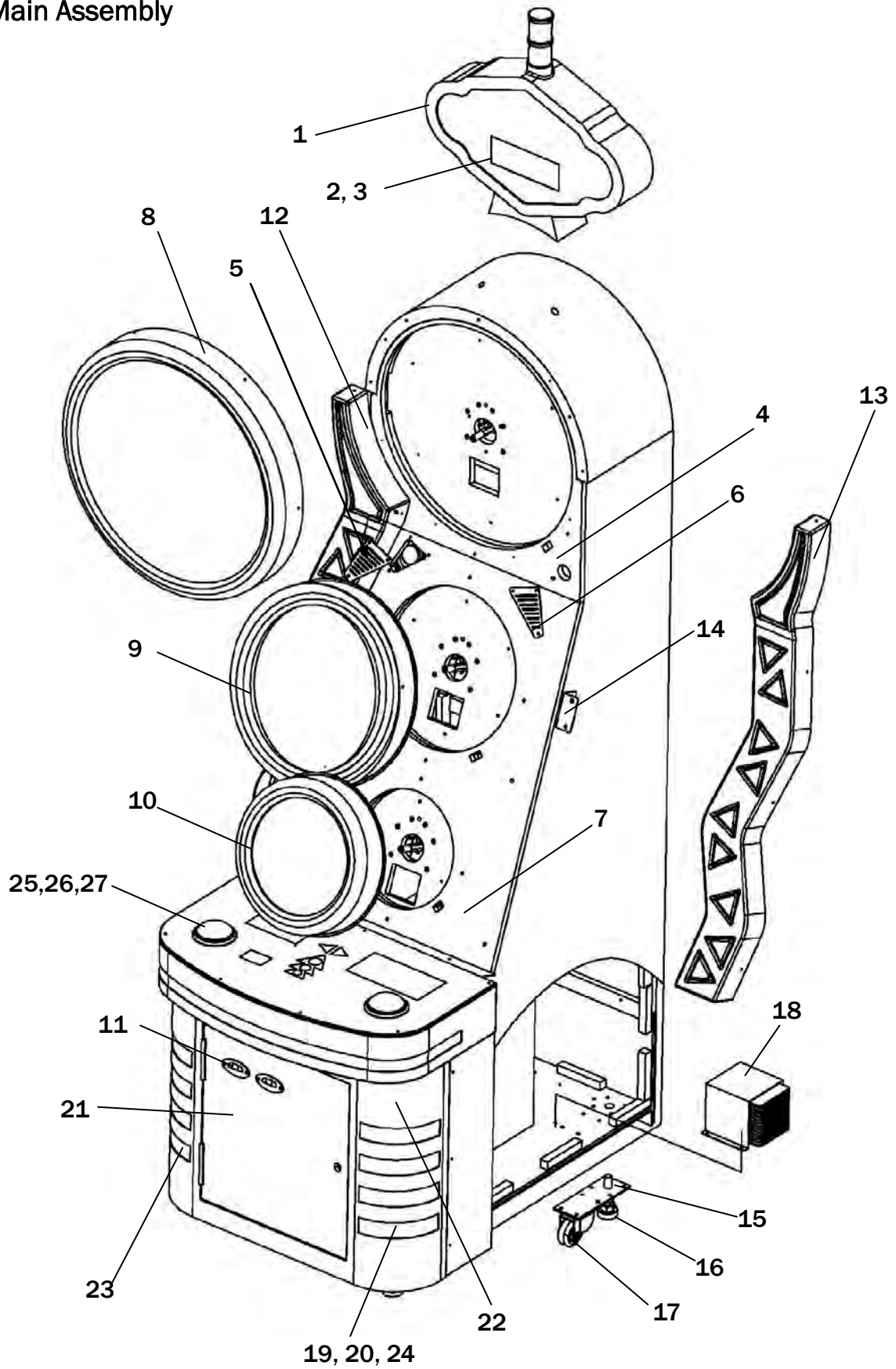

No.	Part No.	Diagram No.	Name	QTY	Spec.	Note
1	P110-100-000	22013020001	Marquee	1		
2	P110-101-000	BBGS-05-01	LED fixed plate-L	1	Metal	
3	P110-102-000	BBGS-05-02	LED fixed plate-R	1	Metal	
4	P110-600-000	BBGS-00-04	Top plate mirror	1	Plastic, δ1.2	
5	P110-104-000	BBGS-00-18	Speaker grill-L	1	Stainless steel, δ1.5	
6	P110-105-000	BBGS-00-19	Speaker grill-R	1	Stainless steel, δ1.5	
7	P110-601-000	BBGS-00-03	Bottom plate mirror	1	Stainless steel, δ1.2	
8	P110-001-000	BBGS-02-00E	Top wheel assy.	1		
9	P110-002-000	BBGS-03-00E	Middle wheel assy.	1		
10	P110-003-000	BBGS-04-00E	Bottom wheel assy.	1		
11	P110-107-000	BBGS-00-30	Ticket shield	2	Q235,black,δ1.2	
12	P110-004-000	BBGS-07-00	L-marquee assy.	1		
13	P110-005-000	BBGS-06-00	R-marquee assy.	1		
14	P110-108-000	BBGS-00-26	Marquee bracket	2	Q235black,δ1.5	
15	P110-109-000	TY-JX-010	Caster bracket	4	Q235,δ3	
16	P110-449-000	TY-JX-008	Leveler	4	Q235,M16X100	
17	P110-450-000	25501000056	Caster	4	2.5", 3-2689-52	
18	P110-405-000	22803000032	2.1 amplifier	1	RA150	
19	P110-602-000	BBGS-00-06	Light cover B	2	White plastic, δ3	
20	P110-111-000	BBGS-00-08	Light fixed plate B	2	Q235,black,δ1	
21	P110-500-000	BBGS-01-10M	Front door	1	MDF	
22	P110-112-000	BBGS-01-08	Front door frame	1	Q235,black,δ1.5	
23	P110-406-000	20740917007	Front side lamp-L	1	LED5050RGB-NC.PC B(V1.0)	
24	P110-407-000	20740917007	Front side lamp-R	1	LED5050RGB-NC.PC B(V1.0)	
25	P110-408-000	22401000004	Button	2	White Φ100	
26	P110-409-000	22003000006	LED	2	LED(12V) white, JA-T810	
27	P110-410-000	22604000006	Micro SW	2	BLM-S 3A-125/250VAC	

## 8.2 Control Panel Assembly

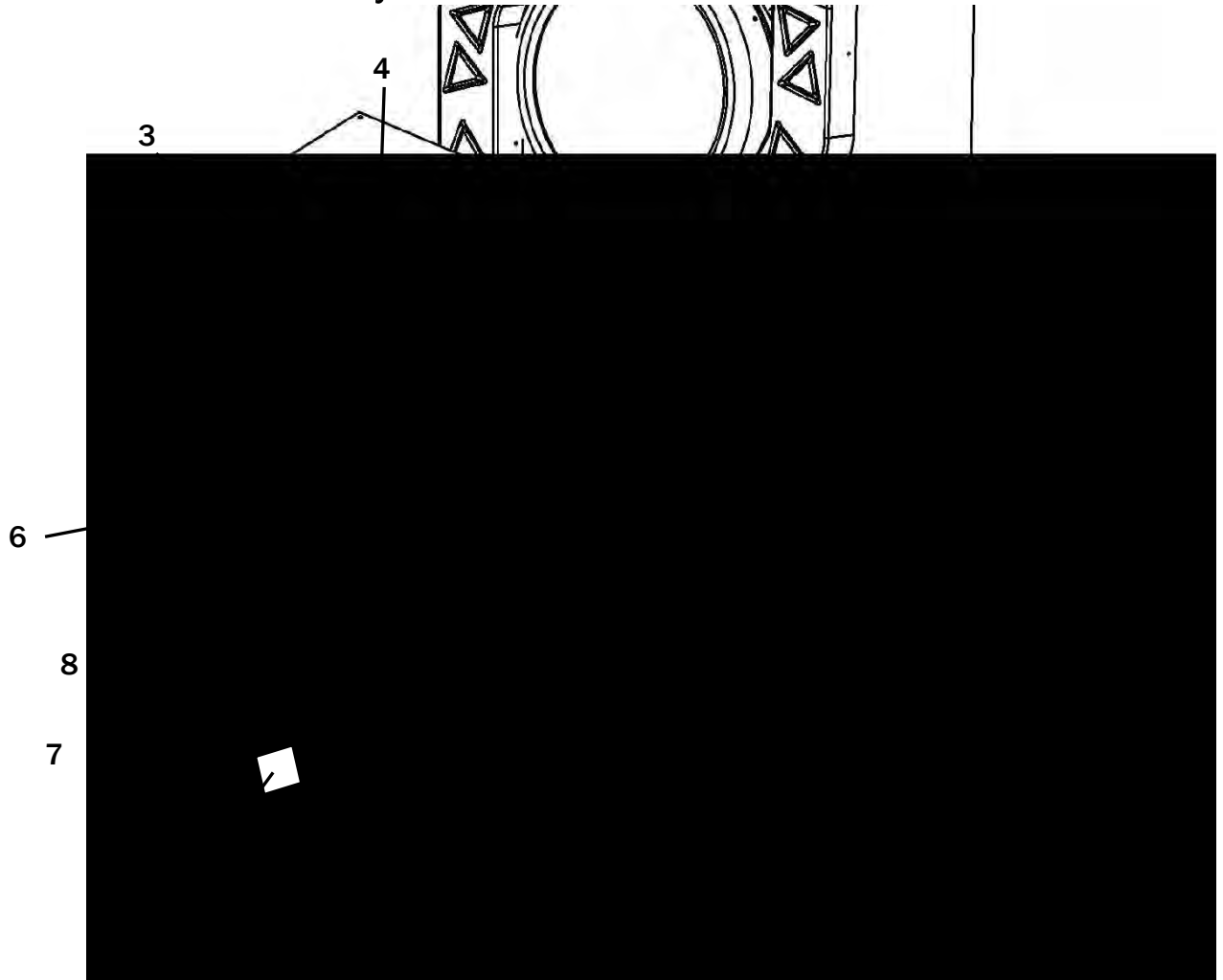

No.	Part No.	Diagram No.	Name	Qty	Spec.	Note
1	P110-451-000	BBGS-00-31	Meter bracket	1	Q235,black,δ3	
2	P110-113-000	BBGS-00-01	Control panel	1	Q235,black,δ1.5	
3	P110-501-000	BBGS-00-12M	Control panel plate	1	MDF	
4	P110-114-000	BBGS-00-10	Reinforced plate-L	1	Q235,black,δ1.5	
5	P110-115-000	BBGS-00-11	Reinforced plate-R	1	Q235,black,δ1.5	
6	P110-116-000	BBGS-00-02	Light fixed plate A	5	Q235,black,δ1	
7	P110-411-000	22301000006	Coin mech	1		
8	P110-412-000	23100000006	Ticket dispenser	2	CL-022Q-386	
9	P110-502-000	BBGS-01-14M	Coin box outer	1	MDF black	
10	P110-503-000	BBGS-01-16M	Coin box inner	1	MDF black	
11	P110-117-000	BBGS-01-17	Coin box handle	1	Q235, black,δ1.5	
12	P110-603-000	BBGS-00-05	Control panel light cover A	1	Plastic, δ3	
13	P110-413-000		Ticket inverter board	2	TICK-CH.PCB	

### 8.3 Rear Cabinet Assembly

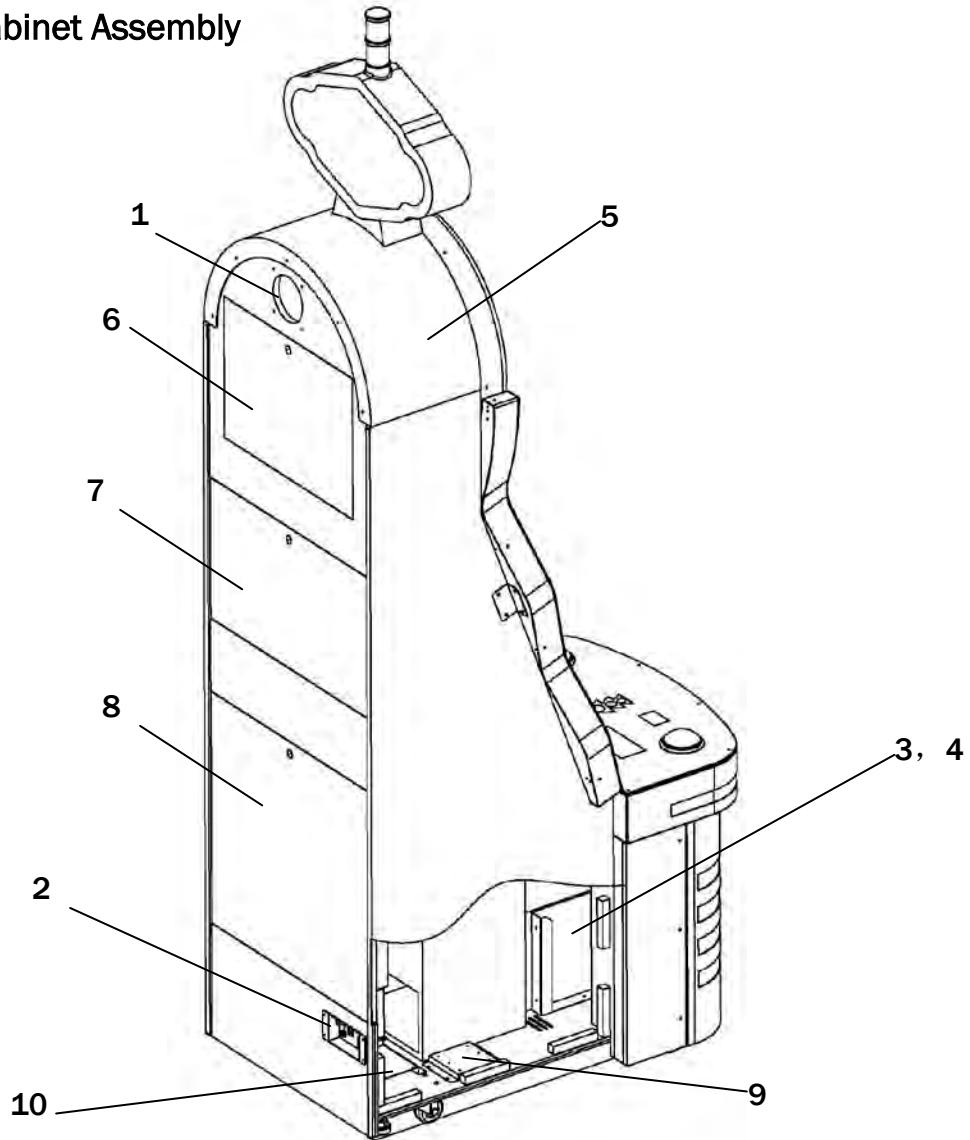

No.	Part No.	Diagram No.	Name	QTY	Spec.	Note
1	P110-119-000	TY-JX-014	Top vent	1	Q235,black,δ1.5	
2	P110-120-000	TY-JX-005	Power outlet	1	Q235,black,δ1.5	
3	P110-121-000	TY-JX-006	Ticket bin 243	2	Q235,white,δ1	
4	P110-118-000	TY-JX-020	Ticket bin bracket	2	Q235,black,δ1	
5	P110-110-000	BBGS-01-23	Top arc cover	1	Q235, black,δ1, ,δ2	
6	P110-504-000	BBGS-01-35M	Upper rear door	1	MDF, black	
7	P110-505-000	BBGS-01-34M	Middle rear door	1	MDF, black	
8	P110-506-000	BBGS-01-33M	Bottom rear door	1	MDF, black	
9	P110-106-000	BBGS-00-13	Controller fixed plate	1	Metal	
10	P110-103-000	TY-JX-032	PC power fix bracket	1	Metal	



### 8.4 Side Light Assembly

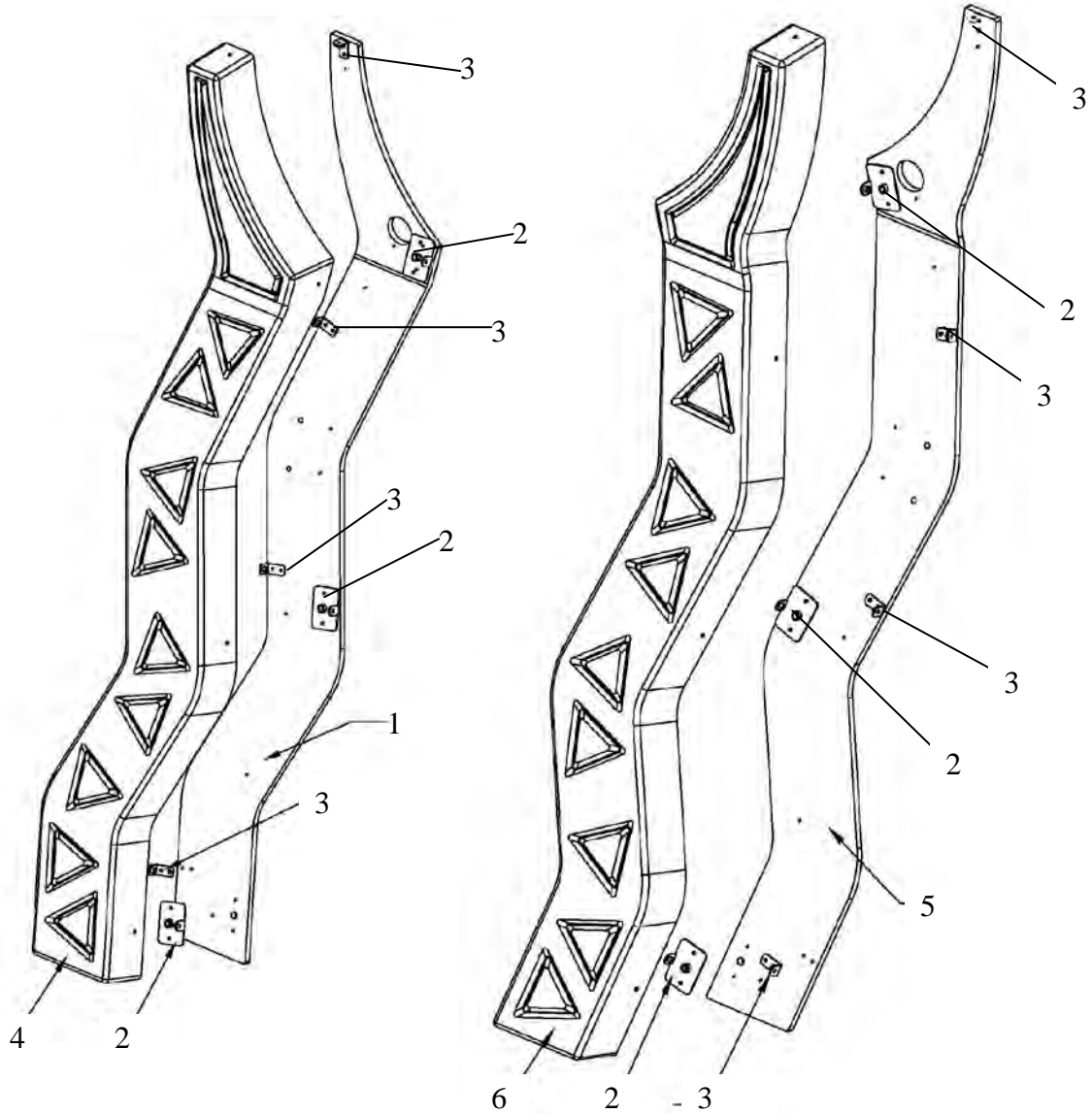

No.	Part No.	Diagram No.	Name	QTY	Spec.	Note
1	P110-604-000	BBGS-07-01	Side light bed plate -L	1	White plastic, δ8	
2	P110-122-000	BBGS-06-02	Light fixed plate	6	Metal, δ1.5	
3	P110-123-000	BBGS-02-01	Light cover fixed plate	8	Metal, δ1.5	
4	P110-605-000	BBGS-07-02	Light cover-L	1	White plastic, δ3	
5	P110-606-000	BBGS-06-01	Side light bed plate-R	1	White plastic, δ8	
6	P110-607-000	BBGS-06-03	Light cover-R	1	White plastic, δ3	

## 8.5 Top Wheel Assembly

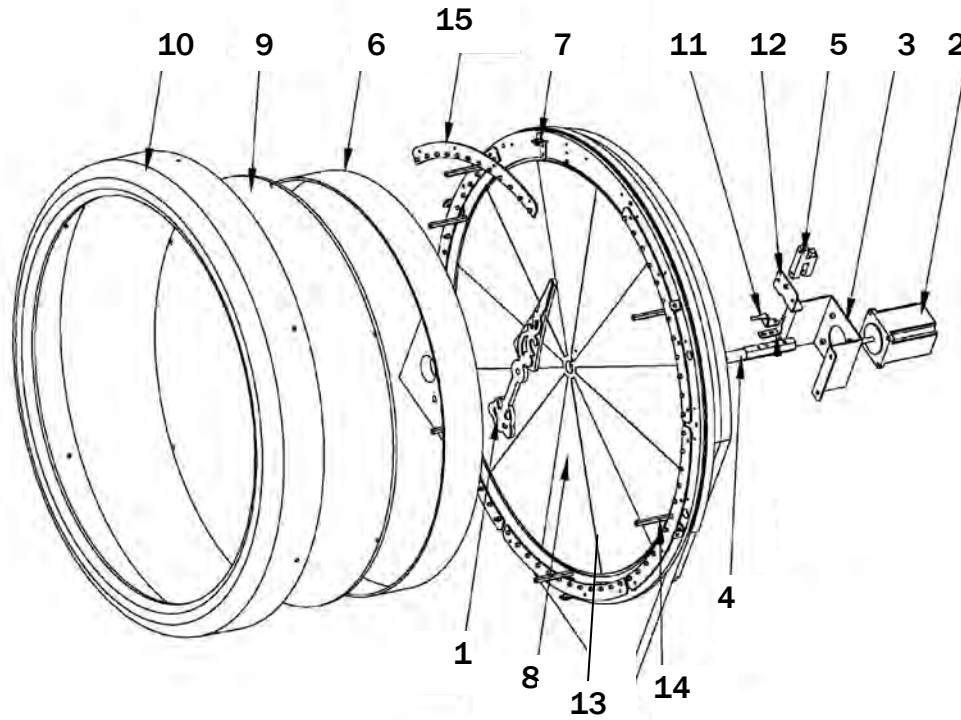

No.	Part No.	Drawing No.	Name	Qty	Spec.	Note
1	P110-608-000	BBGS-00-23	Pointer A	1	Yellow plastic, $\delta 5$	
2	P110-414-000	23406000006	Stepper motor	1	57HS09	
3	P110-124-000	BBGS-00-20	Motor bracket	1	Q235,black, $\delta 1.5$	
4	P110-125-000	BBGS-00-21	Pointer shaft	1	Hexagon brass, 16	
5	P110-415-000	21503000021	Sensor	1	YENOX (NO-5V)	
6	P110-609-000	BBGS-02-02	Top wheel circle	1	White plastic, $\delta 3$	
7	P110-126-000	BBGS-02-01	Light cover fixed plate	6	Metal, $\delta 1.5$	
8	P110-416-000	20711012006	Top wheel light	1	BBGS-C2.PCB(V1.0)	
9	P110-610-000	BBGS-02-03	Top wheel plate	1	$\delta 5$ clear plastic	
10	P110-611-000	BBGS-00-14	Top wheel cover	1	White plastic, $\delta 3$	
11	P110-127-000	BBGS-00-22	Sensor block	1	$\delta 5$ Metal	
12	P110-128-000	BBGS-00-07	Sensor fixed plate	1	$\delta 1.2$ Metal	
13	P110-129-000	BBGS-00-27	Light separator A	12	$\delta 1$ Aluminum	
14	P110-130-000	20108020003	Hex bolt	6	Brass	
15	P110-417-000	20711012005	Top wheel side light	6	BBGS-C1.PCB(V1.0)	

## 8.6 Middle Wheel Assembly

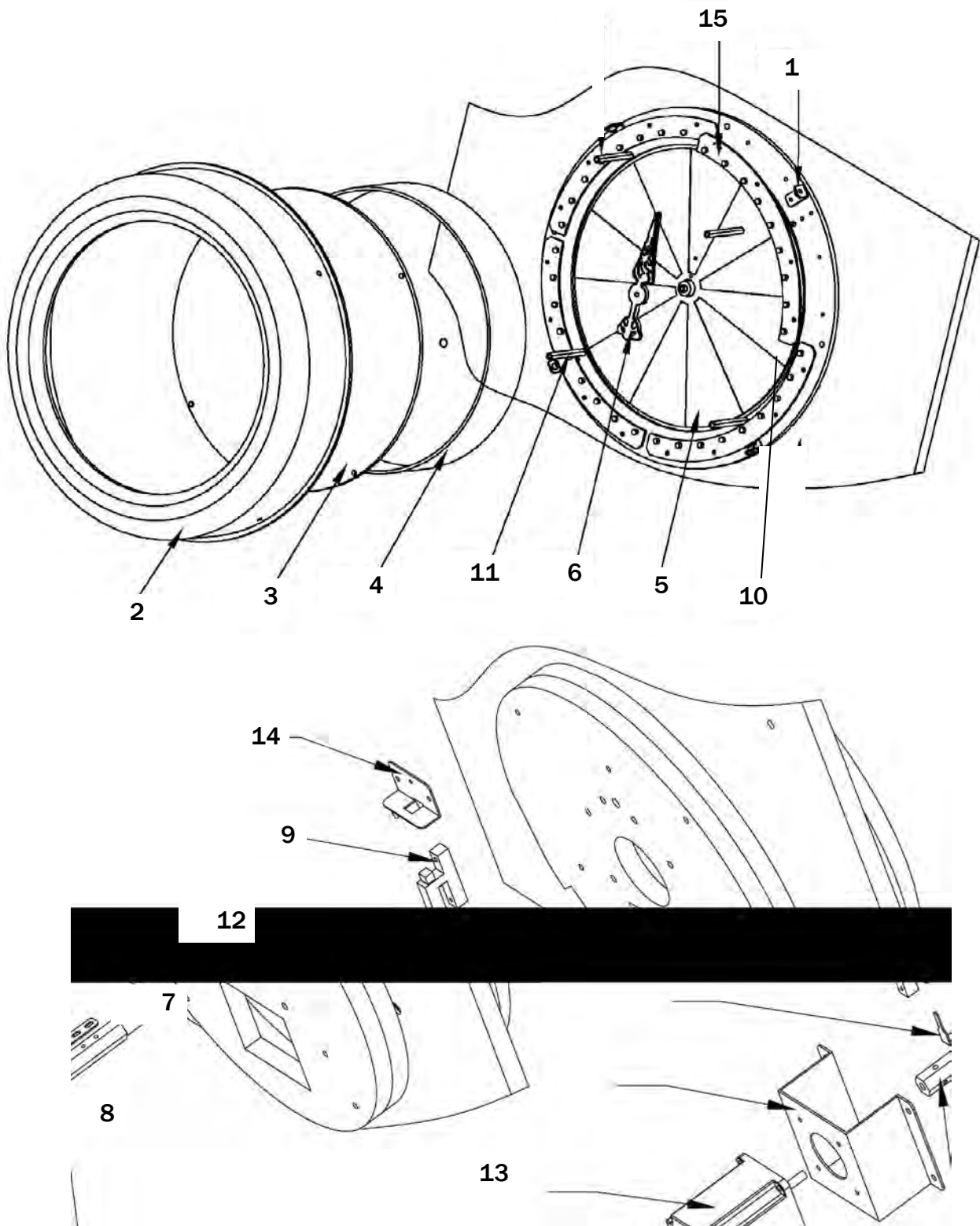

No.	Part No.	Diagram No.	Name	Qty.	Spec.	Note
1	P110-131-000	BBGS-02-01	Light cover fixed plate	4	Metal, δ1.5	
2	P110-612000	BBGS-00-15	Middle wheel cover	1	White plastic, δ3	
3	P110-613-000	BBGS-03-01	Middle wheel plate	1	δ5 clear plastic	
4	P110-614000	BBGS-03-02	Middle wheel circle	1	White plastic, δ3	
5	P110-418-000	20711012004	Middle wheel light	1	BBGS-B2.PCB(V1.0)	
6	P110-615-000	BBGS-00-24	Pointer B	1	δ5 yellow plastic	
7	P110-132-000	BBGS-00-20	Motor bracket	1	Q235 black	
8	P110-419-000	23406000006	Stepper motor	1	57HS09	
9	P110-420-000	21503000021	Sensor	1	YENOX (NO-5V)	
10	P110-133000	BBGS-00-28	Light separator B	12	δ1 Aluminum	
11	P110-134000	20108020003	Hex bolt	4	Brass	
12	P110-135-000	BBGS-00-22	Sensor block	1	δ5 Metal	
13	P110-136-000	BBGS-00-21	Point shaft	1	Hexagon brass, 16	
14	P110-137-000	BBGS-00-07	Sensor fixed plate	1	δ1.2 Metal	
15	P110-421-000	20711012003	Middle wheel side light	4	BBGS-B1.PCB(V1.0)	

## 8.7 Bottom Wheel Assembly

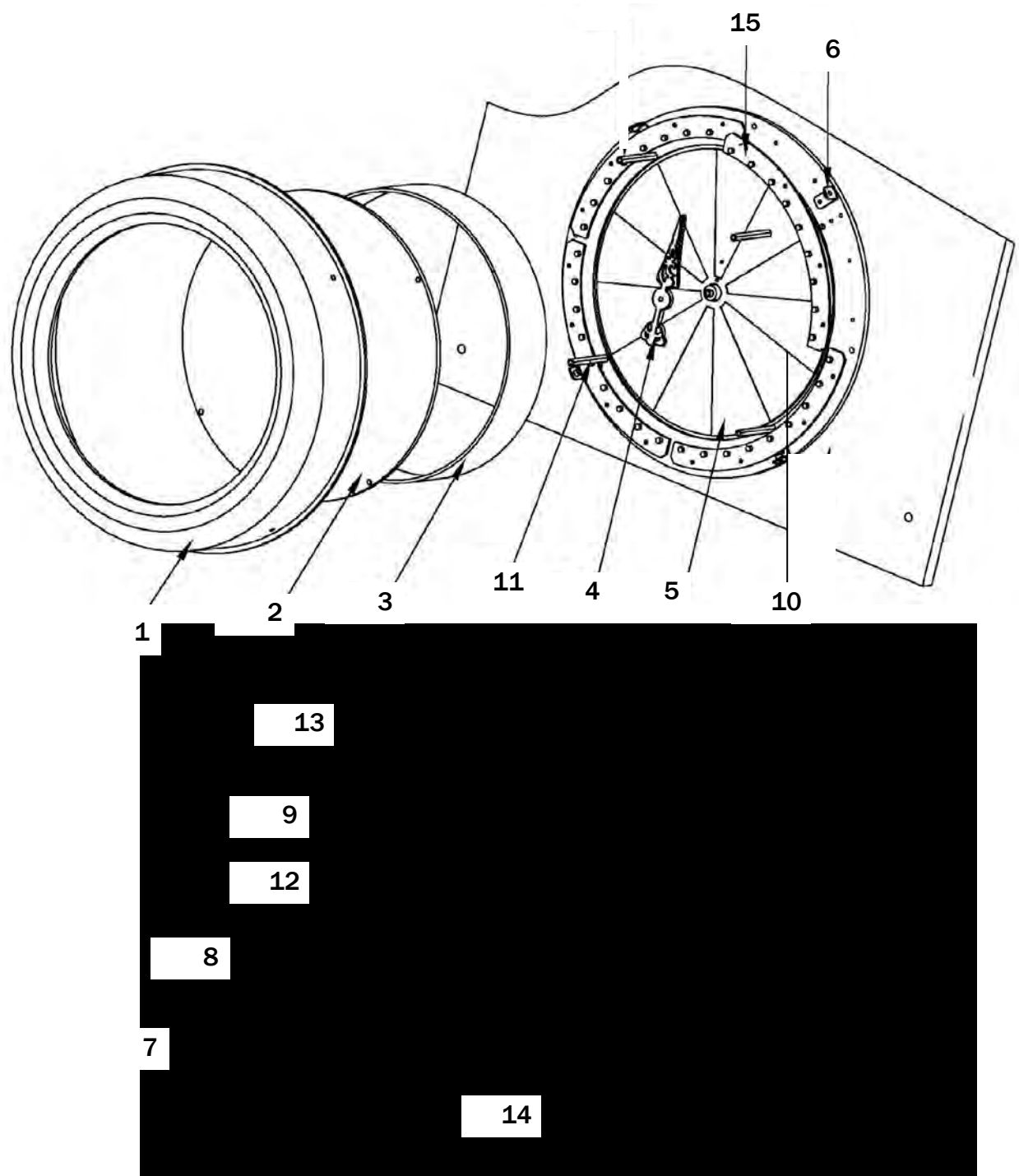

No.	Part No.	Diagram No.	Name	Qty.	Spec.	Note
1	P110-616-000	BBGS-00-16	Bottom wheel cover	1	White plastic, $\delta 3$	
2	P110-617-000	BBGS-04-01	Bottom wheel plate	1	Clear plastic, $\delta 5$	
3	P110-618-000	BBGS-04-02	Bottom wheel circle	1	White plastic, $\delta 3$	
4	P110-619-000	BBGS-00-25	Pointer C	1	Yellow plastic, $\delta 5$	
5	P110-422-000	20711012002	Bottom wheel light	1	BBGS-A2.PCB(V1.0)	
6	P110-138-000	BBGS-02-01	Light cover fixed plate	4	Metal, $\delta 6$	
7	P110-423-000	23406000006	Stepper motor	1	57HS09	
8	P110-139-000	BBGS-00-20	Motor bracket	1	Q235 black	
9	P110-424-000	21503000021	Sensor	1	YENOX (NO-5V)	
10	P110-140-000	BBGS-00-29	Light separator C	1	$\delta 1$ Aluminum	
11	P110-141-000	20108020003	Hex bolt	4	Brass	
12	P110-142000	BBGS-00-22	Sensor block	1	$\delta 5$ Metal	
13	P110-143-000	BBGS-00-07	Sensor fixed plate	1	$\delta 1.2$ Metal	
14	P110-144-000	BBGS-00-21	Pointer shaft	1	Hex brass, 16	
15	P110-425-000	20711012001	Bottom wheel side light	4	BBGS-A1.PCB(V1.0)	

## 8.8 Counter & Wire Box

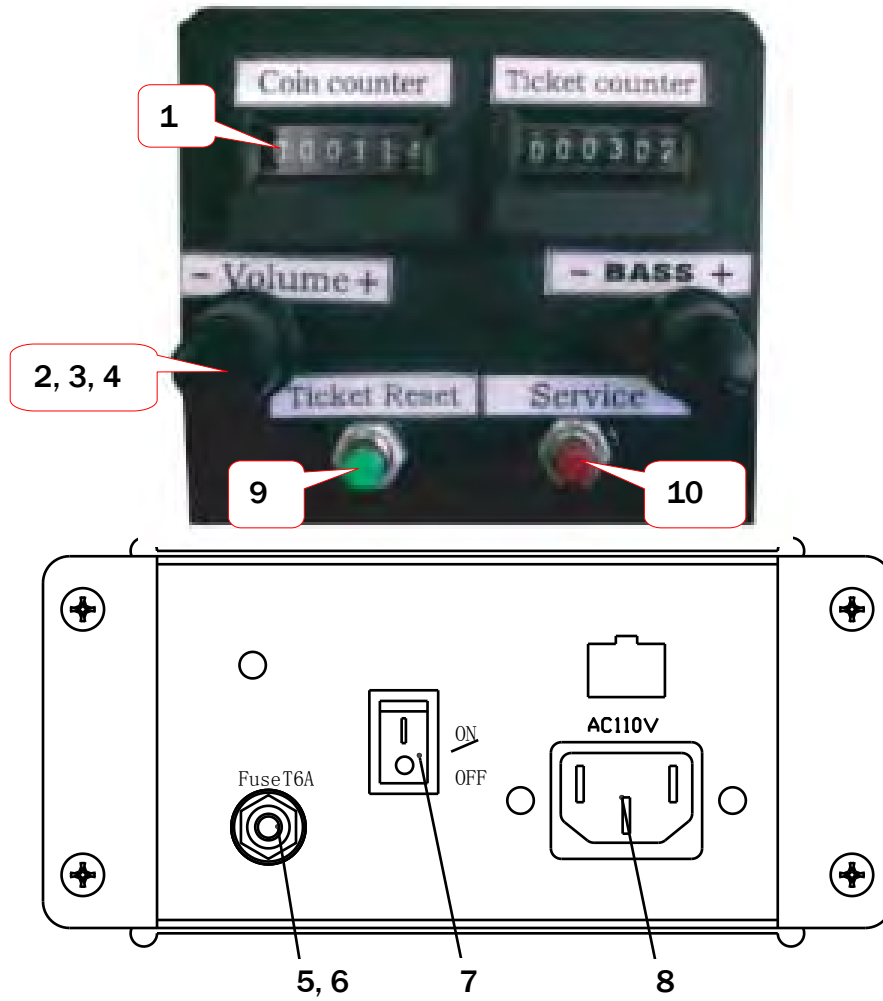

No.	Part No.	Diagram No.	Name	Qty.	Spec.	Note
1	P110-426-000	23000000005	Counter	1	C-012 DC12V	
2	P110-427-000	22403000001	Pot. knob	2	Black	
3	P110-428-000	21709000002	Pot. Connect board	2	VR.PCB	
4	P110-429-000	23301000020	POT	2	10K	
5	P000-402-000	21901000012	Fuse	1	Φ5×20mm T5A 250VAC	
6	P110-430-000	21902000006	Fuse holder	1	R3-11 110V/250V/10A	
7	P110-431-000	22601000005	Rocker SW	1	T125/55	
8	P110-432-000	23201000009	Noise filter	1	10SS1-PB 115/250V10A	
9	P110-433-000	22402010002	Button	1	DS-316 (green)	
10	P110-434-000	22402010002	Button	1	DS-316 (red)	



### 8.9 Electrical Parts

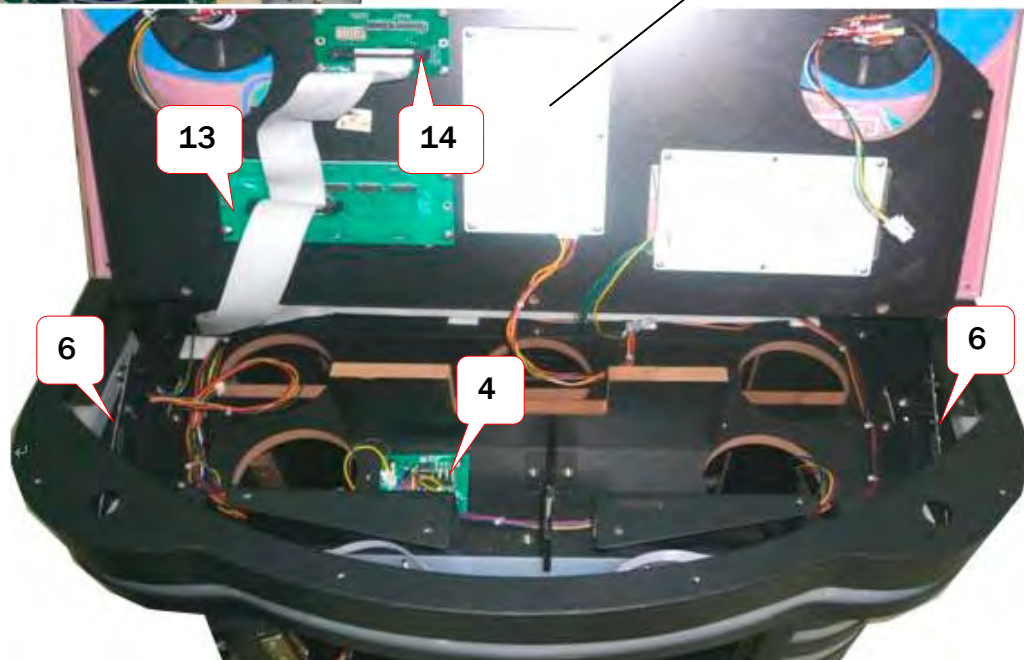
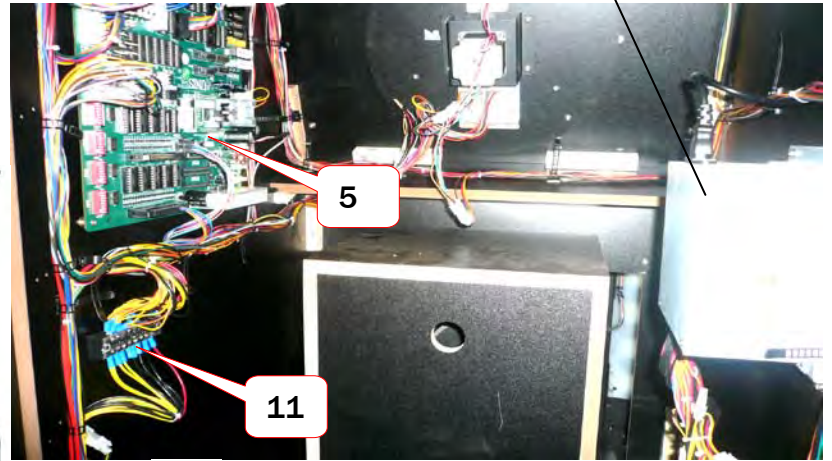
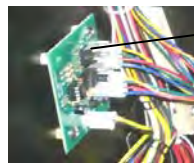
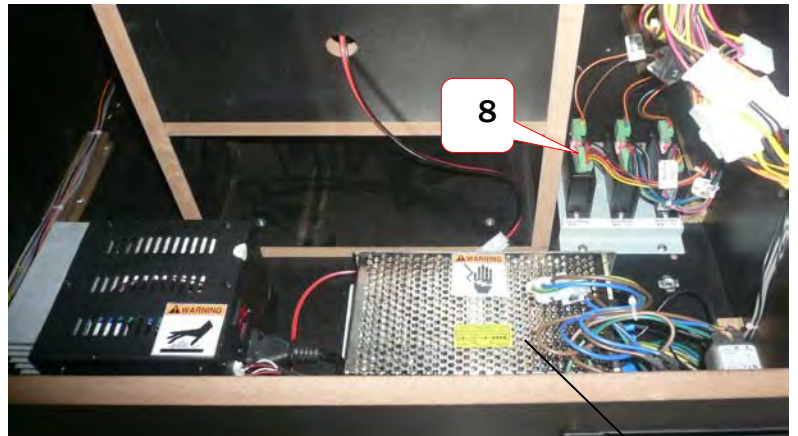



No.	Part No.	Diagram No.	Name	Qty.	Spec.	Note
1	P110-435-000	21602000010	Power supply	1	EPT-S150S24	
2	P110-436-000	21602000001	Power supply	1	BTX-3039(110V220V)	
3	P110-437-000	20711012008	Arrow light board	1	BBGS-JTLED.PCB(V1.0)	
4	P110-438-000	20711012008	LED board	2	BBGS-JTLED.PCB(V1.0)	
5	P110-439-000	21701000014	Main board	1	PLAYV9	
6	P110-440-000	20740910001	Control panel light board	5	YHYX-LED01.PCB(V1.1)	
7	P110-441-000	22002013002	RGB flex light belt	2	DC12V 5050LED/m=60	
8	P110-442-000	22900000005	Stepper motor driver	3	2M415	
9	P110-443-000	22801000004	Bass speaker	1	AZ-6 8" 8Ω150W	
10	P110-444-000	22801000005	Speaker	2	4" 4Ω 15W	
11	P110-445-000	21902000023	Terminal block	1	TB-1508, 8P	
12	P110-456-000	21706000034	BONUS LED	1	LED23B4.PCB	
13	P110-447-000	21706000037	Ticket LED	1	LED23B3.PCB	
14	P110-448-000	21706000050	Coin LED	1	LED15B2.PCB	

### 8.10 Game Decals

Front :

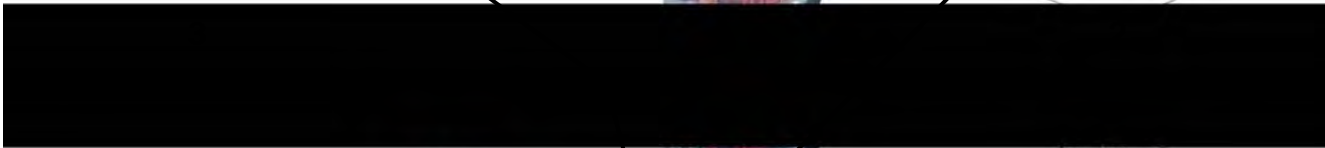

No.	Part No.	Diagram No.	Name	Spec.	Qty.	Note
1	P110-700-000	BBGS-HM-05E	Marquee decal	δ5Clear plastic	1	
2	P110-701-000	BBGS-HM-02E	Top wheel decal	δ6Clear plastic	1	
3	P110-702-000	BBGS-HM-03E	Middle wheel decal	δ6Clear plastic	1	
4	P110-703-000	BBGS-HM-04E	Bottom wheel decal	δ6Clear plastic	1	
5	P110-704-000	BBGS-HM-13E	Collect & quit button decal	White PVC100u glue	2	
6	P110-705-000	BBGS-HM-14E	Start or Stop button decal	White PVC100u glue	1	
7	P110-706-000	BBGS-HM-07E	Side decal - L	White PVC100u glue	1	
8	P110-707-000	BBGS-HM-08E	Side decal - R	White PVC100u glue	1	
9	P110-708-000	BBGS-HM-01E	Control panel decal	δ5Clear plastic	1	
10	P110-709-000	BBGS-HM-06E	Front door decal	White PVC100u glue	1	
11	P110-710-000	BBGS-HM-12E	Ticket exit decal	White PVC100u glue	1	
12	P110-711-000	TY-HM-01	Coin counter sticker	White PVC100u glue	1	
13	P110-712-000	TY-HM-02	Ticket counter sticker	White PVC100u glue	1	
14	P110-713-000	TY-HM-03	Vol. sticker	White PVC100u glue	1	
15	P110-714-000	TY-HM-08	Ticket reset sticker	White PVC100u glue	1	
16	P110-715-000	TY-HM-09	Service sticker	White PVC100u glue	1	
17	P110-716-000	TY-HM-04	Bass sticker	White PVC100u glue	1	

Back :

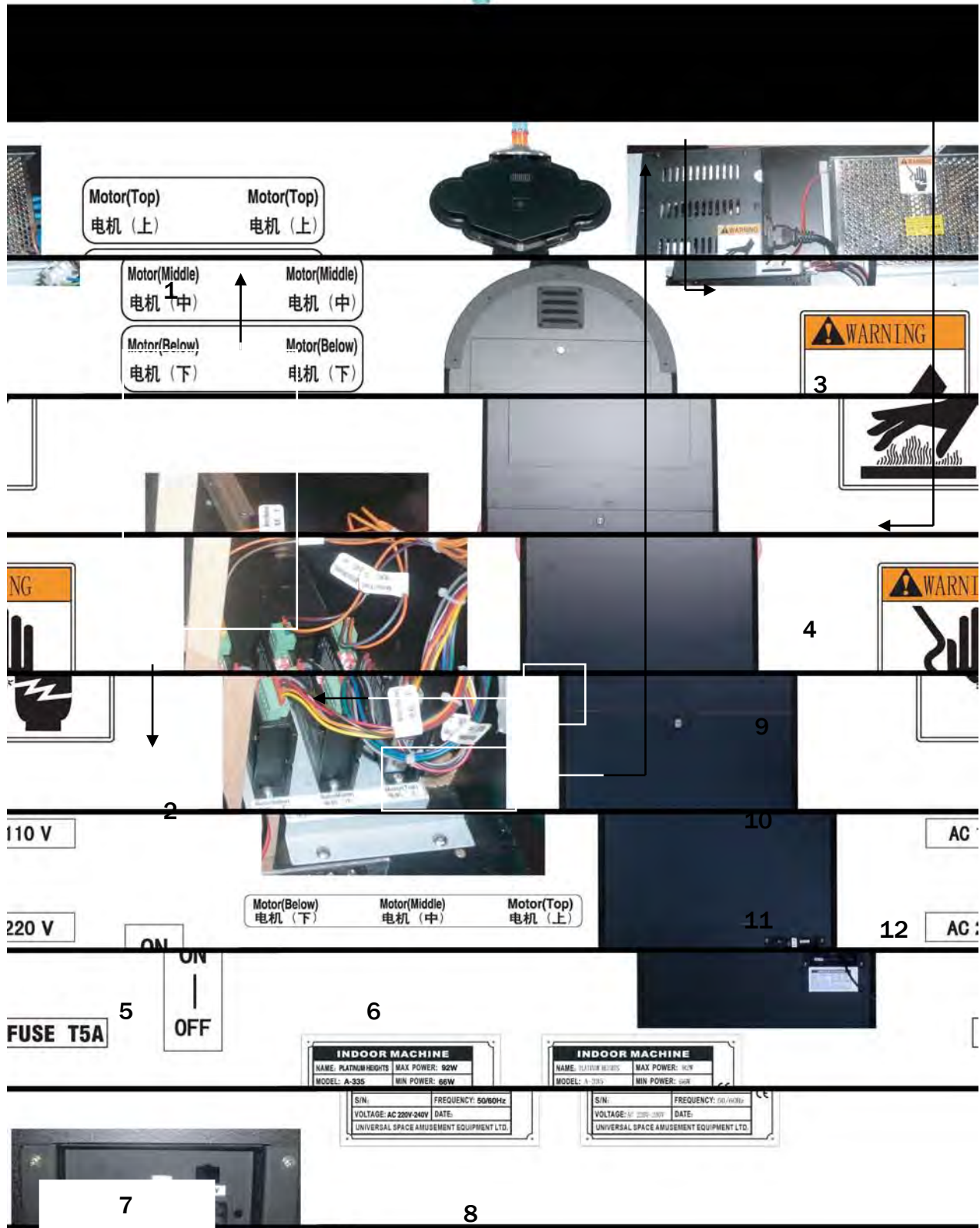

No.	Part No.	Diagram No.	Name	Spec.	Qty.	Note
1	P110-717-000	BBGS-HM-16	Motor driver sticker	White PVC100u glue	2	
2	P110-718-000	BBGS-HM-15	Motor sticker	White PVC100u glue	1	
3	P110-719-000	TY-HM-38	Warning sticker - S	White PVC100u glue	1	
4	P110-720-000	TY-HM-36	High voltage warning sticker - S	White PVC100u glue	1	
5	P110-721-000	BBGS-HM-17E	220V nameplate	δ0.5 Aluminum	1	
6	P110-723-000	BBGS-HM-18E	CE certified nameplate	δ0.5 Aluminum	1	
7	P110-724-000	BBGS-HM-20E	110V nameplate	δ0.5 Aluminum	1	
8	P110-725-000	BBGS-HM-19E	FCC certified nameplate	δ0.5 Aluminum	1	
9	P110-726-000	TY-HM-40	110V label	White PVC100u glue	1	
10	P110-727-000	TY-HM-41	220V label	White PVC100u glue	1	
11	P110-728-000	TY-HM-11	Fuse T5A sticker	White PVC100u glue	1	
12	P110-729-000	TY-HM-16	Power SW sticker A	White PVC100u glue	1	



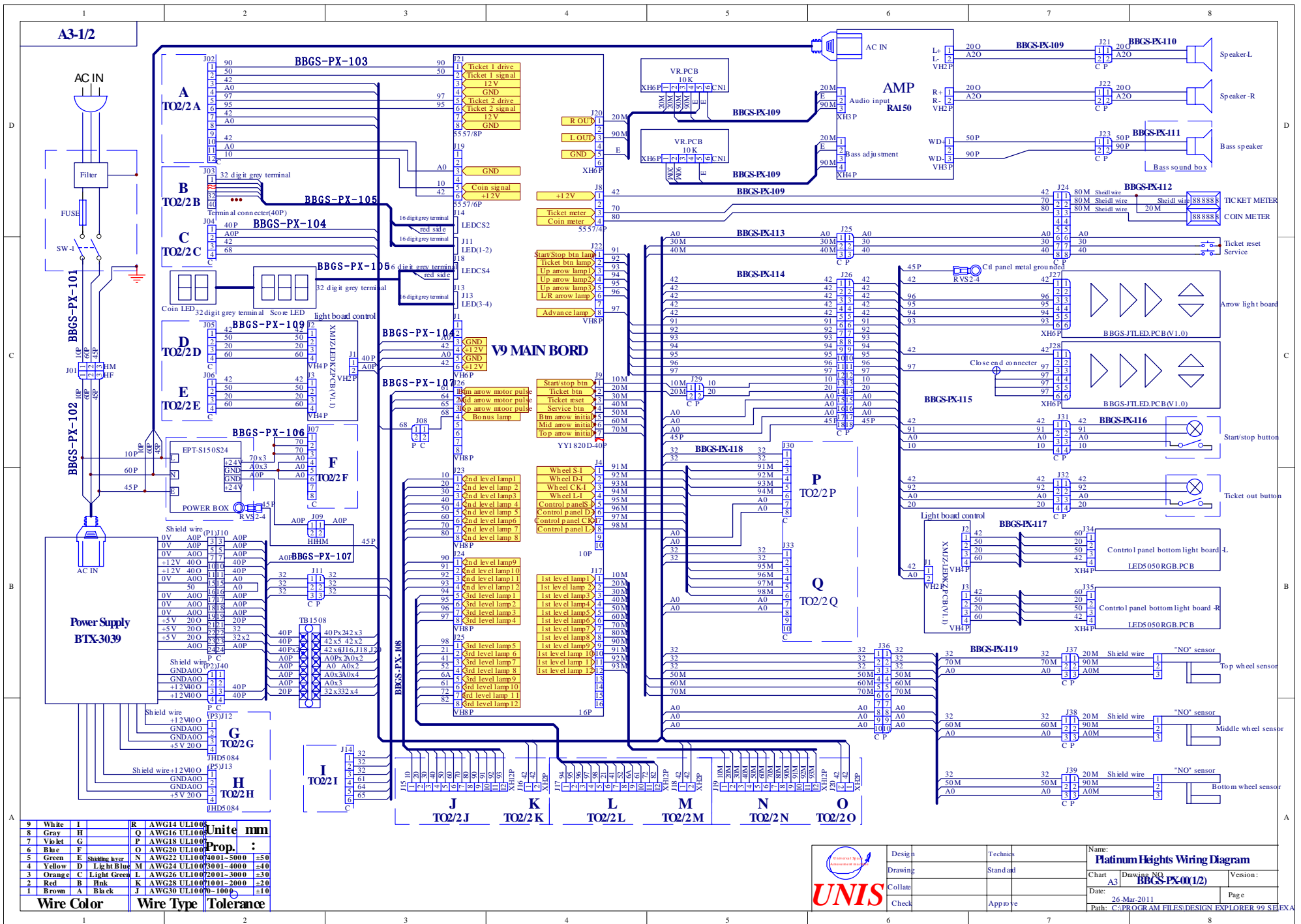

**UNIS** Design | Technics | Stand | Appr | Name: Platinum Heights Wiring Diagram

Chart: A3 | Drawing NO: BBGS-PX-00(1/2) | Version: | Date: 26-Mar-2011 | Page: | Path: C:\PROGRAM FILES\DESIGN EXPLORER 99 SEBEXA

