

WHEEL DEAL

BENCHMARK GAMES INC. ALL RIGHT RESERVED. PAT. PEND.

OWNER'S MANUAL BENCHMARK GAMES, INC

PLEASE READ
FIRST BEFORE
PLUGGING IN
MACHINE



FOR SERVICE

PLEASE CALL: 561-588-5200
FAXES-MAIN: 561-493-2999, PARTS: 561-493-2990

BENCHMARK GAMES, INC.
51 Hypoluxo Road, Hypoluxo, FL 33462
www.benchmarkgames.com
alkress@benchmarkgames.com

WARNING.....	4
GAME DESCRIPTION.....	5
GAMEPLAY.....	5
WHEEL DEAL SETUP.....	6
COIN MECH SETUP.....	7
WHEEL DEAL PROGRAMMING.....	8
PLAYFIELD ASSEMBLY AND ADJUSTMENTS.....	9
FLOURESCENT LIGHTS.....	10
TROUBLESHOOTING GUIDE.....	11
TROUBLESHOOTING GUIDE CONT' D.....	12
CPU BOARD BLOCK DIAGRAM.....	13
EXPANSION BOARD.....	14
Schematic:.....	14
4 DIGIT JACKPOT DISPLAY PLAYER 1.....	15
4 DIGIT TICKETS OWNED DISPLAY PLAYER 1.....	15
4 DIGIT JACKPOT DISPLAY PLAYER 2	16
Schematic:.....	16
4 DIGIT TICKETS OWNED DISPLAY PLAYER 2	16
4 DIGITAL JACKPOT DISPLAY PLAYER 3.....	16
4 DIGIT TICKETS OWNED DISPLAY PLAYER 3	17
Schematic:.....	17
PLAYER 1 HOME OPTO SENSORS.....	17
PLAYER 2 HOME OPTO SENSORS.....	17
PLAYER 2 COIN OPTO SENSORS	18
Schematic:.....	18
PLAYER 3 HOME OPTO SENSORS.....	18
PLAYER 3 COIN OPTO SENSORS.....	18
Schematic:.....	19
STEPPER CONTROLLER.....	19
Schematic:.....	21
SPIRAL FLOURESCENT AND INCANDESCENT LIGHTS PLAYER 1.....	21
SPIRAL FLOURESCENT AND INCANDESCENT LIGHTS PLAYER 2.....	21
SPIRAL FLOURESCENT AND INCANDESCENT LIGHTS PLAYER 3.....	21
Schematic:.....	22
SPEAKER PLAYER 1	J301.....22
SPEAKER PLAYER 3.....	22
SPEAKER PLAYER 2	J301.....22
COUNTERS.....	22
Schematic:.....	23
PLAYER 1 TICKET DISPENSER.....	23
PLAYER 2 TICKET DISPENSER.....	23
PLAYER 3 TICKET DISPENSER.....	23
LOW TICKET LIGHTS.....	23
Schematic:.....	24

DEAR CUSTOMER:

THANK YOU FOR PURCHASING A WHEEL DEAL GAME.

BECAUSE OF THE DIFFERENT NEEDS OF EVERY LOCATION, YOU MAY NEED TO FINE TUNE THE MACHINE IN THE FUTURE. WE STRONGLY SUGGEST THAT YOU LEAVE THE MACHINE AT FACTORY SETTINGS FOR AT LEAST 2 TO 3 WEEKS. IF YOU THEN FIND YOUR PAYOUT TOO LOW OR TOO HIGH, THEN MAKE THE PROPER ADJUSTMENTS. START FIRST WITH THE FACTORY DEFAULT SETTINGS.

YOU WILL FIND ENCLOSED IN THE MANUAL A SET OF INSTRUCTIONS ON HOW TO PROGRAM YOUR MACHINE.

PLEASE READ THE MANUAL BEFORE YOU CALL US FOR ANY INFORMATION. WHEN YOU CALL PLEASE HAVE THE SERIAL NUMBER FOR YOUR GAME IN HAND.

**BENCHMARK GAMES, INC.
51 HYPOLUXO RD.
HYPOLUXO, FL 33462
561-588-5200
PARTS FAX: 561-493-2990**

WARNING:

DO NOT TURN GAME ON UNTIL THE FOLLOWING WARNINGS ARE READ AND UNDERSTOOD.

FAILURE TO ADHERE TO THE FOLLOWING INSTRUCTIONS WILL VOID ANY FACTORY WARRANTIES AND COULD RESULT IN DAMAGE TO THE GAME AND OR INJURY TO THE PLAYER OR TECHNICIAN.

THIS GAME SHOULD BE PLUGGED INTO A 3 WIRE GROUNDED OUTLET 115VAC 60 HZ. UNLESS OTHERWISE SPECIFIED.

FCC PART 15 RULE:

THIS EQUIPMENT HAS BEEN TESTED AND FOUND TO COMPLY WITH THE LIMITS FOR A CLASS A COMPUTING DEVICE PURSUANT TO SUB-PART J OF PART 15 OF FCC RULES.

ELECTRICAL SPECIFICATIONS:
POWER CONSUMPTION
100-130VAC 60HZ. LINE FUSE

1.5 AMP 180 WATT LINE VOLTAGE
5 AMP

COPYRIGHT © 2001 BENCHMARK GAMES. ALL RIGHTS RESERVED

THE GAME, TECHNICAL MANUAL, GRAPHIC DESIGNS AND SCHEMATIC DIAGRAMS ARE PROTECTED BY THE U.S. COPYRIGHT ACT OF 1979. BENCHMARK GAMES WILL ENFORCE ITS COPYRIGHT AND PATENTS AGAINST INFRINGERS.

GAME DESCRIPTION

THERE ARE 3 ROTATING PLAYFIELDS THAT TURN AT A CONSTANT SPEED. THE 4 DIGIT LED'S AT THE TOP OF EACH PLAYER KEEPS TRACK OF THE JACKPOT AMOUNT AND THE TICKETS OWED. COINS CAN BE INSERTED AS FAST AS THE PLAYER CAN INSERT THEM. THE 2 CHANNEL SOUND SYSTEM PLAYS THE MUSIC OUT OF THE CENTER SPEAKER AND THE SOUND EFFECTS OUT OF THE 2 END SPEAKERS.

GAMEPLAY

THE PLAYER INSERTS A COIN INTO THE GAME, THE COIN THEN SLIDES DOWN THE COIN RAMPS ONTO THE ROTATING PLAYFIELD. THE ROTATING PLAYFIELD CAUSES THE COIN TO REST ON THE END OF THE COIN POINTER ON A TICKET VALUE OR JACKPOT AREA. AN OPTO SENSOR THEN READS THE POSITION THAT THE COIN LANDED ON AND PAYS OUT THE APPROPRIATE AMOUNT OF TICKETS. THE COIN THEN CONTINUES AROUND THE PLAYFIELD UNTIL IT IS WIPED OFF THE PLAYFIELD INTO THE CASHBOX. THE PROGRESSIVE JACKPOT COUNTER WILL INCREMENT FOR EVERY COIN PLAYED AND WILL PAY OUT WHEN THE COIN LANDS ON A JACKPOT AREA. THE OTHER 4 DIGIT LED KEEPS TRACK OF THE TICKETS OWED.

VER. 01.8

WHEEL DEAL SETUP

1. REMOVE GAME FROM BOX.
2. OPEN CENTER PLAYER WOOD DOOR AND REMOVE CASHBOX. REMOVE THE POWER PLUG AND 3 SPINNER ASSEMBLIES.
3. REMOVE THE GLASS FROM ALL 3 PLAYERS BY UNLOCKING BOTH LOCKS, (NOTE: WHEN YOU REMOVE THE GLASS, THE COIN MECH'S WILL BECOME UNPLUGGED).
4. INSTALL THE 3 WHEELED HUB ONTO THE CENTER SHAFTS OF THE ROTATING PLATTERS, THEN INSTALL THE ALUMINUM SPINDLES ON TOP OF THE HUBS.
5. REASSEMBLE THE GLASS ON ALL 3 PLAYERS,(MAKING SURE YOU PLUG IN THE COIN MECHS WHILE INSTALLING THE GLASS).
6. USING THE POWER PLUG, PLUG IN THE GAME ON THE RIGHT SIDE OF THE GAME ON THE OUTSIDE AND TURN POWER SWITCH ON,(LOCATED WHERE THE PLUG GOES INTO THE CABINET).

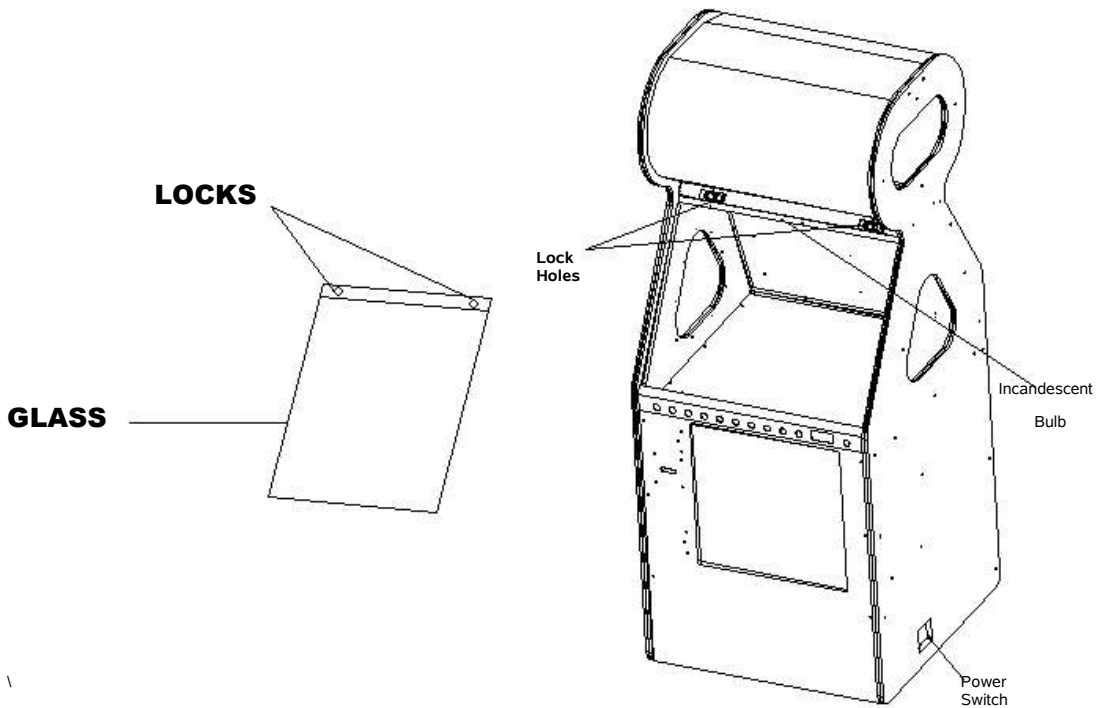

COIN MECH SETUP

WHEEL DEAL USES A COIN COMPARATOR. A SAMPLE COIN MUST BE INSERTED AND LEFT IN THE MECH AS SHOWN BELOW. WHEN THE PLAYER INSERTS A COIN FOR GAMEPLAY, THE MASS OF THE COIN IS MEASURED AGAINST THE SAMPLE COIN AND IS ACCEPTED OR REJECTED.

THE COIN MECH SWITCH ON THE SIDE MUST BE SET TO N.O.(NORMALLY OPEN), NOT N.C. (NORMALLY CLOSED).

THE PULSE TIME 3 POSITION SWITCH SHOULD BE SET AT THE SHORTEST PULSE TIME.

THERE IS A SENSITIVITY ADJUSTMENT ON THE SIDE OF THE MECH. STRICT MAKES THE MECH MORE DISCREET,(WILL REJECT MORE COINS IF THEY ARE NOT PERFECT). SLACK MAKES THE MECH NOT SO DIFFICULT ABOUT THE COINS IT WILL ACCEPT.

WHEEL DEAL PROGRAMMING

THE BUTTONS USED FOR PROGRAMMING ARE ON THE POWER DISTRIBUTION BLOCK. THEY ARE 3 SMALL BLACK PUSH BUTTONS, (UNDERNEATH THE COMPUTER ON THE SAME BOARD AS THE FUSES).

1. Press the bottom button ONCE to go into programming mode.
2. Press the top button to go to the mode you want to set.(shown on the left led's of player 1).
3. Press the bottom button to lock the mode for changing.
4. Use the middle and top buttons to adjust the value of that mode,(shown on the right led's of player 1).
5. Hit the bottom button to set the change,(the right led's flashes oH).
6. Press the top button until the leds say ehit on the left led.(short for exit).
7. Press the bottom button one more time, then either turn the game off and on, or put in a coin to play the game. The changes are now locked into memory.

MODES:

- 0000 DEFAULT,(WILL SET GAME BACK TO FACTORY DEFAULT PROGRAMMING). TO USE: CHANGE VALUE OF MODE TO 2, PRESS BOTTOM BUTTON AND EXIT PROGRAMMING NORMALLY.
- 0001 WHEEL RPM. THIS WILL SPEED UP OR SLOW DOWN ALL 3 WHEELS,(FASTER IS HARDER). RANGE IS 70-80. NOTE: SPEED WILL NOT CHANGE UNTIL AFTER YOU EXIT AND RESTART THE GAME).
- 0002 NOT USED
- 0003 MINIMUM JACKPOT FOR PLAYER 1,(RIGHT CABINET), THIS IS HOW MUCH THE JACKPOT START STARTS AT AFTER THE JACKPOT HAS BEEN WON. IT IS IN MULTIPLES OF 2. EG: SETTING IT TO 50 WILL START THE JACKPOT AT 100 SETTING IT TO 100 WILL START THE JACKPOT AT 200. FACTORY SETTING IS 75 SO IT STARTS AT 150.
- 0004 MINIMUM JACKPOT FOR PLAYER 2,(MIDDLE CABINET), THIS IS HOW MUCH THE JACKPOT START STARTS AT AFTER THE JACKPOT HAS BEEN WON. IT IS IN MULTIPLES OF 2. EG: SETTING IT TO 50 WILL START THE JACKPOT AT 100 SETTING IT TO 100 WILL START THE JACKPOT AT 200. FACTORY SETTING IS 75 SO IT STARTS AT 150.
- 0005 MINIMUM JACKPOT FOR PLAYER ,(RIGHT CABINET), THIS IS HOW MUCH THE JACKPOT START STARTS AT AFTER THE JACKPOT HAS BEEN WON. IT IS IN MULTIPLES OF 2. EG: SETTING IT TO 50 WILL START THE JACKPOT AT 100 SETTING IT TO 100 WILL START THE JACKPOT AT 200. FACTORY SETTING IS 75 SO IT STARTS AT 150.
- 0006 JACKPOT INCREMENTER FOR PLAYER 1,(RIGHT CABINET). THIS IS HOW MUCH THE JACKPOT INCREMENTS EVERY TIME YOU PUT A COIN IN THE RIGHT CABINET. RANGE IS 1-10.
- 0007 JACKPOT INCREMENTER FOR PLAYER 2,(MIDDLE CABINET). THIS IS HOW MUCH THE JACKPOT INCREMENTS EVERY TIME YOU PUT A COIN IN THE CENTER CABINET. RANGE IS 1-10
- 0008 JACKPOT INCREMENTER FOR PLAYER 3,(LEFT CABINET). THIS IS HOW MUCH THE JACKPOT INCREMENTS EVERY TIME YOU PUT A COIN IN THE LEFT CABINET. RANGE IS 1-10
- 0009 THIS IS THE MAXIMUM VALUE THE JACKPOT FOR PLAYER 1 CAN GET TO IN MULTIPLES OF 250. EG: A VALUE OF 4 IN THIS MODE WILL SET THE MAX JACKPOT TO 1000 TICKETS.
- 0010 THIS IS THE MAXIMUM VALUE THE JACKPOT FOR PLAYER 2 CAN GET TO IN MULTIPLES OF 250. EG: A VALUE OF 4 IN THIS MODE WILL SET THE MAX JACKPOT TO 1000 TICKETS.
- 0011 THIS IS THE MAXIMUM VALUE THE JACKPOT FOR PLAER 3 CAN GET TO. EG: A VALUE OF 4 IN THIS MODE WILL SET THE MAX JACKPOT TO 1000 TICKETS.
- 0012 INITIALIZE NON-VOLATILE RAM.(CLEARS TICKETS OWED). SET THE SAME WAY AS MODE 0000.(SET VALUE TO 2, THEN EXIT).
- 0013-0029 NOT USED
- 0030 EXIT MODE. (YOU MUST EXIT CORRECTLY IN ORDER FOR YOUR CHANGES TO BE LOCKED INTO MEMORY).
- 0031 NOT USED.

DIP SWITCH #7 IS FOR A MERCY TICKET. EG: IS A PERSON PLAYS A COIN BUT DOES NOT WIN ANY TICKETS, IT WILL PAY OUT 1 TICKET.

NOTE: THE GAME MUST BE TURNED OFF WHEN YOU TURN THE DIP ON.

PLAYFIELD ASSEMBLY AND ADJUSTMENTS

ADJUSTING THE COIN POINTER: IF YOUR COINS ARE GOING UNDERNEATH THE COIN POINTER BEFORE THEY GET TO THE END OF THE POINTER, OR IF YOUR ROTATING PLAYFIELD IS GETTING SCRATCHED IN A CIRCULAR PATTERN, YOU MAY NEED TO ADJUST THE COIN POINTER HEIGHT.

TO ADJUST:

1. OPEN THE WOOD FRONT DOOR AND LOCATE THE 6-32 BOLT AND FIBER NUT HOLDING THE RED PLASTIC COIN POINTER TO THE METAL BRACKET.
2. LOOSEN THE NUT AND PLACE A .012 FEELER GAUGE IN BETWEEN THE COIN POINTER AND THE ROTATING PLAYFIELD AND TIGHTEN THE NUT.
3. CHECK THE CLEARANCE AT DIFFERENT POINTS ALONG THE COIN POINTER TO MAKE SURE IT HAS EVEN CLEARANCE. RECLEARANCE AS NECESSARY.

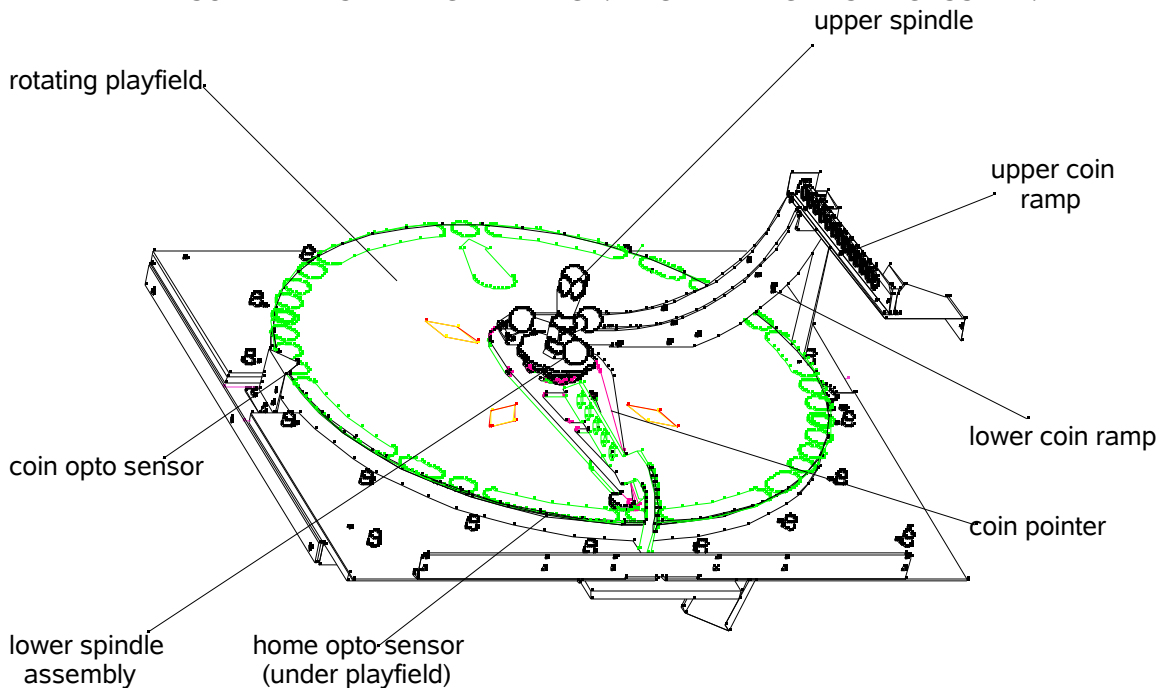

NOTE: PLEASE CALL THE FACTORY BEFORE ATTEMPTING THESE ADJUSTMENTS.
ADJUSTING THE OPTO SENSORS:

THE HOME SENSOR UNDERNEATH THE ROTATING PLAYFIELD IS SET AT FACTORY AND WILL NEVER NEED ADJUSTMENT. THERE IS A ROLL PIN PRESSED INTO THE ROTATING PLAYFIELD THAT BREAKS THE OPTO BEAM ONCE EVERY ROTATION.

THE COIN OPTO SENSOR IS ALSO SET AT THE FACTORY. IN THE EVENT YOU NEED TO ADJUST THIS SENSOR, THE BLACK METAL OPTO MOUNT HAS SLOTS IN IT SO IT CAN BE LOOSENED AND SLID FORWARDS OR BACKWARDS.

FLOURESCENT LIGHTS

TO REPLACE THE FLOURESCENT LIGHTS IN A WHEEL DEAL:

1. REMOVE THE 2 6-32 NUTS HOLDING THE TOP OF THE GAME.
2. REMOVE THE TOP COVER
3. REMOVE THE 2 6-32 NUTS HOLDING ON THE FRONT MARQUEE GLASS
4. REINSTALL NEW BULBS. 110VOLT, 100WATT SPIRAL FLOURESCENT.
5. REASSEMBLE

NOTE: THE PLAYFIELD BULB IS 110 VOLT, 60 WATT FLOOD LAMP.

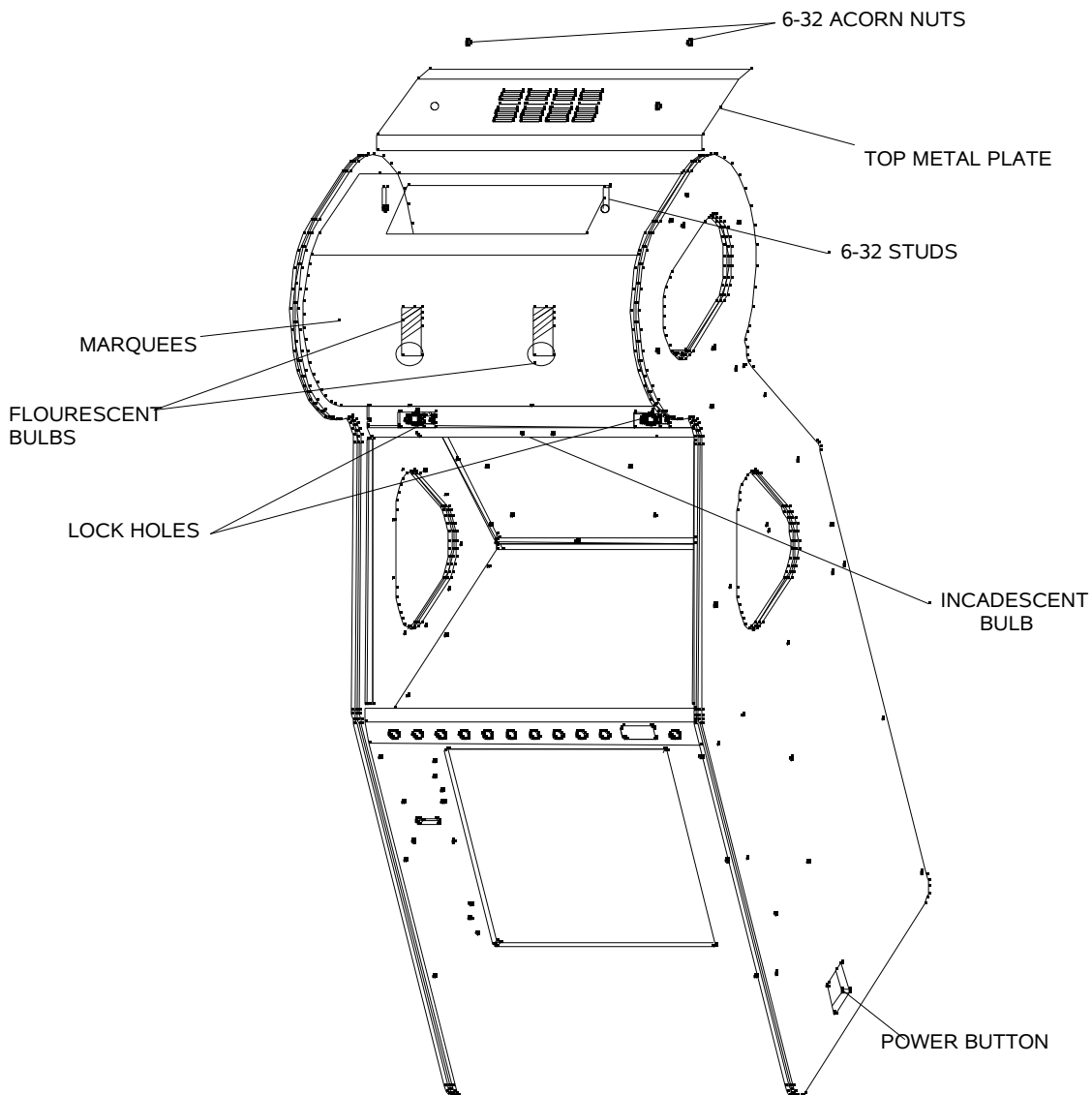

TROUBLESHOOTING GUIDE

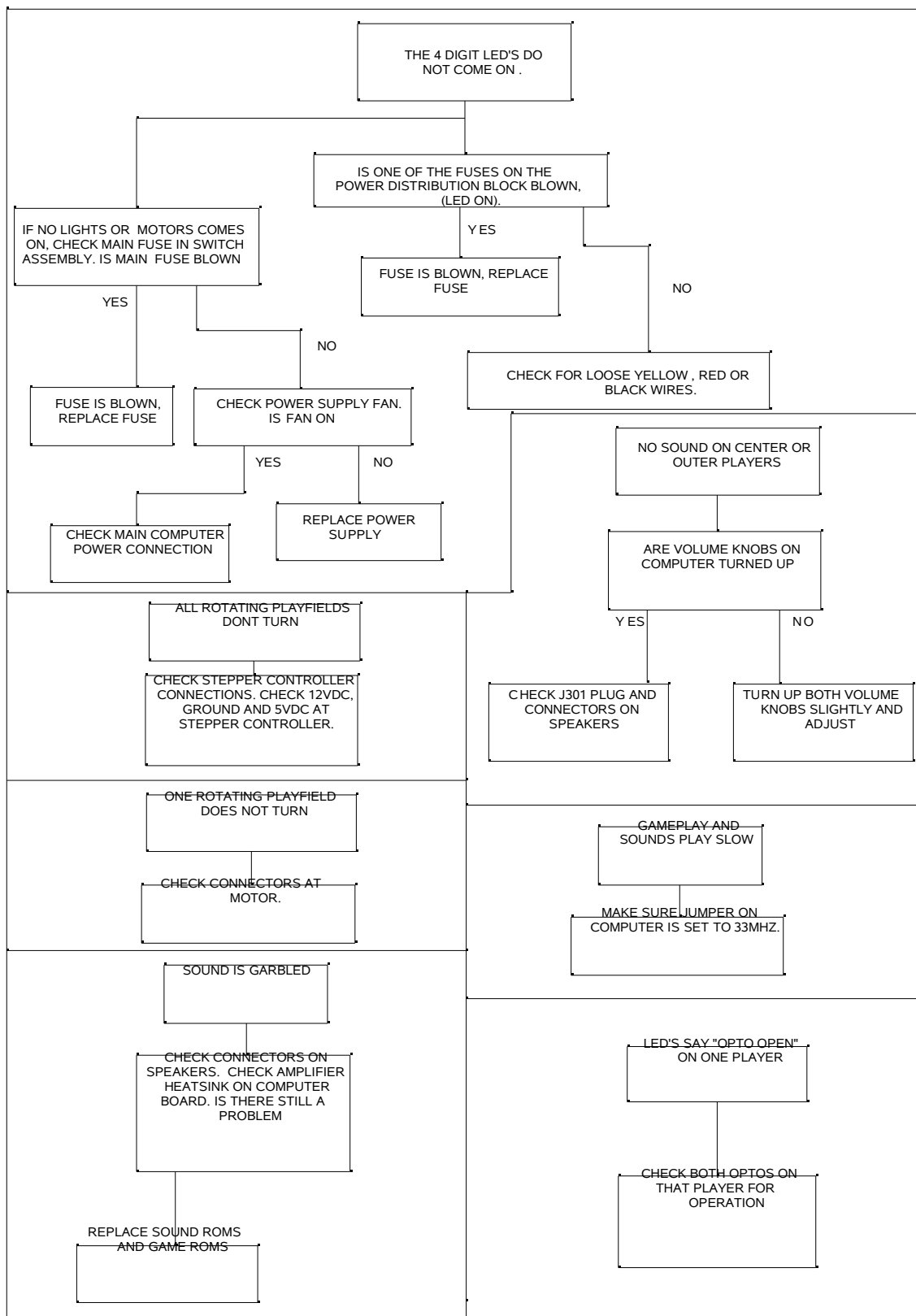

TROUBLESHOOTING GUIDE CONT' D

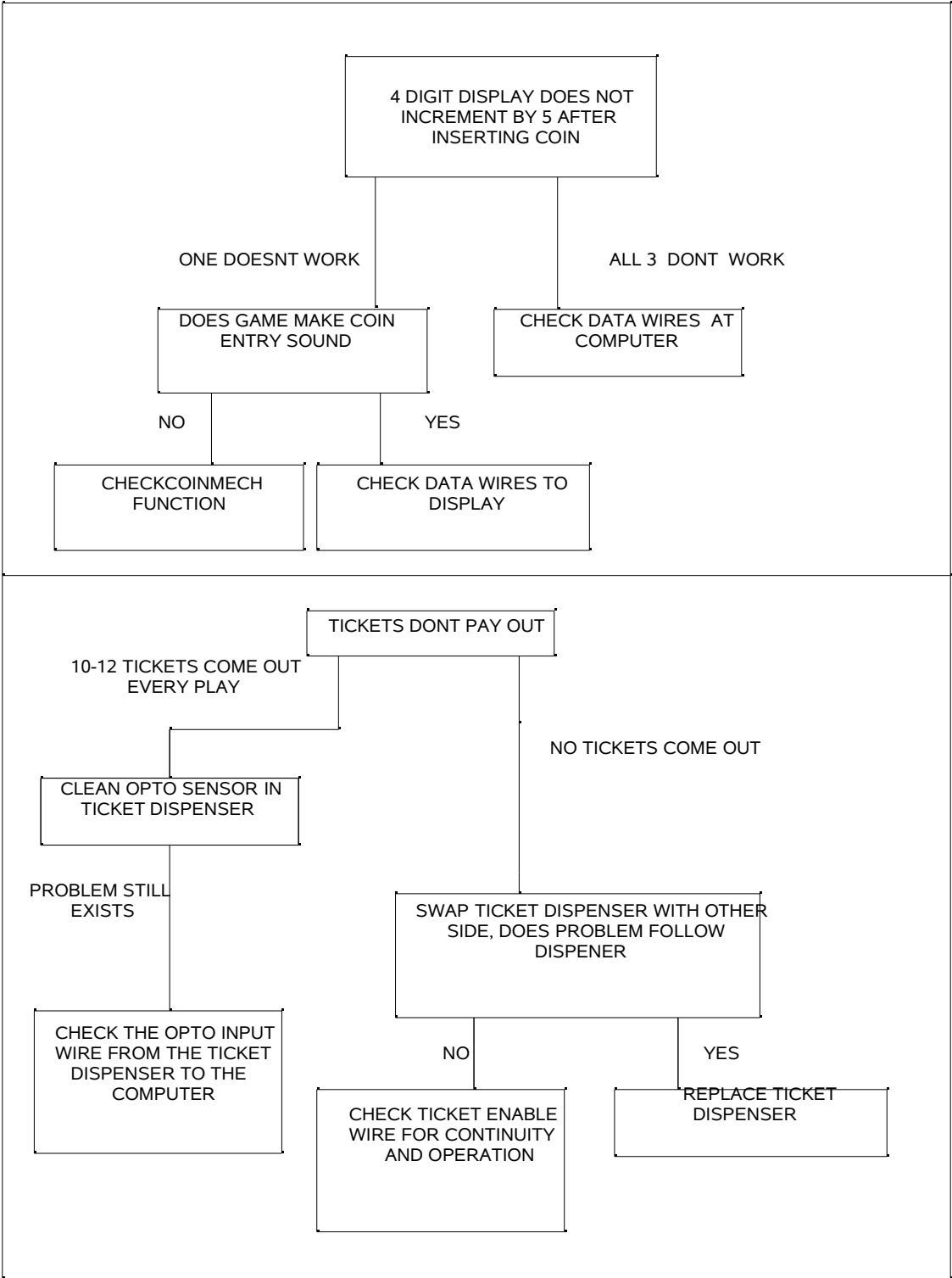

CPU BOARD BLOCK DIAGRAM

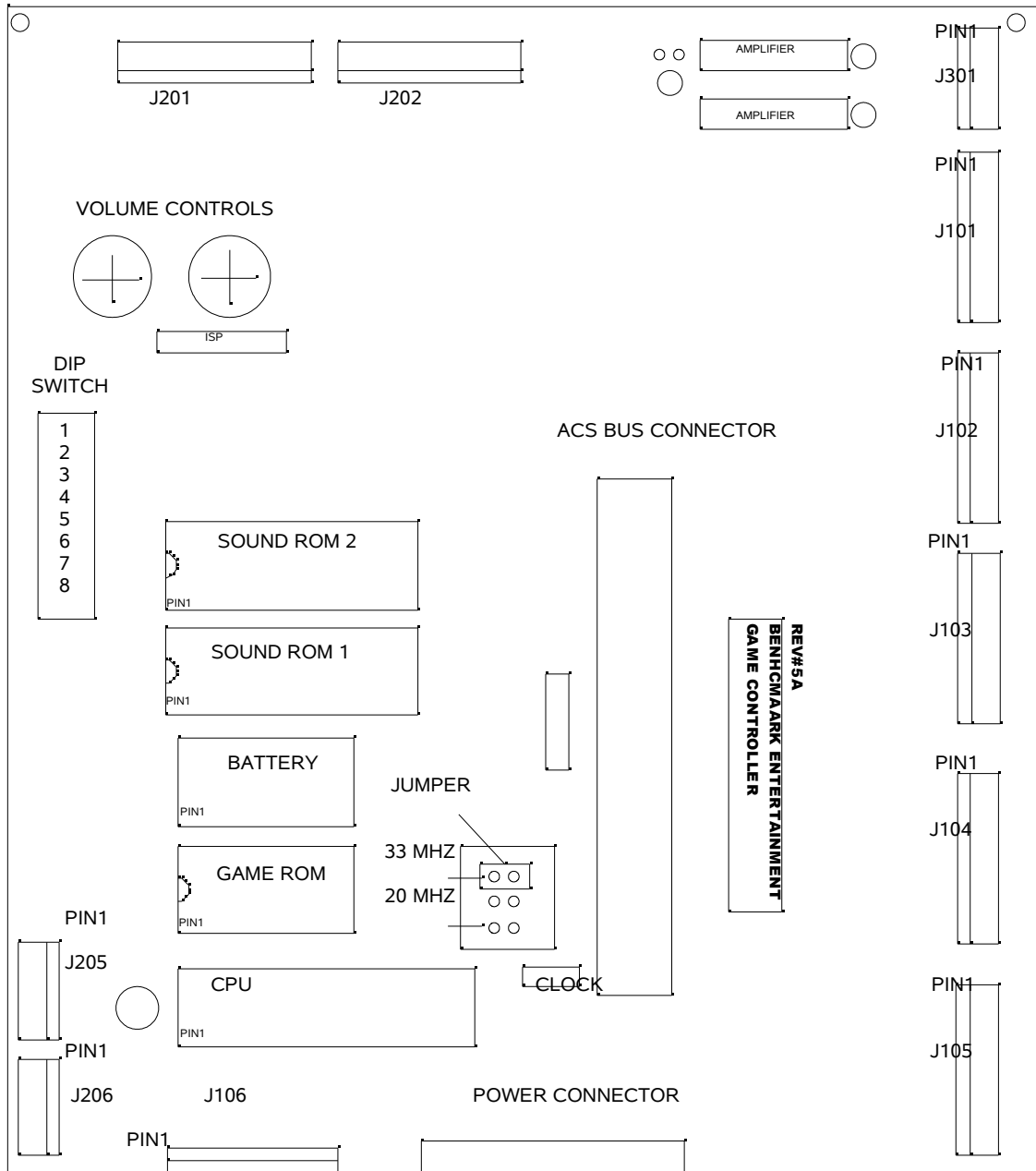

NOTE: THERE HAVE BEEN 5 REVISIONS OF THE BENCHMARK CONTROLLER, ONLY REV 5 WILL WORK IN WHEEL DEAL COMPANY. THE JUMPER ON THE MHZ MUST BE SET AT 33 MHZ AS SHOWN ON THE PICTURE ABOVE. BE CAREFULL WITH THE CONNECTORS NOT TO PUT THEM ONE PIN OFF OR BEND ANY OF THE PINS.

EXPANSION BOARD

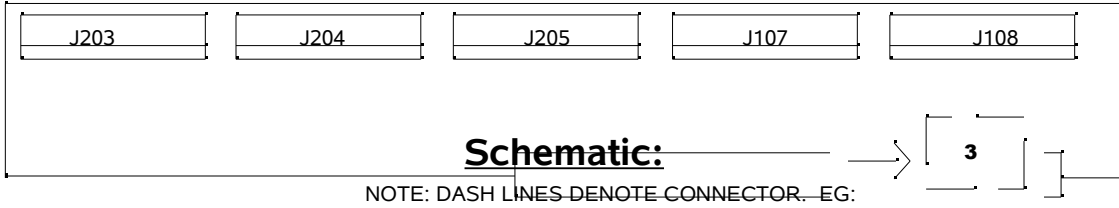

ROTATING PLAYFIELD MOTOR PLAYER 1

STEPPER CONTROLLER

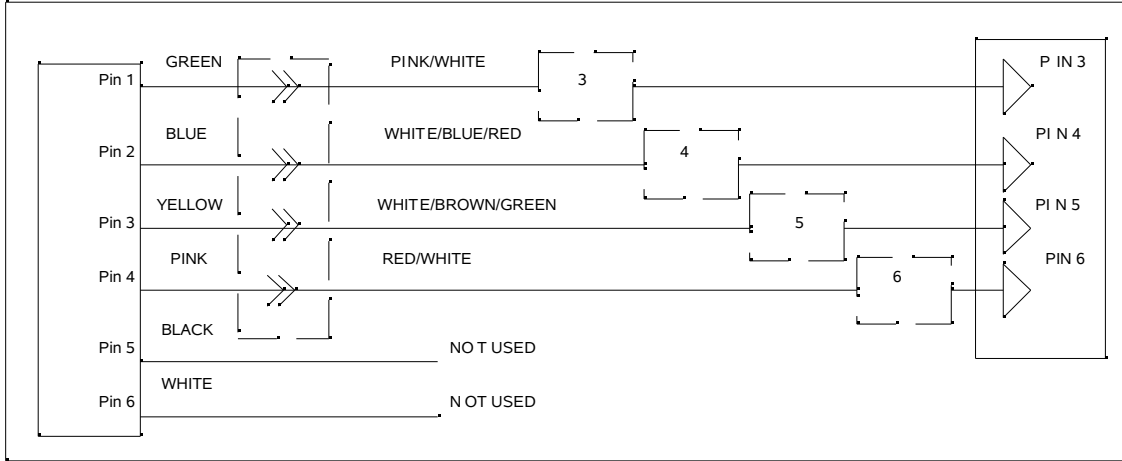

ROTATING PLAYFIELD MOTOR PLAYER 2

STEPPER CONTROLLER

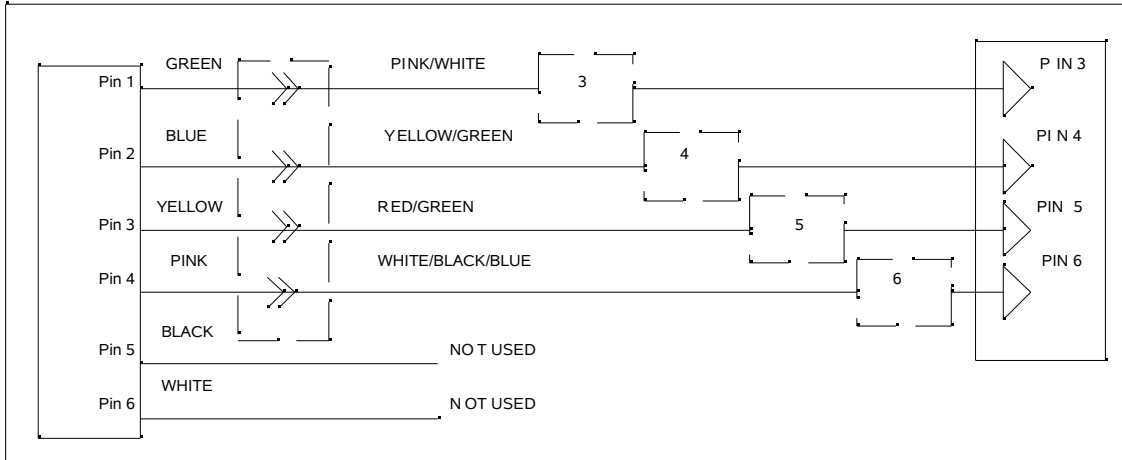

ROTATING PLAYFIELD MOTOR PLAYER 3

STEPPER CONTROLLER

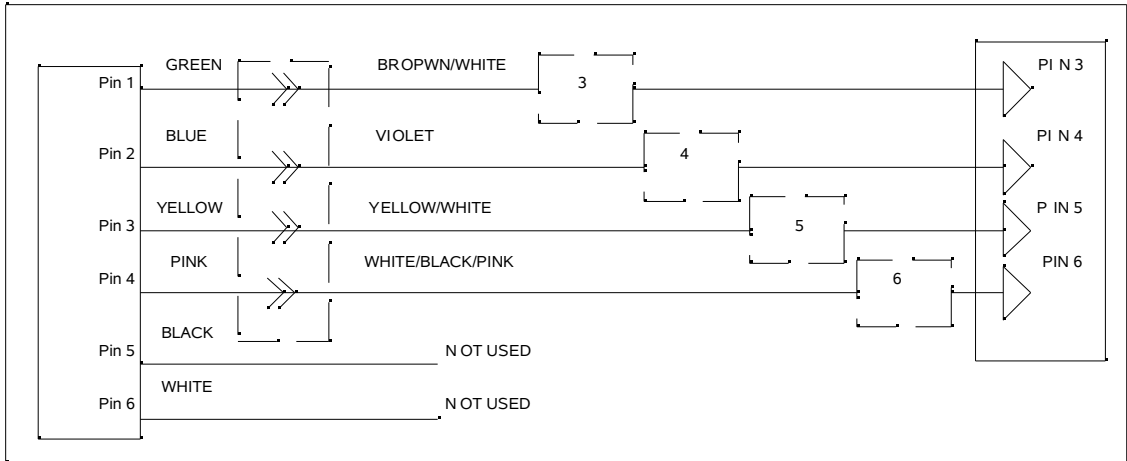

Schematic:

4 DIGIT JACKPOT DISPLAY PLAYER 1

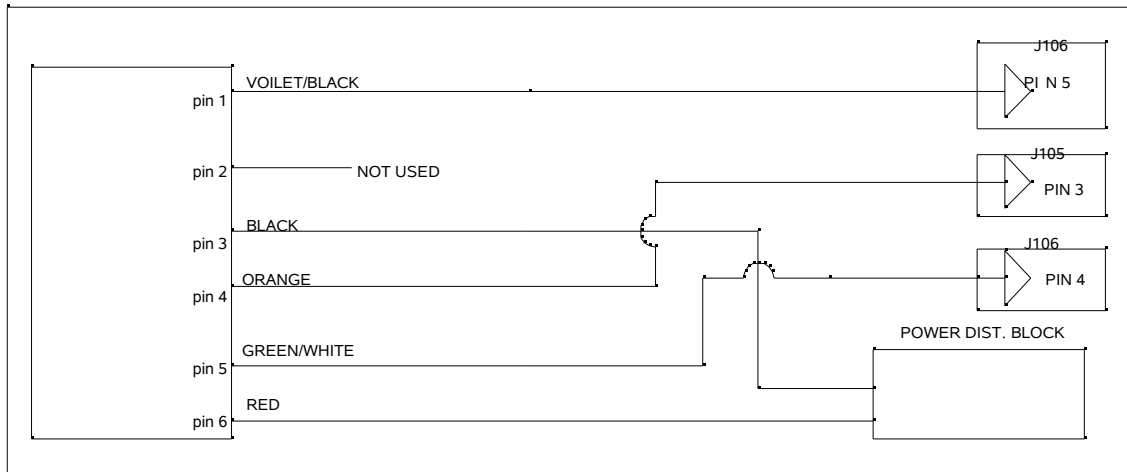

4 DIGIT TICKETS OWNED DISPLAY PLAYER 1

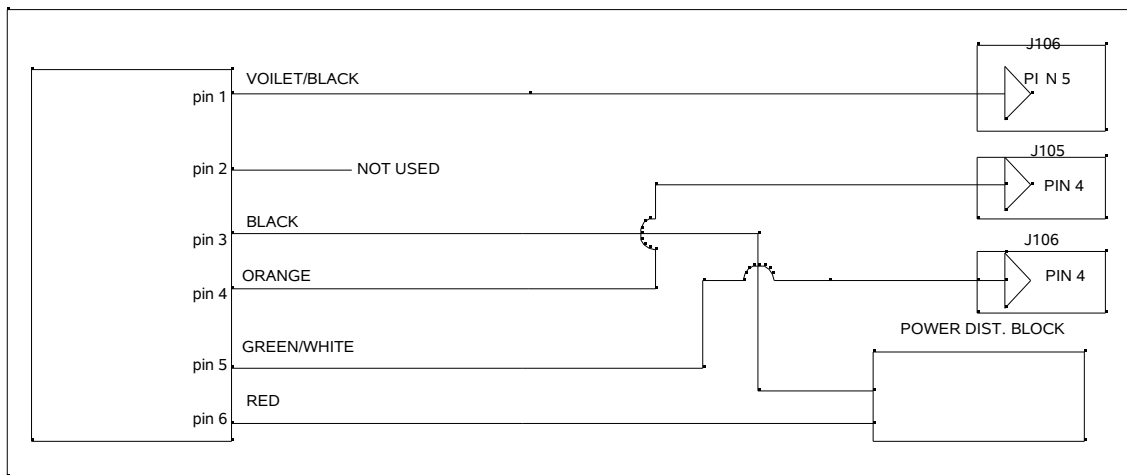

4 DIGIT JACKPOT DISPLAY PLAYER 2

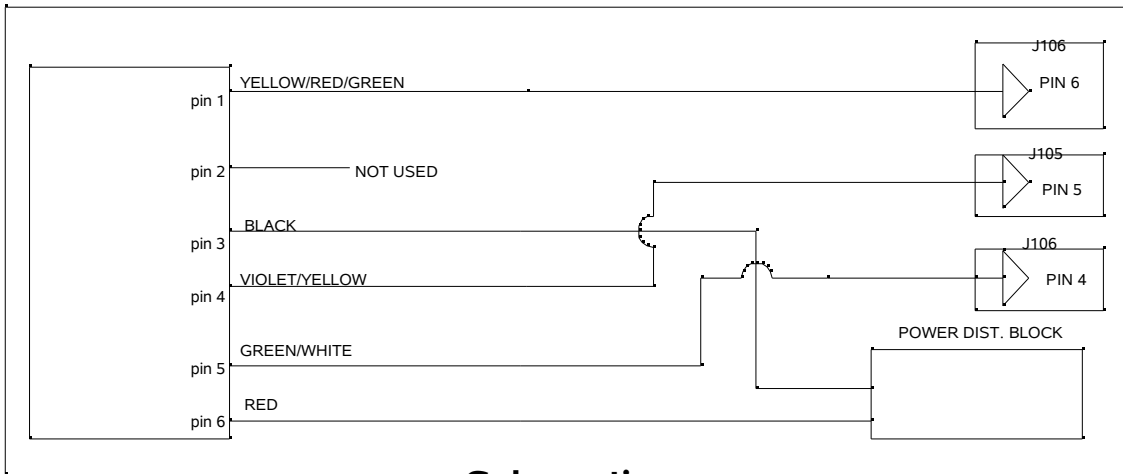

Schematic:

4 DIGIT TICKETS OWNED DISPLAY PLAYER 2

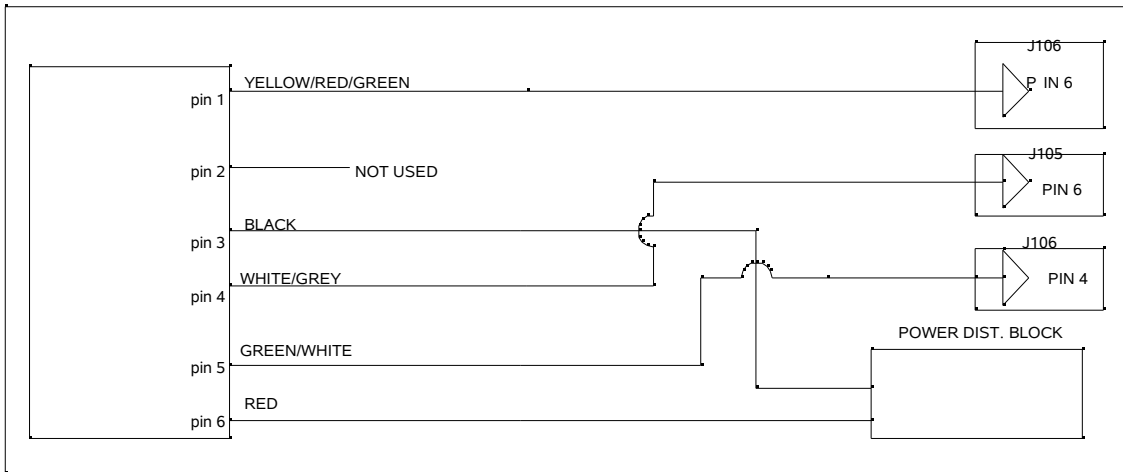

4 DIGITAL JACKPOT DISPLAY PLAYER 3

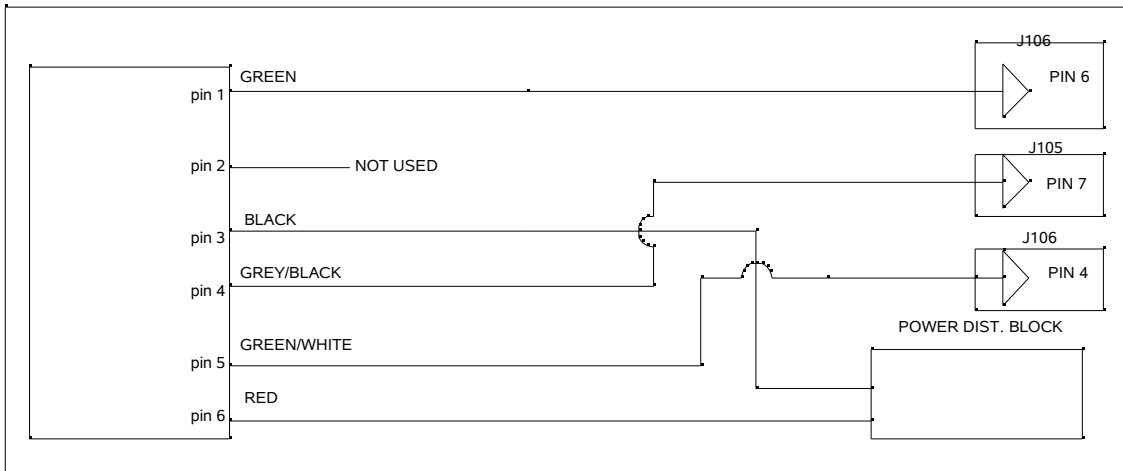

4 DIGIT TICKETS OWNED DISPLAY PLAYER 3

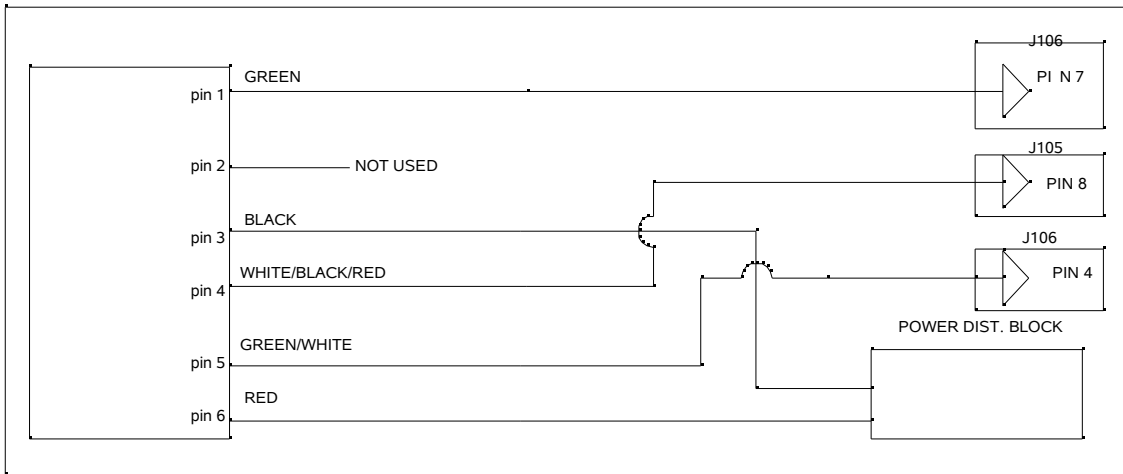

Schematic:

PLAYER 1 HOME OPTO SENSORS

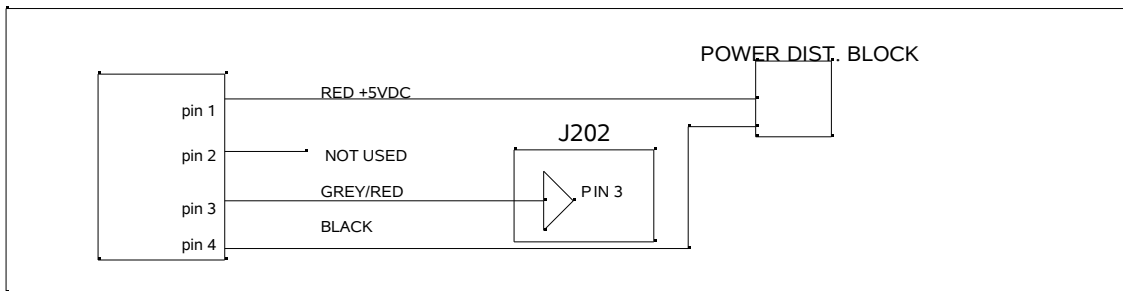

PLAYER 1 COIN OPTO SENSORS

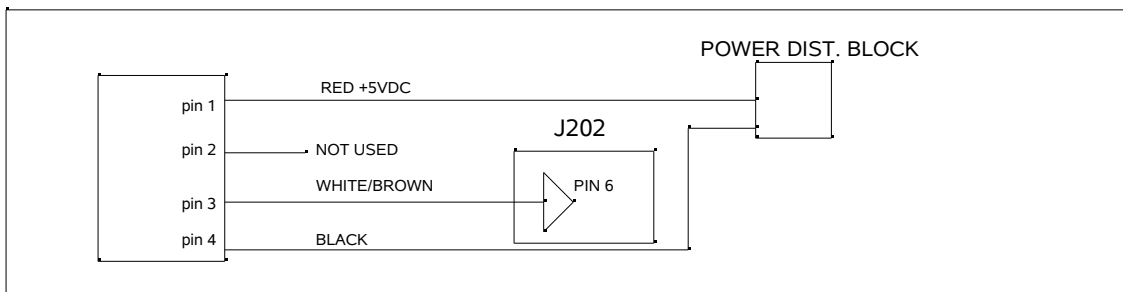

PLAYER 2 HOME OPTO SENSORS

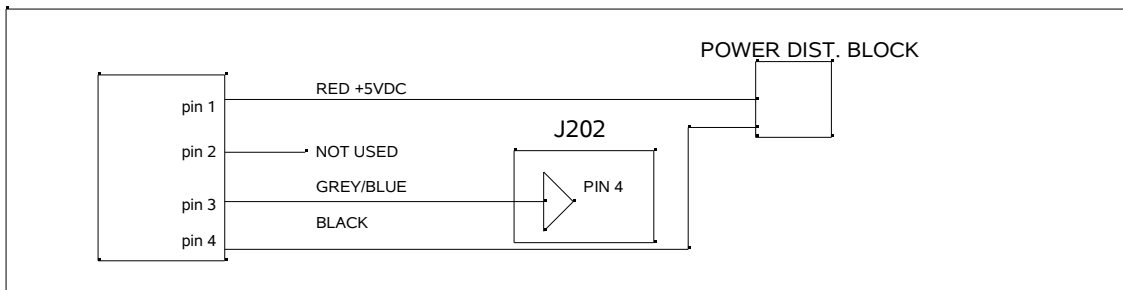

PLAYER 2 COIN OPTO SENSORS

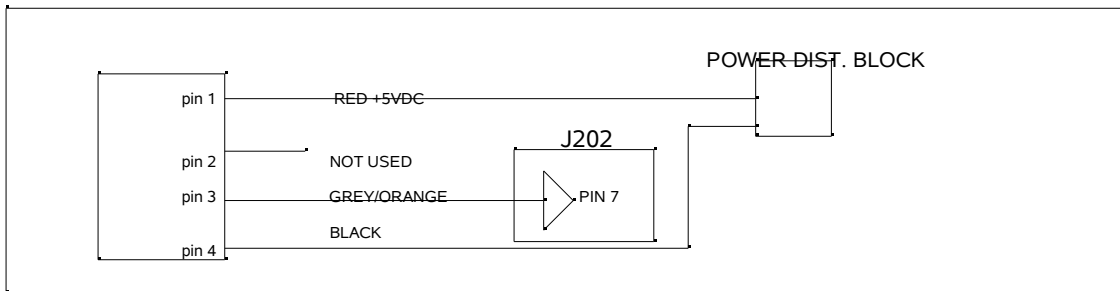

Schematic:

PLAYER 3 HOME OPTO SENSORS

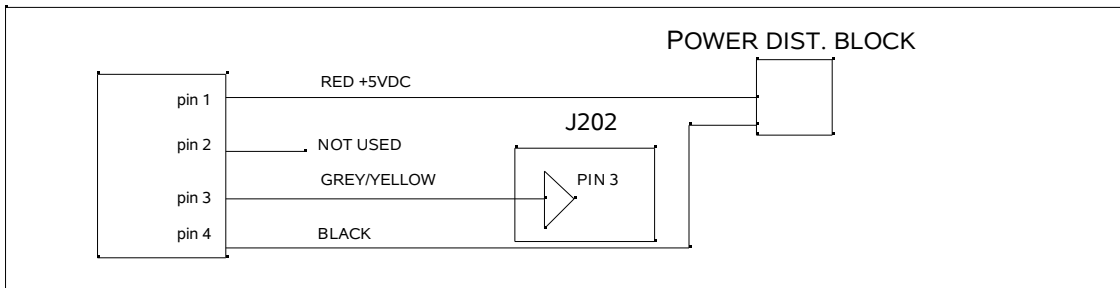

PLAYER 3 COIN OPTO SENSORS

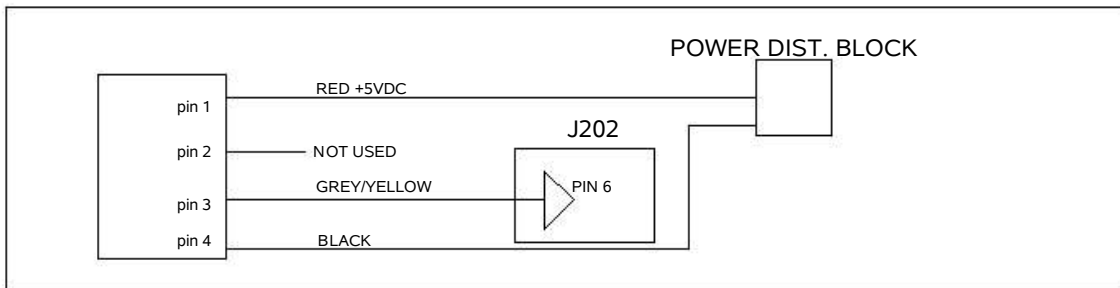

Schematic:

STEPPER CONTROLLER

NOTE: DASH LINES DENOTE CONNECTOR. EG: →

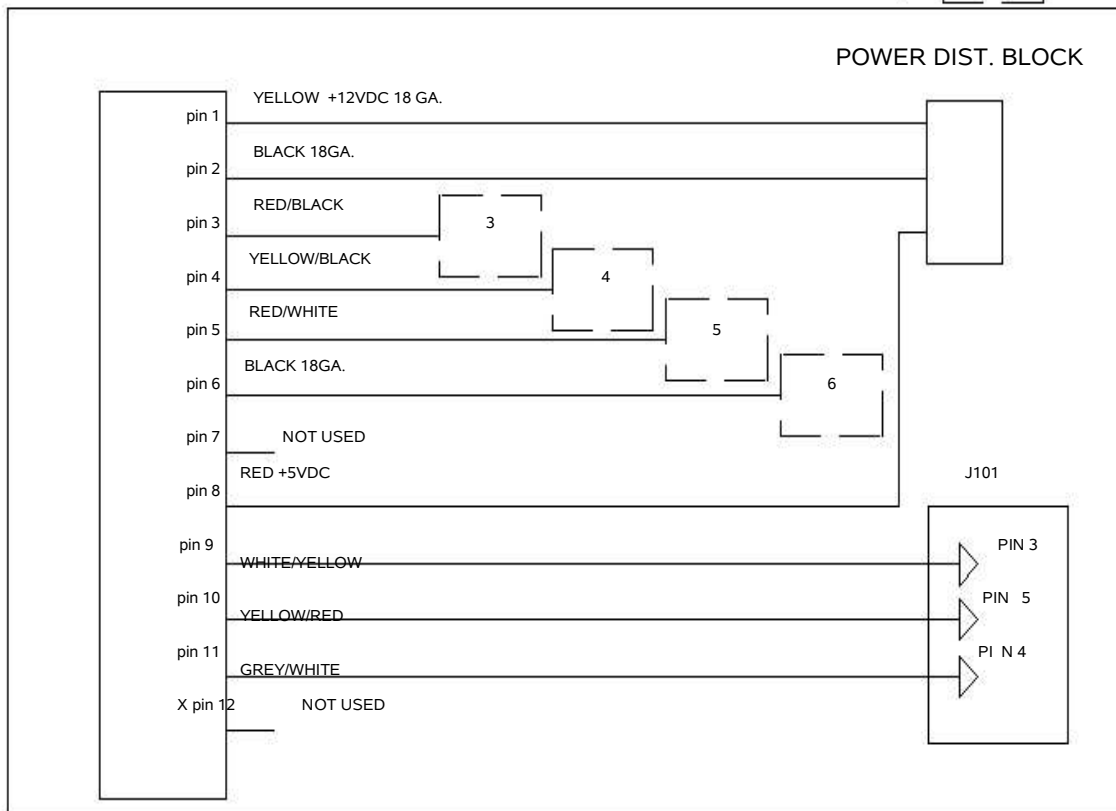
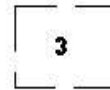

Schematic:

NOTE: REPLACE FLOURESCENT BULBS WITH 100 WATT SPIRAL FLOURESCENT BULBS ONLY. REPLACE INCANDESCENT BULBS WITH 60 WATT FLOOD BULBS.

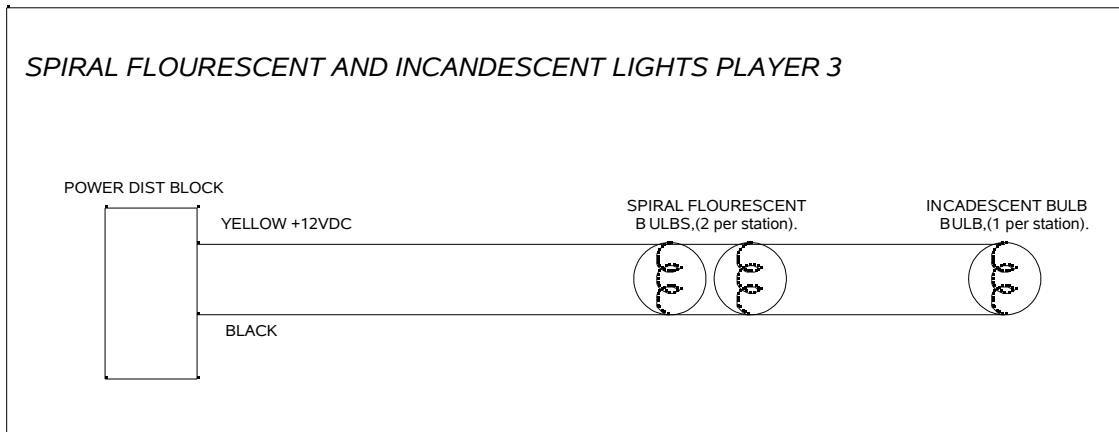
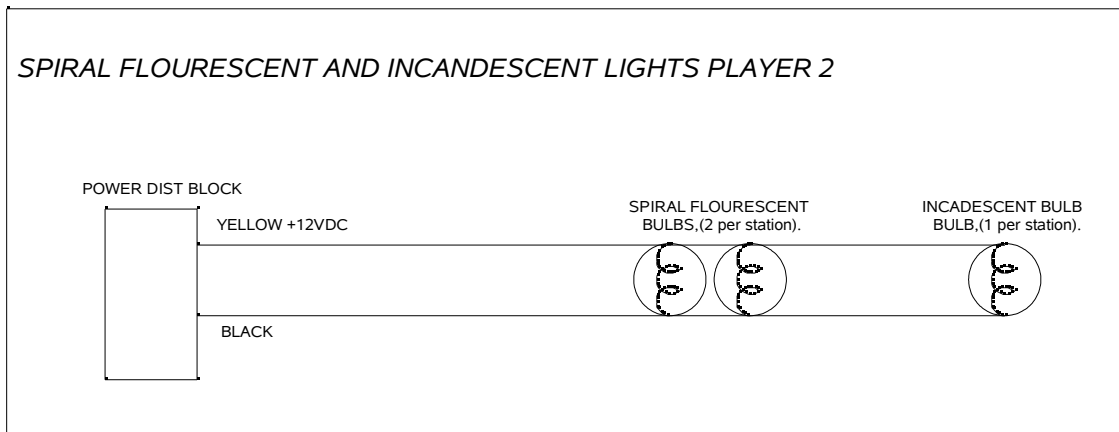
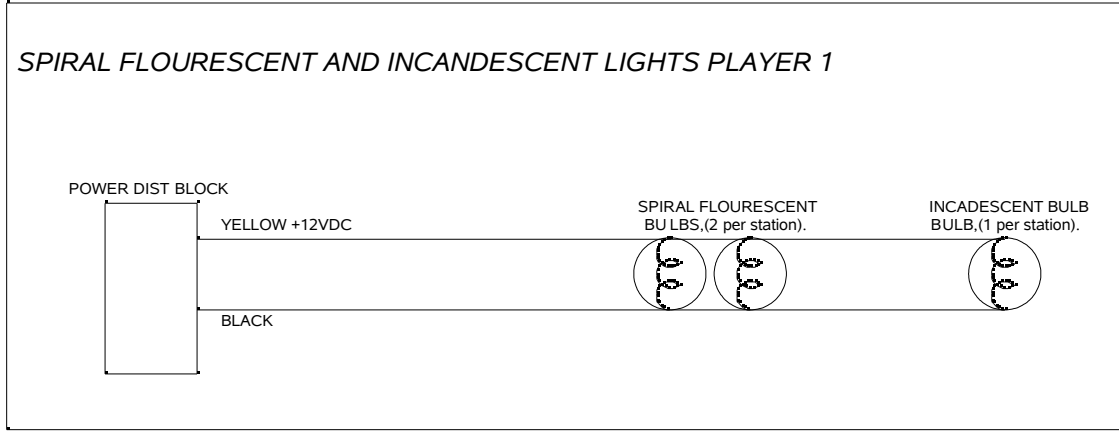

Schematic:

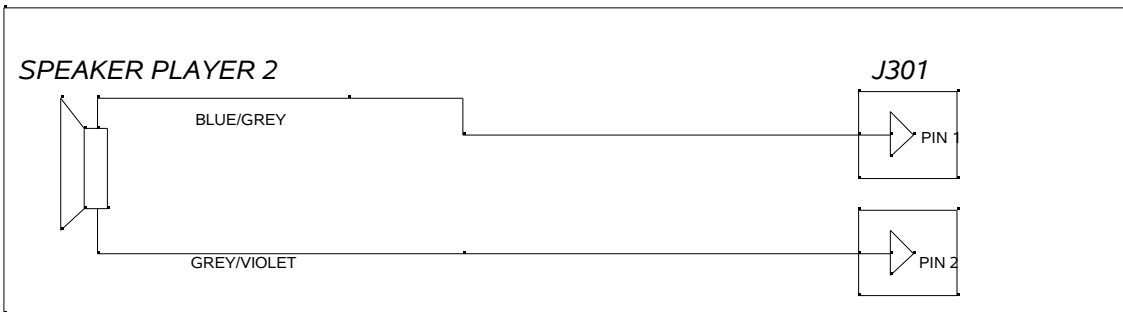
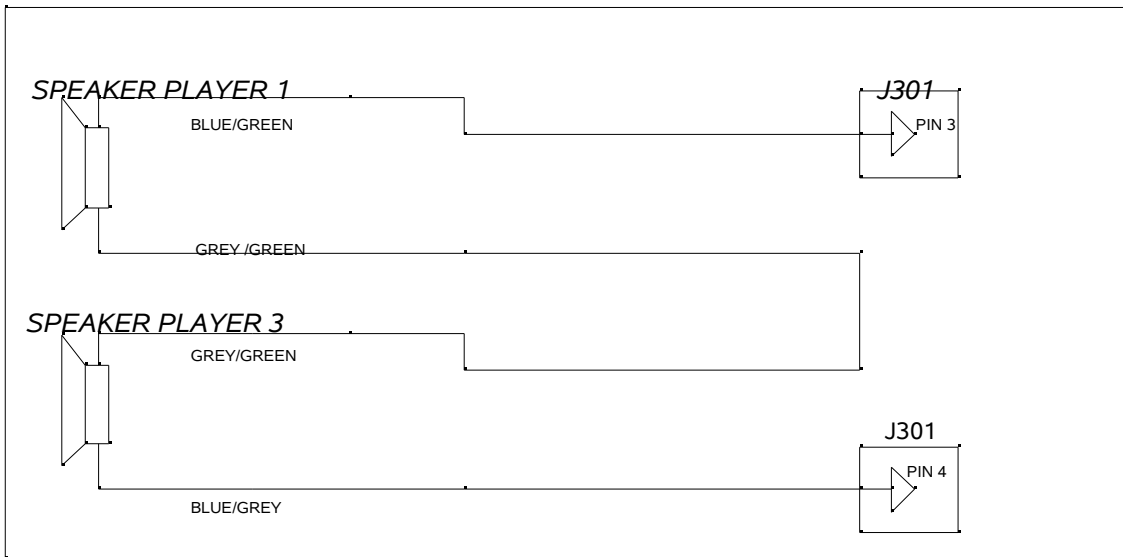

COUNTERS

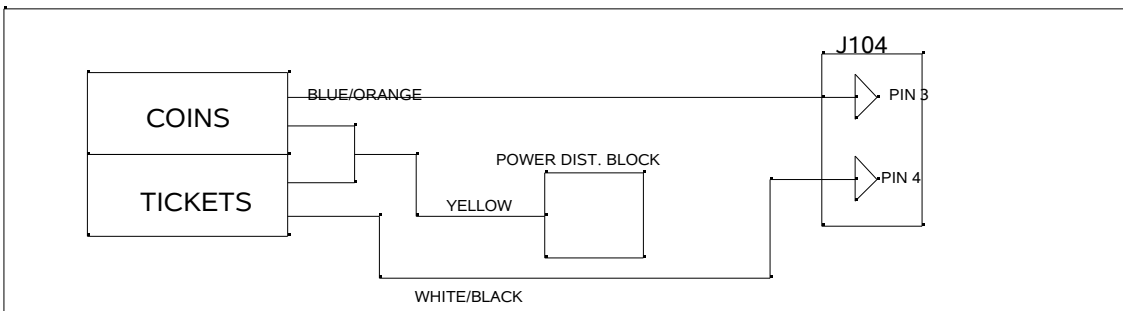

Schematic:

PLAYER 1 TICKET DISPENSER

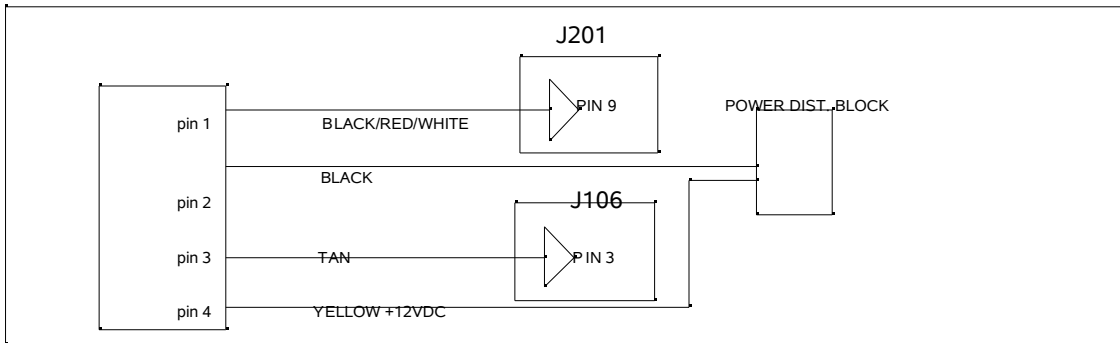

PLAYER 2 TICKET DISPENSER

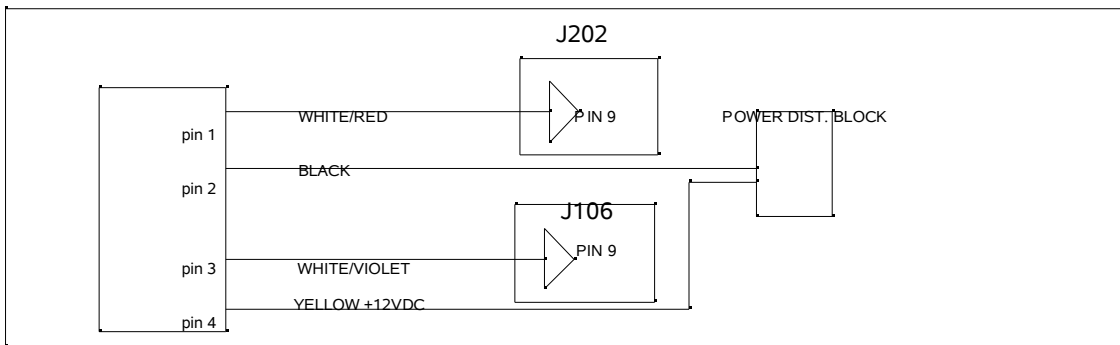

PLAYER 3 TICKET DISPENSER

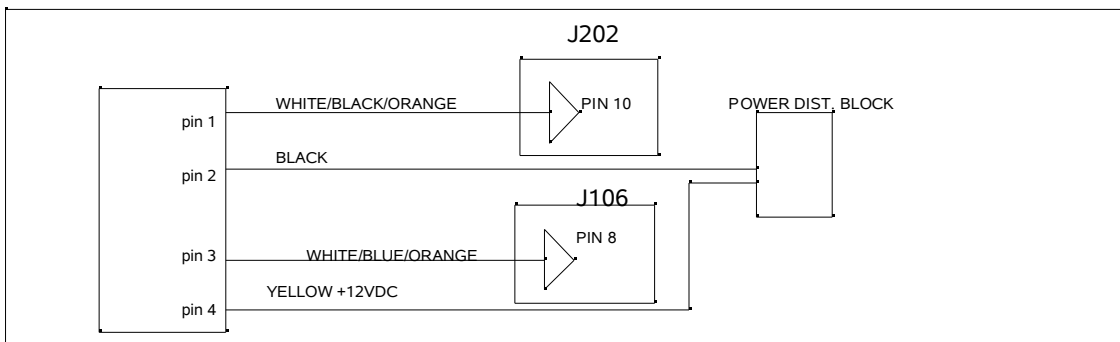

LOW TICKET LIGHTS

