



TOWER OF TICKETS



MANUFACTURED WITH PERMISSION
BY BAY TEK GAMES



FACTORY CONTACT INFORMATION



BAY TEK GAMES INC.
Pulaski Industrial Park
1077 East. Glenbrook Drive
Pulaski, WI 54162 USA



TOWER OF TICKETS IS AN ELAUT
GAME, BUILT WITH PERMISSION
BY BAY TEK GAMES.

JOIN OUR SERVICE FIRST NETWORK!

This free service is intended to keep you up to date on the latest game information, early notification of parts specials, pertinent technical bulletins, updates on retro fit parts, software upgrades, and much more.

Log on to: www.baytekgames.com/part then click on the Parts N' Service tab.

SALES

P: 920.822.3951

F: 920.822.8936

E: sales@baytekgames.com

PARTS

P: 920.822.3951 X 1101

F: 920.822.1496

E: parts@baytekgames.com

SERVICE

P: 920.822.3951 X 1102

F: 920.822.1496

E: service@baytekgames.com

MON - FRI
8 AM - 5 PM C.S.T.

All games are proudly manufactured at our factory in Pulaski, Wisconsin, USA

TABLE OF CONTENTS

FACTORY CONTACT INFORMATION	2
WELCOME TO: Tower of Tickets	4
HOW TO PLAY	5
SPECIFICATIONS	6
SOFTWARE VERSION	6
SAFETY PRECAUTIONS	6
GAME SETTINGS	7
SET UP GUIDE	8-10
TICKET TOWER ROLL KITS	11
MAINBOARD PINOUT & WIRING	12-14
DOOR BOARD PINOUT & WIRING	15-17
TROUBLESHOOTING GUIDE	18-21
BILL ACCEPTOR DIAGNOSTICS	22
HOW TO: ACCESS CIRCUIT BOARDS	23
HOW TO: ACCESS PLAYFIELD	23
HOW TO: ACCESS MOTORS & CABLES	24
DECAL IDENTIFICATION	25
MAINTENANCE LOG	26
TECHNICAL SUPPORT	27
WARRANTY	28

WELCOME TO: Tower of Tickets

Congratulations on your Tower of Tickets purchase!

Tickets are king in the gameroom, and Tower of Tickets provides a big draw with it's visually exciting ticket cones and bright lighting. The four-player unit allows cash to be coming in from virtually every angle!

Please take a moment to read through this manual and be sure to contact our factory if you have any questions, or would like some more information.

Thank you for your purchase! Your business is important to us and we hope you enjoy this game as much as we do!

Your Friends at Bay Tek Games



GAME INSPECTION

Inspect the game for any damaged, loose, or missing parts.

If damage is found, please contact your freight carrier first.

Then, contact Bay Tek Games' Service Department at 920.822.3951 or e-mail them at service@baytekgames.com for further assistance.

HOW TO PLAY

Choose one of the four brightly-colored player stations.



Simply press the button to activate the swinging arm.



Time your move just right to push a Tower of Tickets off the rotating platform!



Grab your tickets and redeem them for prizes!















GAME SPECIFICATIONS

WEIGHT	
NET WEIGHT	480 lbs.
SHIP WEIGHT	540 lbs.
DIMENSIONS	
WIDTH	55"
DEPTH	55"
HEIGHT	85"
OPERATING TEMPERATURE	
FAHRENHEIT	80-100
CELSIUS	26.7-37.8

POWER REQUIREMENTS			
INPUT VOLTAGE RANGE	100 to 120 VAC	/	220 to 240 VAC
INPUT FREQUENCY RANGE	50 HZ	/	60 HZ
MAXIMUM CURRENT			
5.5 AMPS @ 115 VAC			
3 AMPS @ 230 VAC			

SAFETY PRECAUTIONS

	NOTICE	
<p>Modifications to the mechanical, electrical and structural components of this game may void its compliance certifications.</p> <p>This appliance is suitable for INDOOR, DRY locations only.</p>		
	DANGER	
<p>DO NOT perform repairs or maintenance on this game with the power ON. Unplug the unit from the wall outlet or shut off the power strip located inside the cabinet.</p>		
	WARNING	
<p>Use of flammable substances can cause sever burns or serious injury. Always use NON-FLAMMABLE solvents for cleaning. DO NOT use gasoline kerosene or thinners.</p>		
	CAUTION	
<p>Lifting heavy objects can cause back, neck or other injuries. Be sure adequate lifting and moving devices are available when unloading, unpacking and moving this game.</p>		
	ATTENTION	
<p>Be sure the electrical power matches the game requirements. See the serial number located on the back of the game cabinet. Always plug into a grounded circuit. If the supply cord is damaged, it must be replaced by an approved cord or assembly provided by the manufacturer. A shielded power cable must be used for the game to retain EU/EMC compliance.</p>		
	IN CASE OF EMERGENCY	
<p>UNPLUG THE POWER CORD. The power cord must be accessible at all times in case of an emergency.</p>		

GAME SETTINGS

The volume adjust knobs and dip switch bank are located on the mainboard, inside the RED door.

*factory default settings are highlighted below

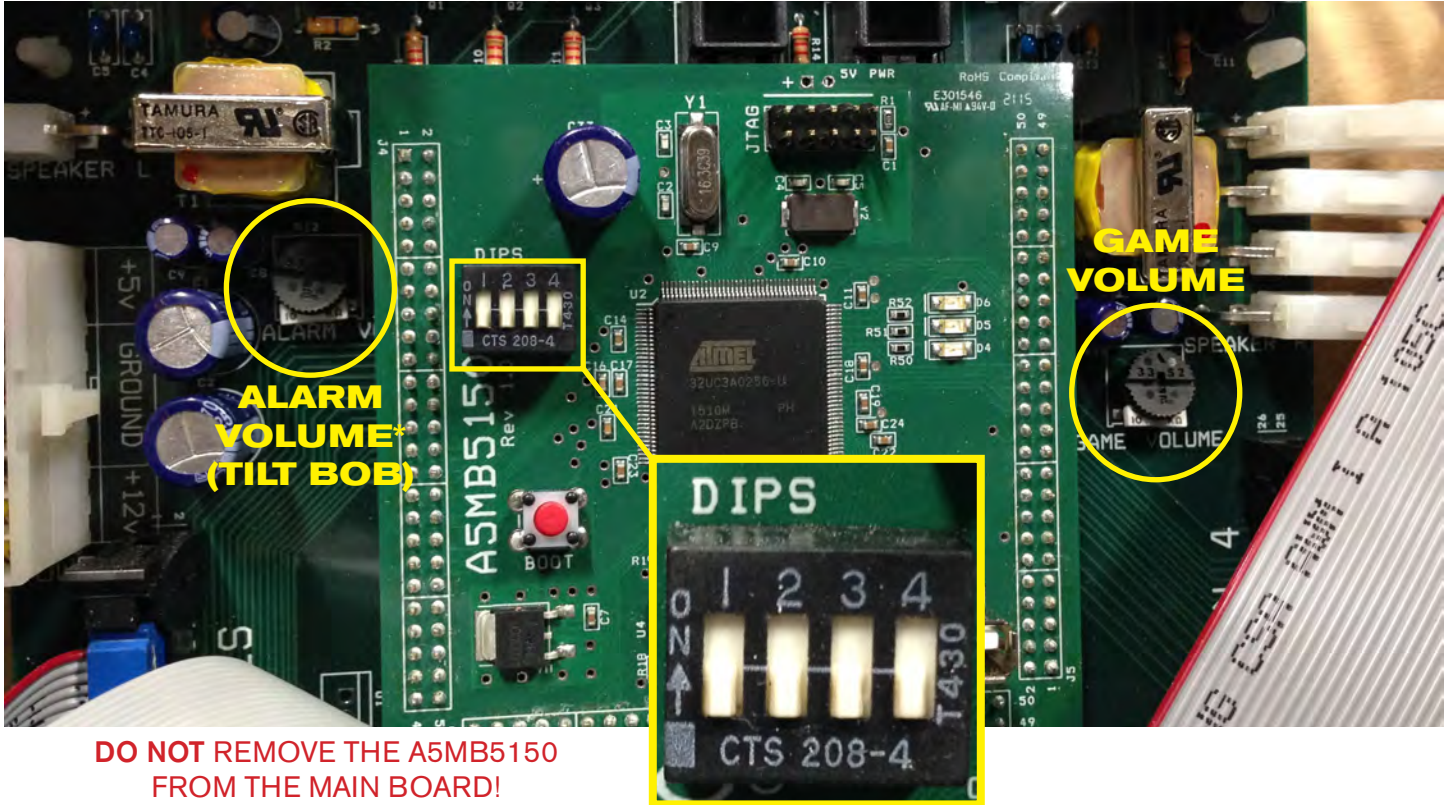

DO NOT REMOVE THE A5MB5150 FROM THE MAIN BOARD!

SWITCH	DESCRIPTION	ON	OFF
1	Credits per Play adjust (see table below)	X	
2			X
3	Game Attract Sounds	X	
4	Store Credits/Tickets Owed (in case of power outage; required for New Jersey)		X

CREDITS PER PLAY	1 (\$.25)		2 (\$.50)		4 (\$1.00)		6 (\$1.50)	
	ON	OFF	ON	OFF	ON	OFF	ON	OFF
DIP 1		X		X	X		X	
DIP 2		X	X			X	X	

*Tower of Tickets is equipped with an anti-cheat tilt bob alarm.

Please ensure your staff is familiar with this alarm, and keep it at a high volume to deter cheating.

QUICK SET UP GUIDE

Place the game near its final location.



Unlock the dome and open; remove and unpackage the four button boxes. *The hardware packet is located in the **red station** cashbox.*



Attach the four button boxes to the sides of the cabinet using included washers and lock nuts. *Be sure to match the colors of the boxes to the colors of the player stations.*



Plug in the buttons, grounds and speakers as shown. *Insert the button switch into the button housing and turn, locking into place.*

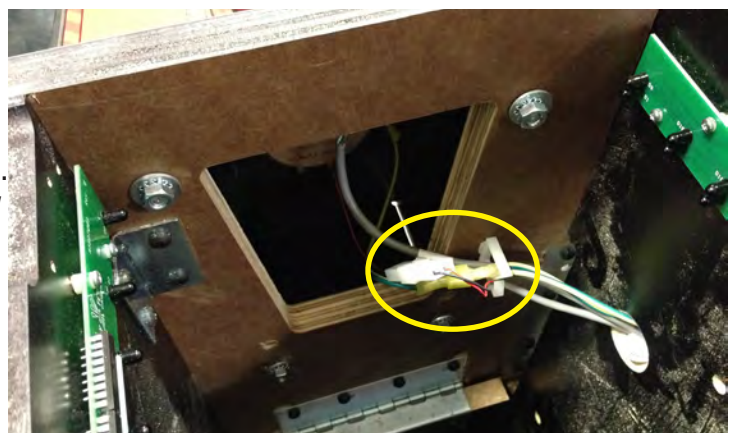

QUICK SET UP GUIDE

Remove the plastic top of the red beacon (found inside the dome) by turning it counter-clockwise.



Plug in the beacon cable at the top of the marquee and place the beacon so that the red button is aligned with the cut out area (button should NOT be pressed in).

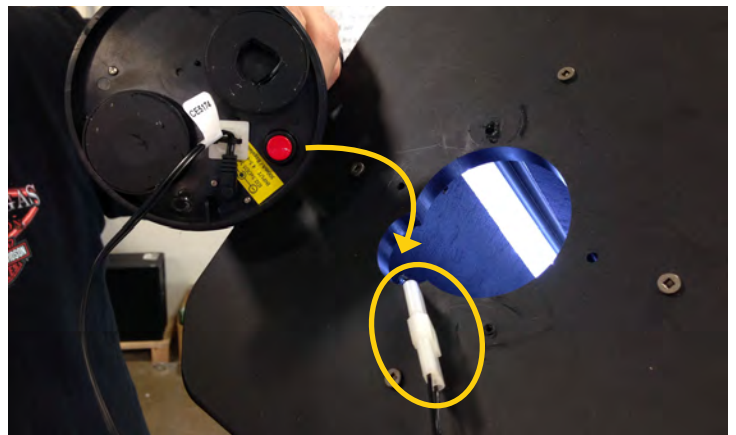

Secure beacon in place with included 1 1/4" bugle screws, using the pilot holes.

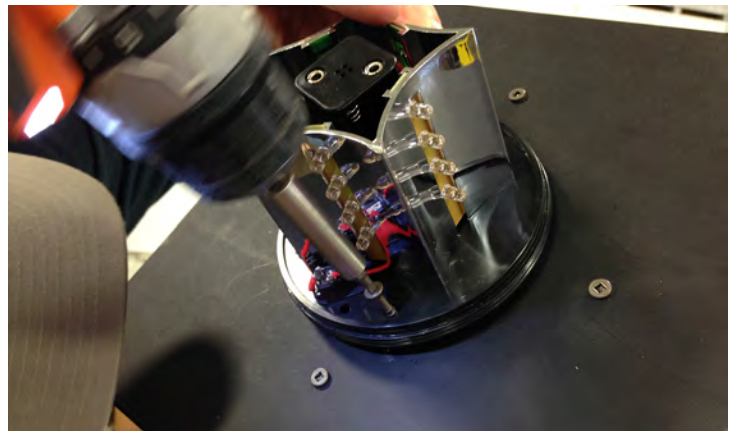

Replace the plastic cover by turning clockwise.



QUICK SET UP GUIDE

Evenly distribute the ticket tower kit across the mirror. See page 11 for information about the ticket tower rolls.



Close the dome and lock.



Plug power cord into a standard electrical outlet and turn the power switch on the outlet strip (inside the red station door) to ON.

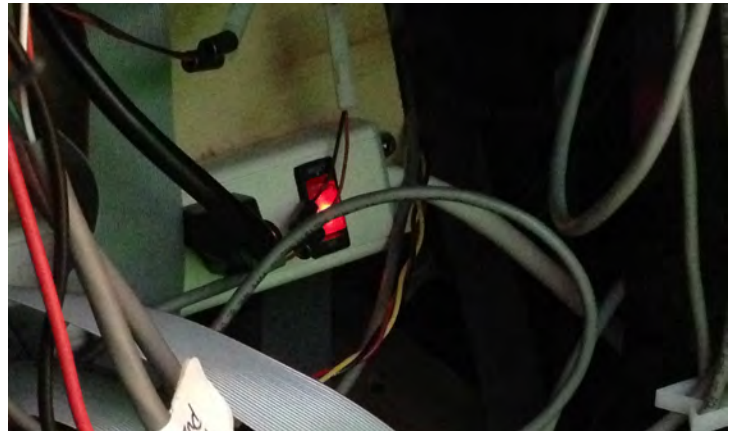

You're ready to play!



TICKET TOWER ROLL KITS

It is important to keep the playfield fully stocked with the ENTIRE KIT of ticket tower rolls to keep revenues high and payout fair. Be sure to have your attendants restock the playfield often.

To order more Ticket Tower rolls, contact:

Bay Tek Games: 920-822-3951

OR

Elaut USA: 732-494-4900

A full Ticket Tower roll kit consists of:

40- 150 POINT ROLLS
2- 300 POINT ROLLS
2- 1000 POINT ROLLS



NOTES:

One set is shipped standard with each game, located inside the orange-station door.

All rolls should be placed on the mirror playfield for normal game operation.

A full set on the playfield attracts players while less rolls deters players. Therefore locations should return any won ticket rolls to the playfield ASAP.

MAINBOARD PINOUT (AACB5150)

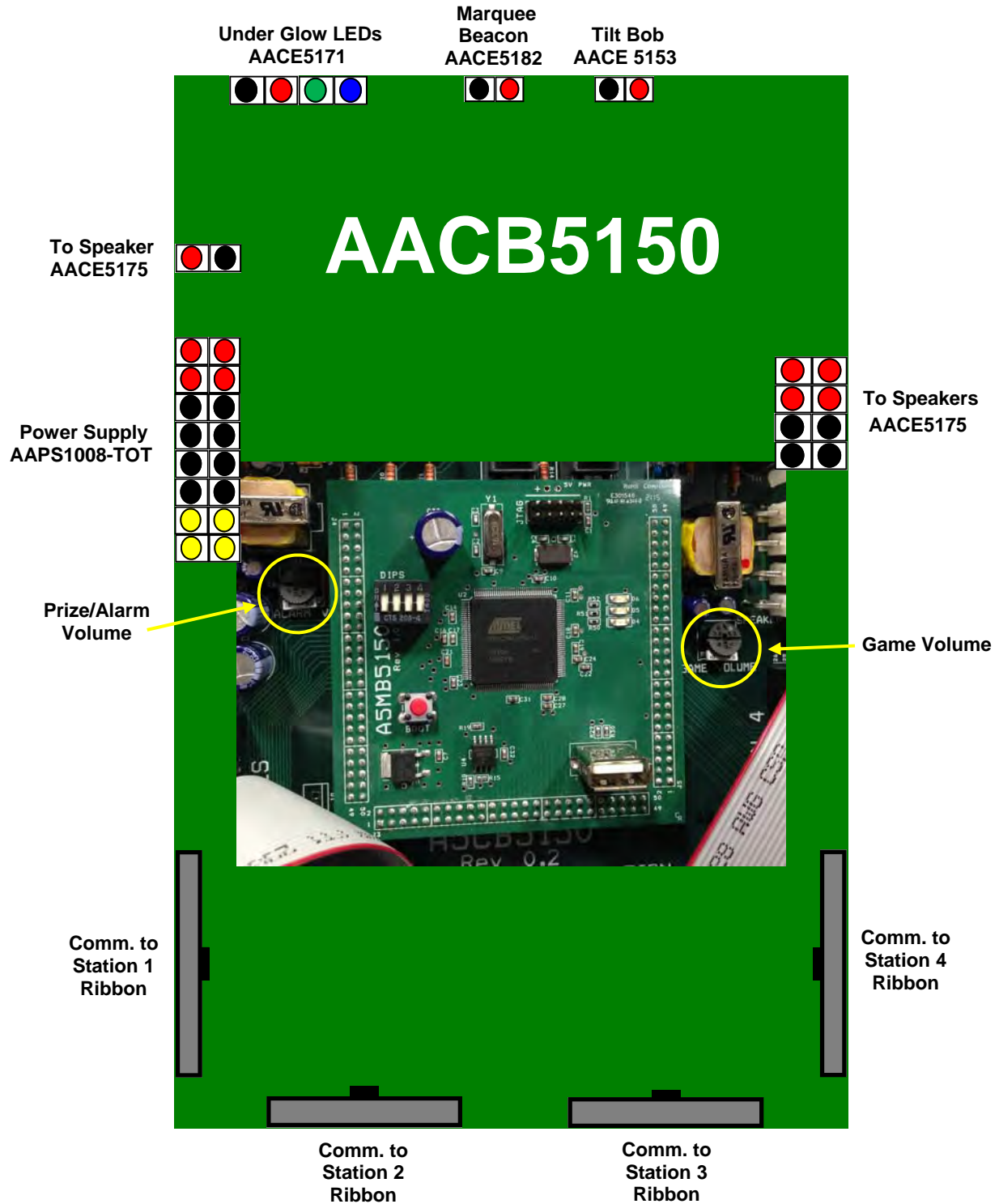

WIRING DIAGRAM: MAINBOARD + MARQUEE POWER

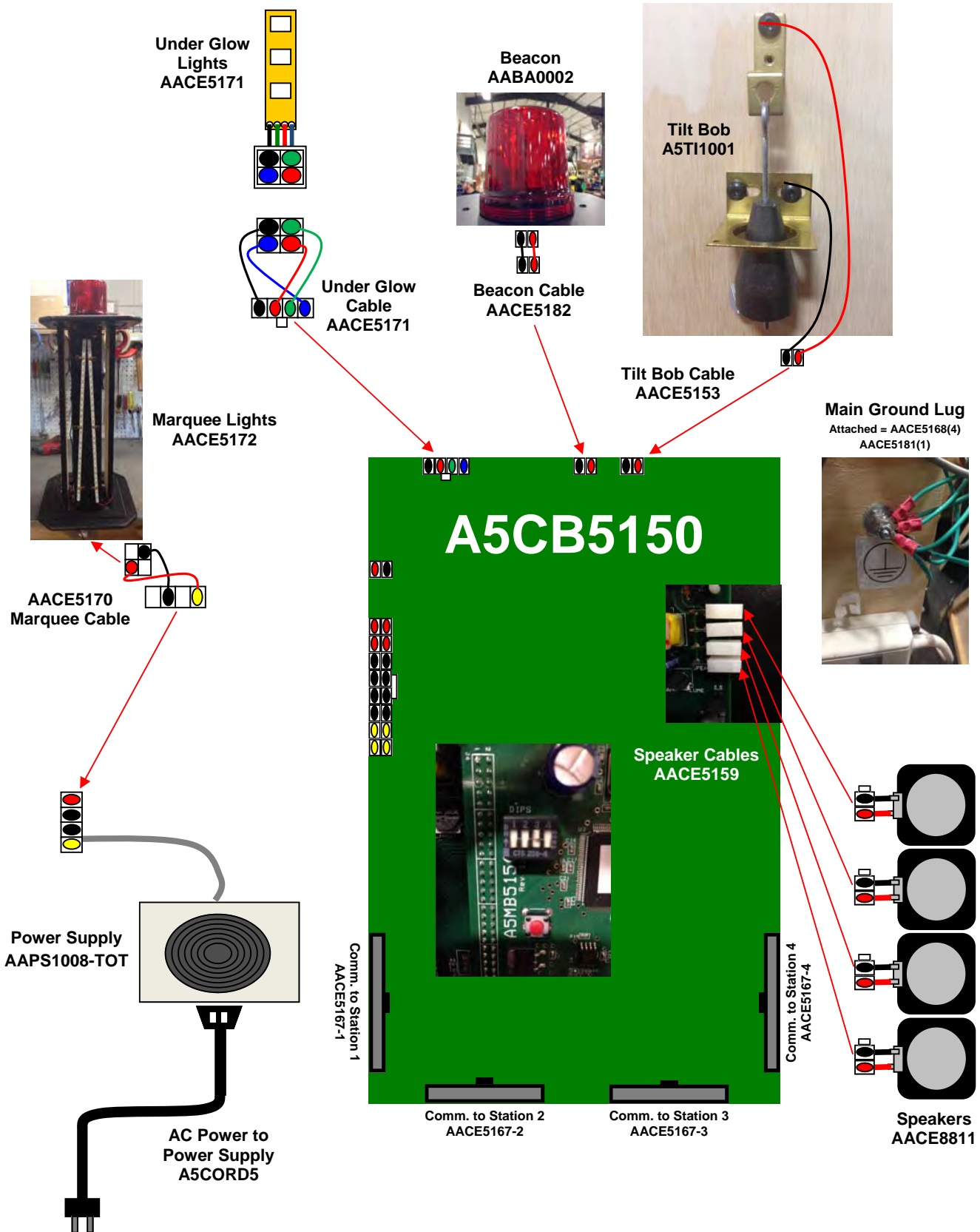

WIRING DIAGRAM: POWER IN + MARQUEE SPEAKER

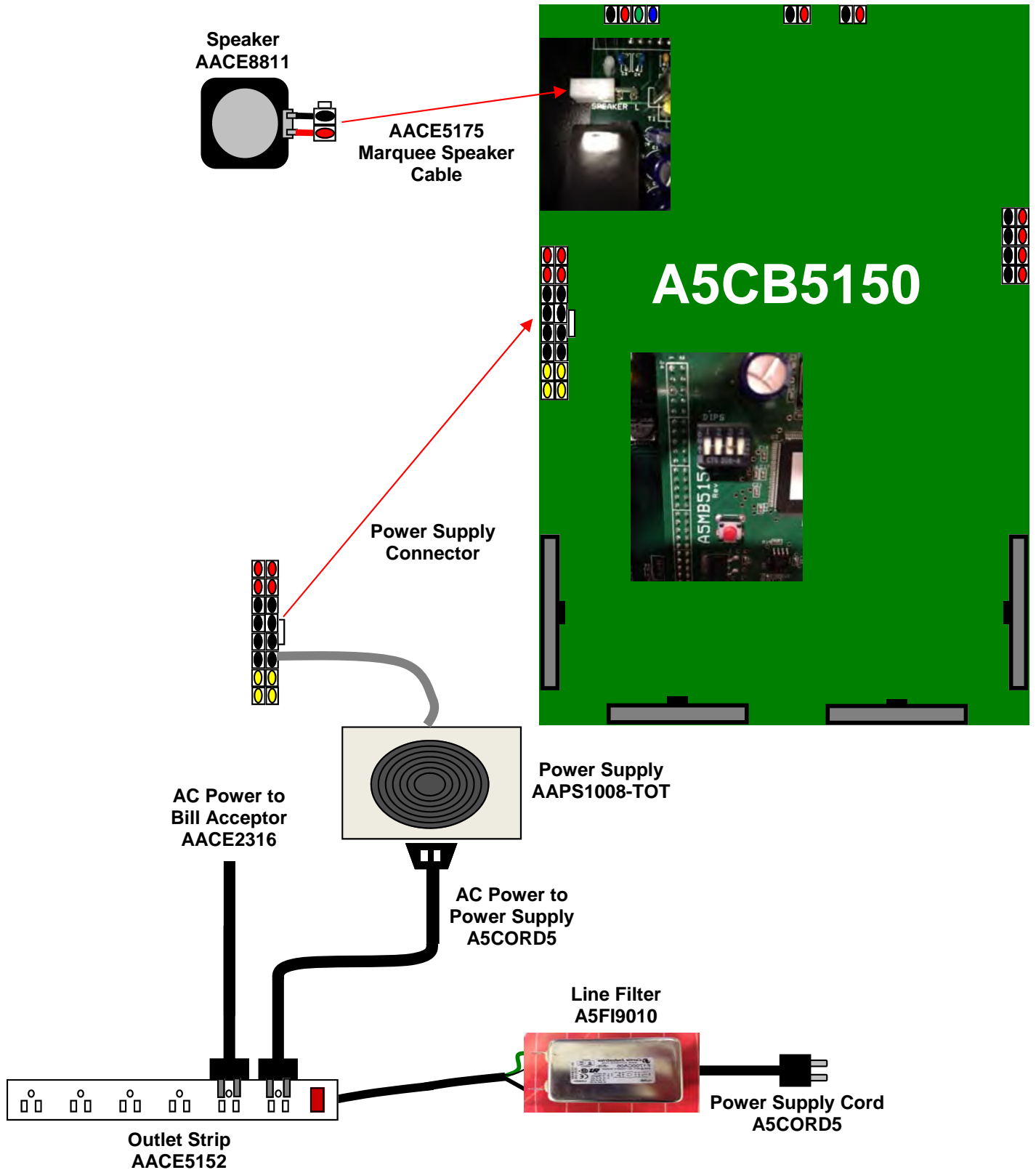

DOOR BOARD PINOUT (AACB5151)

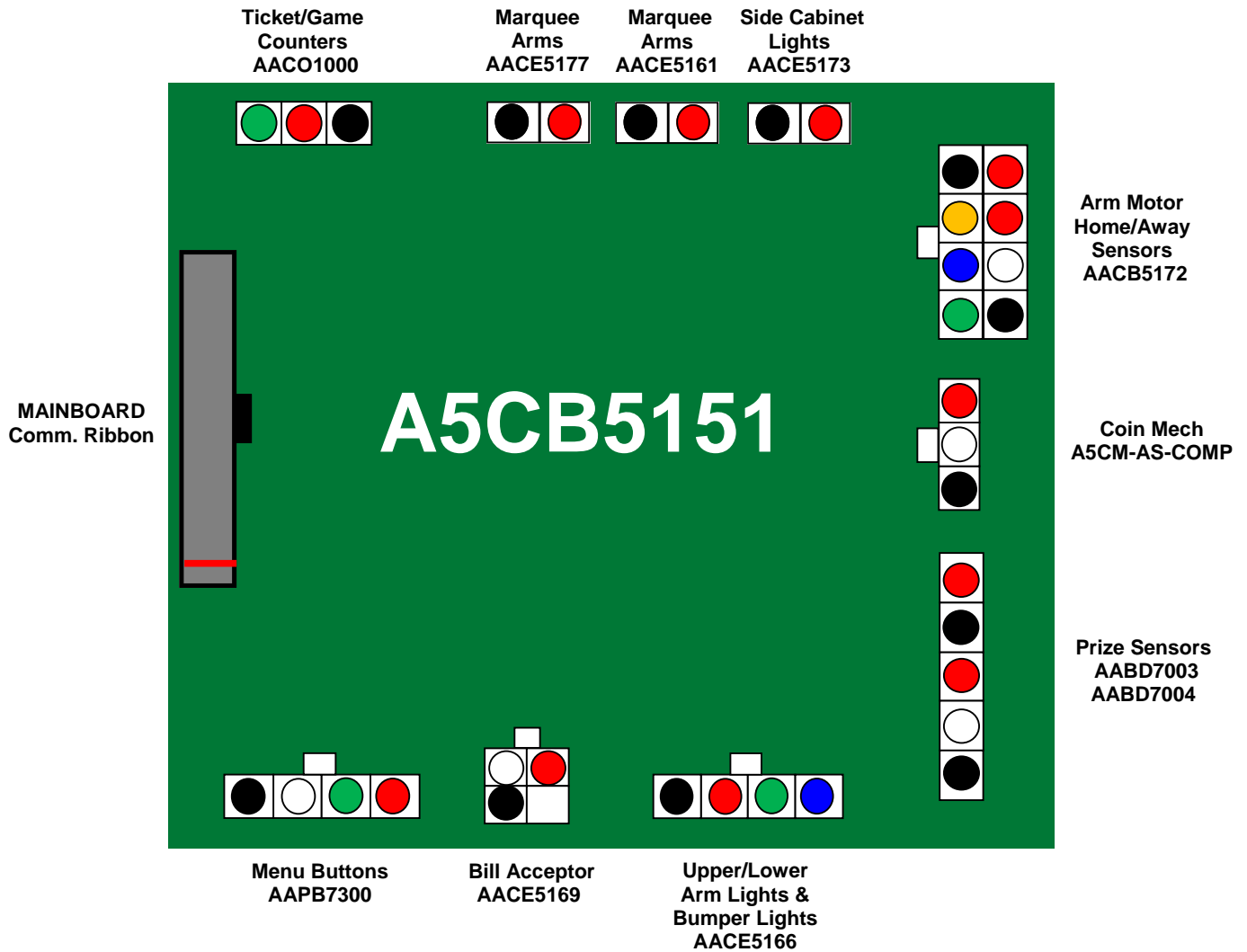

WIRING DIAGRAM: LIGHTS, SENSORS, MOTORS, DBA

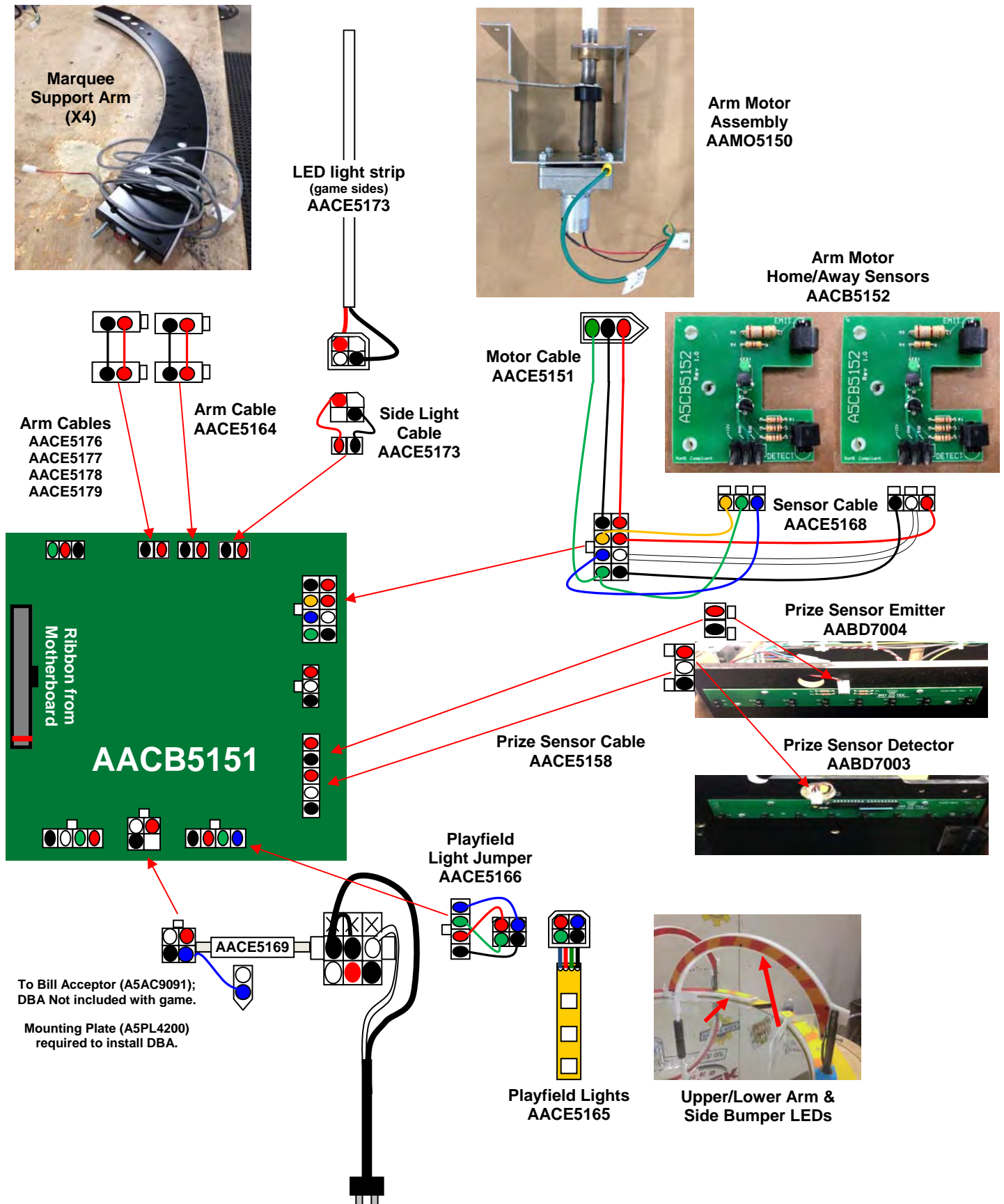

WIRING DIAGRAM: COUNTERS, COIN MECH, BUTTON

Coin Comparator
Set to NC



Coin Comparator
A5CM-AS-COMP



Counters
AACO1000

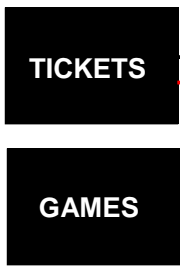

Counter Cable
AACE5156

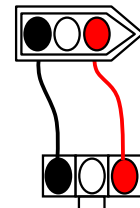
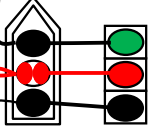

Coin Cable
AACE1527

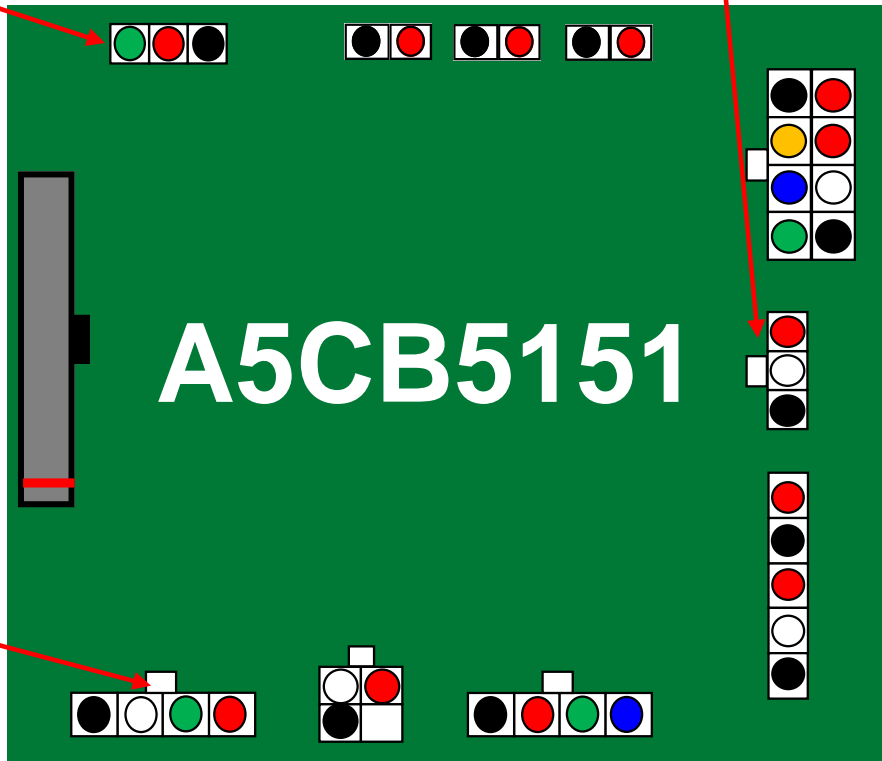

Player Button
A5PB7300

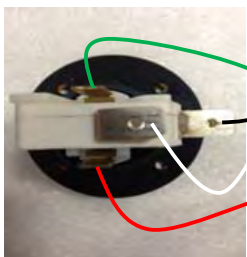



Player Button
Cable
AACE5155

TROUBLESHOOTING GUIDE

Troubleshooting Strategy

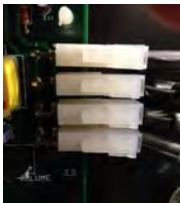
Use common sense and a systematic method of troubleshooting to determine the exact problem, probable cause and remedy. Use the process of elimination to find the faulty component. Always check for the simple and obvious causes first such as unplugged, loose or broken wires and bad sensors, bent, pinched, stuck or jammed components.

Problem	Probable Cause	Remedy
<p>No power to the game. No lights on at all.</p>	<p>Unplugged.</p> <p>Circuit breaker tripped.</p> <p>Power strip faulty.</p> <p>Faulty cable/power supply.</p>	<p>Check wall outlet.</p> <p>Reset power strip breaker switch or building circuit breaker.</p> <p>Change plug position, replace if needed.</p> <p>See Power Supply diagnostic below.</p>
<p>Game not coining up.</p>	<p>Ensure game makes sound when coin switch is triggered.</p> <p>Verify communication between Central Main Board and Door Board.</p> <p>Game set to large amount of credits per game.</p>	<p>Check coin switch—Should be wired normally closed. NC</p> <p>Check wiring to Door Board. Cable AACE1527</p> <p>Refer to “No Communication between boards” troubleshooting section.</p> <p>Check Central Board Pinout for switch to be set to the up position, NC.</p>
<p>No Sound</p> <p>Central Main Board controls sound</p> 	<p>Volume set to zero on Central Main board. (See Central Board Pinout)</p> <p>Disconnected, loose or broken wires.</p>  <p>Faulty speaker.</p>	<p>Turn up volume controls.</p>  <p>Check connections and reseat audio cable from Central Main Board to Speakers.</p> <p>Cables #</p> <p>Replace speaker. AACE8811</p>

TROUBLESHOOTING GUIDE

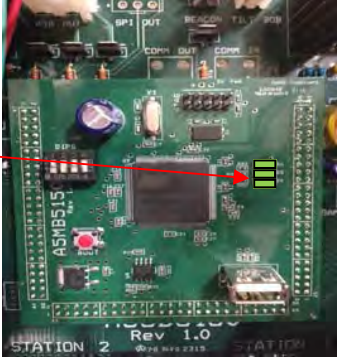
Problem	Probable Cause	Remedy
<p>No Communication between boards.</p>	<p>Main Board and WIRING TO Power Supply OK.</p> <p>Check green LED's on Central Main board.</p> <p style="text-align: center;">"Power" solid ON</p>	
	<p>If "Power" is not solid ON</p> <p>Ensure Power Supply Plug is plugged into blue "IN" socket on main board.</p> <p>Replace if needed</p> <p>Verify dipswitch 3 is on, Central Main Board.</p>	<p>If LEDs are not on</p> <p>Communication to Central Board is faulty.</p> <p>Check Power Supply Plug to Central Main Board.</p> <p>Replace Central Main, "Daughter Board".</p> <p>**MAKE SURE PWR IS OFF TO GAME AND ALL RIBBON CABLES ARE UNPLUGGED TO DOOR BOARDS**</p>
<p>Playfield Arms not responding / Player Push Button Problem.</p>	<p>Ensure switch on the push button is wired properly.</p> <p>Wire on Push Button or Motor broken.</p> <p>Motor to arm is plugged in</p>	<p>A. Trace wiring to Door Board.</p> <p>B. Button is bad.</p> <p>C. Replace button (A5PB7300)</p> <p>D. Replace Door Board (A5CB5151)</p> <p>A. Trace wiring to Door Board</p> <p>B. Motor is bad</p> <p>C. Replace motor (AAMO5150)</p> <p>D. Replace Door Board</p>

TROUBLESHOOTING GUIDE

Problem	Probable Cause	Remedy
Playfield Arms moving too far in/out	Home / Away Sensor under playfield is faulty Sensor wiring broken	A. Adjust Sensors in and out to stop arm movement. B. Trace wiring from Sensors to Door Board. C. Replace Sensor (AACB5152) D. Replace Door Board (A5CB5151)
Playfield Lights not working	Ensure cables for Marquee Arm Supports and Bumper lights are plugged into the corner of the game between the dome and console. Ensure all cables coming from the dome are plugged into the Door Board.	A. Trace wiring from dome to corner by the struts. Ensure all plugs are connected. B. Trace wiring from the struts in the corner of the cabinet to Door Board. C. Replace Support Arm Light cable (AACE5176-79 Under Arm, AACE5164 Over Arm) D. Replace Bumper Arm cable (AACE5165) E. Replace Door Board (A5CB5151)
Side Cabinet Lights not working	Ensure each stick light is plugged in at the corner of the game below the playfield.	A. Trace wiring from stick light to Door board. B. Replace Stick Light / Cable (AACE5173) C. Replace Door Board
Under Cabinet Glow not working	Ensure under cabinet glow cable is plugged in to Central Main Board.	A. Trace wiring from bottom of cabinet up to Central Main Board B. Replace Under Glow Cable / Light (AACE5171)

TROUBLESHOOTING GUIDE

Problem	Probable Cause	Remedy
Marquee Lights are out	Ensure Marquee Cable is plugged in at the intersection between the dome and cabinet, by the shocks.	<ul style="list-style-type: none"> A. Trace wiring from the corner of the cabinet to the Power Supply. The power supply is the feed for power on these lights. B. Replace Marquee Cable (AACE5170) C. Replace Marquee Lights (AACE5172) D. Test Power Supply, (AAPS1008-TOT), voltage
Beacon not working (Will be in operation for both attract and when a prize is won)	Ensure Beacon is plugged in at the top of the game along with the connection between the dome and cabinet in the corner.	<ul style="list-style-type: none"> A. Trace wiring from the side corner of the cabinet to the Central Main Board B. Replace Beacon Cable (AACE5182) C. Replace Beacon (AABA0002)
Ticket / Game Counters (Mounted on each station door) not responding	Ensure Counters are plugged in to the Door Board.	<ul style="list-style-type: none"> A. Trace wiring from Ticket/Game Counters to Door board B. Replace Counter Cable(AACE5156) C. Replace Counters (AACO1000)
Prize Sensor(s) not responding	Ensure Prize Sensors are in line with each other and are plugged in to the Door Board	<ul style="list-style-type: none"> A. Trace wiring from sensor to Door Board B. Open down coin game up, press player button and wave your hand in between the sensors. This should prompt the prize audio to play. C. Replace Prize Sensor Cable (AACE5158) D. Replace Sensors (AABD7004 Emitter (AACE5158 Detector)

BILL ACCEPTOR DIAGNOSTICS

Note: There are many different models and brands of Bill Acceptors that are used on redemption games. Your Bill Acceptor may differ from the unit shown. An up-stacker should be used for clearance issues. Standard DBA is MEI # AE2431-D5E Part # A5AC9091

Determine if Bill Acceptor has power:

Turn game ON—The bill acceptor should make noise as stacker cycles and green lights on outside bezel should flash.

If NO power: Use meter to measure 110 AC voltage at cable going into Bill Acceptor from power strip.

If power is OK: Clean Bill Acceptor path to make sure there is nothing jamming unit. Check dipswitch settings on side of acceptor.

Make sure switch # 8 is OFF for Always Enable

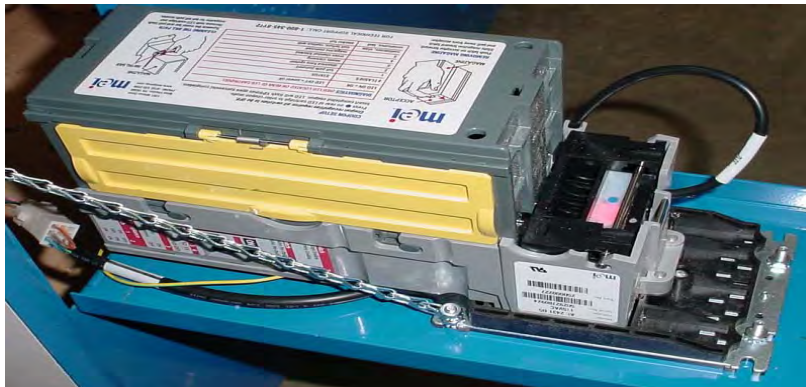

ERROR CODES

Count the number of flashes on front bezel of Bill Acceptor and follow chart for repair

REMOVING MAGAZINE
Push latch on acceptor forward.
Slide magazine toward latch
and pull away from acceptor.

COUPON SETUP
Coupon recognition requires all switches to be OFF.
Press ● on rear of LED cartridge to enter coupon mode.
Insert completed coupon. LED will flash 10 times upon successful completion.

DIAGNOSTICS (RED LED LOCATED ON REAR OF LED CARTRIDGE)

LED ON = OK	LED OFF = power off
# FLASHES	STATUS
1	bill path jammed
2	disabled from system
3	needs cleaning
4	cross channel blocked
5	magazine removed
continuous, slow	unit failure; replace unit
continuous, fast	stacker full

CLEANING THE BILL PATH
Squeeze the metal bar and go
Remove both LED cartridge &
magazine for full bill path

FOR TECHNICAL SUPPORT CALL: 1-800-345-8172

HOW TO: ACCESS MAIN & DOOR BOARDS

Unlock the Red Station access door.



Central Main Board (A5CB5150), Power Strip, and Power Supply can be accessed through this station.

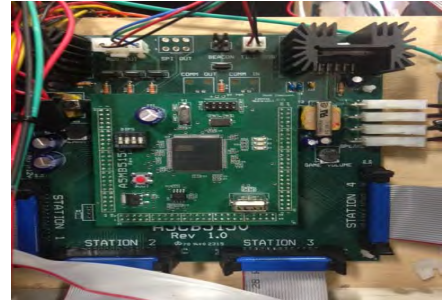

Each individual station has its own Door Board (A5CB5151) that can be accessed inside each door.



HOW TO: ACCESS PLAYFIELD

Unlock the two locks above the Red Station on top of the game.



Lift the Dome and it will hinge back allowing access to the playfield, prize sensors and game arms.



HOW TO: ACCESS MOTORS & CABLES

Power off the game before servicing.

Unlock the two locks above the red player station and lift the dome until it rests on its hinges. Opening the dome allows access to the playfield, prize sensors, and game arms.



Remove the (4) bolts/screws that secure the playfield.

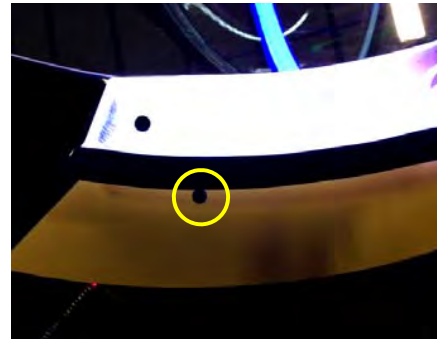

Disconnect the (5) motor cables and carefully lift the playfield off of the cabinet and set aside.

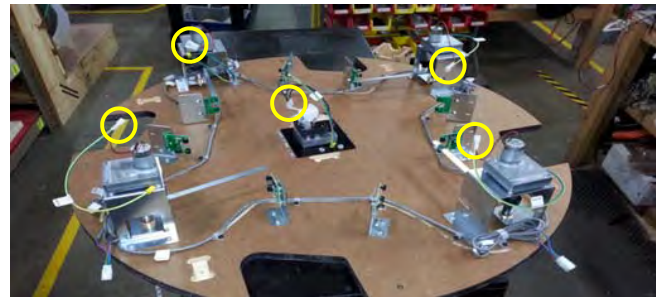

You can now access the motors, home/away sensors for each station and internal wiring of the game.

Removing the playfield also allows access to the player buttons and prize sensor wiring.

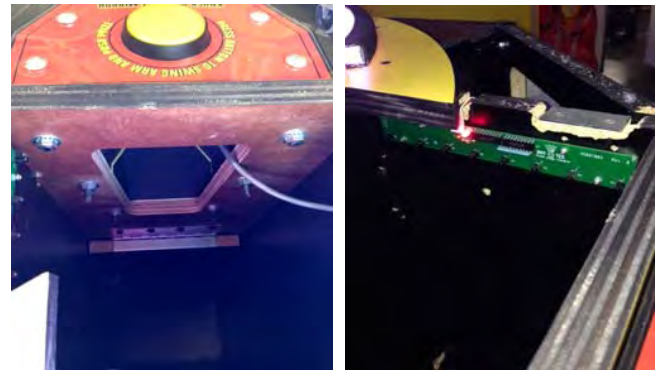

DECAL IDENTIFICATION

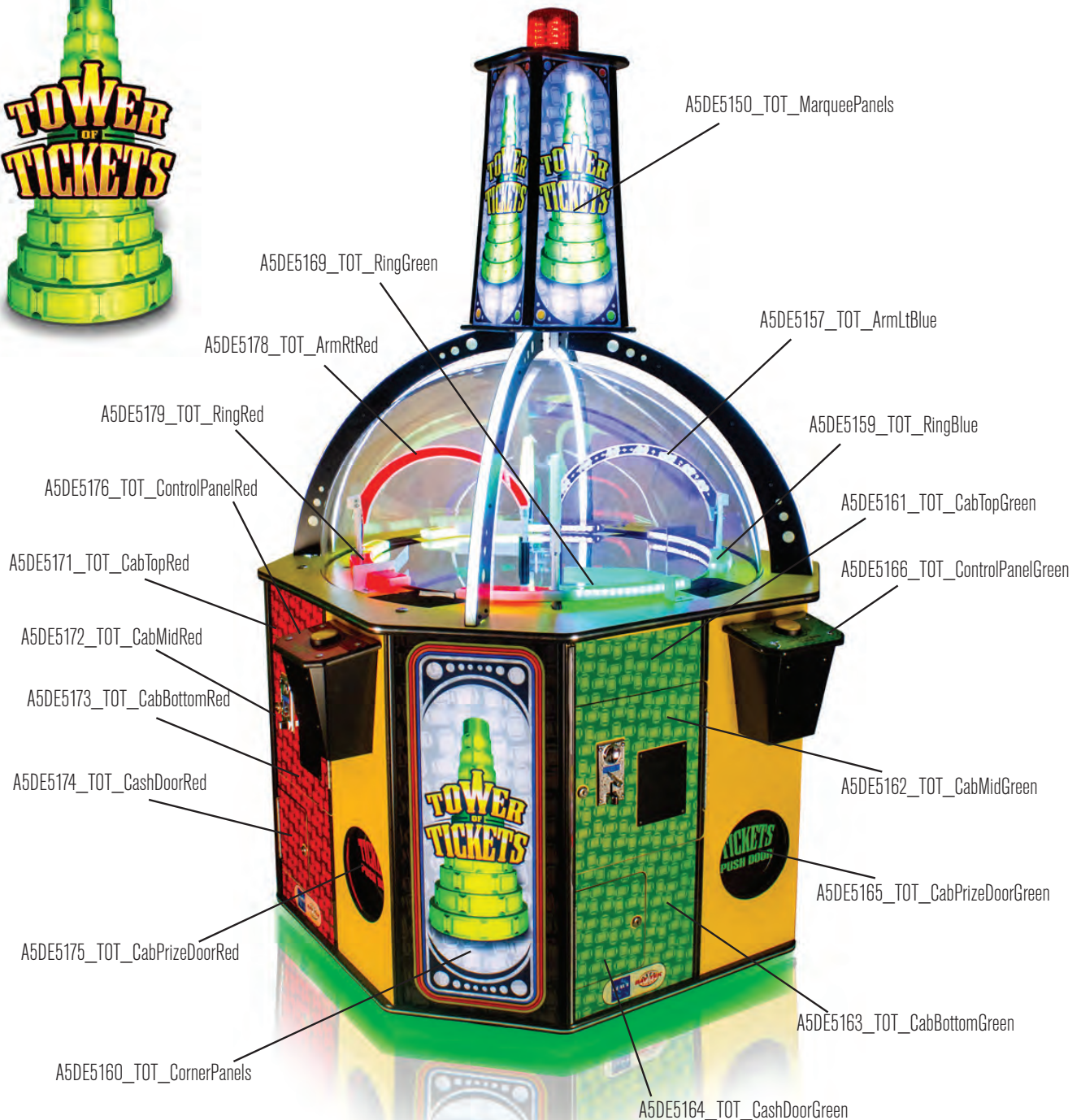

NOT VISIBLE ON PHOTO:

A5DE5151_TOT_CabTopBlue
 A5DE5152_TOT_CabMidBlue
 A5DE5153_TOT_CabBottomBlue
 A5DE5154_TOT_CashDoorBlue
 A5DE5155_TOT_CabPrizeDoorBlue
 A5DE5156_TOT_ControlPanelBlue
 A5DE5158_TOT_ArmRtBlue

A5DE5167_TOT_ArmLtGreen
 A5DE5168_TOT_ArmRtGreen
 A5DE5177_TOT_ArmLtRed
 A5DE5181_TOT_CabTopYellow
 A5DE5182_TOT_CabMidYellow
 A5DE5183_TOT_CabBottomYellow
 A5DE5184_TOT_CashDoorYellow

A5DE5185_TOT_CabPrizeDoorYellow
 A5DE5186_TOT_ControlPanelYellow
 A5DE5187_TOT_ArmLtYellow
 A5DE5188_TOT_ArmRtYellow
 A5DE5189_TOT_RingYellow

TECHNICAL SUPPORT

Excellent customer service is very important to Bay Tek Games!

We know that keeping your games in great operating condition is important to your business. When you need us, we are here to help. You can call us for free technical assistance, and you can count on us to have parts on-hand to support your game. We offer options that fit your needs.

Electronics / Circuit Boards - Repair Options

Repair & Return – If you have Circuit Board issues with your Bay Tek game, you can send the board to us and we'll repair it right away. Most items sent to us are repaired and returned to you within two days. This option is your best value as we offer this fast turn-around service at the most reasonable price.

Advance Replacement – If you have Circuit Board issues with your Bay Tek game, but you don't have time to send in your board in for repair, give us a call and ask for an Advance Replacement. We'll send you a replacement board that same day (pending availability). When you get your new board, just repackage the defective board in the same box and send it back to us. We make it easy by including a UPS Return Shipping label for you to put on the box (not available for international shipments). This is your best option when you need to get your game up and running as quickly as possible!

Spare Parts – Take matters into your own hands and purchase new spare Circuit Boards for your Bay Tek games. Many of our games share the same main-board electronics. This means you can buy one set of spare electronics to support many of your Bay Tek games. Spare boards allow you to get your game up and running the quickest and provide you a valuable troubleshooting option. Call our technicians to get recommendations for what you should keep on hand for spare parts!

Technical Support:

"You" are the best tool for troubleshooting! Your abilities to understand the game and your skills to repair the game are invaluable to us! If you need help, you know you can call us. It's not easy to diagnose a game remotely by phone, but our technicians do a great job. They'll need your help to perform some troubleshooting steps and convey to them exactly what's happening with your game.

Returns, Credits, & Fees:

NOTICE! ALL ITEMS being sent to Bay Tek Games for repair or return, etc. require prior Return Authorization! Bay Tek Games will provide a Product Return Form with an authorizing Ticket Number for each item to be returned. Please be certain to include this document with all shipments!

Late Fees and Non-Return Fees - Advance Replacement and Warranty Replacement items require the defective items to be returned by Bay Tek games promptly to avoid Late Fees. We expect items to be returned with 10 working days. Late fees are invoiced monthly. Late fees are non-refundable under any circumstance! Any item not returned within 90 days will be invoiced in full as a replacement part.

Bench Fees - Bench fees will apply for each electronic item returned to Bay Tek Games (this includes unused Advance Replacement items). This charge covers our cost to inspect, evaluate and retest each item. Please note that returned items that do not pass our tests will be charged accordingly as replacement items or advance replacements.

Restocking Fees - Unused items returned for credit will be credited minus a restocking fee. Items must be returned within 30 days of purchase in order to qualify for any credit amount. No shipping charges will be credited.

WARRANTY

Bay Tek Games warrants to the original purchaser that all game components will be free of defects in workmanship and materials for a period of 6 months from the date of purchase. If you fill out the registration card in the cashbox of the game, Bay Tek will add another 3 months to your warranty, free of charge.

Bay Tek Games will, without charge, repair or replace defective component parts upon notification to the parts/service department while the game is under warranty.

Warranty replacement parts will be shipped immediately, via ground service, along with a Product Return Form for the return of defective parts.

Defective parts must be shipped back to Bay Tek Games unless otherwise instructed. Items not returned to Bay Tek Games will be invoiced as replacement parts.

This warranty does not apply in the event of any misuse or abuse to the product, or as a result of any unauthorized repairs or alterations. The warranty does not apply if any serial number decal is altered, defaced, or removed from its original position.

 **ATTENTION** 

In order to maintain the safety & compliance certifications of this game, **ONLY** approved parts may be used. For approved replacement parts, refer to the parts list in this manual.

Should you need your game serviced, determine the serial number from the decal placed on the front of this manual, or locate it inside the game. Then contact our Service Department at: 920.822.3951 or e-mail: service@baytekgames.com

NON-WARRANTY

Options and estimated charges will be provided to you for your approval.

Please remember that any items being sent to Bay Tek Games must include prior return authorization from our Parts & Service Department.

This approval will include a Product Return Form which is required to be included with any incoming shipments. Repaired parts will be shipped back using the same method in which they were received.

Repairs are warranted for 30 days from the date of return shipment.