

SERVICE MANUAL

i-Cube

Ver 3.0



ISSUE DATE: Nov. 4, 2014



- ▶ Please read the manual carefully and keep it in mind before using this machine.
- ▶ Put this manual within touch of your reference in anytime.

PRECAUTIONS FOR USE

The following safety precautions are given throughout this manual. They must be strictly followed to protect those who install, use or maintain this product as well as to protect players, visitors and property.

For safety reasons.

- The following suggestions should be adhered to:



WARNING

Disregarding could result in serious injury.



CAUTION

Disregarding could result in injury or product damage.

- The following graphic suggestions describe the types of precautions to be followed.



Indicates a care should be taken.



Forbidden.



Indicates a matter which must be performed.

- **Precautions to be followed:**

Certain procedures require a qualified in-shop maintenance person or industry specialist. For such instructions, a qualified person must take care of the jobs.

- Otherwise an electric shock, machine trouble, or a serious accident may result.
- Replacing the machine parts, inspecting and maintaining the machines, and troubleshooting must be assigned only to a qualified in-shop maintenance person or industry specialist. This booklet gives instructions that hazardous jobs in particular must be handled by an industry specialist. Qualified in-shop maintenance person and industry specialist are defined as follows.

Qualified in-shop maintenance person

- A service staff shall have experience in operations of game machines. The staff shall be responsible for assembly, installation, inspection and maintenance of the machine.

Industry specialist

- An industry specialist must be engaged in designing, manufacturing, inspecting and servicing amusement machines. He or she must have an education in electrical, electronic and mechanical engineering, and routinely maintain and repair amusement machines.

PRECAUTIONS FOR USE

WARNING

If there is any abnormality such as smoke, bad smell or abnormal noise being emitted from the machine, immediately turn OFF the main power switch and unplug the power cord from the receptacle to stop operating it. 

- Using the machine in abnormal conditions could result in fire or accidents.

In case of abnormality

1. Turn OFF the main power switch.
2. Unplug the power cord from the receptacle.
3. Contact your nearest dealer.

Do not leave the power cord plugged in improperly or covered with dust. 

- Doing so could result the power cord periodically.

CAUTION

Do not use this product anywhere other than industrial areas. 

- Using in a residential area or an area next to a residential area could affect signal reception of radios, television sets, telephones, etc..

- Do not give shock the surface of glass products.

- Please do not play this game if
 - When you do drinking;
 - When your physical condition is not normal;
 - When you are in pregnancy;
 - When you have on a pulse controller;
 - When you have recently experienced a cramp or fainting away while watching TV.
- Avoid excessive force/shock while playing/moving the game.
- While do games, pay attention to surrounding.

Do not plug or unplug the power cord with wet hands. 

In handling the power cord, follow the instructions below. 

- | | |
|---|--|
| • Do not damage the power cord. | • Do not modify the power cord. |
| • Do not bend the power cord excessively. | • Do not twist the power cord. |
| • Do not heat the power cord. | • Do not pull the power cord. |
| • Do not bind the power cord. | • Do not stand on the power cord. |
| • Do not sandwich the power cord. | • Do not drive a nail into the power cord. |

If the power cord or power plug becomes damaged, stop using the machine immediately and ask your nearest dealer to replace the parts.

PRECAUTIONS FOR USE

WARNING

Be sure to consult an industry specialist when setting up, moving or transporting this product.

- This product should not be set up, moved or transported by any one other than an industry specialist.
- When installing this product, set the 4 leg levelers evenly on the floor and make sure that the product is installed stably in a horizontal position. Unstable installation may result in injury or accident.
- When installing this product, do not apply undue force on movable parts. Otherwise, injury and accident may result, or the product may be damaged.

The machine for indoor usage only does not install outside.



Do not set the game machine up near emergency exits.



Protect the game machine from:

- Rain or moisture.
- Direct sunlight.
- Direct heat from air-conditioning and heating equipment, etc..
- Hazardous flammable substances.
- Otherwise an accident or malfunction may result.



Do not place containers holding chemicals or water on or near the game machine.



Do not place objects near the ventilating holes.



Do not bend the power cord by force or place heavy objects on it.



Never plug or unplug the power cord with wet hands.



Never unplug the game machine by pulling the power cord.



CAUTION

Be sure to use indoor wiring within the specified voltage requirements. For extension cord, use the specified rating or more.

Be sure to use the attached power cord.

Never plug more than one cord at a time into the electrical receptacle.



Do not lay the power cord where people walk through.



Be sure to ground this product.



Do not exert excessive force when moving the machine.



For proper ventilation, keep the game machine 100mm(4") away from the walls.

Do not alter the system related dipswitch settings.

PRECAUTIONS FOR USE

⚠ WARNING

Be sure to turn OFF the main power switch and unplug the power cord from the receptacle before inspecting or cleaning the machine.



When replacing parts, be sure to use parts of the correct specifications. Never use parts other than the specified ones.



Opening inside the machine shall be done by machine specialist only as high electric current is being sent inside. For game machine with monitor, a care should be taken while opening its back door. If not, a damage to the inside parts or the monitor may occur.



If the sub power switch of the service panel is turned OFF without turning OFF the main power switch of the power supply unit, some parts in the units remain live. When opening the back door, be sure to turn OFF the main power switch and unplug the power cord from the receptacle.



Strictly refrain from disassembly and repair of parts which are not indicated in this manual, as well as settings and remodeling.



To clean the game machine, wipe it with a soft cloth dampened in a neutral detergent.

- Using thinner or other organic solvent or alcohol may decompose the material.
- Electrical shock or equipment failure could be caused by water entering the inside of the machine.

⚠ CAUTION

Components in the game are sensitive to vibrations and impact. Care should be used when moving and transporting the game machine.



Be sure not to let the machine tip over.

Before moving the machine, be sure to turn OFF the main power switch, unplug the power cord from the receptacle and remove the power cord from the machine.



Before moving take the machine, off the levelers and move it on the casters.

Avoid excessive force while moving the machine.

.....

PRECAUTIONS IN HANDLING

- When setting up, inspecting, maintaining, moving or transporting this product, follow the procedures and instructions set forth in this manual and perform such work safely.
- Do not set up, handle, inspect, maintain, move or transport this product under conditions equivalent to the condition of "WARNING" or "CAUTION" specified in this manual.
- If a new owner is to have this product as a result of transfer, etc., be sure to give this manual to the new owner.

CONTENTS

1. SPECIFICATION AND DIMENSION	P02	7. TROUBLESHOOTING	P25
1-1. DIMENSION	P02	7-1. IN CASE OF POWER FAILURE	P25
1-2. SPECIFICATION	P02	7-2. MOTOR ERROR	P26
1-3. NAME OF PARTS	P03	7-3. MICRO SWITCH ERROR	P26
1-4. STICKER LOCATION	P04	7-4. COIN SELECTOR ERROR	P27
1-5. COMPONENTS	P04	7-5. SOUND ERROR	P28
2. INSTALLATION	P05	7-6. BUTTON & COUNTER ERROR	P29
2-1. INSTALLATION	P05	7-7. SETUP LCD PCB ERROR	P30
2-2. PRECAUTIONS FOR USE	P05	7-8. UPPER SIDE LIGHT PCB & CREDIT FND, TIME FND ERROR	P31
2-3. READER AND CARD READER	P05	8. PART LIST	P32
RELATED BILLS		8-1. EXPLODED VIEW	P32
2-4. HOW TO INSTALL BILLBOARD	P06	8-2. LIST	P33
2-5. HOW TO INSTALL	P07	9. WIRING DIAGRAM	P34
3. GAME CHARACTERISTICS	P08		
4. HOW TO PLAY	P08		
5. SETUP SETTINGS	P09		
5-1. MACHINE SETUP	P09		
5-2. STATUS MODE	P10		
5-3. SETUP MENU	P12		
* GSM SENDING MESSAGE LIST	P16		
5-4. TEST MENU	P17		
5-5. ERROR CODE	P21		
6. HOW TO REPLACE MAJOR	P23		
COMPONENTS			
6-1. REPLACING MAIN PCB & IO PCB	P23		
6-2. REPLACING COIN SELECTOR	P23		
6-3. REPLACING PRIZE DISPENSER MICRO SWITCH & MOTOR	P24		

1. SPECIFICATION AND DIMENSION

1-1. DIMENSION

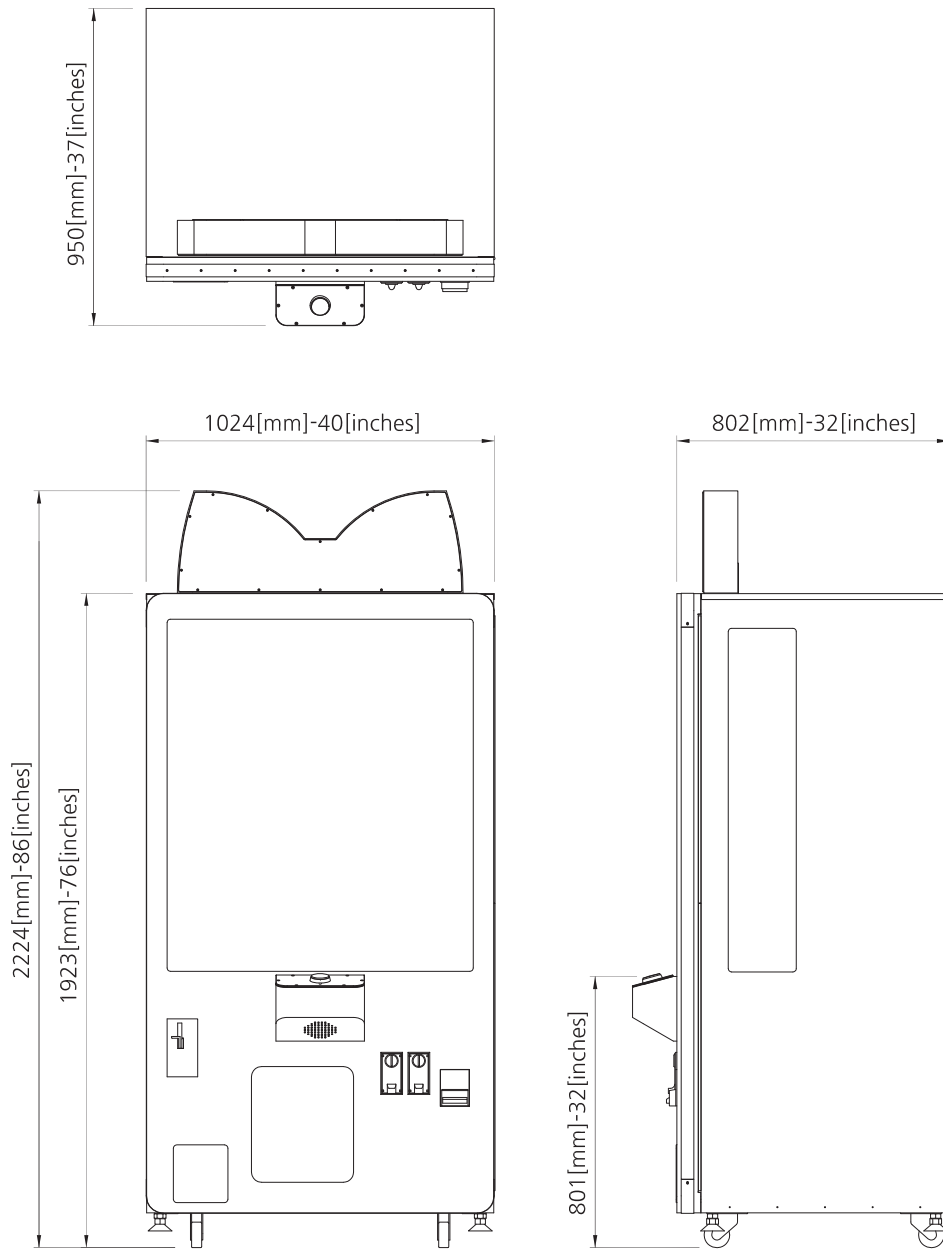

1-2. SPECIFICATION

DIMENSION(W x D x H)	984 x 950 x 1853 (mm)
PACKING DIMENSION (W x D x H)	1150 x 850 x 2050 (mm)
WEIGHT (kg)	283kg [WEIGHT INCLUDING PACKAGING : 300kg]
VOLTAGE	AC 110V / AC 220V
FREQUENCY RANGE	60Hz
CONSUMPTION	180W
CERTIFICATION	-

1-3. NAME OF PARTS

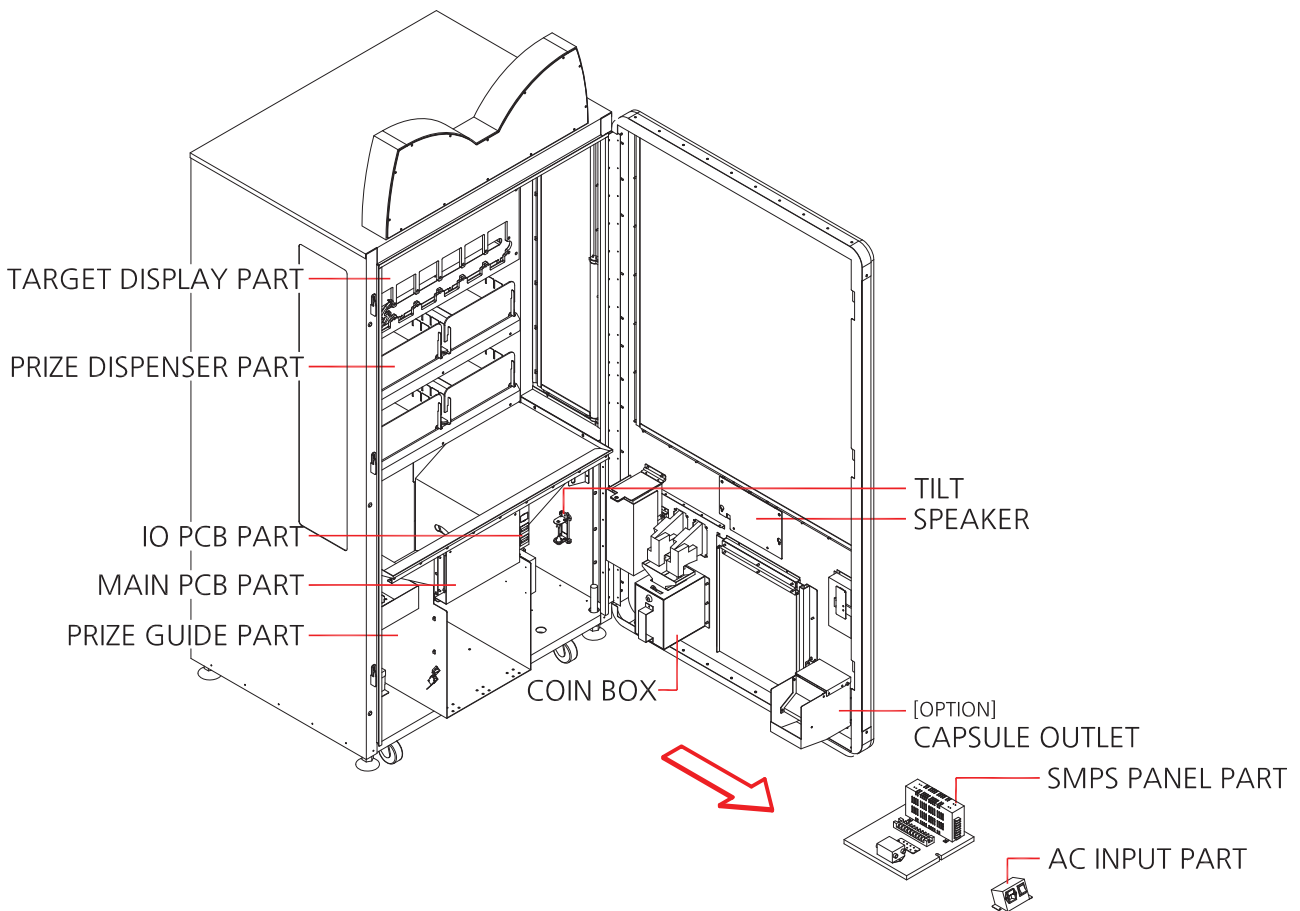
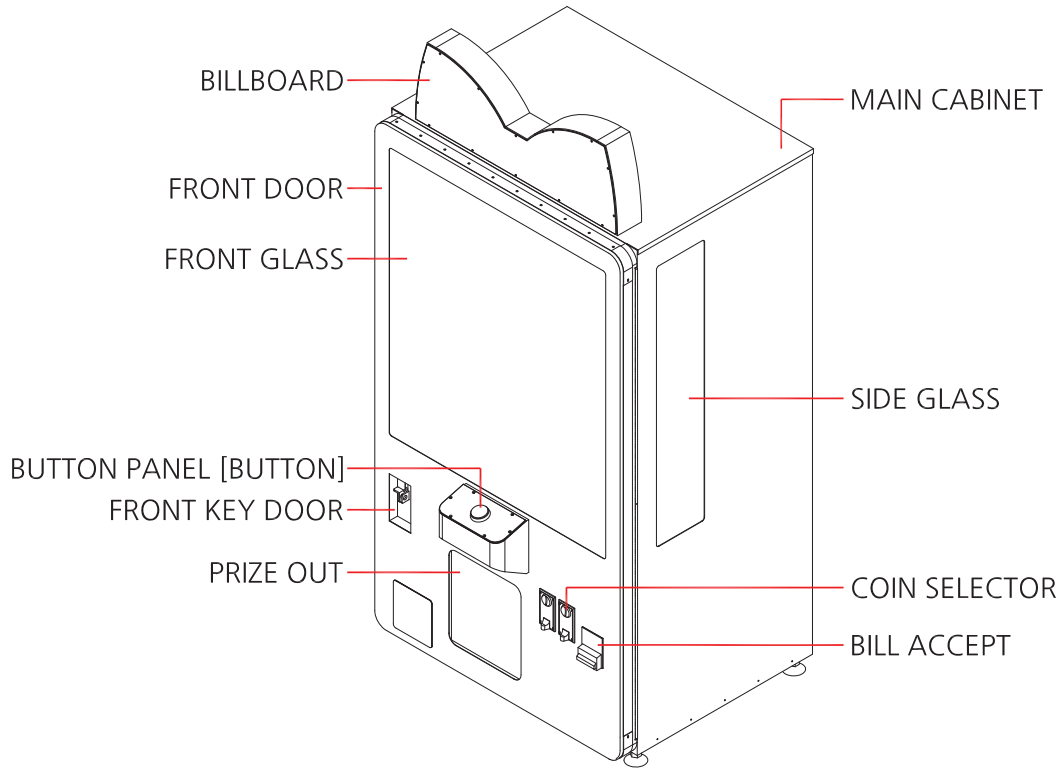

1-4. STICKER LOCATION

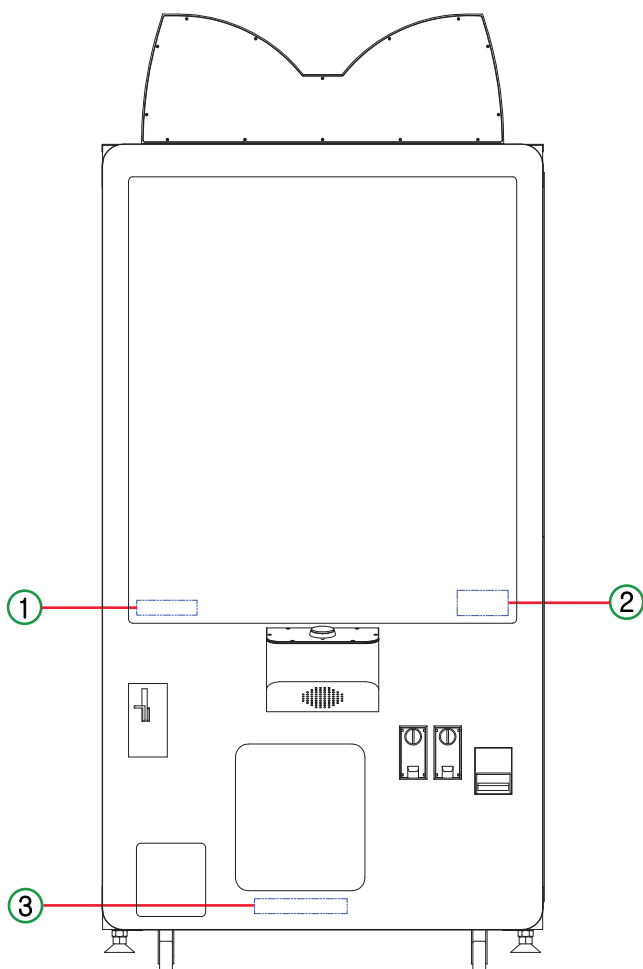

①



**DO NOT PUSH OR HIT THIS.
IT WOULD BE DAMAGED.**

: Do not beat me up by sliding glass.
May be damaged.

②

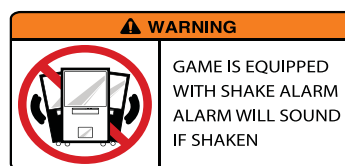

WARNING
GAME IS EQUIPPED
WITH SHAKE ALARM
ALARM WILL SOUND
IF SHAKEN

: An alarm to sound when shaken products
Alarm is equipped with a device.





③

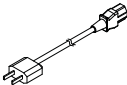

Watch your head or hands!

: Beware of the head and hands exit prizes.

1-5. COMPONENTS

NO.	PART NAME	SPEC.	QTY
1	AC POWER CORD	110V or 220V 	1
2	KEY	6001 	2
3	BOLT	M4x10L 	8
4	WRENCH	2.5mm, 4mm 	1
5	MANUAL	- 	1

2. INSTALLATION

2-1. INSTALLATION SPACE

- Need to have installation place.
Maintenance Zone & Play zone should have at least 2000mm x 2000mm each.

IMPORTANT

- Please make sure to reserve installation space as following.

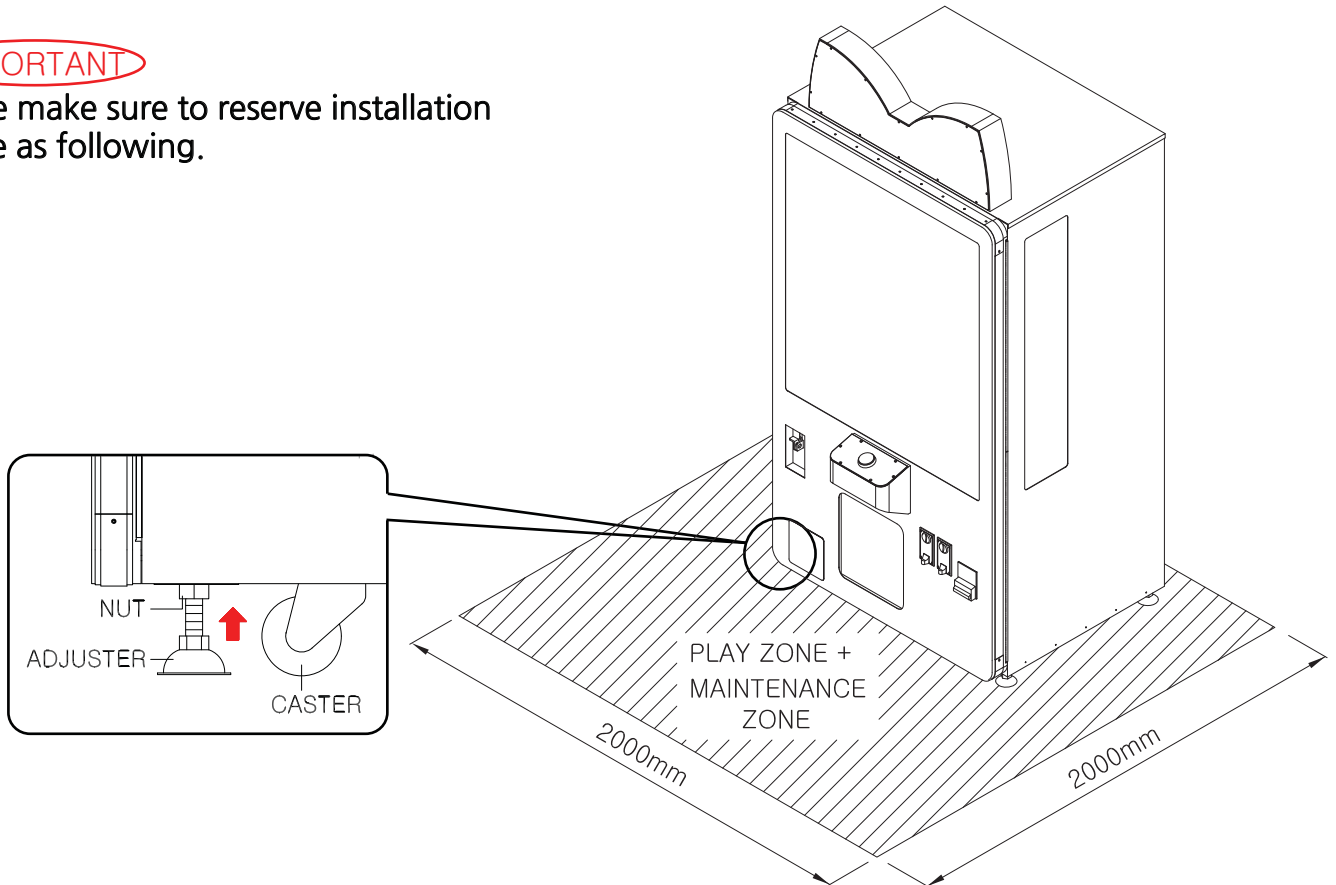

2-2. PRECAUTIONS FOR USE

- * Optimum temperature for game operation is between -10°C to 45°C . Installing/operating the game outside given temperature range may cause malfunction or damages to the components.

2-3. READER AND CARD READER RELATED BILLS

- This machine can install Credit Card Reader or Bill Acceptor as an Option.

2-4. HOW TO INSTALL BILLBOARD

1



- Separate cabinet inside the left connectors [Photo display]

2



- Loosen the bolts [Photo display] and separate the Fluorescent Lamp Ass'y. [4 places]

3

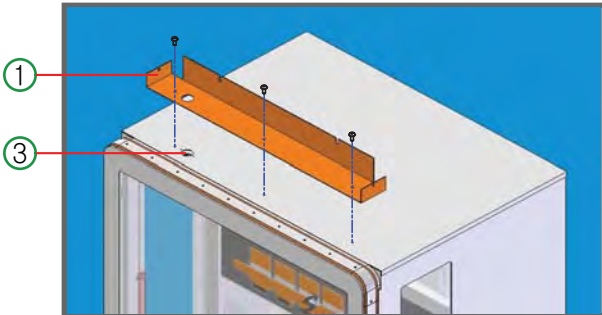

- ① BFix BILLBOARD PART FIX BKT by fasten M6 bolts on the upper side of cabinet. [3 places]

4

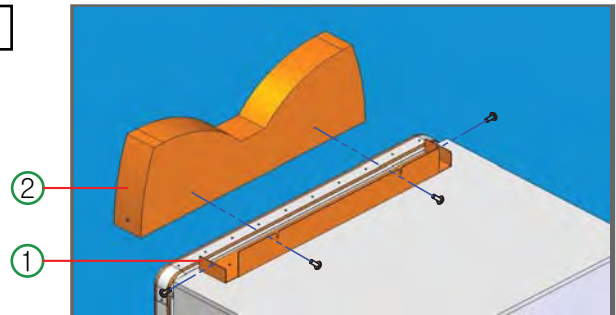

- ② Combine BILLBOARD FRAME and ① BILLBOARD PART FIX BKT [M6 bolts, 4 places]

5

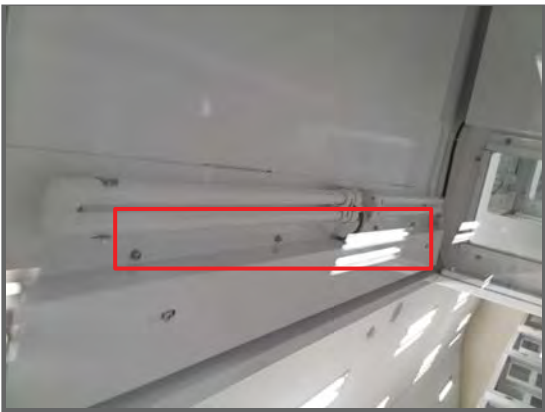

- Assemble the Fluorescent Lamp Ass'y. [4 places]



* Before an installation, have external BILLBOARD FRAME connector to pass through the hole shown in ③

6



- Assemble cabinet inside the left and right connectors [Photo display] to assemble.

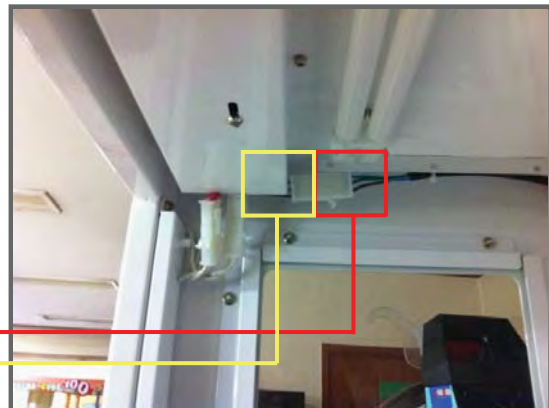

- — Connect between red indicator connectors.

- — Reconnect the connector to the yellow indicator.

2-5. HOW TO INSTALL

1

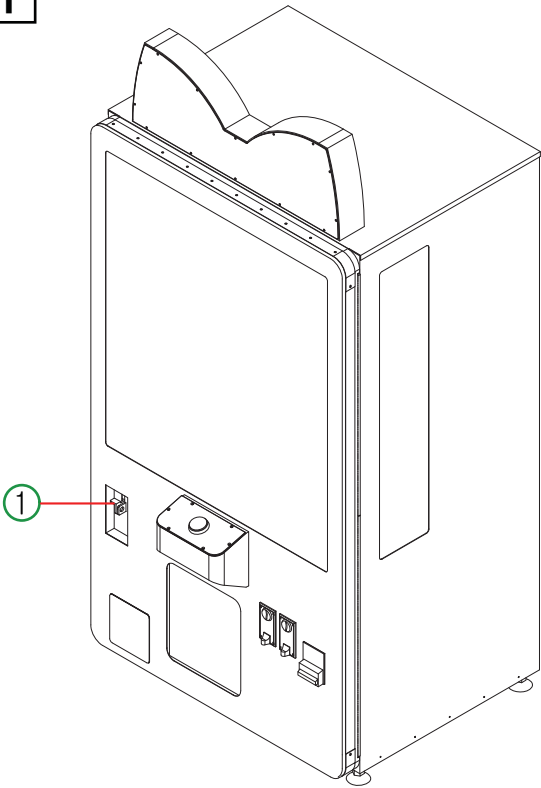

- ① Open door using door bracket.

2

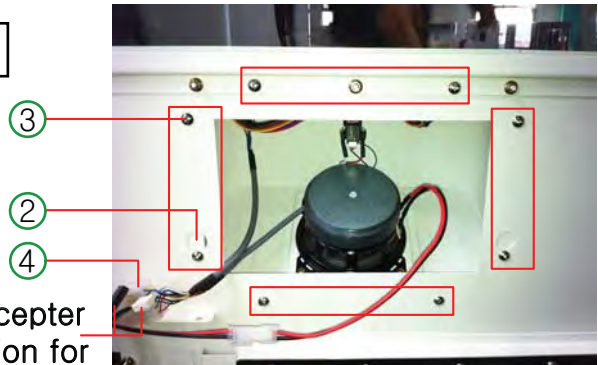

* BILL Acceptor connection for connector

- After fasten bolt in Button panel Ass'y, hang it on cabinet using holes (2Ea: ②). Then fasten rest of bolts (M4 bolt x 8Ea). Connect main connector with cable from button panel ass'y

3



- Complete the Ass'y as shown picture.

4



- Connect AC Cord in Control panel ⑥ through internal hole ⑤ and fix it with cable tie ⑦.

3. GAME CHARACTERISTICS

- 3-1.** i-Cube is a prize redemption game with most accurate payout control using the stepping motor.
- 3-2.** Unsurpassed ample prize display capacity enables operator to use various eye-catching prizes, and making iCube the most operator-friendly prize redemption game.
- 3-3.** Unsurpassed ample prize display capacity enables operator to use various eye-catching prizes, and making iCube the most operator-friendly prize redemption game.
- 3-4.** Optical illusion, orchestrated by the hidden delicate designs on the moving arm and the target holes, boosts confidence of the players.
- 3-5.** Payout can be set at 1 to 9999.
- 3-6.** It's attention-grabbing, sophisticated, modern design will ensure iCube a prosperous and luxurious addition to all locations.

4. HOW TO PLAY

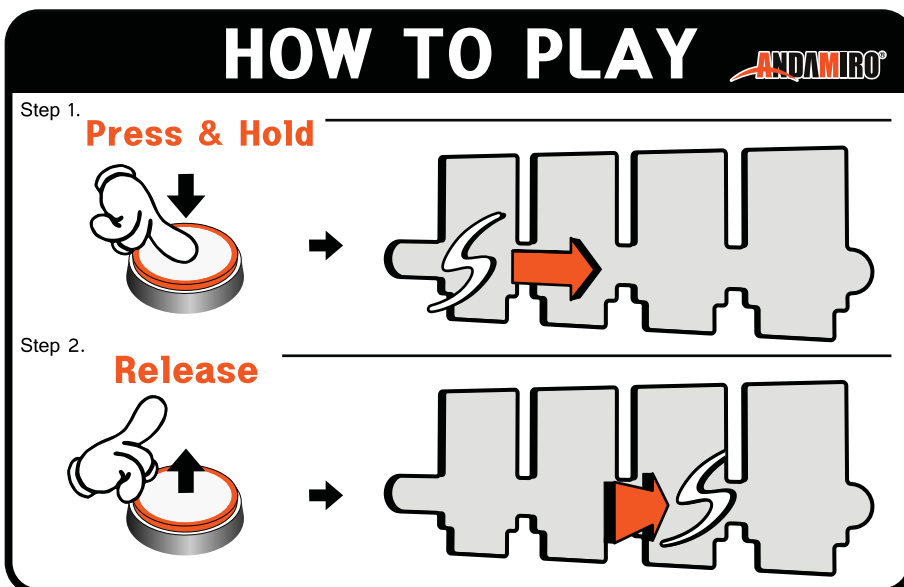

- 4-1.** Choose a desired prize on display either by numbers or A,B.
- 4-2.** When the arm reaches the target hole, release the button. The arm to target number/A,B
- 4-3.** Release the button when the arm reaches the target hole. When the arm enters the hole successfully, desired prize pays out.
- 4-4.** Unsuccessful trial ends the game.

5. SETUP SETTINGS

5-1. MACHINE SETUP

1. HOW TO ENTER SETUP MENU

- 1 There is "Control panel" inside cabinet. User may set any setting using following.

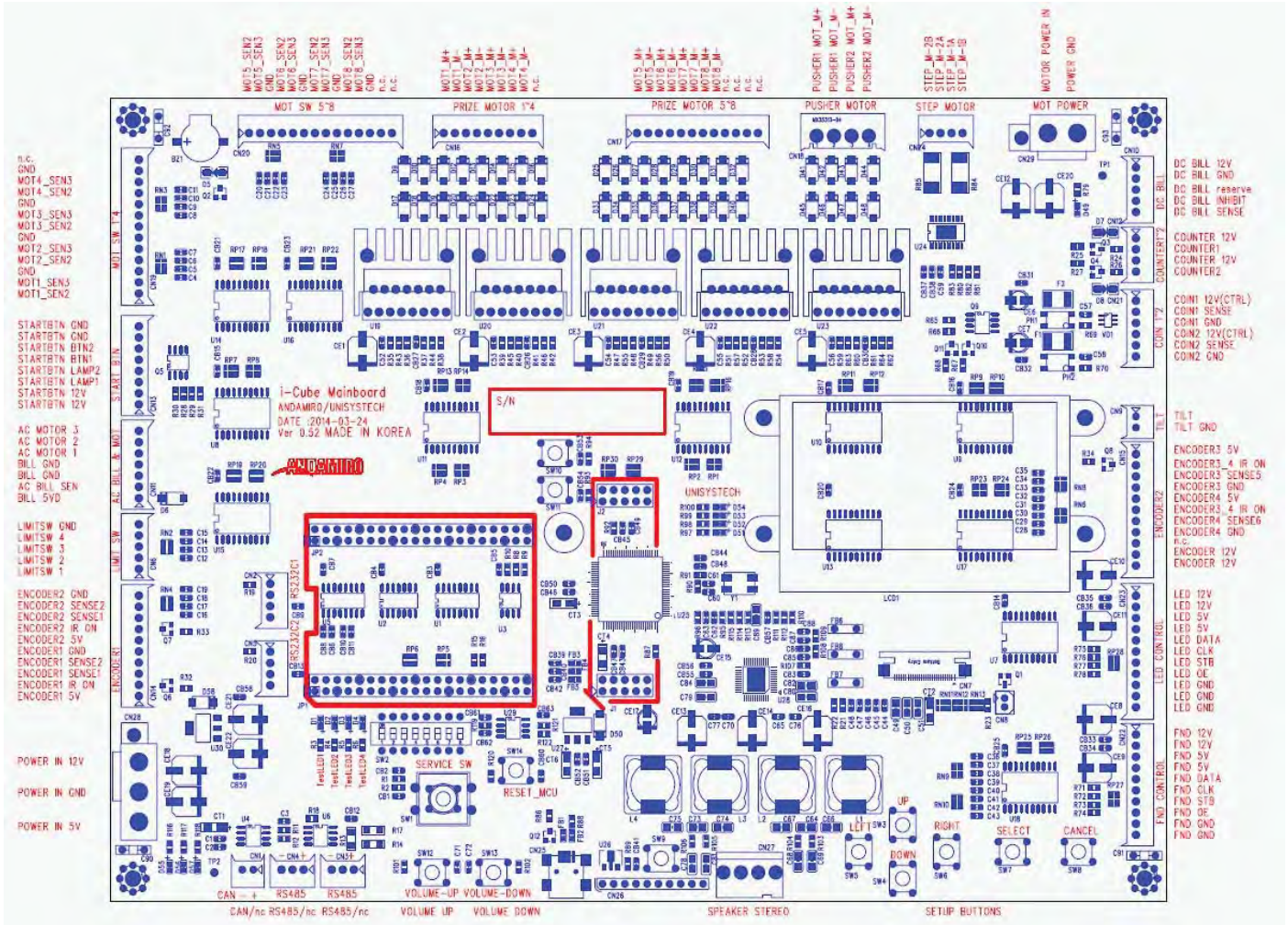

[MAIN PCB]

2. SOUND VOLUME

- On the left below of AO mainboards, 2 buttons for Sound volume of the game exist Left button to lower volume, Right button to higher it. The basic set value is **88**. It adjusts by 2, you can set from 0~100
- If you push the button on Total Status Window, the Volume value shows as belowed Window in a moment and then come back to the original screen

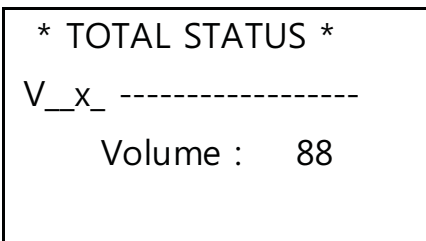

3. SERVICE BUTTON

- On the below of CPU in Cube AO Mainboard, there is a button for providing the Free Credit or the Credit for Gaming in a case of Test
For each puching the button, Play Credit is increasing by 1. Counter Meter does not being increased.

4. SETUP LCD & SET BUTTON

- The SETUP LCD on the right side of Cube AO Mainboard has fuctions for checking the machine status or changing, saving and testing the user set value.
When you power on, below screen shows and Program Version displays.

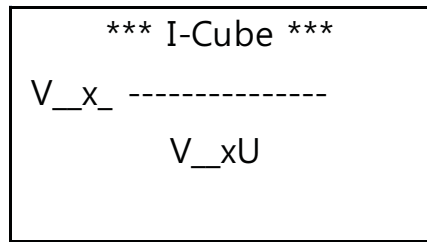

Basic Type

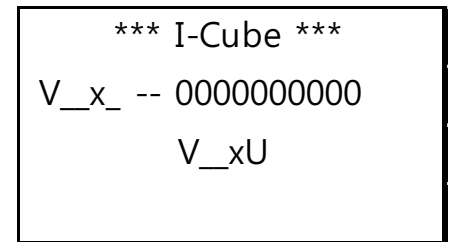

GSM Version(Optional)

5. BUTTON INSTRUCTIONS FOR USE

- There are Up/Down/Right/Left/Select/Cancel button on panel.
All buttons can perform different functions depending on whether it's a short press or a long press & hold on the button(s).

- [↑ ↓] Up/Down Button : To move up and down the menu.
- [← →] Left/Right Button : To change the set values (-/+) after pressing Select button.
- SELECT Button : To select desired menu. Changing Set Value.
- CLEAR Button : To reset to Factory setting / Calibration

- * **Calibration of I-Cube is the first thing you should do when you start the machine for the first time after installation.**
Calibration is testing the functions of components and can affect the setting of the payout rates
Calibaration can be performed by Calibration of SET MENU.

5-2. STATUS MODE

1. COIN COUNT

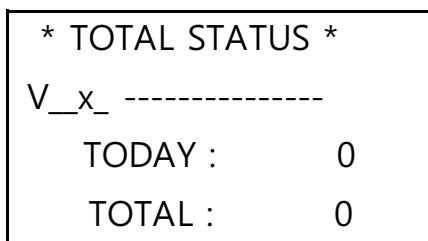

- 'TODAY' DISPLAYS THE INSERTED COINS AFTER OPERATORS INITIALIZE THE SATUS
1) On the field, Operators can initialize by long-key on [CLEAR] button
2) Or by performing "Initialize setup"
- 'Total' is total inserted coins, It is impossible to erase and it can not be erased.

2. TOTAL PRIZE OUT

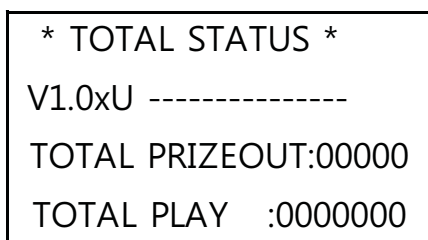

- '**TOTAL PRIZE OUT**' is total Quantity of Prizes out
1) On the field, Operators can initialize by long-key on [CLEAR] button
2) Or by performing "Initialize setup"
- If it succeeds, the prize of allocated holes will be dispensed and 1 will be added when the Pusher bar comes back to origin point
'TOTAL PLAY' is total game played times, Bonus games also include.
It is impossible to erase and it can not be erased.

3. CREDIT COUNT

```

* TOTAL STATUS *
V__x_ -----
      CREDIT COUNT
      00  +00
    
```

- Displays a two-digit display, up Credit Limit set by the Set Menu. Play quantities and can be injected, including the corresponding bonus amount 00 in front of, The number of the service du Coin is +00. The front panel displays the combined quantity gaming Credit FND has.

4. PRIZE OUT & PLAY COUNT (CELL A,B & 1~6)

<pre> * ROW STATUS:A * V__x_ ----- nRND ,CNT ,PRZ,TOTAL A 999 0 0 00000 </pre>	<pre> * ROW STATUS:B * V__x_ ----- nRND ,CNT ,PRZ,TOTAL A 999 0 0 00000 </pre>	
<pre> * ROW STATUS:1 * V__x_ ----- nRND ,CNT ,PRZ,TOTAL A 999 0 0 00000 </pre>	<pre> * ROW STATUS:2 * V__x_ ----- nRND ,CNT ,PRZ,TOTAL A 999 0 0 00000 </pre>	<pre> * ROW STATUS:3 * V__x_ ----- nRND ,CNT ,PRZ,TOTAL A 999 0 0 00000 </pre>
<pre> * ROW STATUS:4 * V__x_ ----- nRND ,CNT ,PRZ,TOTAL A 999 0 0 00000 </pre>	<pre> * ROW STATUS:5 * V__x_ ----- nRND ,CNT ,PRZ,TOTAL A 999 0 0 00000 </pre>	<pre> * ROW STATUS:6 * V__x_ ----- nRND ,CNT ,PRZ,TOTAL A 999 0 0 00000 </pre>

Press {Up} and {Dn} buttons to move to desired cell number

n : Lock Status / o : Unlock Status

Remains "Unlock" until "Prize Out" number matches the set "Pay Out" value.

For Example, if payout rate(RND) is set at 10 with zero Prize Out(PRZ), and unsuccessful attempts(CNT) reaches 30,

S-Cube remains "Unlock" until it pays out three prizes to match its' Payout rate.

RND : Payout rate

CNT : Count of unsuccessful attempts

PRZ : Prize out count

TOTAL : Toal play count

Of previous odds and emission displays, A 1, B, A OR B is twice

5. TILT(SHAKE) ERROR COUNTS

```

* ERROR TILT=00X *
V__x_ -----
      CREDIT COUNT
      00  +00
    
```

X : Error Tilt error counts

Tilt Error is when the machine get some outside shock. When Tilt gets contacts more than 1 time, Error Event will proceed for 10 secs and then transfer to the normal mode.

Press [CLEAR] button to initalize the TILT ERROR count.

5-3. Press and hold [SELECT] button in "STATUS MODE" to enter "SET-UP MENU".

1. VERSION DISPLAY

```
*SET MENU *
V_x_ -----
***** I-Cube *****
ANDAMIRO V_xU
```

2. PAYOUT SET-UP

```
*SET MENU *
V_x_ -----
Hole X-N
      0999 +/- 1
```

(N = Hole No.1~6)

* SETTING PAYOUT

*** The setting range is 1~9999 (Default : 0999)

- 1) Press [SELECT] button to enter "PAYOUT SET-UP"
- 2) Change values by LEFT/RIGHT Button. The l of right side display units by 10, 100, 1000.
- 3) Press {<} or {>} to increase or decrease the value from 0 to 9.

{<} : Increase, {>} : Decrease

- 4) Press [SELECT] button to save.

* Prizebox REMOVE FUNCTION

Prize Out function of a specific prize cell can be disabled in case of malfunction of parts such as front/rear motor, and switches.

- 1) Press [SELECT] button to enter "PAYOUT SET-UP" (Default : 0999).
- 2) Press [Up] or [Down] button to move from 1's to 1000's.
- 3) Press {<} or {>} button to change the value from 0 to 9 on each digit.

{<} : Increase, {>} : Decrease

- 4) **Change the payout rate to "0" for a specific prize cell, and "Disabled: n"(n =prize cell number, A,B, or 1~6) appears on FND as below:**

```
*SET MENU *
[Disabled: 1      ]
Hole X-1
      [Disabled]
```

- 5) Press [SELECT] button to disable the specified prize cell.
- 6) Is displayed on all the screen is still Prizebox.

```
* TOTAL STATUS *
[Disabled: 1      ]
TODAY :          0
TOTAL :          0
```

- 7) In order to recover the function after repairing PrizeLoader, change the probability of the allocated hole into the value you want.

3. CHANGING CALIBRATION STARTING POSITION

```
*SET MENU *
V_x_ -----
      Offset: 000
```

- You may change the starting position to the right of each target.
- 1) Setting range is **-20 ~ +20** (Default : **000**).
 - 2) Press [SELECT] button to enter "PAY OUT SET-UP" (Default : **000**).
 - 3) Change the Values by [Up],[Dn]Button.
{↵} : Increase, {⇩} : Decrease
 - 4) If you set (-) value, the origin point moves more left to the basic location. If you set (+) value, the origin point moves more right to the basic location.
 - 5) Press [SELECT] button to save all changes.

4. 1 PLAY COIN NUMBER

```
*SET MENU *
V_x_ -----
Credit   Set
1 Credit 1 Coin
```

Default is **4** coins per play (Range : **1~10**).

5. BILL CREDIT SET-UP

```
*SET MENU *
V_x_ -----
Coin per Bill
1-Bill= 1 Coin
```

Default is **4** coins per bill (Range : **1~20** coin(s)).

6. COIN UP LIMIT

```
*SET MENU *
V_x_ -----
Credit Limit
Max Credit= 20
```

Maximum number of coin(s) up credits allowed.
Default coin up limit is **20** (Range : **1~ 100**).

7. PLAY TIME LIMIT

```
*SET MENU *
V_x_ -----
Time Limit
30 Sec
```

Default play time is **30** seconds
(Range : **10 ~ 60** sec).

8. DEMO SOUND

```
*SET MENU *
V_x_ -----
Demo Sound
On
```

Turn ON/OFF demo sound.
Default=**On**

9. EXAMPLE SETTING FOR PRIZELOADER ON GAME

```
*SET MENU *
V_x_ -----
Prize Show-off
      On
```

Setting Modes for moving Pusher Bar on forward/backward in front of the PrizeLoader of allocated hole when you stop the push bar on any hole location on game.

- PrizeLoader example forward mode On/Off Setting.
- Default=On (example function of moving forward a little and backward)

* Belowed 3 settings 10. attached GSM Module No setting 11. GSM Message DATA transmitting term setting 12. Receiver Phone No setting
Only applicabe when you attache the Communication Module which is Option item

10. ATTACHED GSM MODULE NO SETTING (APPLICABLE FOR ATTACHMENT WITH THE COMMUNICATION MODULE WHICH IS OPTION ITEM)

```
*SET MENU *
V_x_ -- 0000000000
GSM NO.
From : 0000000000
```

Input the USIM Number which is the No of communication GSM Module attached on Game Machine. GSM Module transfer Game Data, Erro Code, Prize out Data, Front Door of Game machine and Power On status to the Receiver instantly or on the time interval which is set up in previous.

- 1) Basic Value is 0000000000 and USIM Phone Number for Data transferring is not set up.
- 2) "[0000000000]" displays, when you push [SELECT] button and enter into Chagne Mode.
- 3) You can move to change location by {<}, {>}Button
{<} : Move Left , {>} : Move Right
- 4) After moving to the location you want to change, change the value by the {Up},{Dn}Button.
Setting Variation is 0~9, Blank.
{Up} : increase, {Dn} : decrease
- 5) Push [SELECT] Button after cahnging the Value.

11. SETTING THE TANSFER INTERVAL OF GSM MESSAGE DATA (APPLICABLE FOR ATTACHMENT WITH THE COMMUNICATION)

```
*SET MENU *
V_x_ -- 0000000000
Select Call Mode
      6 Hour
```

*** You can set up the transferring interval of game management data related to the profit, TODAY/TOTAL DATA and 6 Holes Data to the receiver.

- 1) Basic setting is 6 hours.
- 2) When you push [SELECT] Button, you enter to the mode of Probability change, "[6 hour]" displays.
- 3) After moving to the location you want to change, change the value by the {Up},{Dn}Button.
The Set up is Power On, 4, 6, 8, 12, 24 Hour.

Notice : No Data Transferring when Off is set.
{Up} : increase, {Dn} : decrease

- 4) Push [SELECT] Button after cahnging the Value.

12. SETTING RECEIVER'S PHONE NO (APPLICABLE FOR ATTACHEMENT WITH THE COMMUNICATION MODULE WHICH IS OPTION ITEM)

```
*SET MENU *
V__x_ -- 0000000000
Receiver Phone No.
To #1: 0000000000
```

*** Input the receiver's phone number which will receive game data, Error Code, Prize Out Data.

- 1) The Basic is 0000000000 and The phone No of Data Receiver is not set.
- 2) When you push [SELECT] Button, you enter to the mode of change, "[0000000000]" displays.
- 3) You can move to the change position by {<}, {>}Button.
{<} : Move Left , {>} : Move Right
- 4) After moving to the location you want to change, change the value by the {Up},{Dn}Button.
The Set up value is 0~9, blank
{Up} : increase, {Dn} : decrease
- 5) Push [SELECT] Button after changing the Value.
- 6) Recipients Phone NO. Setting, and up to **three**, {Up}, change the Phone {Dn} as Button.

13. SAVE & EXIT

```
*SET MENU *
V__x_ -----
Save & Cancel
Press [SEL] & [CLR]
```

Exit after saving set up by pushing [SELECT] Button.
Exit without saving when you long key [CLEAR] Button.

[GSM SENDING MESSAGE LIST]

	CONTENT	SMS (Short Message Service)	DESCRIPTION
1	Power On/Off	(Real-time Transport) (Power-On) (Power-Off)	Transmit Power On Transmit Power On(If the UPS is equipped with Option transfer function)
2	Front Door Status	(Real-time Transport) (Door-Close) (Door-Open)	On Door closed, power on, when they are closed or Door Transport When you open the Door Transport
3	Prize Out	(Real-time transmission at present emissions, Hole Data is also Transport) 1-HOLE PRIZE OUT 2-HOLE PRIZE OUT 3-HOLE PRIZE OUT 4-HOLE PRIZE OUT 5-HOLE PRIZE OUT 6-HOLE PRIZE OUT x-P:nnn T:nnnnn	1 HOLE Prize Out 2 HOLE Prize Out 3 HOLE Prize Out 4 HOLE Prize Out 5 HOLE Prize Out 6 HOLE Prize Out x: Hole number R: Probability settings C: Attempts (after prizes emissions) P: Prizes effluent T: Total number of attempts
4	Income data	(Such as 4 hours, 6 hours, 8 hours, 12 hours, 24 hours Income data according to the transmission time setting) TODAY=nnnnn/TOTAL=nnnnnn	TODAY :: After initialization income TOTAL :: Total income
5	Error report	(If an error occurs, real-time transmission) EE Pr : AC-Motor Error EE AC : AC-Motor Error EE S1 : AC-Motor Sensor 1 Error EE S2 : AC-Motor Sensor 1 Error EE F1 : Prize Motor Front Switch 1 Error EE F2 : Prize Motor Front Switch 2 Error EE F3 : Prize Motor Front Switch 3 Error EE F4 : Prize Motor Front Switch 4 Error EE F5 : Prize Motor Front Switch 5 Error EE F6 : Prize Motor Front Switch 6 Error EE rA : Prize Motor Rear Switch 1 Error EE rB : Prize Motor Rear Switch 2 Error EE r1 : Prize Motor Rear Switch 1 Error EE r2 : Prize Motor Rear Switch 2 Error EE r3 : Prize Motor Rear Switch 3 Error EE r4 : Prize Motor Rear Switch 4 Error EE r5 : Prize Motor Rear Switch 5 Error EE r6 : Prize Motor Rear Switch 6 Error EE 06 : Pusher Error EE 08 : Pusher Error EE 12 : Home Return Error EE 15 : Tilt Warning !!	Prize out Error AC-Motor Error (AC Sensor is open or closed when all) AC-Motor Sensor 1 (Open switch) Error AC-Motor Sensor 2 (Close switch) Error 1 HOLE Prize Motor Front Switch Error (Front of the switch failure) 2 HOLE Prize Motor Front Switch Error (Front of the switch failure) 3 HOLE Prize Motor Front Switch Error (Front of the switch failure) 4 HOLE Prize Motor Front Switch Error (Front of the switch failure) 5 HOLE Prize Motor Front Switch Error (Front of the switch failure) 6 HOLE Prize Motor Front Switch Error (Front of the switch failure) A HOLE Prize Motor Rear Switch Error (Front of the switch failure) B HOLE Prize Motor Rear Switch Error (Front of the switch failure) 1 HOLE Prize Motor Rear Switch Error (Front of the switch failure) 2 HOLE Prize Motor Rear Switch Error (Front of the switch failure) 3 HOLE Prize Motor Rear Switch Error (Front of the switch failure) 4 HOLE Prize Motor Rear Switch Error (Front of the switch failure) 5 HOLE Prize Motor Rear Switch Error (Front of the switch failure) 6 HOLE Prize Motor Rear Switch Error (Front of the switch failure) Pusher Rear SW. Error Pusher Front SW. Error Home Return Error Tilt Warning !!

5-4. Press and hold UP & DOWN buttons at the same time to enter "TEST MENU" .

1. CHECKING HOLE POSITION(S)

```
* TEST MENU *  
V__x_ -----  
Test All Rows  
Press CLEAR Button
```

*** Checking the Calibration hole place.
Press [CLEAR] button to calibrate all holes to check the hole positions.
"ts tn" appears Front panel FND, "n" stands for a hole number.
"do nE" appears when calibration completes.
If it failed, you should perform the Calibration due to the changed position.

2. Calibration

```
* TEST MENU *  
V__x_ -----  
Calibration  
0 (CLR=RESET)
```

*** Calibrating the hole position of Game machine, Only Calibration related data would be changed and saved.

If you push the [clear]Button, first, open and close the prize door on the lower part of Game machine 4 times.

```
* TEST MENU *  
V__x_ --000000000000  
PROGRESS...
```

The Calibration screen is as below, it shows the success times of each hole.

The meaning of this number is very important, 3~5 turns is basic value.

If it is lower or higher than that, it can affect the probability.

In case of this, you need to check 3~5 times by performing calibration after disassembling the screw of "S" letter on PusherBox and then fixing by pushing slightly the "S" letter on right or left side.

```
* TEST MENU *  
V__x_ -----  
Hole: 1 2 3 4 5 6  
CNT: 0 0 0 0 0 0
```

"Catn" displays on the front FND when you perform Calibration. "n" means the number of each hole. When it is done, "do ne" displays.

Exit to upper menu mode by pushing [SELECT] BUTTON.

3. Prize Motor Test

```
* TEST MENU *
V_x_ -----
Prize Motor
    ALL (CLR=PUSH)
```

*** Test the prize motor&switch on each prize cell.

- 1) Default is "ALL". If you press [CLEAR]Button all Prize Loader(6Ea) are tested at the same time.
If Front switch detect prize loader, it will stop automatically.
And press [CLEAR]Button to return Prize loader to starting point.

```
* TEST MENU *
V_x_ -----
Prize Motor
    ALL (CLR=PULL)
```

To return to the origin, again press the [CLEAR] Button is PrizeLoader 8 simultaneous retraction of motor and
When switching to Rear SW in PrizeLoader PrizeLoader 8ea all, you stop.
The test repeated each time you press the [CLEAR] Button.

- 2) If you want to select Prize loader, please enter select mode by pressing [SELECT]Button.
- 3) Using {<,>}Button Select Prize loader to test and press [CLEAR]Button to start testing.

4. Pusher Box Motor/Sensor Test

```
* TEST MENU *
V_x_ -----
Motor Test
Press SELECT Button
```

*** "Motor test" will test all functions and motor of Capsule hopper. It moves Pusher box right and left to test motors and sensors in Pusher Box. Once you press [SELECT] Button, you may see following screen and activate Test Mode.

Press the [SELECT] Button comes next screen, and activate the Test Mode, Prize Out Door is closed, and this means that the sensing point.

```
* TEST MENU *
V_x_ -----
-- S2 X0 RL -- --
Press CLEAR TO Exit
```

1) Front Door SW.Test

On the screen status, test the Main Door Open/Close SW in the Game machine. If the SW. is not pushed down (Door Open Status), "OP" displays. If the SW. is pushed down(Door Closed Status), "--" displays.

2) Prize out Door Test

If you press start button on the status like picture, prize outdoor will be open and display S1. And Press Start button again, Prize outdoor will be closed and display S2

S1 : Door Open SW, S2 : Door Close SW

3) Pusher Box Motor/Sensor Test

3-A) For Pusher box testing, button functions for moving pusher box are as following.

{<} : Right, {>} : Left / {Up} : Up, {Dn} : Down

3-B) Once a sensor perceives movement of pusher Box, relevant sensor will be displayed. Then next sensor is activated. Previous sensor will be shown as "--".

- Clt will display four items as following:

3-C) X0: Origin Sensor, RL:Rear Sensor, ML: Middle Sensor(Fail), FL: Front Sensor(Success)

```
* TEST MENU *
V_x_ -----
S1 S2 X0 RL ML FL
Press CLEAR TO Exit
```

4) If you press Clear button after finishing Motor/Sensor Test, it moves to [Motor Test]

5. Aging Test

```
* TEST MENU *
V__x_ -----
Aging Test
Press SELECT Button
```

*** Aging Test, depending on the game is set according to the probability of the normal routine, Each hole in order to try to game consoles, and Aging Test.

1) [SELECT] Button is pressed, the following screen will appear Aging Test To run.

```
* TEST MENU *
V__x_ -----
Entering Aging Test
```

2) Aging Test is repeated until the power is turned off.

3) Aging Test changes the value of ROW STATUS, you should initialize the value by performing "Initilaize Setup" after the test.

6. FACTORY INITIALIZE

```
* TEST MENU *
V__x_ -----
Factory Initialize
Press CLEAR Button
```

*** The Calibration as set all the settings to the factory default state.

If you press [CLEAR] Button, all setup come to factory setting and perform calibration. First of all, 4 times. open and close the Prize Door on the lower part of a machine.

```
* TEST MENU *
V__x_ -----
*Factory Initializing*
Wait a Moment...
```

The screen of calibration is as below picture.

It shows the number of success for each hole which should be stay between 3~5 because it's related with payout. Unless the number is between 3~5, It's strongly recommended to adjust "S" on Pusher Box.

```
* TEST MENU *
V__x_ -----
Hole: 1 2 3 4 5 6
CNT: 0 0 0 0 0 0
```

Is displayed as "Ca tn" in Calibration consoles run at the front of the FND. a number of holes, each "n" is Means. Once completed, you will see a "do nE".

If you press [SELECT] Button, it activates "Test All Rows" showing "ts tn" in FND. When it's finished you may see "do nE" in FND.

When it is done, the basic screen of Test Menu access displays.

7. INITIALIZING SET-UP VALUES

```
* TEST MENU *
V__x_ -----
Initialize Setup
Press CLEAR Button
```



*** Initialize all settings of "Set Menu" and some game data.
Press and hold [CLEAR] button to initialize the SET-UP values and data excluding calibration.
Calibration/Total is not affected.

8. SAVING THE TEST MENU AND EXIT

```
* TEST MENU *
V__x_ -----
Save & Cancel
Press [SEL] & [CLR]
```

Press the [SELECT] button to save the settings and exit the test menu.
press the [CLEAR] button to longkey without saving.

5-5. ERROR CODE

ERROR CODE	CONTENT	STATUS
1. EE-12	Home(Origin) Return Error - This Error code is generated in case of you cannot check the origin point due to origin point switch error or motors malfunction because the origin switch should be detected when you turn on the power or PusherBox returns back to origin point(Home) during the machine operation. Check and change the Origin switch or motor connected with PusherBox on back side of target Acryl inside of the machine.	ERROR EVENT, STOP
2. EE-AC	Prize Out Door Error - This Error code is generated in case of the prize door is closed when you turn on the power or the prize door is not working because the Prize door on the down side of the game should be opened and closed to dispense the prize when a game succeeds. Check and change the switch or motor connected with Prize Door.	ERROR EVENT, STOP
3. 	Prize Out Door Close S/W. Error - This Error code is generated in case of the prize door is not stopped at normal position or not working properly. In case of the prize door is closed when you turn on the power or when the game is success, prize door on the down side of machine should be closed after dispensing the prize.	ERROR EVENT, STOP
4. 	Prize Out Door Open S/W. Error - This Error code is generated in case of the prize door on the down side of the machine is not opening properly when you turn on the power or in case of game success because the prize door should be opened when Prize-Loader dispense the prize. Check and change the motor connected with Prize Door or the switch on open location (Rear SW.)	ERROR EVENT, STOP

5. EE-Ln	PrizeLoader Front S/W, Rear S/W Error n:Hole no. 1. If the initialization process, which checks Front SW of Prize Loader., And the Rear SW. Simultaneously when the power is turned on, 2. A check at the same time when the Front SW., And. Rear SW is in game mode or demo mode, which checks Error Code. 3. Inside that PrizeLoader Front SW., Check the Rear SW., Please replace.	ERROR EVENT, STOP
6. EE-Fn	PrizeLoader Front S/W or Motor Error n: Hole No. - This Error code is generated in case of a prize is not dispensed when a game succeeds and then the prize loader forwards in order to dispense the prize. Check and Change the motor on the back of PrizeLoader or the switch on Prizeloder(Front S,w)	ERROR EVENT, STOP
7. EE-rn	PrizeLoader Rear S/W or Motor Error n: Hole No. - This Error code is generated when you cannot check the origin point due to motor faulty or origin switch faulty because origin switch should be detected by returning back to origin point after the prizeloder dispenses a prize in case of game success or PrizeLoader is located at origin point when you turn on the power. Check and change the motor connected to the rear side of Prizeloder or the switch on origin point (Rear SW.)	ERROR EVENT, STOP
8. EE-06	Pusherbox Front/Back Moving Error, RARE SW ERROR - This Error code is generated in case of the bar of Pushbar succeeds but does not return back to Player direction after moving forward to the inner side. Check and Change the motor or the switch in the Pushbox.	ERROR EVENT, STOP
9. EE-08	Pusherbox Front/Back Moving Error, FRONT SW ERROR - This Error code is generated in case of the bar of pusher-box does not return back to Player side cause the bar should be at Player side after moving forward when you turn on the power or the machine is on operation. Check and Change the motor or the switch in the Push-box.	ERROR EVENT, STOP
10. EE-15	TILT Error - This Error code is generated in case of the machine is shaken or shocked. The machine will operate normally after performing the Error Event for 10 secs.	

6. HOW TO REPLACE MAJOR COMPONENTS

6-1) REPLACING MAIN PCB

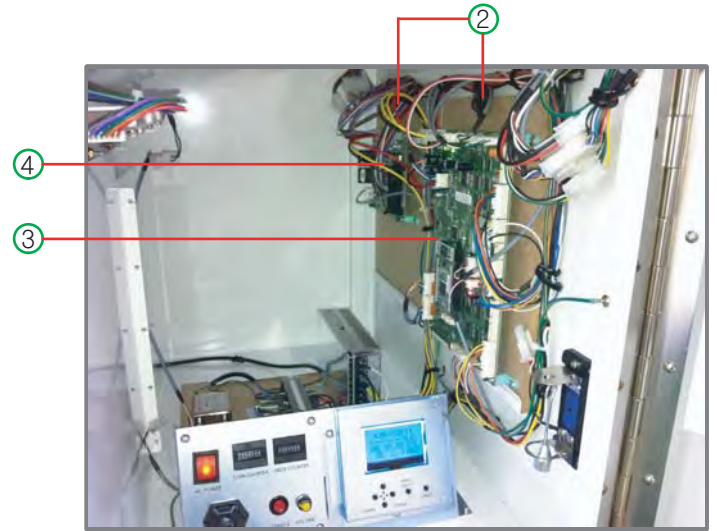
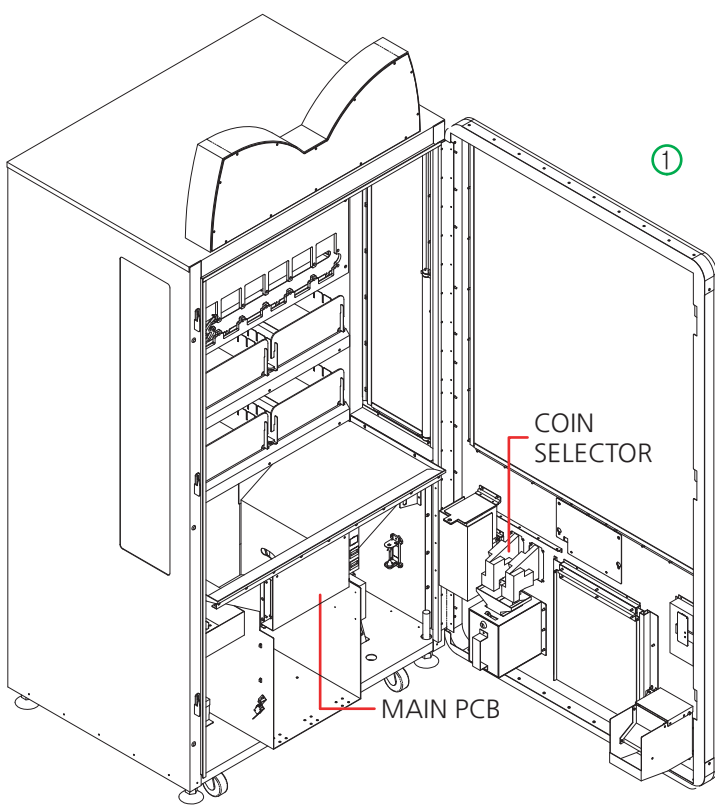

- (1) Open ① the front door.
- (2) ② Remove two bolts (size: M6).
- (3) Remove the connector between ③ Main PCB & ④ IO PCB, and then replace the Main PCB.
- (4) Re-assemble the parts in reverse order.

NO.	PART NAME	SPEC.	CODE NO.
③	MAIN PCB ASS'Y	-	AICU0PCB001
④	IO PCB ASS'Y	-	AICU0PCB002

6-2) REPLACING COIN SELECTOR

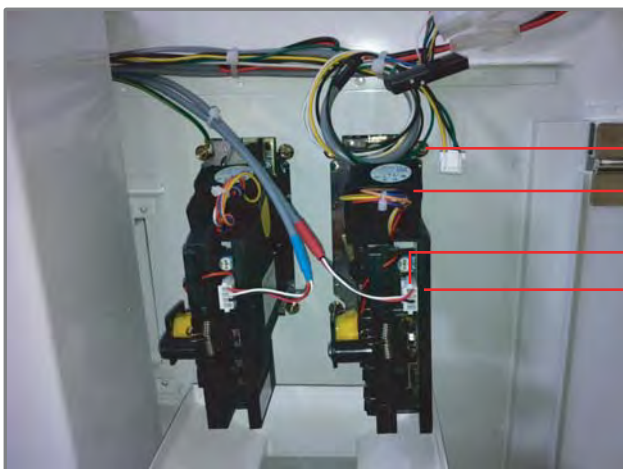

- (1) Open ① the front door.
- (2) ② Remove the connector.
- (3) ③ Remove eight bolts (size: M4) and nuts.
- (4) Remove the connector between ④ Main PCB & IO PCB, and then replace the Main PCB.
- (5) Re-assemble the parts in reverse order.

NO.	PART NAME	SPEC.	CODE NO.
⑤	COIN SELECTOR	TW-130B	MZZZCOSC032

* Reassemble them in reverse order and check performance of the game.

6-3) REPLACING PRIZE DISPENSER PART & Z MOVING PART

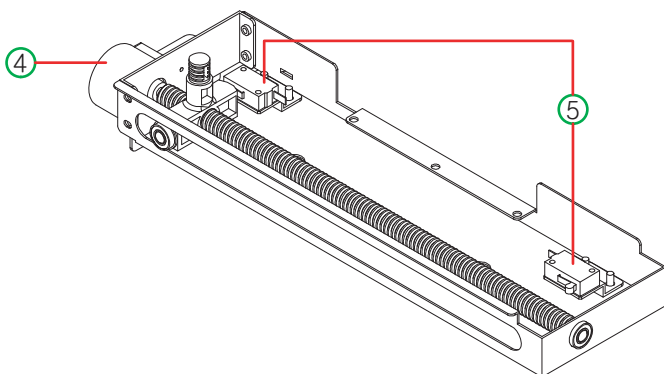
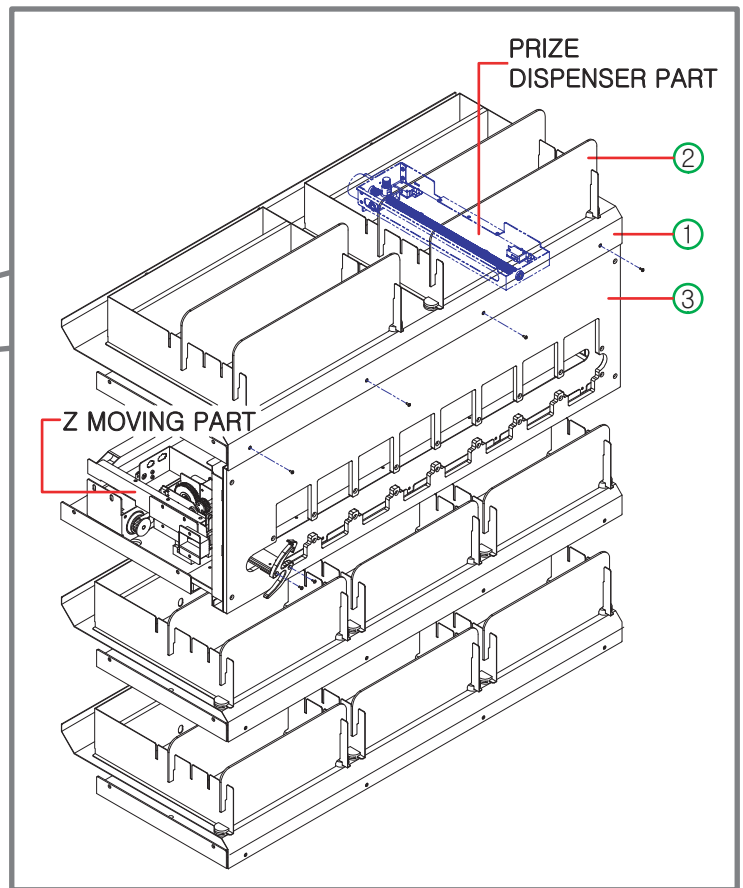
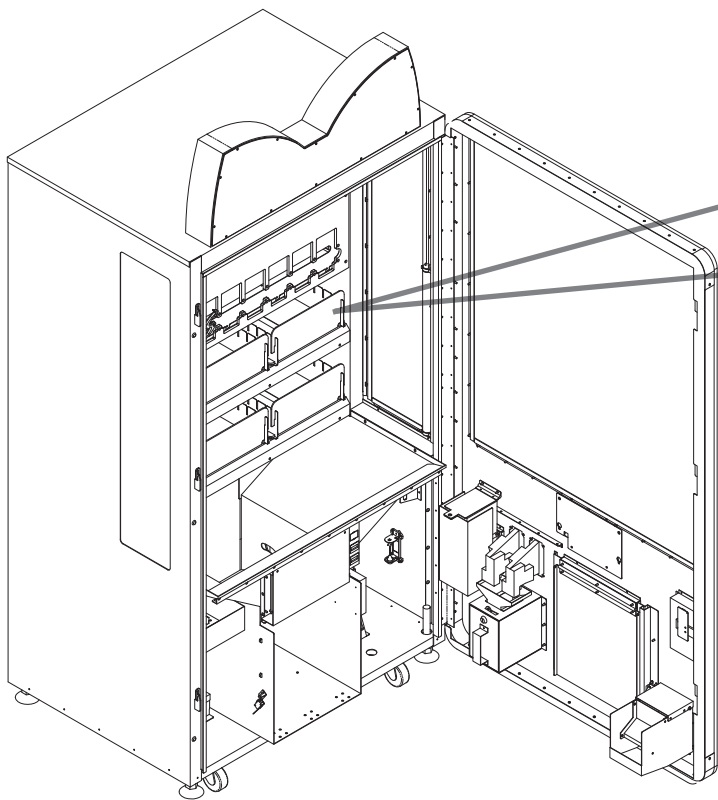

PRIZE DISPENSER PART

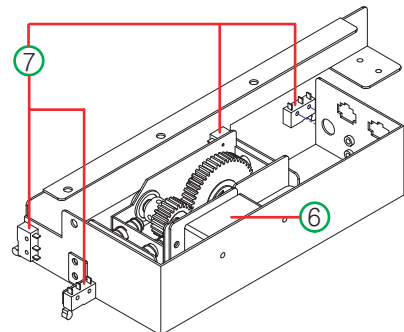

Z MOVING PART

- PRIZE DISPENSER PART

- (1) Remove the ① prize dispenser cover then remove the ② prize dispenser.
- (2) Locate the prize dispenser parts inside.
- (3) Remove connector, then replace ④ motor or ⑤ micro switch.

- Z MOVING PART

- (1) Remove ③ Target Display Part to locate Z-Moving part.
- (2) Remove the connector, then replace ⑥ motor or ⑦ Micro Switch.

NO.	PART NAME	SPEC.	CODE NO.
④	DC MOTOR	KWC_KD1-3429-095 (1:25)	MZZZ0MOT063
⑤	MICRO SWITCH	GSMV1651A2	MELE0MIC021
⑥	MOTOR	KWA-0255-IMF-04	MWIC0PAR025
⑦	MICRO SWITCH	SSM3142	MELE0MIC003

*** Reassemble them in reverse order and check performance of the game.**

7. TROUBLESHOOTING

7-1. IN CASE OF POWER FAILURE

*Common: Check the input voltage, check wiring

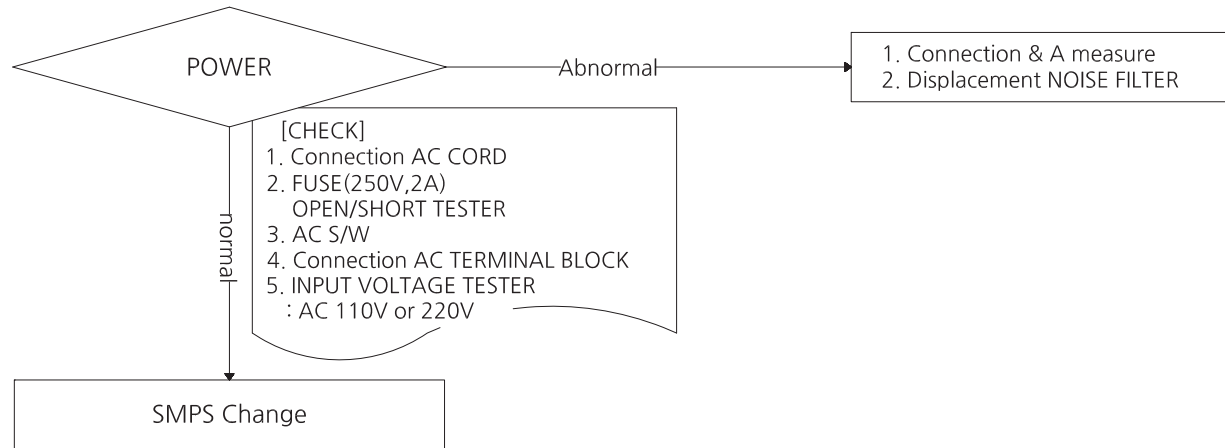

7-2. MOTOR ERROR

*Common: Check the input voltage, check wiring

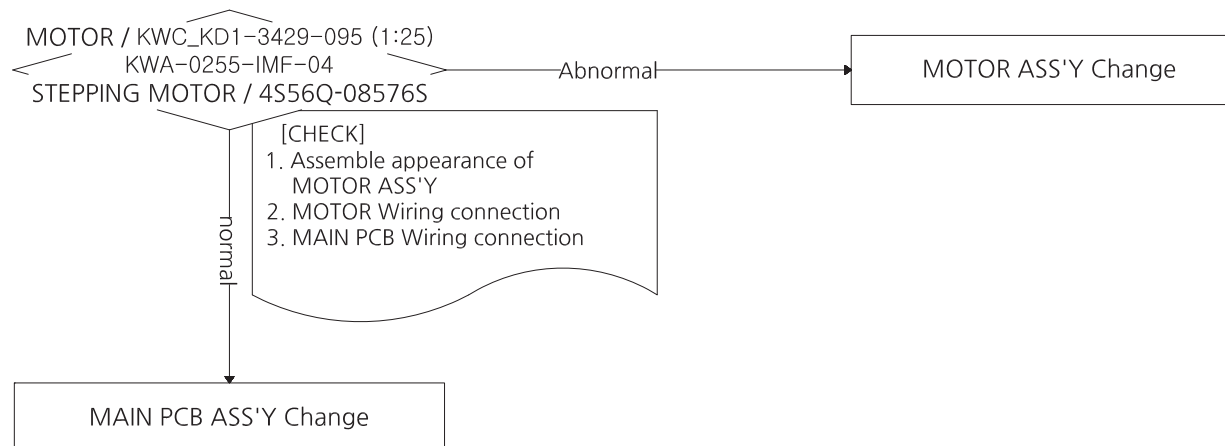

7-3. MICRO SWITCH ERROR

*Common: Check the input voltage, check wiring

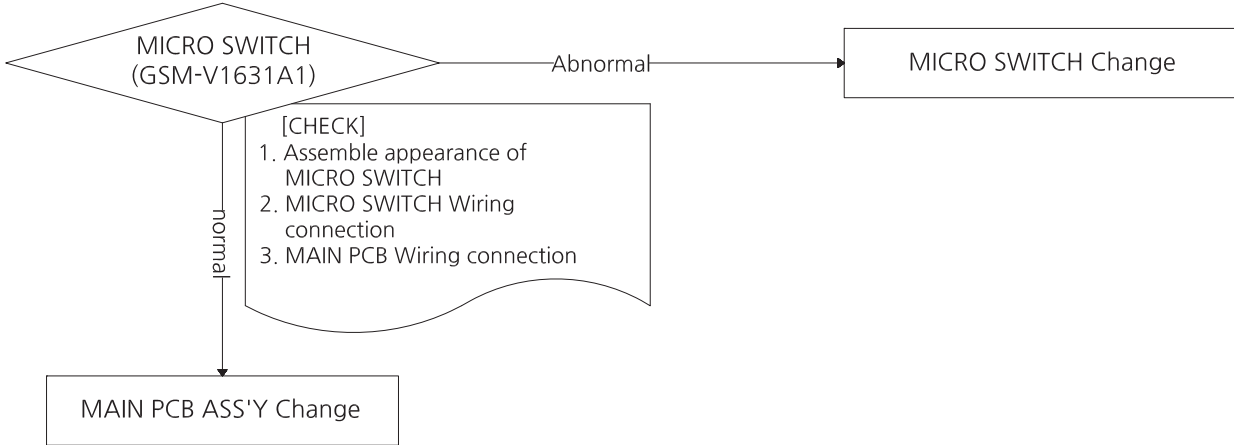

7-4. COIN SELECTOR ERROR

*Common: Check the input voltage, check wiring

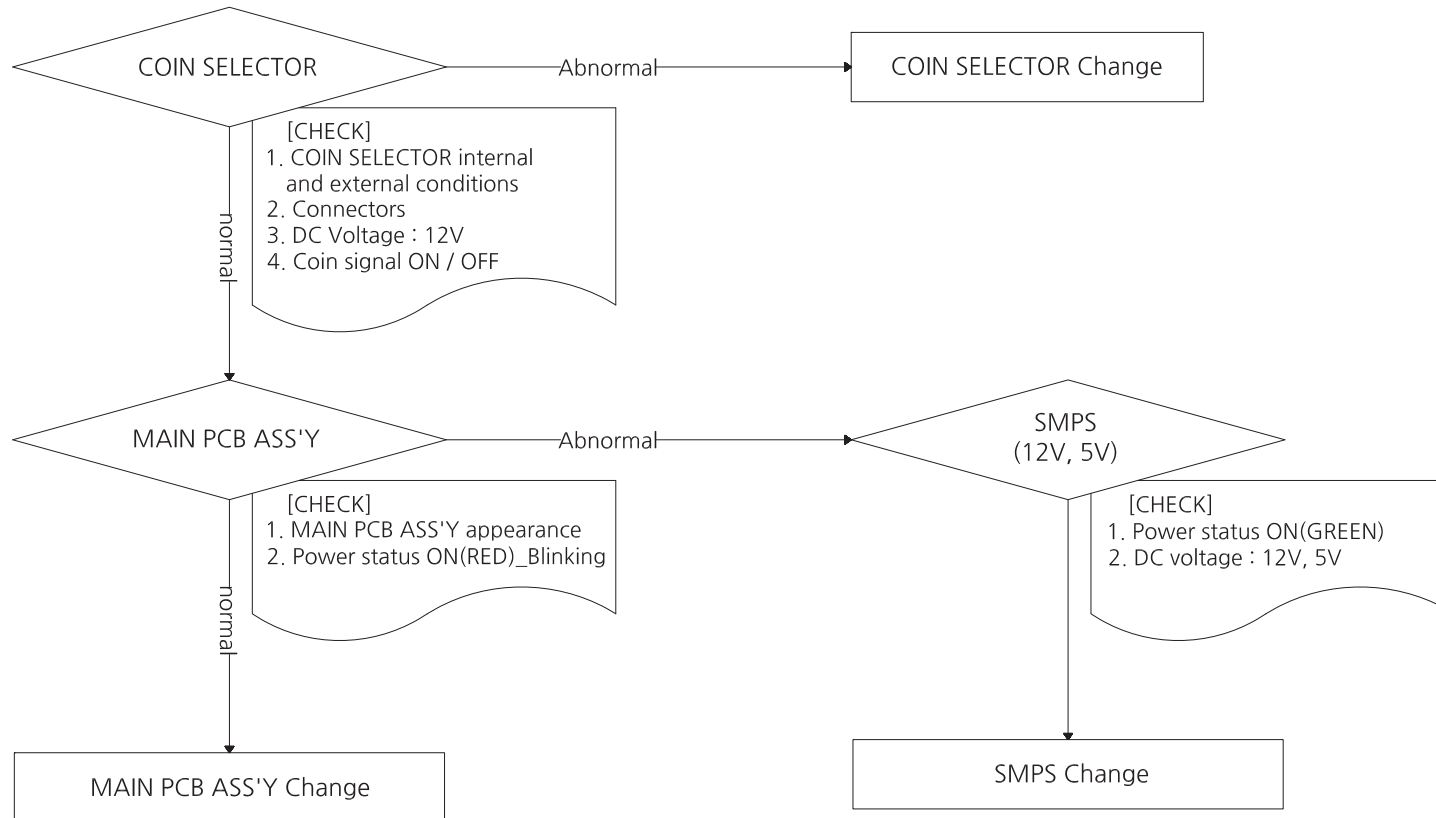

7-5. SOUND ERROR

*Common: Check the input voltage, check wiring

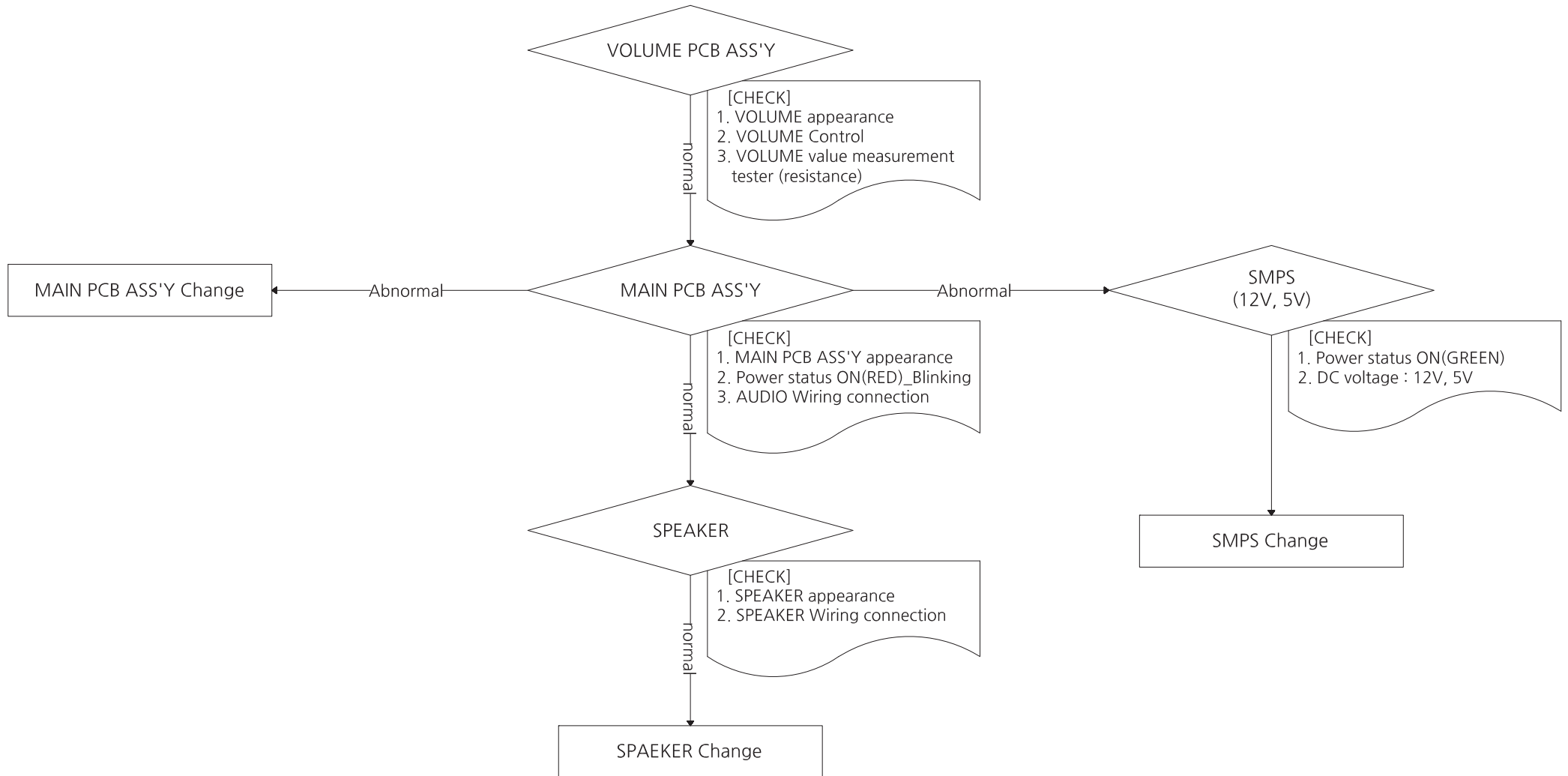

7-6. BUTTON & COUNTER ERROR

*Common: Check the input voltage, check wiring

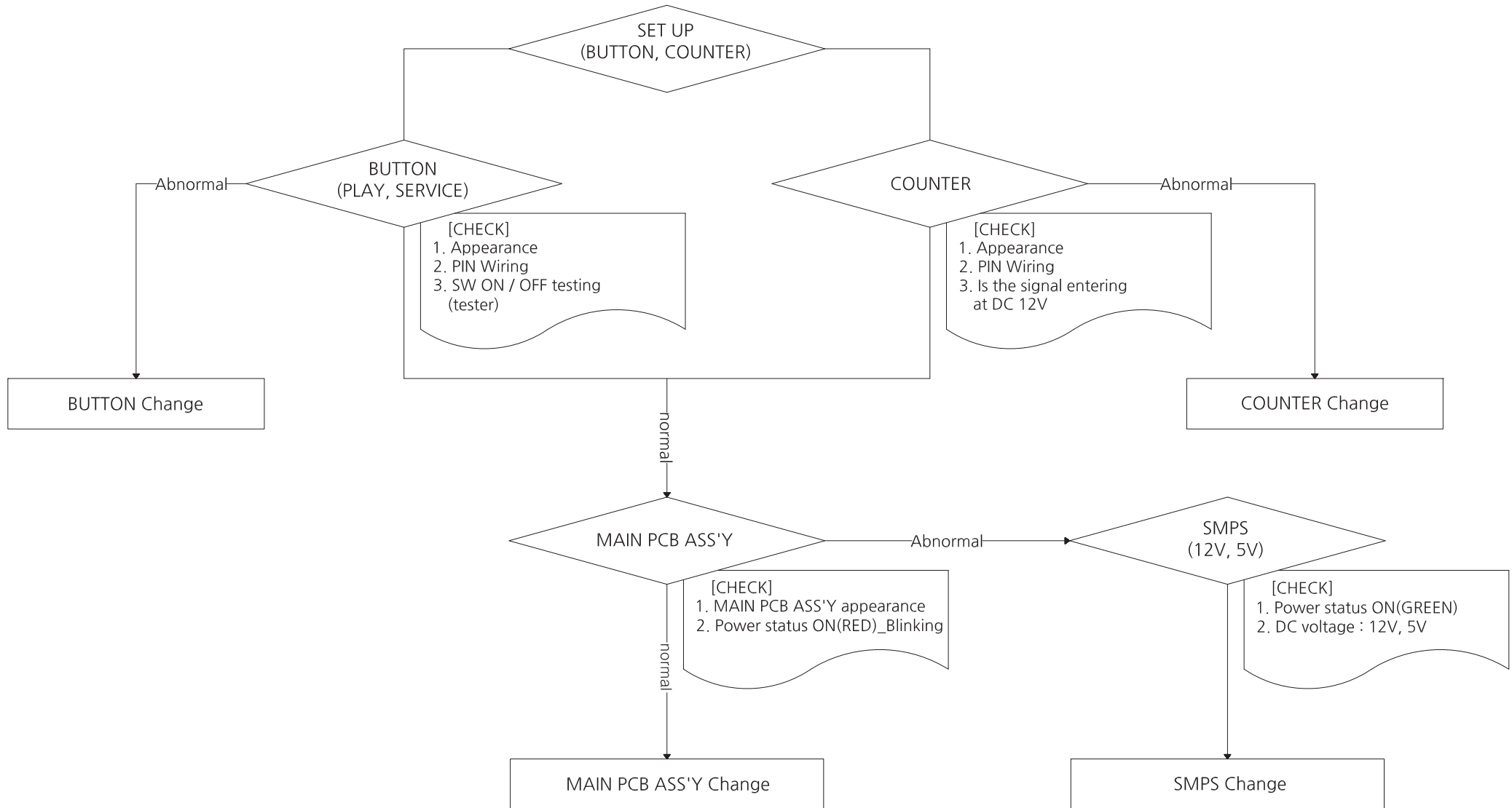

7-7. SETUP LCD PCB ERROR

*Common: Check the input voltage, check wiring

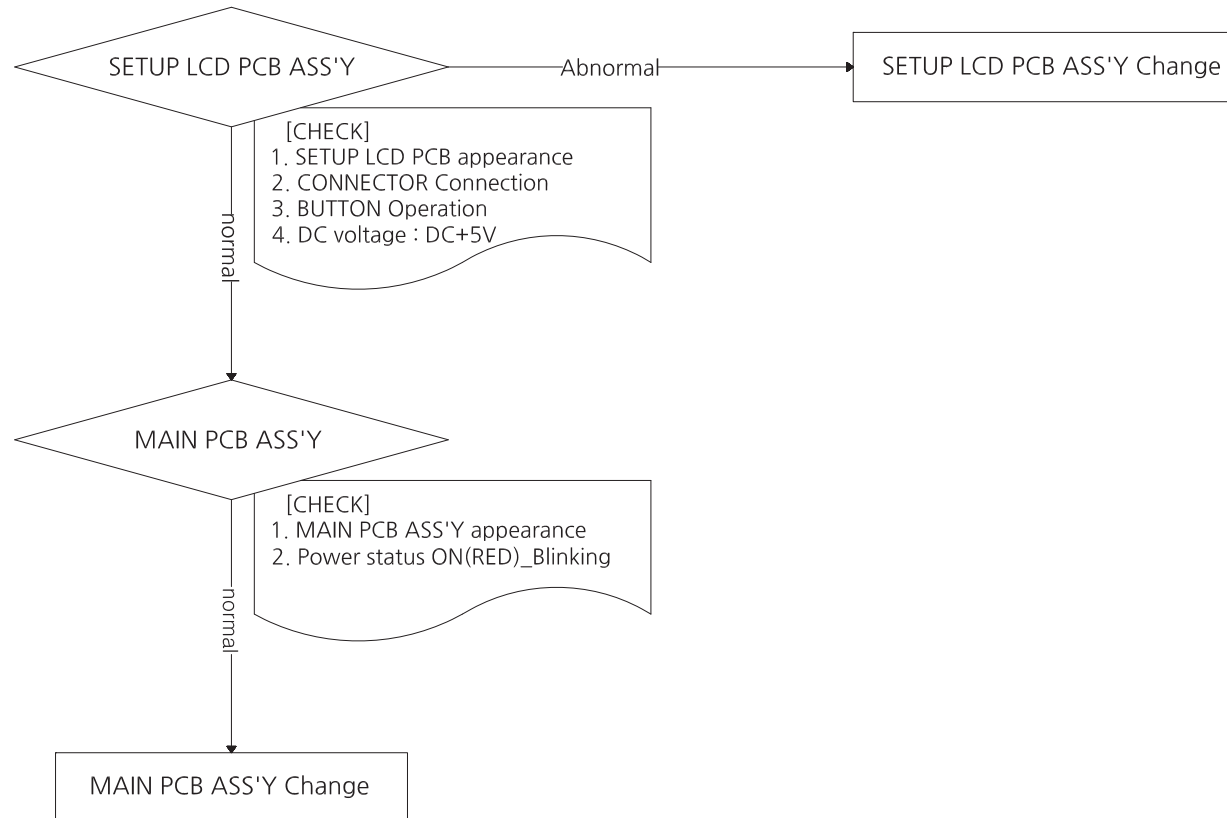

7-8. UPPER SIDE LIGHT PCB & CREDIT FND, TIME FND ERROR

*Common: Check the input voltage, check wiring

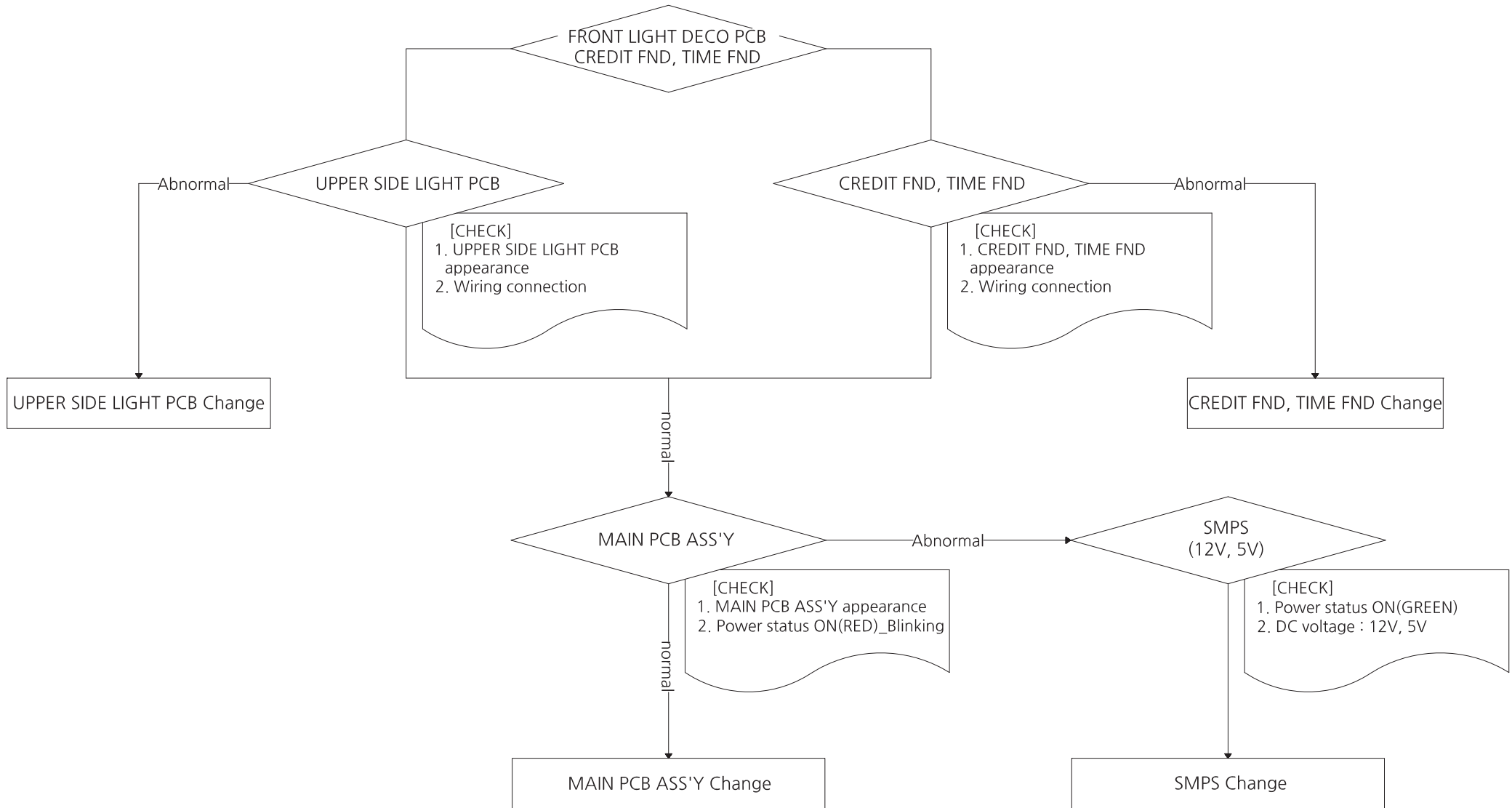

8. PARTS LIST

8-1. EXPLODED VIEW

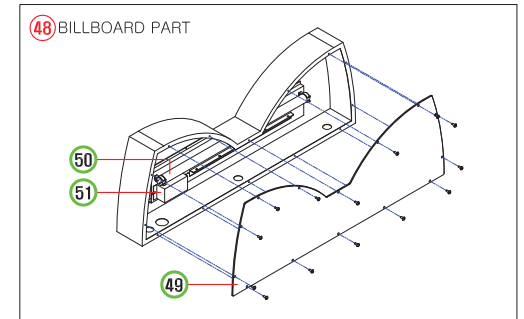
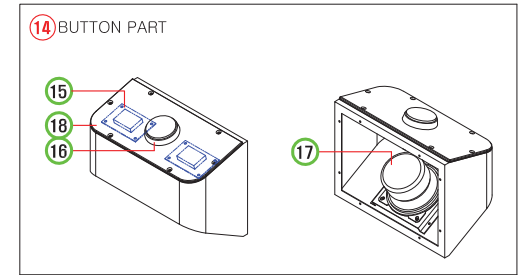
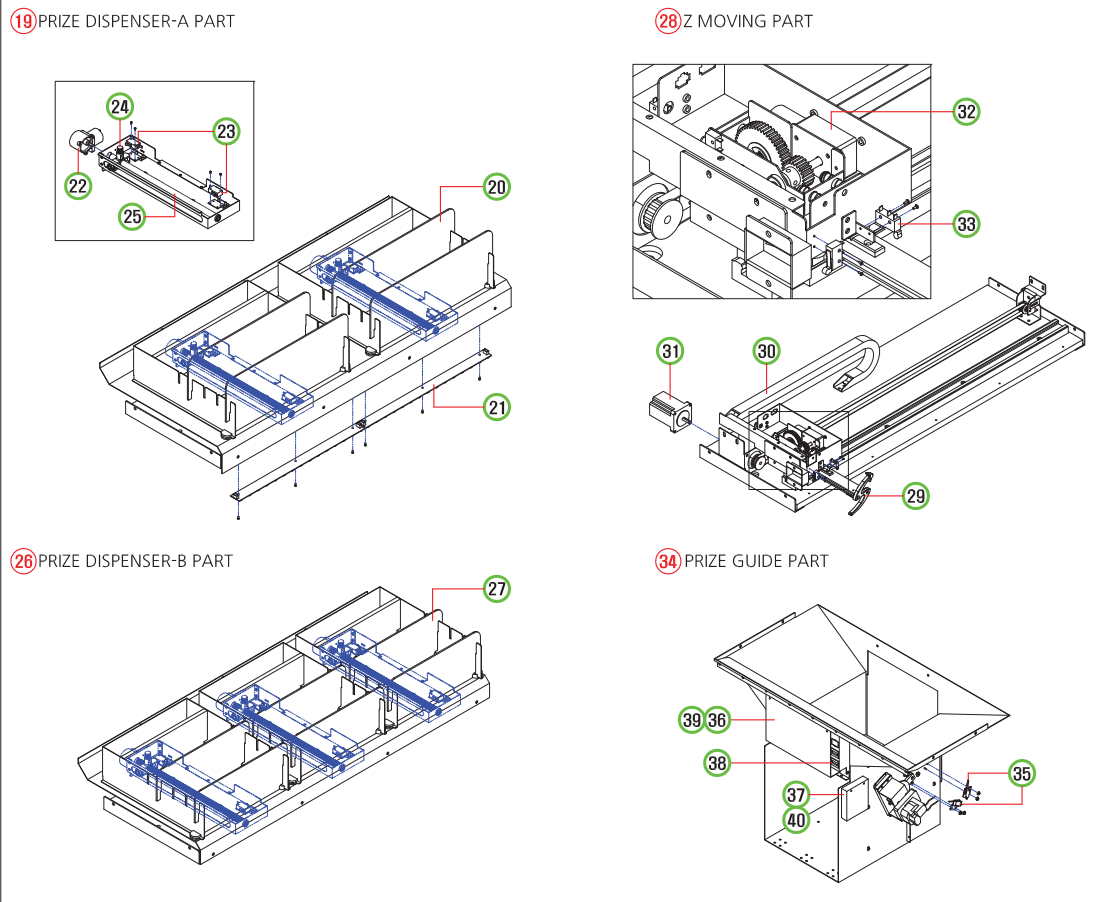

1 MAIN CABINET PART

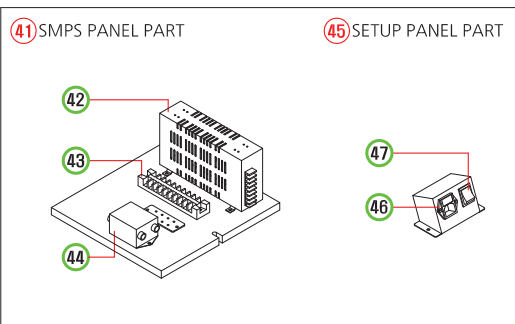
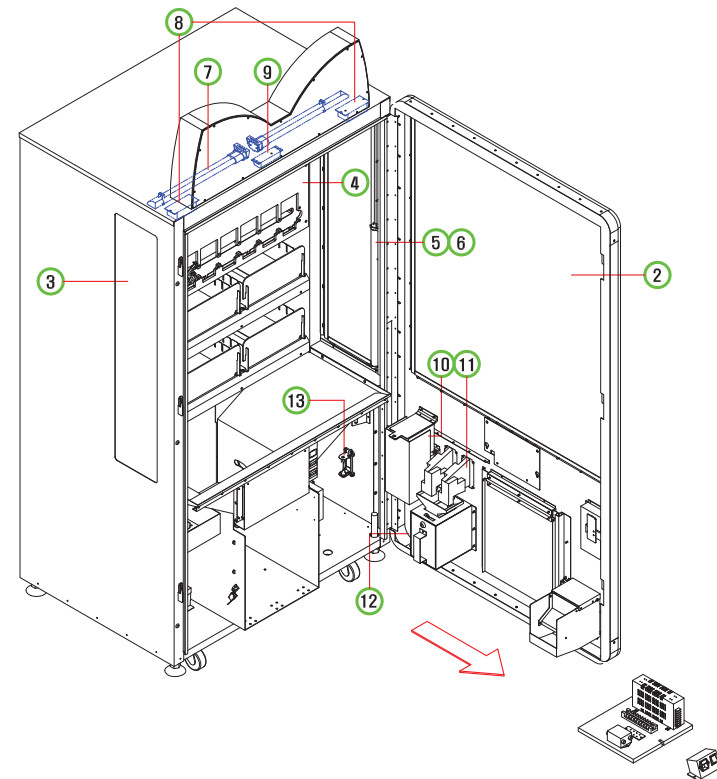

8-2. LIST

NO.	LEVEL	PART NAME	SPEC.	QTY	CODE NO.
①	1	MAIN CABINET PART			
②	2	FRONT DOOR GLASS	GLASS_8.0t	1	MICU0GLA002
③	2	SIDE GLASS	GLASS_8.0t	2	MICU0GLA001
④	2	TARGET DISPLAY ACRYL	ACRYL-8.0t	1	MICU0ACR002
⑤	2	FLUORESCENT LAMP	FL20SD-20W	2	MELE0LAM002
⑥	2	LAMP CLAMP	-	4	MELE0LAM014
⑦	2	LAMP	FPL 36W	2	MELE0LAM028
⑧	2	ELECTRONIC BALLAST	220V, 20W	2	MELE0BAL001
⑨	2	ELECTRONIC BALLAST	220V, FPL 36W_TWIN	1	MELE0BAL026
⑩	2	BILL ACCEPT	MEL_UP STACKER	1	-
⑪	2	COIN SELECTOR	TW-130B	2	MZZZ0COS032
⑫	2	KEY ASS'Y	6001	1	
⑬	2	TILT	-	1	MWICOPAR100
⑭	2	BUTTON FRAME PART			
⑮	2	FND PCB ASS'Y	-	2	AWID0PCB004
⑯	2	BUTTON SWITCH	AMIPB-60HR-W12D	1	MZZZ0BUT054
⑰	2	SPEAKER	MID4.5"+TW1/2" 8Ω	1	MZZZ0SPE021
⑱	2	BUTTON ACRYL	I CUBE	1	AICU0ACR001
⑲	2	PRIZE DISPENSER-A PART			
⑳	2	PRIZE DISPENSER PUSH ACRYL-B	ACRYL-3.0t	4	MICU0ACR005
㉑	2	FRONT LIGHT DECO PCB ASS'Y	-	2	APUT0PCB006
㉒	2	MOTOR	KWC_KD1-3429-095 (1:25)	8	MZZZ0MOT063
㉓	1	MICRO SWITCH	GSMV1651A2	16	MELE0MIC021
㉔	2	PRIZE DISPENSER BLOCK	ACETAL	8	MICU0PLA002
㉕	2	PRIZE DISPENSER SCREW	ABS	8	MICU0PLA001
㉖	2	PRIZE DISPENSER-B PART			
㉗	2	PRIZE DISPENSER PUSH ACRYL-A	ACRYL-3.0t	12	MICU0ACR004
㉘	2	Z MOVING PART			
㉙	2	PUSH DECO ACRYL	ACRYL-8.0t	1	MICU0ACR003
㉚	1	CABLE CHAIN	KJP018-1B-34LINK	1	MZZZ0CBC004
㉛	2	STEPPING MOTOR	4S56Q-08576S	1	MZZZ0MOT064
㉜	2	MOTOR	KWA-0255-IMF-04	1	MWICOPAR025
㉝	2	MICRO SWITCH	SSM3142	4	MELE0MIC003
㉞	1	PRIZE GUIDE PART			
㉟	2	MICRO SWITCH	GSM-V1631A1	2	MELE0MIC022

NO.	LEVEL	PART NAME	SPEC.	QTY	CODE NO.
⑳	2	MAIN PCB ASS'Y	-	1	AICU0PCB001
㉑	2	AC MOTOR IO PCB ASS'Y	-	1	AICU0PCB007
㉒	2	COUNTER	AMMC-712(OA127CL)	2	MZZZ0COU002
㉓	2	MAIN PCB PC COVER	PC-1.0	1	MICU0ACR023
㉔	2	AC MOTOR IO PC COVER	PC-1.0	1	MICU0ACR023
㉕	1	SMPS PANEL PART			
㉖	2	POWER SMPS	D-120A 12V, 5V	1	MELE0SMP045
㉗	2	TERMINAL BLOCK	250V, 10P		MELE0TEB003
㉘	2	NOISE FILTER	ES1-F10	1	MELE0NOI006
㉙	1	AC INPUT PART			
㉚	2	AC INPUT	DAC-13H	1	MELE0SWI005
㉛	2	ROCKER SWITCH	T-125 4P	1	MELE0SWI004
㉜	1	BILLBOARD PART			
㉝	2	BILLBOARD ACRYL	ACRYL-3.0t		MICU0ACR014
㉞	2	FLUORESCENT LAMP	FL20SD-20W	2	MELE0LAM002
㉟	2	ELECTRONIC BALLAST	220V, 20W	2	MELE0BAL001
Parts for 110V					
㊱	2	ELECTRONIC BALLAST	110V, 20W	2	MELE0BAL022
㊲	2	ELECTRONIC BALLAST	110V, FPL 36W_TWIN	1	MELE0BAL027

MAIN I/O 1/2

MARK	DATE	REVISION	DRAWN BY	CHECKED BY	APPROVED BY

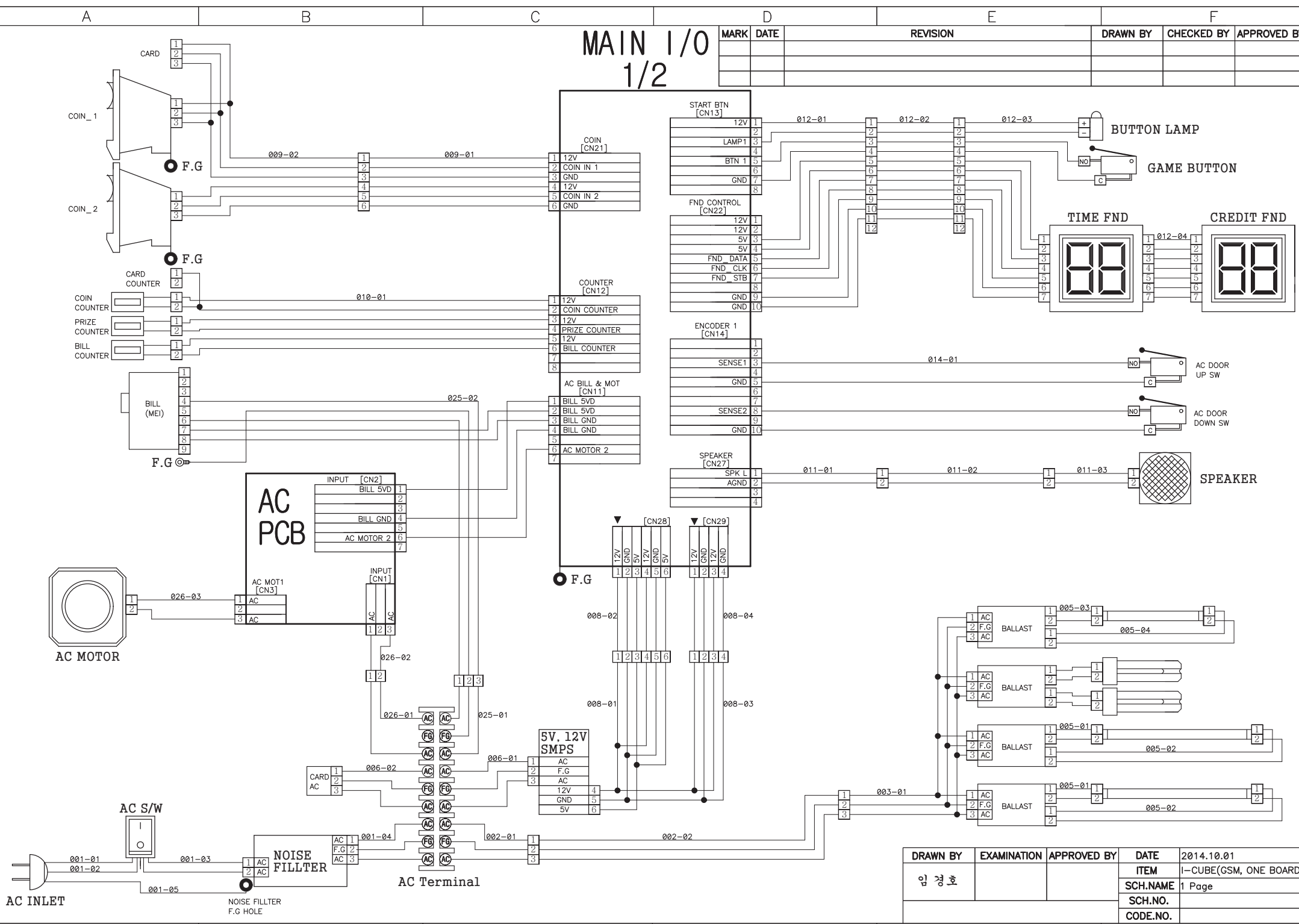

DRAWN BY	EXAMINATION	APPROVED BY	DATE	2014.10.01
임 경 호			ITEM	I-CUBE(GSM, ONE BOARD)
			SCH.NO.	1 Page
			SCH.NO.	
			CODE.NO.	

MAIN I/O 2/2

MARK	DATE	REVISION	DRAWN BY	CHECKED BY	APPROVED BY

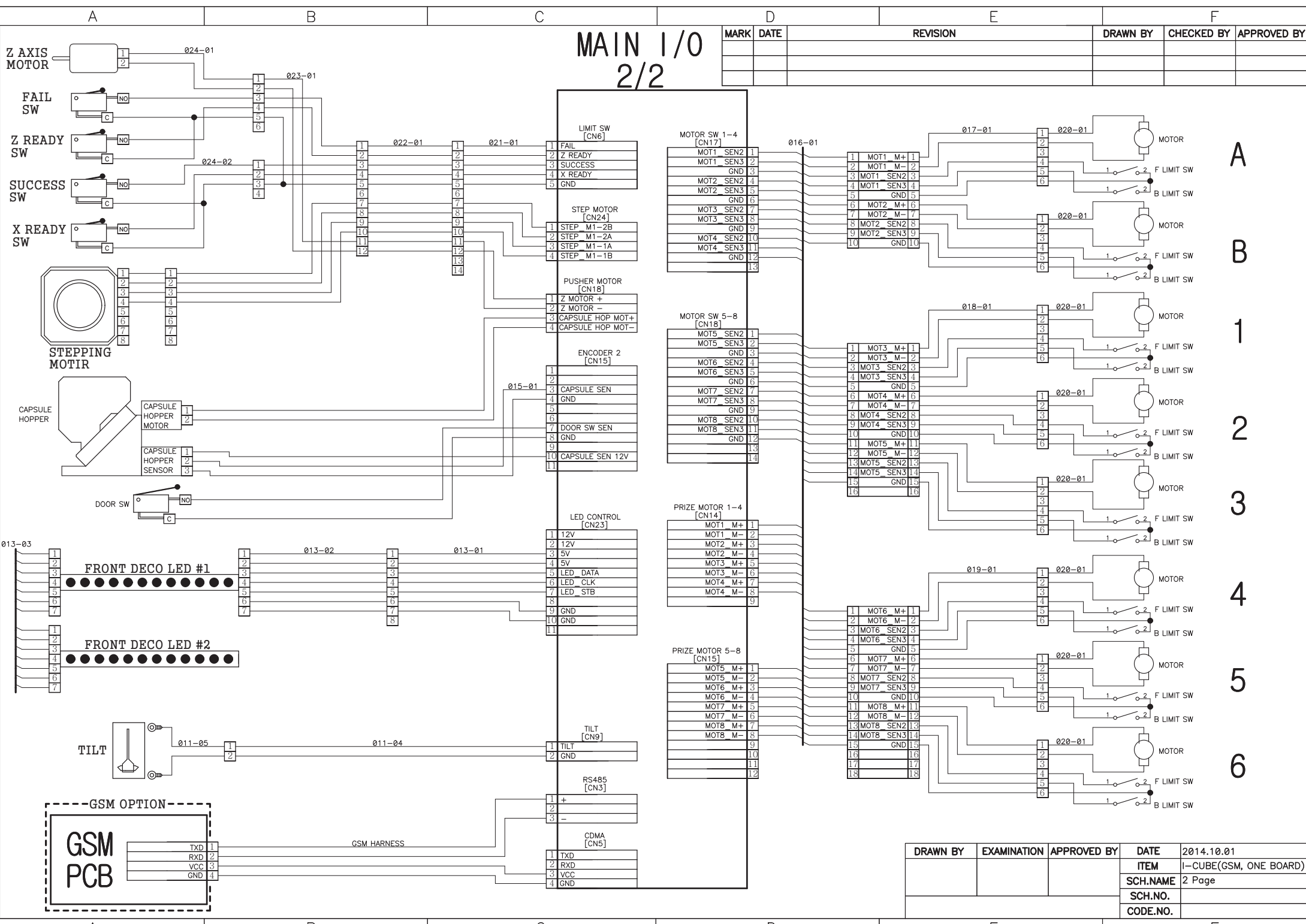

DRAWN BY	EXAMINATION	APPROVED BY	DATE	2014.10.01
				ITEM
				I-CUBE(GSM, ONE BOARD)
				SCH.NO
				2 Page
				SCH.NO.
				CODE.NO.